

PCB mounting

Flux-p roof terminals

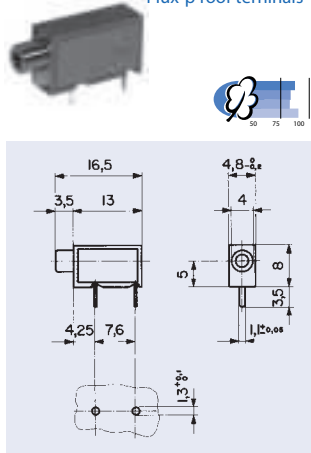

Contact system

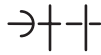

Rated current

6,3 A

Contact resistance at 20 mV

<10 mΩ

Insulation resistance, 1 min. contact to contact

> 10⁴ MΩ

Contact/mounting plate

> 10⁴ MΩ

Dielectric strength, 50 Hz, 1 min. contact to contact

> 2 kV

Contact/mounting plate

> 2 kV

Temperature at no current

-25 °C up to +100 °C

at rated current

-25 °C up to +70 °C

Solderability

2 sec., 235 °C IEC 68-2-20 test Ta, test method 1

Resistance to soldering heat

5 sec., 260 °C IEC 68-2-20 test Tb, test method 1 A

Surface of contacts (average thickness)

2,5 μm Au

Tin-plated contacts on request

Type

PBD

Order No.

0040.1211 | black

Color

0040.1212 | red