



L8020

Preliminary

LINEAR INTEGRATED CIRCUIT

DUAL POLARISATION SWITCH TWIN LNB MULTIPLEX CONTROLLER

DESCRIPTION

The UTC **L8020** dual polarisation switch controller is one of a wide range of satellite receiver LNB support circuits. Its features include completely independent channels, and every channel provides two logic outputs under the voltage sensitive input. The two inputs of the UTC **L8020** have a nominal threshold of 14.5V. Their threshold is temperature compensated to minimize drift. In order to achieve the transient protection by adding only a single resistor per channel, each input has a low and stable input current.

Normal and inverted outputs are provided for each input. All outputs can source 15mA and sink 10mA making them suitable to drive TTL and CMOS logic, pin diodes and for IF-amp supply switching.

The UTC **L8020** works in a single supply ranging from 5V to 12V. The quiescent current of the UTC **L8020** is 4mA, and there is no remarkable change with load or logic state. In order to adapt the variation of environmental conditions, the ambient operating temperature is -40°C~+85°C.

The UTC **L8020** can be used in applications, such as IF switch box, LNB switch boxes and twin LNBS, replacing many discrete components to save both manufacturing cost and PCB size as well as improving reliability.

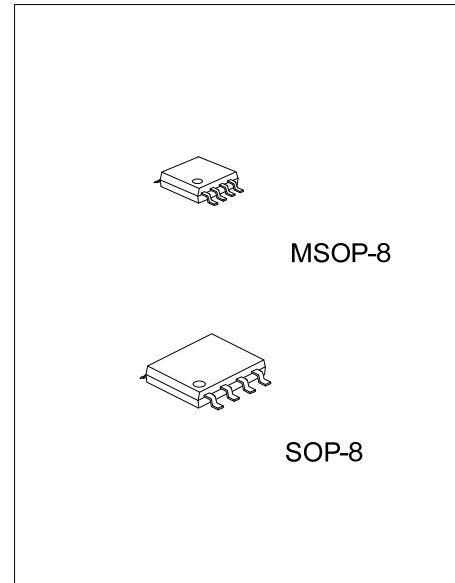

FEATURES

- * Avoid external components
- * Provides polarity detection and control
- * Transient resistant
- * Low input and supply current
- * Temperature compensated input threshold
- * Normal and inverted output available while wide supply operating range
- * Dual polarisation switch
- * Simplify the design

ORDERING INFORMATION

| Ordering Number | | Package | Packing |
|-----------------|--------------|---------|-----------|
| Lead Free | Halogen Free | | |
| L8020L-S08-R | L8020G-S08-R | SOP-8 | Tape Reel |
| L8020L-S08-T | L8020G-S08-T | SOP-8 | Tube |
| L8020L-SM1-R | L8020G-SM1-R | MSOP-8 | Tape Reel |
| L8020L-SM1-T | L8020G-SM1-T | MSOP-8 | Tube |

| | |
|--|--|
| <p>L8020L-S08-R</p> <p>(1) Packing Type (2) Package Type (3) Lead Free</p> | <p>(1) R: Tape Reel, T: Tube (2) S08: SOP-8, SM1: MSOP-8 (3) G: Halogen Free, L: Lead Free</p> |
|--|--|

■ PIN CONFIGURATION

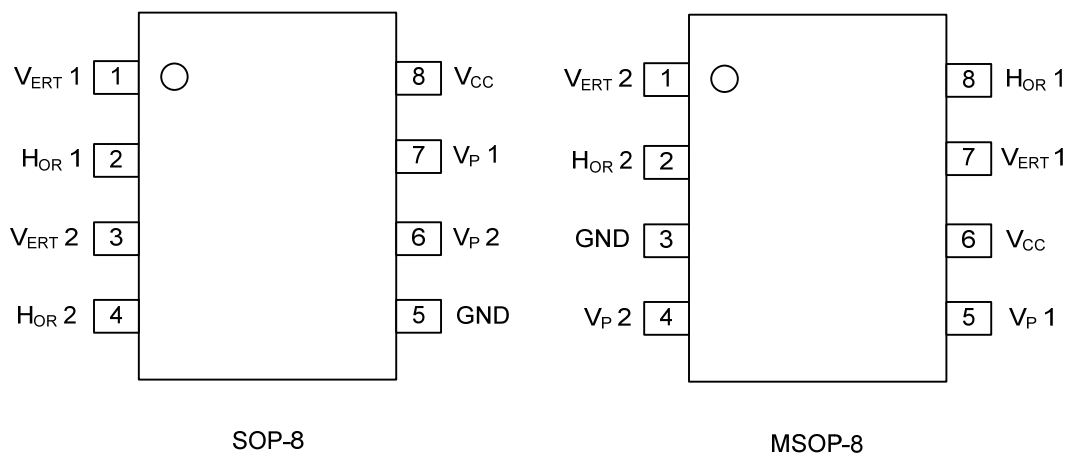

■ PIN DESCRIPTION

| PIN NO. | | PIN NAME | DESCRIPTION |
|---------|--------|--------------------|-------------------------|
| SOP-8 | MSOP-8 | | |
| 1 | 7 | V _{ERT} 1 | Vertical output 1 |
| 2 | 8 | H _{OR} 1 | Horizontal output 1 |
| 3 | 1 | V _{ERT} 2 | Vertical output 2 |
| 4 | 2 | H _{OR} 2 | Horizontal output 2 |
| 5 | 3 | GND | Ground connection pin. |
| 6 | 4 | V _P 2 | Polarity select input 2 |
| 7 | 5 | V _P 1 | Polarity select input 1 |
| 8 | 6 | V _{CC} | Supply voltage |

■ ABSOLUTE MAXIMUM RATING

| PARAMETER | SYMBOL | RATINGS | UNIT |
|--|-----------|----------|------------------|
| Supply Voltage | V_{CC} | -0.6~+15 | V |
| Input Voltage (V_{POL1} and V_{POL2}) | V_{IN} | 25 | V |
| Supply Current | I_{CC} | 50 | mA |
| Power Dissipation ($T_A=25^\circ\text{C}$) | MSOP-8 | 400 | mW |
| | SOP-8 | 500 | |
| Operating Temperature | T_{OPR} | -40~+85 | $^\circ\text{C}$ |
| Storage Temperature | T_{STG} | -40~+85 | $^\circ\text{C}$ |

Note: Absolute maximum ratings are those values beyond which the device could be permanently damaged. Absolute maximum ratings are stress ratings only and functional device operation is not implied.

■ ELECTRICAL CHARACTERISTICS

($T_A=25^\circ\text{C}$, $V_{CC}=5\text{V}$, $I_D=10\text{mA}$ ($R_{CAL1}=33\text{k}\Omega$), unless otherwise specified)

| PARAMETER | SYMBOL | TEST CONDITIONS | MIN | TYP | MAX | UNIT |
|---|------------|---|--------------|--------------|----------|---------------|
| Supply Voltage | V_{CC} | | 5 | | 12 | V |
| Supply Current | I_{CC} | All inputs and outputs open circuit | | | 10 | mA |
| | | $I_{VERT1}=I_{VERT2}=10\text{mA}$, $V_{POL1}=V_{POL2}=14\text{V}$ | | | 30 | mA |
| | | $I_{HOR1}=I_{HOR2}=10\text{mA}$, $V_{POL1}=V_{POL2}=15.0\text{V}$ | | | 30 | mA |
| V_{POL1} and V_{POL2} Inputs | | | | | | |
| Current | I_{POL} | $V_{POL1}=V_{POL2}=25\text{V}$ (Note 1) | 10 | 20 | 40 | μA |
| Threshold Voltage | V_{TPOL} | (Note 1) (Note 2) | 14.0 | 14.5 | 15.0 | |
| Switching Speed | T_{SPOL} | | | | 100 | μs |
| V_{VERT} 1/2 Outputs | | | | | | |
| Voltage High | V_{VH} | $I_{VERT1}=I_{VERT2}=10\text{mA}$, $V_{POL1}=V_{POL2}=14\text{V}$ | $V_{CC}-1.0$ | $V_{CC}-0.8$ | V_{CC} | V |
| | | $I_{VERT1}=I_{VERT2}=15\text{mA}$, $V_{POL1}=V_{POL2}=14\text{V}$ | $V_{CC}-1.2$ | $V_{CC}-0.9$ | V_{CC} | V |
| | | $I_{VERT1}=I_{VERT2}=10\mu\text{A}$, $V_{POL1}=V_{POL2}=14\text{V}$ | $V_{CC}-0.2$ | $V_{CC}-0.1$ | V_{CC} | V |
| Voltage Low | V_{VL} | $I_{VERT1}=I_{VERT2}=-10\text{mA}$, $V_{POL1}=V_{POL2}=15.0\text{V}$ | 0 | 0.25 | 0.5 | V |
| I_{HOR} 1/2 Outputs | | | | | | |
| Voltage High | V_{VH} | $I_{HOR1}=I_{HOR2}=10\text{mA}$, $V_{POL1}=V_{POL2}=15.0\text{V}$ | $V_{CC}-1.0$ | $V_{CC}-0.8$ | V_{CC} | V |
| | | $I_{HOR1}=I_{HOR2}=15\text{mA}$, $V_{POL1}=V_{POL2}=15.0\text{V}$ | $V_{CC}-1.2$ | $V_{CC}-0.9$ | V_{CC} | V |
| | | $I_{HOR1}=I_{HOR2}=10\mu\text{A}$, $V_{POL1}=V_{POL2}=15.0\text{V}$ | $V_{CC}-0.2$ | $V_{CC}-0.1$ | V_{CC} | V |
| Voltage Low | V_{VLOW} | $I_{HOR1}=I_{HOR2}=-10\text{mA}$, $V_{POL1}=V_{POL2}=14\text{V}$ | 0 | 0.25 | 0.5 | V |

Notes: 1. V_{POL1} and V_{POL2} switching thresholds apply over the whole operating temperature range specified above.
2. Applied via 10k resistors

■ TYPICAL APPLICATION CIRCUIT

A twin LNB design is as followed. In this block diagram, the UTC **L8020** provides the two polarity switches required to decode the two independent receiver feeds.

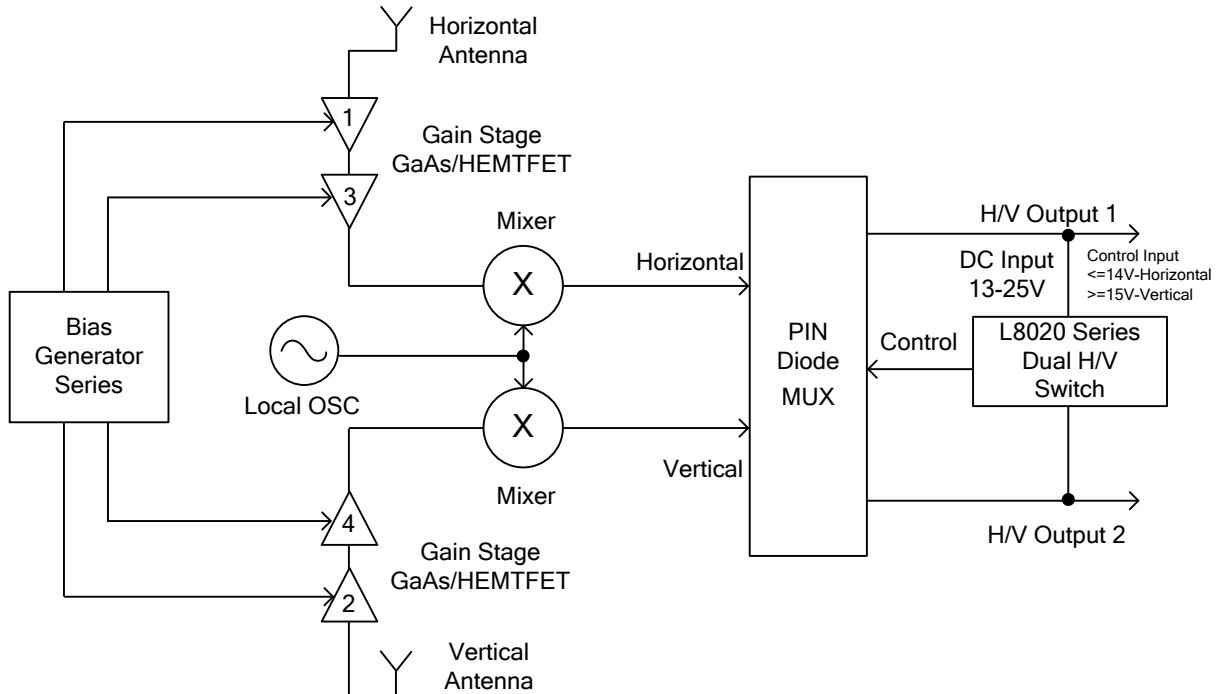

UTC assumes no responsibility for equipment failures that result from using products at values that exceed, even momentarily, rated values (such as maximum ratings, operating condition ranges, or other parameters) listed in products specifications of any and all UTC products described or contained herein. UTC products are not designed for use in life support appliances, devices or systems where malfunction of these products can be reasonably expected to result in personal injury. Reproduction in whole or in part is prohibited without the prior written consent of the copyright owner. The information presented in this document does not form part of any quotation or contract, is believed to be accurate and reliable and may be changed without notice.