

FEATURES

- 3.3V and 5V power supply option
- Differential D, CLK and Q
- Extended V_{EE} range of $-3.0V$ to $-5.5V$
- V_{BB} output for single-ended use
- 1100MHz min. toggle frequency
- Asynchronous Reset and Set
- Fully compatible with Motorola MC100LVEL29 and MC100EL29
- Available in 20-pin SOIC package

PIN CONFIGURATION/BLOCK DIAGRAM

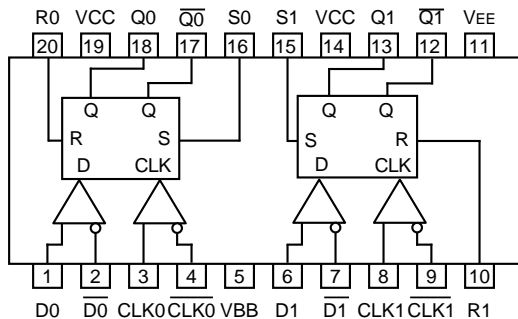

**SOIC
TOP VIEW**

DESCRIPTION

The SY100EL29V is a dual differential register with differential data (inputs and outputs) and clock. The registers are triggered by a positive transition of the positive clock (CLK) input. A HIGH on the Reset (R_x) asynchronously resets the appropriate register so that the Q outputs go LOW. A HIGH on the Set (S_x) asynchronously sets the appropriate register so that the Q outputs go HIGH. The Set and Reset inputs cannot both be HIGH simultaneously.

The differential input structures are clamped so that the inputs of unused registers can be left open without upsetting the bias network of the devices. The clamping action will assert the $/D$ and the $/CLK$ sides of the inputs. The noninverting input will pull down to V_{EE} and the inverting input will be biased around $V_{CC}/2$. Because of the edge-triggered flip-flop nature of the devices, simultaneously opening both the clock and data inputs will result in an output which reaches an unidentified but valid state.

The fully differential design of the devices makes them ideal for very high frequency applications where a registered data path is necessary.

PIN NAMES

Pin	Function
CLK, $/CLK$	Differential Clock Inputs
$D[0:1]$, $/D[0:1]$	Differential Data Inputs
$Q[0:1]$, $/Q[0:1]$	Differential Data Outputs
R_0 , R_1	Reset Inputs
S_0 , S_1	Set Inputs
V_{BB}	V_{BB} Reference Output
V_{CC}	V_{CC}
V_{EE}	V_{EE}

TRUTH TABLE

R	S	D	CLK	Q	$/Q$
L	L	L	Z	L	H
L	L	H	Z	H	L
H	L	X	X	L	H
L	H	X	X	H	L
H	H	X	X	Undef	Undef

NOTE:
Z = LOW-to-HIGH Transition

ABSOLUTE MAXIMUM RATINGS⁽¹⁾

Symbol	Rating	Value	Unit
V_{EE}	Power Supply ($V_{CC} = 0V$)	-8.0 to 0	VDC
$V_I^{(3)}$	Input Voltage ($V_{CC} = 0V$)	0 to -6.0	VDC
I_{OUT}	Output Current -Continuous -Surge	50 100	mA
T_A	Operating Temperature Range	-40 to +85	°C
V_{EE}	Operating Range ^{(1),(2)}	-5.7 to -3.0	V

NOTES:

1. Absolute maximum rating, beyond which, device life may be impaired, unless otherwise specified on an individual data sheet.
2. Parametric values specified at: 100EL29V Series: -3.0V to -5.5V.
3. In PECL mode operation, $V_I(\text{Max}) = V_{CC}$.

DC ELECTRICAL CHARACTERISTICS
 $V_{EE} = -3.0V$ to $+5.5V$; $V_{CC} = \text{GND}$

Symbol	Parameter	$T_A = -40^\circ\text{C}$		$T_A = 0^\circ\text{C}$		$T_A = +25^\circ\text{C}$			$T_A = +85^\circ\text{C}$		Unit
		Min.	Max.	Min.	Max.	Min.	Typ.	Max.	Min.	Max.	
I_{EE}	Power Supply Current	—	50	—	50	—	30	50	—	50	mA
I_{IH}	Input HIGH Current	—	150	—	150	—	—	150	—	150	μA
I_{IL}	Input LOW Current /CLK, /Dn	0.5 -300	— —	0.5 -300	— —	0.5 -300	— —	— —	0.5 -300	— —	μA
V_{BB}	Output Reference Voltage	-1.38	-1.26	-1.38	-1.26	-1.38	—	-1.26	-1.38	-1.26	V

AC ELECTRICAL CHARACTERISTICS $V_{EE} = -3.0V$ to $+5.5V$; $V_{CC} = GND$

Symbol	Parameter	TA = -40°C		TA = 0°C		TA = +25°C			TA = +85°C		Unit
		Min.	Max.	Min.	Max.	Min.	Typ.	Max.	Min.	Max.	
f _{MAX}	Max. Toggle Frequency	1.1	—	1.1	—	1.1	—	—	1.1	—	GHz
t _{PLH} t _{PHL}	Propagation Delay CLK to Output S, R	480 450	680 670	490 450	690 670	500 450	— —	700 670	520 450	720 670	ps
t _S	Set-Up Time, D	200	—	200	—	200	—	—	200	—	ps
t _H	Hold Time, D	150	—	150	—	150	—	—	150	—	ps
t _{RR}	Reset Recovery Time	300	—	300	—	300	—	—	300	—	ps
t _{PW}	Minimum Pulse Width CLK, Set, Reset	400	—	400	—	400	—	—	400	—	ps
V _{CMR}	Common Mode Range ⁽¹⁾										V
	<500mV	-2.0	-0.4	-2.1	-0.4	-2.1	—	-0.4	-2.1	-0.4	
	≥500mV	-1.8	-0.4	-1.9	-0.4	-1.9	—	-0.4	-1.9	-0.4	
V _{PP (AC)}	Minimum Input Swing ⁽²⁾	150	—	150	—	150	—	—	150	—	mV
t _r t _f	Output Rise/Fall Time Q (20–80%)	280	550	280	550	280	330	550	280	550	ps

NOTES:

- V_{CMR} is referenced to the most positive side of the differential input signal. Normal operation is obtained when the input signals are within the V_{CMR} range and the input swing is greater than V_{PP (Min.)} and <1V. The lower end of the V_{CMR} range varies 1:1 with V_{EE}. The numbers in the spec table assume a nominal V_{EE} = -3.3V. Note for PECL operation, the V_{CMR (Min)} will be fixed at 3.3V - |V_{CMR (Min)}|.
- Minimum input swing for which AC parameters are guaranteed.

PRODUCT ORDERING CODE

Ordering Code	Package Type	Operating Range
SY100EL29VZC	Z20-1	Commercial
SY100EL29VZCTR	Z20-1	Commercial

20 LEAD SOIC .300" WIDE (Z20-1)

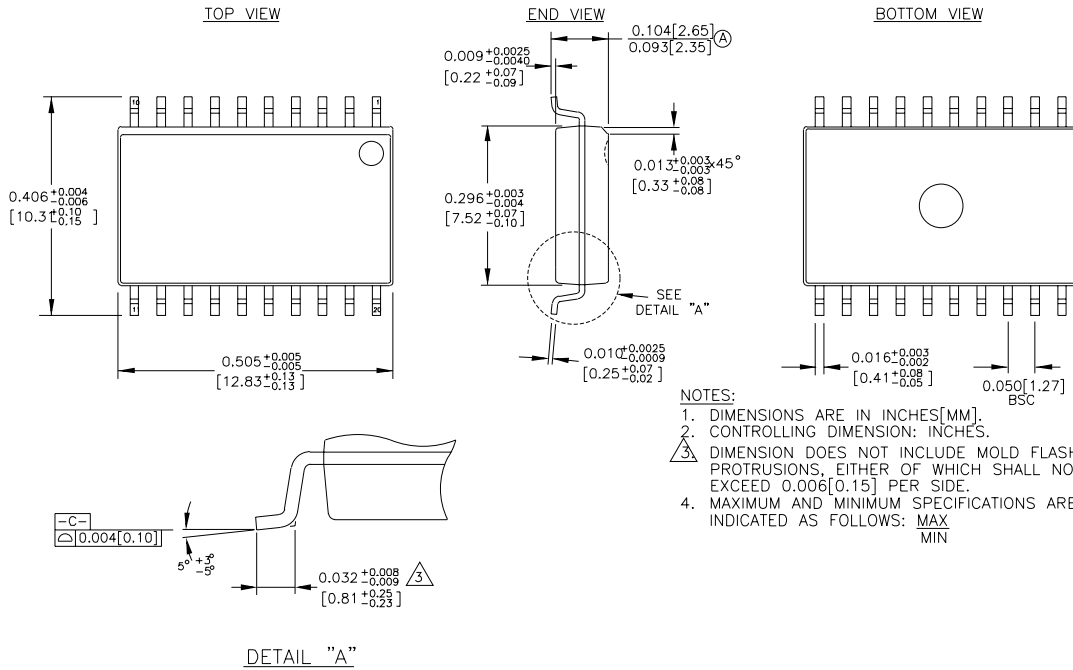

Rev. 03

MICREL-SYNERGY 3250 SCOTT BOULEVARD SANTA CLARA CA 95054 USA

TEL + 1 (408) 980-9191 FAX + 1 (408) 914-7878 WEB <http://www.micrel.com>

This information is believed to be accurate and reliable, however no responsibility is assumed by Micrel for its use nor for any infringement of patents or other rights of third parties resulting from its use. No license is granted by implication or otherwise under any patent or patent right of Micrel Inc.

© 2000 Micrel Incorporated