



## MJE3055T

### NPN SILICON TRANSISTOR

## HIGH VOLTAGE TRANSISTOR

### DESCRIPTION

The UTC **MJE3055T** is designed for general purpose of amplifier and switching applications.

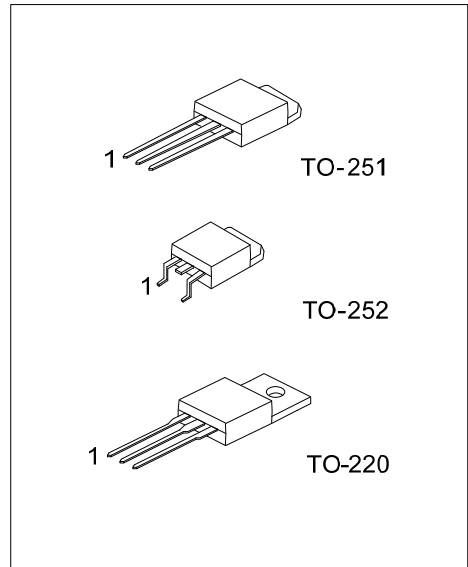

Lead-free: MJE3055TL  
Halogen-free: MJE3055TG

### ORDERING INFORMATION

Ordering Number			Package	Pin Assignment			Packing
Normal	Lead Free Plating	Halogen Free		1	2	3	
MJE3055T-TA3-T	MJE3055TL-TA3-T	MJE3055TG-TA3-T	TO-220	B	C	E	Tube
MJE3055T-TM3-T	MJE3055TL-TM3-T	MJE3055TG-TM3-T	TO-251	B	C	E	Tube
MJE3055T-TN3-R	MJE3055TL-TN3-R	MJE3055TG-TN3-R	TO-252	B	C	E	Tape Reel

<p>MJE3055TL-TA3-T</p> <p>(1)Packing Type</p> <p>(2)Package Type</p> <p>(3)Lead Plating</p>	<p>(1) R: Tape Reel, T: Tube</p> <p>(2) TA3: TO-220, TM3: TO-251, TN3: TO-252</p> <p>(3)G: Halogen Free, L: Lead Free, Blank: Pb/Sn</p>
---------------------------------------------------------------------------------------------	-----------------------------------------------------------------------------------------------------------------------------------------

■ ABSOLUTE MAXIMUM RATINGS ( $T_C=25^\circ\text{C}$ , unless otherwise specified)

PARAMETER		SYMBOL	RATINGS	UNIT
Collector-Base Voltage		$V_{CBO}$	70	V
Collector-Emitter Voltage		$V_{CEO}$	60	V
Emitter-Base Voltage		$V_{EBO}$	5	V
Total Power Dissipation	TO-220	$P_D$	75	W
	TO-251/TO-252		20	W
Collector Current		$I_C$	10	A
Base Current		$I_B$	6	A
Junction Temperature		$T_J$	150	$^\circ\text{C}$
Storage Temperature		$T_{STG}$	-55 ~ +150	$^\circ\text{C}$

Note: Absolute maximum ratings are those values beyond which the device could be permanently damaged.

Absolute maximum ratings are stress ratings only and functional device operation is not implied.

■ ELECTRICAL CHARACTERISTICS ( $T_a=25^\circ\text{C}$ , unless otherwise specified)

PARAMETER	SYMBOL	TEST CONDITIONS	MIN	TYP	MAX	UNIT
Collector-Emitter Breakdown Voltage	$BV_{CEO}$	$I_C=200\text{mA}$	60			V
Collector-Base Breakdown Voltage	$BV_{CBO}$	$I_C=10\text{mA}$	70			V
Emitter-Base Breakdown Voltage	$BV_{EBO}$	$I_E=10\text{mA}$	5			V
Collector Cut-off Current	$I_{CBO}$	$V_{CB}=70\text{V}$			1	mA
	$I_{CEO}$	$V_{CE}=30\text{V}$			700	$\mu\text{A}$
	$I_{CEX}$	$V_{CE}=70\text{V}, V_{EB(OFF)}=1.5\text{V}$			1	mA
Emitter Cut-off Current	$I_{EBO}$	$V_{EB}=5\text{V}$			5	mA
Collector-Emitter Saturation Voltage (Note)	$V_{CE(SAT)1}$	$I_C=4\text{A}, I_B=0.4\text{A}$			1.1	V
	$V_{CE(SAT)2}$	$I_C=10\text{A}, I_B=3.3\text{A}$			8	V
Base-Emitter on Voltage	$V_{BE(ON)}$	$V_{CE}=4\text{V}, I_C=4\text{A}$			1.8	V
DC Current Gain (Note)	$h_{FE1}$	$V_{CE}=4\text{V}, I_C=4\text{A}$	20		100	
	$h_{FE2}$	$V_{CE}=4\text{V}, I_C=10\text{A}$	5			
Current Gain Bandwidth Product	$f_T$	$V_{CE}=10\text{V}, I_C=0.5\text{A}, f=1\text{MHz}$	2			MHZ

Note: Pulse test:  $PW \leq 300\mu\text{s}$ , duty cycle  $\leq 2\%$  Pulse

UTC assumes no responsibility for equipment failures that result from using products at values that exceed, even momentarily, rated values (such as maximum ratings, operating condition ranges, or other parameters) listed in products specifications of any and all UTC products described or contained herein. UTC products are not designed for use in life support appliances, devices or systems where malfunction of these products can be reasonably expected to result in personal injury. Reproduction in whole or in part is prohibited without the prior written consent of the copyright owner. The information presented in this document does not form part of any quotation or contract, is believed to be accurate and reliable and may be changed without notice.