

High Performance Electrical Double-Layer Capacitors

DMF Series



To meet consumer demand for mobile devices with greater efficiency and functionality, Murata began focusing its R&D efforts on Electrical Double-Layer Capacitors (EDLC) in 2008, at which time we made a strategic decision to license leading-edge supercapacitor technology from CAP-XX Limited (CAP-X), an Australia-based firm. Working from this collaborative basis, Murata has enhanced the design and manufacture of these high power (low ESR) EDLCs in a compact, slim package, and we continue our research efforts to develop even better and higher performing products.

Electrical Double-Layer Capacitors (EDLCs), often referred to as supercapacitors, are energy storage devices with high power density characteristics that are up to 1,000 times greater than what is typically found in conventional capacitor technology. Murata's Electrical Double Layer Capacitor combines these advanced characteristics in a small and slim module. Optimization of electrochemical systems, including the electrode structure, enables flexible charging and discharging from high to low output over a range of temperatures. By supporting



momentary peak load, the components also level battery load and can drive high-output functions that are difficult for batteries alone.

Features

- High power output and high energy: 5.5V
- Compact and slim: 21.0mm x 14.0mm x 2.5mm
- Wide operation temperature range from -30°C to +70°C
- Low ESR: 40mΩ – 60mΩ
 - Stable ESR at lower temperatures
- ESR change @ -30°C < twice the nominal ESR
- Low leakage current
 - Typical leakage less than 10μA@96hrs
- Long cycle life - exceeding 100k cycles

Benefits

- Leveling the high peak load up to hundreds of milli-seconds
 - Extend battery run time and cycle life by stable combination with EDLC
 - Enable the use of lower power battery or reduction of the number of series connections
 - Enable the use of high peak load applications without high power battery
- Quick Charge and Discharge of High Energy
 - Secure power line from large load change and power down
 - Secure battery power down at lower temperatures
 - Shorten the standby time
- Maintenance-free energy storage device with flexible charge

Applications



- Peak Power Assist
 - LED flash (DVC, DSC, smart phones), valve operation (smart meters), e-paper applications
- Backup Applications
 - Solid state drives, UPS, last gasp applications
- Energy Harvesting Systems
 - Micro and macro energy harvesting systems
- Battery Peak Load Leveling
 - Point of sale equipment, tablet PCs, audio, smart meters, GPS/GPRS tracking systems, fuel cells, primary cell equipment, power tools

Product Lineup

Series	Murata Part Number	Rated Voltage	Nominal ESR@1kHz	Nominal Capacitance	T	Operating Temperature
DMF	DMF3R5R5L334M3DTA0	Peak 5.5V Constant 4.2V	60mΩ	330mF	2.5 ±0.2mm	Min: - 30°C Max: +70°C
	DMF3Z5R5H474M3DTA0	Peak 5.5V Constant 4.2V	40mΩ	470mF	3.2 ±0.2mm	

Part Number Description

DMF **3R** **5R5** **L** **334** **M** **3D** **T** **A0**

① ② ③ ④ ⑤ ⑥ ⑦ ⑧ ⑨

1. Series

DMF	High Peak Power Type (smaller size)
-----	-------------------------------------

2. External Dimension (L×W×T) (mm)

Code	L	W	T
3R	21.0±0.5	14.0±0.5	2.5±0.2
3Z	21.0±0.5	14.0±0.5	3.2±0.2

3. Rated Voltage

Expressed by three-digit alphanumerics

Code	Rated Voltage
5R5	5.5V (peak) / 4.2V(constant)

4. ESR

Code	ESR @1kHz
H	40mΩ
L	60mΩ

5. Nominal Capacitance

Code	Nominal Capacitance
334	33×10 ⁴ μF=330mF
474	47×10 ⁴ μF=470mF

6. Capacitance Tolerance

Code	Tolerance
M	±20%

7. External Terminal

Code	Terminal Specification
3D	3 Terminals (+ - / Balance)

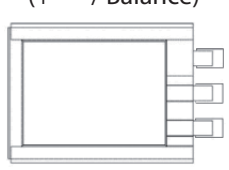

8. Packing Code

Code	Packing Specification
T	Tray Type, 50pcs/Tray

9. Inhouse Specification Code

Expressed by two-digit alphanumerics

Dimensions (mm)

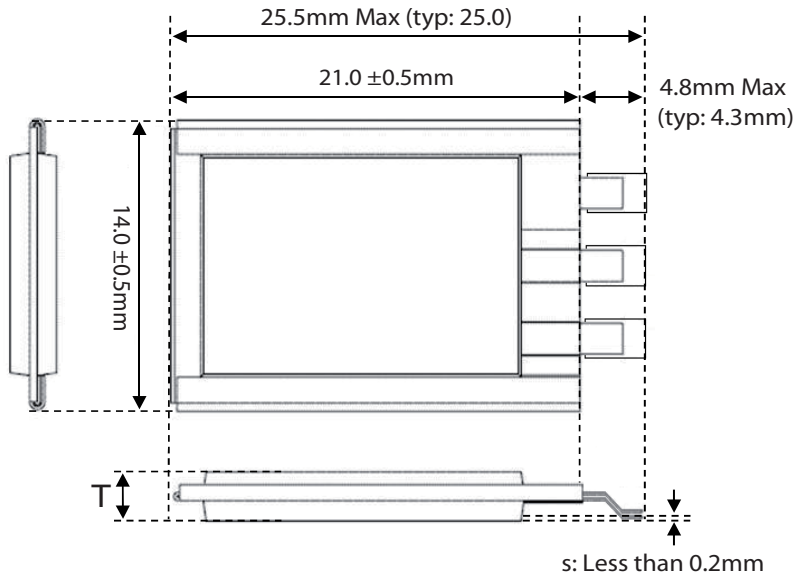

Land Pattern Design

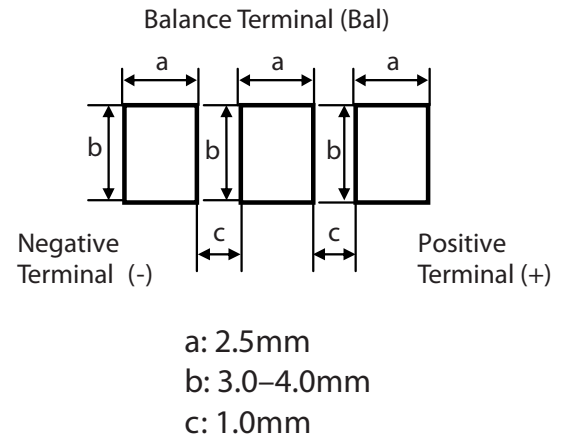

Marking

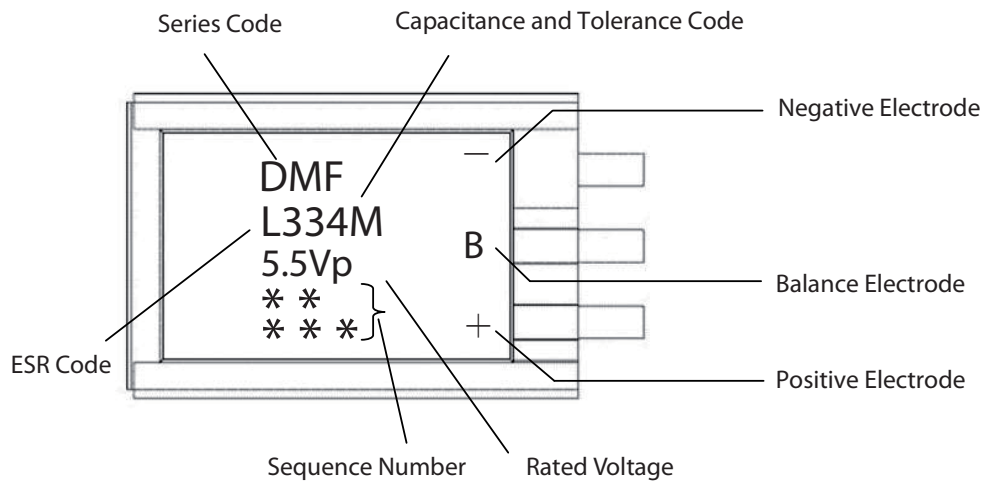

Performance and Validation Method

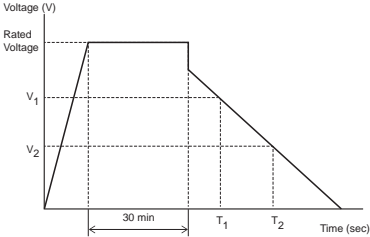
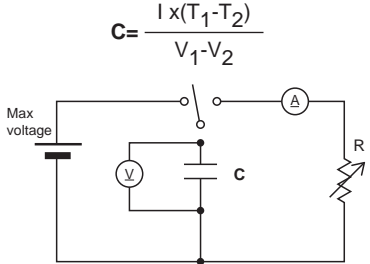
Item	Validation Method	Specification																					
Operating Temperature	-	-30°C to +70°C																					
Nominal Capacitance	<p>Discharge method</p> <ol style="list-style-type: none"> Charge capacitor for 30min at rated peak voltage 5.5V. Then discharge  <p>V1: 80% of rated peak voltage V2: 40% of rated peak voltage T1: Time with voltage V1 T2: Time with voltage V2 Discharge current: 100mA</p> $C = \frac{I \times (T_1 - T_2)}{V_1 - V_2}$ 	Please refer to Lineup list																					
ESR	<p>Impedance Method</p> <p>Measured at AC1kHz</p> <p>Current: 10mA - 200mA</p>	Please refer to Lineup list																					
Leakage Current @96hrs	-	Less than or equal to 10uA at 96hrs.																					
Temperature Characteristics	ESR: -30°C to +70°C	<p>Temperature characteristics</p> <table border="1"> <thead> <tr> <th></th> <th>ESR@1kHz</th> <th>Capacitance</th> </tr> </thead> <tbody> <tr> <td>70°C</td> <td>±30%</td> <td>±10%</td> </tr> <tr> <td>40°C</td> <td>±15%</td> <td>±10%</td> </tr> <tr> <td>25°C</td> <td>-</td> <td>-</td> </tr> <tr> <td>0°C</td> <td>+40% or less</td> <td>±10%</td> </tr> <tr> <td>-20°C</td> <td>+80% or less</td> <td>±10%</td> </tr> <tr> <td>-30°C</td> <td>+100% or less</td> <td>±10%</td> </tr> </tbody> </table>		ESR@1kHz	Capacitance	70°C	±30%	±10%	40°C	±15%	±10%	25°C	-	-	0°C	+40% or less	±10%	-20°C	+80% or less	±10%	-30°C	+100% or less	±10%
	ESR@1kHz	Capacitance																					
70°C	±30%	±10%																					
40°C	±15%	±10%																					
25°C	-	-																					
0°C	+40% or less	±10%																					
-20°C	+80% or less	±10%																					
-30°C	+100% or less	±10%																					
Charge-Discharge Cycle Test	<p>Charge voltage: 5.5V</p> <p>Charge: 0.5A</p> <p>Discharge: 5A 67msec</p> <p>Test Temperature: 70°C ±2°C</p> <p>Cycle number: 20,000 times</p>	<p>Capacitance change:</p> <ul style="list-style-type: none"> Under 80% of initial value <p>ESR change (@1kHz):</p> <ul style="list-style-type: none"> Under 130% of initial value 																					
High Temperature Loading	<p>70°C+2°C/-0°C</p> <p>1000 hrs+24hrs/-0hrs</p> <p>Applying hold voltage</p>	<p>ESR @1kHz: Under 130% of initial value</p> <p>Capacitance change: Over 70% of initial value</p>																					

Electrical Characteristics

Capacitance and ESR Temperature Characteristics

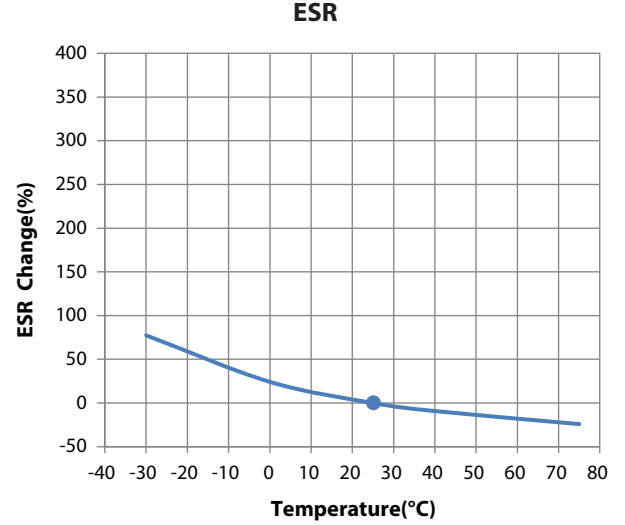
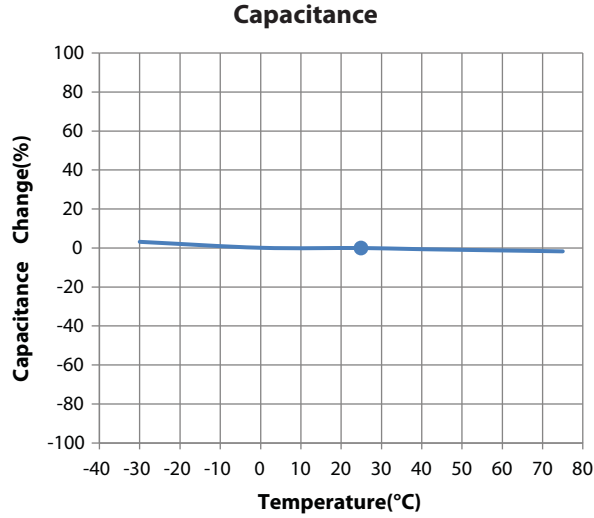

Leakage Current (@25°C)

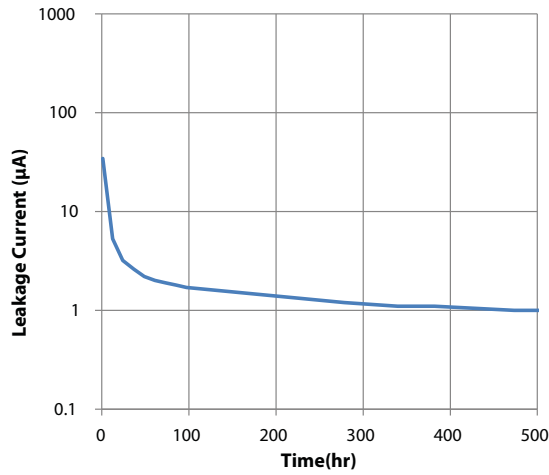

Discharge Characteristic

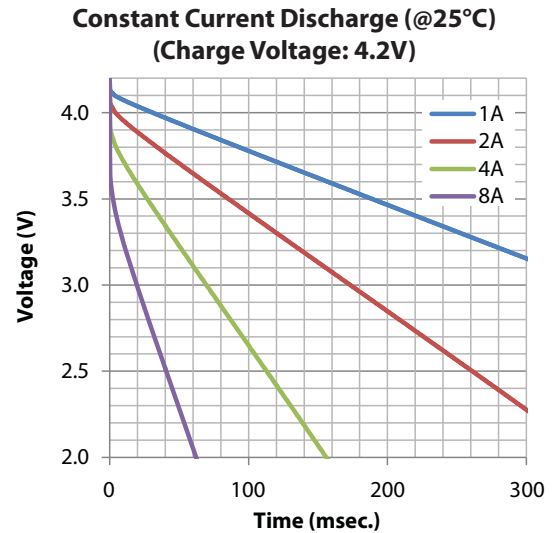
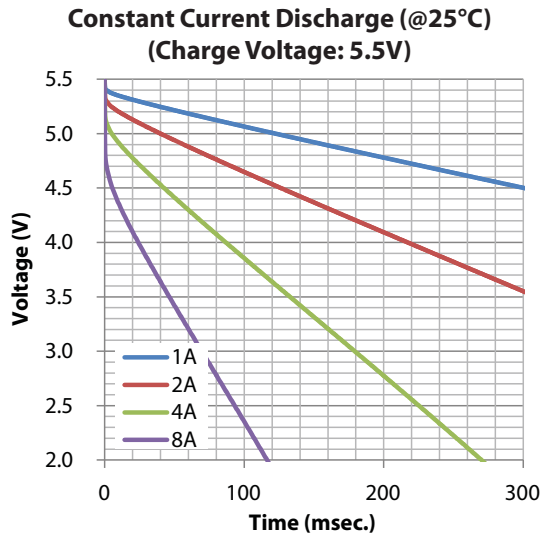

Electrical Characteristics, continued

Discharge Characteristic, continued

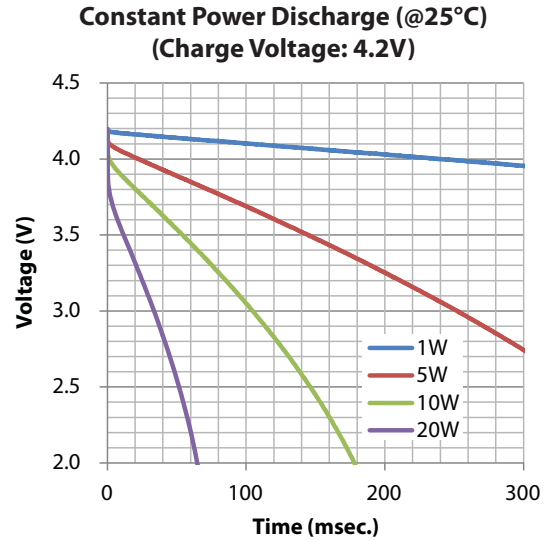
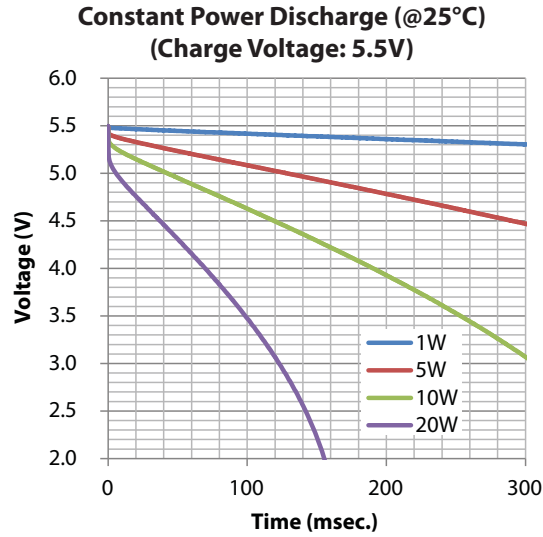

Charge Characteristic

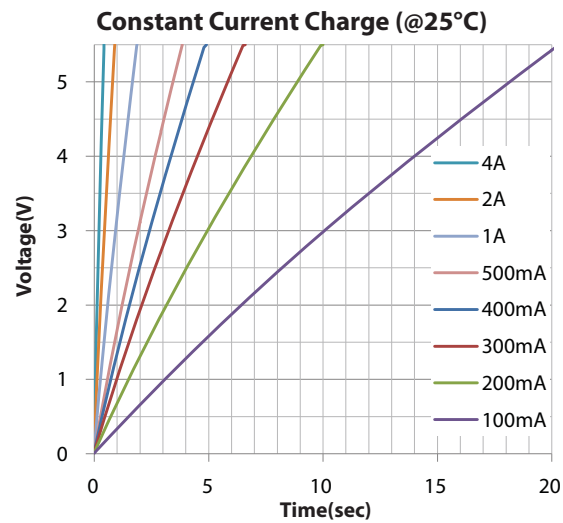

Electrical Characteristics, continued

High Temperature Loading DC

High Temperature Loading Test Condition: 4.2V@70°C

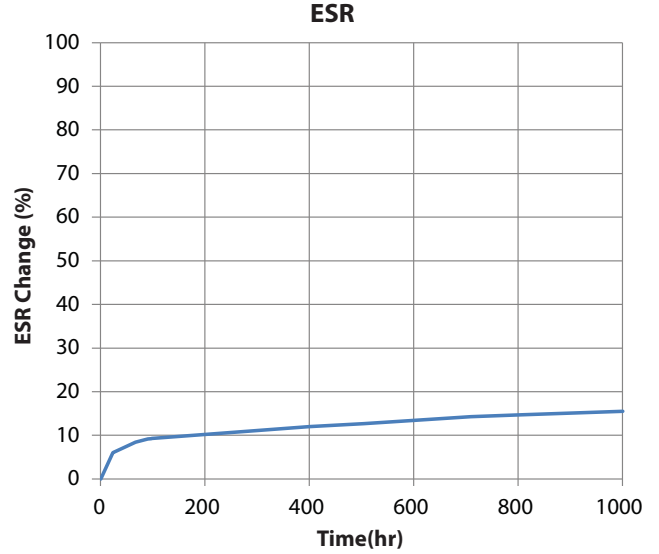
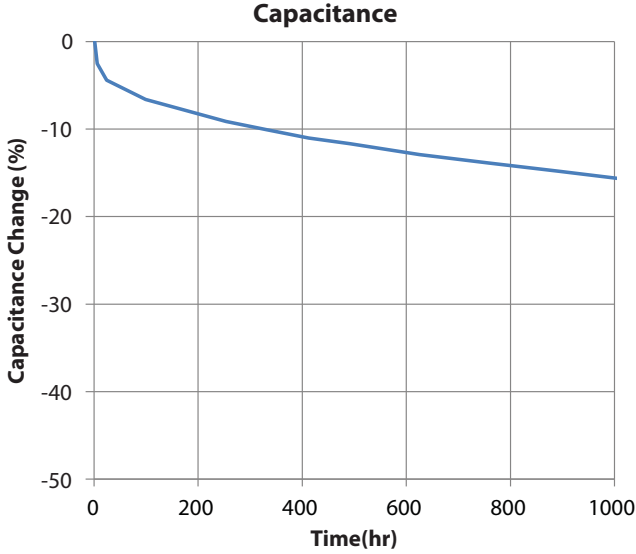

Charge-Discharge Cycle Characteristic (@70°C)

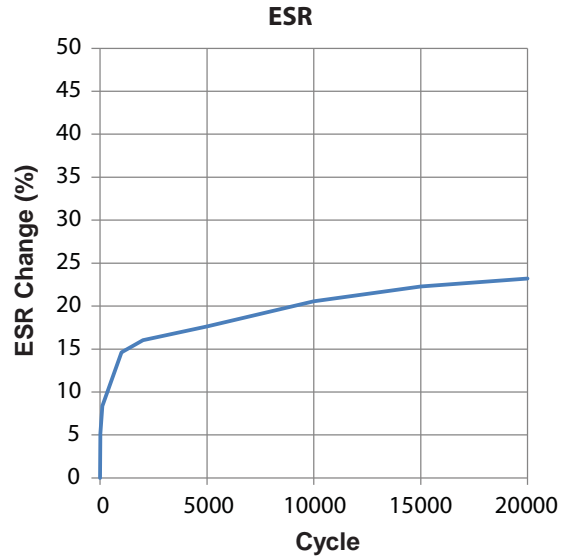
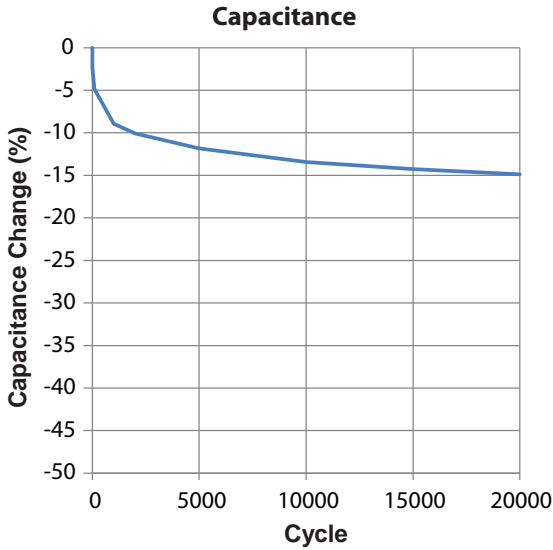

Caution Before Use

CAUTION

- *This device must be used within rated voltage. Over voltage may cause electrolyte leakage or swelling.*
- *This device has polarity. Please do not reverse polarity when in use. Reverse polarity may damage the electrolyte or electrode inside. Please verify the orientation of the capacitor before use in accordance with the markings of polarity on the products.*
- *Avoid outer case contact to ground plane, as this may cause leakage current failure.*
- *This device cannot be used under any acidic or alkaline environment.*
- *This device uses a relatively low vapor pressure liquid electrolyte. At high altitudes (with low external pressure), internal resistance or other performance may decrease. If you would like to use this product at high altitude, please consult a Murata representative first.*
- *DMF series product has two individual cells connected electrically in series. Please ensure that peak voltage is less than 2.75V per cell and less than 2.1V per cell for constant load. Murata strongly recommends the use of active balancing control circuits or balance resistors. For further details, contact your local Murata representative.*
- *When connecting two or more capacitors in series, voltage load may vary between capacitors. This could lead to excessive voltage on any capacitor. In these cases, please consult a Murata representative beforehand.*

CAUTION for Soldering and Assembling

- 1. These parts should not be soldered using re-flow or flow profiles. Please use connection methods that prevent exposure to temperatures beyond the maximum allowable range. These may include hand soldering, ultrasonic welding, etc.*
- 2. Please do not apply excessive force to the capacitor during insertion as well as after soldering. Excessive force may result in damage to electrode terminals and/or degradation of electrical performance.*
- 3. Hand Soldering*

Please solder under the following conditions:
Soldering iron temperature at 350°C ±10°C;
Solder iron wattage: 70W or less;
Soldering time: 3.0+1/-0sec.
Allowable soldering passes: 3 times/device – allow at least for 15 seconds between successive soldering.
Please do not touch laminate package directly with the soldering iron.
- 4. Do not wash the device after soldering.*

Packaging

Tray(50 pcs/ Tray)

Min Packaging Quantity (500pcs)

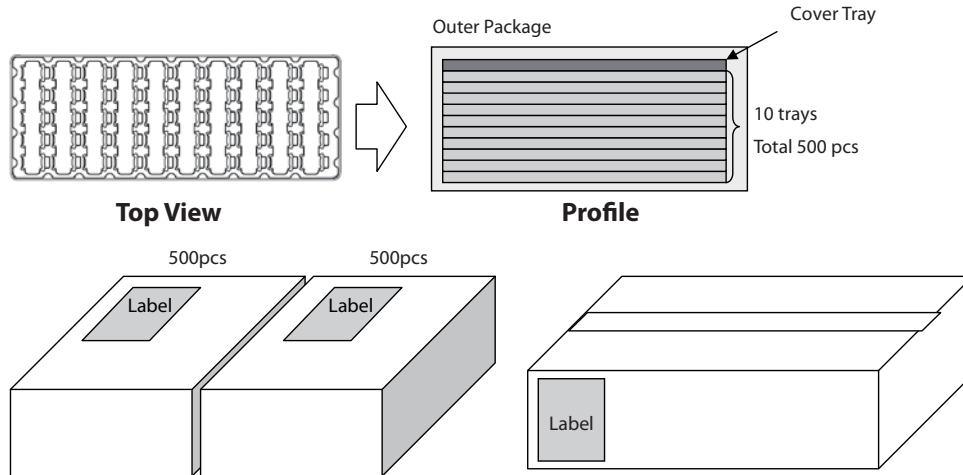

Minimum Shipping Quantity: 500 pcs

Storage Conditions

Storage condition without opening outer package:
30°C 60%RH for 1 year (before opening outer package)
*Note: This product cannot be baked.

- Storage conditions after opening outer package:
1. Term of warranty is 3 months after sealed package is opened.
 2. Storage environment
 - Please adhere to the following conditions in sealed package:
 - Temperature: 5 to 35°C; and
 - Humidity: no more than 70%RH with no condensation.
 - Avoid any acidic or alkaline environments.
 - Avoid excessive external force while in storage.
 3. Keep device in sealed plastic package before use.
 4. Do not apply any heat treatment before use.

Response to IATA Dangerous Goods Regulations

According to the 54th Edition of IATA Dangerous Goods Regulations effective from January 1, 2013, Electrical Double-Layer Capacitors (ELDCs) with an energy storage capacity greater than 0.3 Wh are treated as dangerous goods and introduced as UN3499 in Class 9.

However, the energy storage capacity of each of Murata's EDLCs is not greater than 0.3. Therefore, Murata's EDLCs are not covered by this regulation.

High Performance Electrical Double-Layer Capacitors

Note 

1. Export Control

<For customers outside Japan>

No Murata products should be used or sold, through any channels, for use in the design, development, production, utilization, maintenance or operation of, or otherwise contribution to (1) any weapons (Weapons of Mass Destruction [nuclear, chemical or biological weapons or missiles] or conventional weapons) or (2) goods or systems specially designed or intended for military end-use or utilization by military end-users.

For products which are controlled items subjects to the “Foreign Exchange and Foreign Trade Law” of Japan, the export license specified by the law is required for export.

2. Please contact our sales representatives or product engineers before using the products in this catalog for the applications listed below, which require especially high reliability for the prevention of defects which might directly damage a third party’s life, body or property, or when one of our products is intended for use in applications other than those specified in this catalog.

- | | |
|-----------------------------|--|
| ① Aircraft equipment | ② Aerospace equipment |
| ③ Undersea equipment | ④ Power plant equipment |
| ⑤ Medical equipment | ⑥ Transportation equipment (vehicles, trains, ships, etc.) |
| ⑦ Traffic signal equipment | ⑧ Disaster prevention/crime prevention equipment |
| ⑨ Data-processing equipment | ⑩ Application of similar complexity and/or reliability requirements to the applications listed above |

3. Product specifications in this catalog are current as of December 2012. They are subject to change or our products in it may be discontinued without advance notice.

Please check with our sales representatives or product engineers before ordering or if there are any additional questions.

4. Due to space constraints, this catalog only includes limited detailed specifications. Therefore, please review our product specifications or approval sheet for specifications before ordering, particularly rating and caution (for storage, operating, rating, soldering, mounting and handling) background to prevent smoking and/or burning, etc.

5. Please note that unless otherwise specified, we shall assume no responsibility whatsoever for any conflict or dispute that may occur in connection with the effect of our and/or a third party’s intellectual property rights and other related rights in consideration of your use of our products and/or information described or contained in our catalogs. In this connection, no representation shall be made to the effect that any third parties are authorized to use the rights mentioned above under licenses without our consent.

6. No ozone depleting substances (ODS) under the Montreal Protocol are used in our manufacturing process.

muRata

Innovator in Electronics

muRata **Murata Manufacturing Co., Ltd.**

Head Office

1-10-1, Higashi Kotari 1-chome
Nagaokakyo-shi, Kyoto
617-8555, Japan
Phone: 81-75-951-9111

International Division

3-29-12, Shibuya 3-chome,
Shibuya-ku, Tokyo
150-0002 Japan
Phone: 81-3-5469-6123

Murata Americas

Murata Electronics N.A., Inc. (Regional HQ)
2200 Lake Park Drive
Smyrna, GA 30080-7604, USA.
Phone: 1-770-436-1300
Fax: 1-770-436-3030

For additional information visit:
www.murataamericas.com/edlc

Murata (China) Investment Co., Ltd.

Lane 318 Yonghe Road
Zhabei District, Shanghai 200072, China
Phone: 86-21-3205-4616
Fax: 86-21-3205-4617

Murata Europe

Murata Electronics Europe B.V. (Regional HQ)
Daalmeerstraat 4, 2131HC Hoofddorp
The Netherlands
Phone: +31-(0)23-5698360
Fax: +31-(0)23-5698361

Taiwan Murata Electronics Co., Ltd.

No 225 Chung - Chin Road, Taichung, Taiwan
Phone: 886-4-2425-4151

Murata Electronics Singapore (Pte.) Ltd.

200 Yishun Avenue 7
Singapore, 768927
Tel: 65-6758-4233
Fax: 65-6758-2026

