

Preliminary Information

5.2 A H-Bridge

The 33886 is a monolithic H-Bridge ideal for fractional horsepower DC-motor and bi-directional thrust solenoid control. The IC incorporates internal control logic, charge pump, gate drive, and low $R_{DS(ON)}$ MOSFET output circuitry. The 33886 is able to control continuous inductive DC load currents to 5.2 A. Output loads can be Pulse Width Modulation (PWM) controlled at frequencies to 10 kHz.

A Fault Status output reports undervoltage, overcurrent, and overtemperature conditions. Two independent inputs control the two half-bridge totem-pole outputs. Two disable inputs force the outputs to tristate (exhibit high impedance).

The 33886 is parametrically specified over a temperature range of $-40^{\circ}\text{C} \leq T_A \leq 125^{\circ}\text{C}$, $5.0\text{ V} \leq V_{PWR} \leq 28\text{ V}$, and is available in an economical surface mount package.

Features

- Direct Replacement for MC33186DH1 in the HSOP20 Package
- 5.0 V to 36 V Operation
- $120\text{ m}\Omega$ $R_{DS(ON)}$ H-Bridge Switches
- TTL/CMOS Compatible Inputs
- PWM Frequencies to 10 kHz
- Automatic PWM Overcurrent Limiting
- Output Short Circuit Protection
- Overtemperature Output Current Reduction with Shutdown
- Undervoltage Shutdown
- Fault Status Reporting

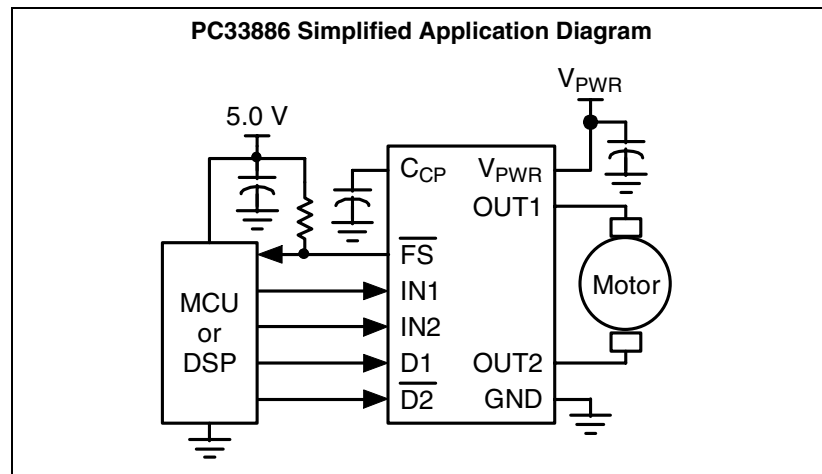

PC33886

5.2 A H-BRIDGE

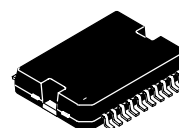

DH SUFFIX
20-LEAD
HSOP
CASE 979C

PIN CONNECTIONS

- 1 AGND
- 2 $\overline{\text{FS}}$
- 3 IN1
- 4 V_{PWR}
- 5 V_{PWR}
- 6 OUT1
- 7 OUT1
- 8 DNC
- 9 PGND
- 10 PGND
- 11 PGND
- 12 $\overline{\text{PGND}}$
- 13 $\overline{\text{D2}}$
- 14 OUT2
- 15 OUT2
- 16 V_{PWR}
- 17 C_{CP}
- 18 D1
- 19 IN2
- 20 DNC

ORDERING INFORMATION

Device	Temperature Range (T_A)	Package
PC33886DH/R2	-40 to 125°C	20 HSOP

This document contains information on a product under development. Motorola reserves the right to change or discontinue this product without notice.

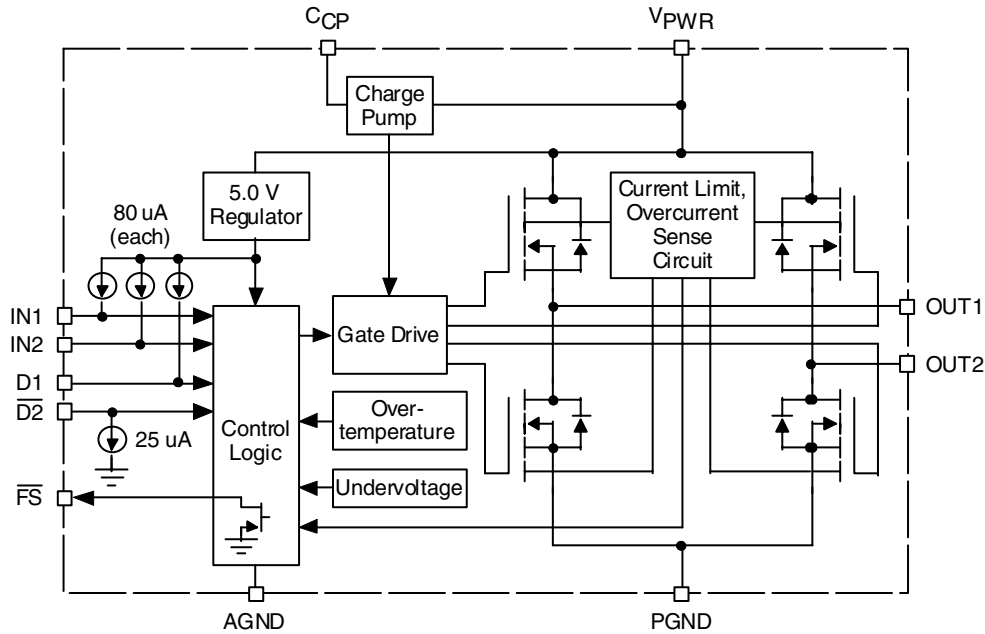

Figure 1. PC33886 Internal Block Diagram

PIN FUNCTION DESCRIPTION

HSOP	Pin Name	Description
1	AGND	Low current Analog signal ground.
2	\overline{FS}	Open drain active LOW Fault Status output requiring a pull-up resistor to 5.0 V.
3	IN1	True Logic input control of OUT1 (i.e., IN1 logic HIGH = OUT1 HIGH).
4, 5, 16	V_{PWR}	Positive power source connection.
6, 7	OUT1	H-Bridge output 1.
8, 20	DNC	Connect these pins to ground in the application. They are test mode pins used in manufacturing only.
9–12	PGND	Device high current power ground.
13	$\overline{D2}$	Active LOW input used to simultaneously tristate disable both H-Bridge outputs. When $\overline{D2}$ is Logic LOW, both outputs are tristate.
14, 15	OUT2	H-Bridge output 2.
17	C_{CP}	External reservoir capacitor connection for internal Charge Pump.
18	D1	Active HIGH input used to simultaneously tristate disable both H-Bridge outputs. When D1 is Logic HIGH, both outputs are tristate.
19	IN2	True Logic input control of OUT2 (i.e., IN2 logic HIGH = OUT2 HIGH).

MAXIMUM RATINGS

All voltages are with respect to ground unless otherwise noted.

Rating	Symbol	Value	Unit
Power Supply Voltage Normal Operation (Steady-State) Transient (Note 1)	$V_{PWR(SS)}$ $V_{PWR(t)}$	36 40	V
Input Voltage (Note 2)	V_{IN}	7.0	V
\overline{FS} Status Output (Note 3)	$V_{\overline{FS}}$	7.0	V
Continuous Output Current (Note 4)	$I_{OUT(CONT)}$	5.2	A
ESD Voltage Human Body Model (Note 5) Machine Model (Note 6)	V_{ESD1} V_{ESD2}	2000 200	V
Storage Temperature	T_{STG}	-65 to 150	°C
Ambient Temperature (Note 7)	T_A	-40 to 125	°C
Operating Junction Temperature	T_J	-40 to 150	°C
Lead Soldering Temperature (Note 8)	T_{SOLDER}	260	°C
Approximate Junction-to-Board Thermal Resistance (Note 9)	$R_{\theta J-B}$	~5.0	°C/W

Notes:

1. Device will survive the transient overvoltage indicated for a maximum duration of 500 ms.
2. Exceeding the input voltage on IN1, IN2, D1, or $\overline{D2}$ may cause a malfunction or permanent damage to the device.
3. Exceeding the pull-up resistor voltage on the open Drain \overline{FS} pin may cause permanent damage to the device.
4. Continuous output current capability so long as junction temperature is $\leq 150^\circ\text{C}$.
5. ESD1 testing is performed in accordance with the Human Body Model ($C_{ZAP} = 100 \text{ pF}$, $R_{ZAP} = 1500 \Omega$).
6. ESD2 testing is performed in accordance with the Machine Model ($C_{ZAP} = 100 \text{ pF}$, $R_{ZAP} = 0 \Omega$).
7. The limiting factor is junction temperature, taking into account the power dissipation, thermal resistance, and heat sinking.
8. Lead soldering temperature limit is for 10 seconds maximum duration. Not designed for immersion soldering. Exceeding these limits may cause malfunction or permanent damage to the device.
9. Exposed heat sink pad plus the power and ground terminals comprise the main heat conduction paths. The actual $R_{\theta J-B}$ (junction-to-PC board) values will vary depending on solder thickness and composition and copper trace.

STATIC ELECTRICAL CHARACTERISTICS

Characteristics noted under conditions $5.0\text{ V} \leq V_{\text{PWR}} \leq 28\text{ V}$ and $-40^\circ\text{C} \leq T_{\text{A}} \leq 125^\circ\text{C}$, unless otherwise noted. Typical values noted reflect the approximate parameter mean at $T_{\text{A}} = 25^\circ\text{C}$ under nominal conditions, unless otherwise noted.

Characteristic	Symbol	Min	Typ	Max	Unit
Power Supply					
Operating Voltage Range					
Steady-State (Note 10)	$V_{\text{PWR(SS)}}$	5.0	–	36	V
Transient ($t < 500\text{ ms}$) (Note 11)	$V_{\text{PWR(t)}}$	–	–	40	V
Standby Supply Current					
$V_{\text{EN}} = 5.0\text{ V}$, $I_{\text{LOAD}} = 0\text{ A}$	$I_{\text{PWR(standby)}}$	–	–	20	mA
Threshold Supply Voltage					
Switch-OFF	$V_{\text{PWR(thres-OFF)}}$	4.15	4.4	4.65	V
Switch-ON	$V_{\text{PWR(thres-ON)}}$	4.5	4.75	5.0	V
Hysteresis	$V_{\text{PWR(hys)}}$	150	–	–	mV
Charge Pump					
Charge Pump Voltage					
$V_{\text{PWR}} = 4.15\text{ V}$	$V_{\text{CP}} - V_{\text{PWR}}$	3.35	–	–	V
$V_{\text{PWR}} < 40\text{ V}$		–	–	20	V
Control Inputs					
Input Voltage (IN1, IN2, D1, $\overline{\text{D2}}$)					
Threshold HIGH	V_{IH}	3.5	–	–	V
Threshold LOW	V_{IL}	–	–	1.4	V
Hysteresis	V_{HYS}	0.7	1.0	–	V
Input Current (IN1, IN2, D1) (Note 12)					
$V_{\text{IN}} = 0\text{ V}$	I_{IN}	-200	-80	–	μA
$\overline{\text{D2}}$ Input Current (Note 13)					
$V_{\overline{\text{D2}}} = 5.0\text{ V}$	$I_{\overline{\text{D2}}}$	–	25	100	μA

Notes:

10. Parameter is guaranteed by design but not production tested.
11. Device will survive the transient overvoltage indicated for a maximum duration of 500 ms.
12. Inputs IN1, IN2 and D1 have independent internal pull-up current sources.
13. The $\overline{\text{D2}}$ input incorporates an active internal pull-down current sink.

STATIC ELECTRICAL CHARACTERISTICS

Characteristics noted under conditions $5.0\text{ V} \leq V_{PWR} \leq 28\text{ V}$ and $-40^\circ\text{C} \leq T_A \leq 125^\circ\text{C}$, unless otherwise noted. Typical values noted reflect the approximate parameter mean at $T_A = 25^\circ\text{C}$ under nominal conditions, unless otherwise noted.

Characteristic	Symbol	Min	Typ	Max	Unit
----------------	--------	-----	-----	-----	------

Power Outputs (OUT1, OUT2)

Output-ON Resistance (Note 14) $5.0\text{ V} < V_{PWR} < 28\text{ V}$, $T_J = 25^\circ\text{C}$ $8.0\text{ V} < V_{PWR} < 28\text{ V}$, $T_J = 150^\circ\text{C}$ $5.0\text{ V} < V_{PWR} < 8.0\text{ V}$, $T_J = 150^\circ\text{C}$	R_{OUT}	–	120	–	m Ω
		–	–	225	m Ω
		–	–	300	m Ω
Output Latch-OFF Current (Note 15)	$I_{LATCH-OFF}$	5.2	6.5	7.8	A
Output Latch-OFF Time	t_a	15	20.5	26	μs
Output Blanking Time	t_b	12	16.5	21	μs
High-Side Overcurrent Detection	$I_{OCD(H)}$	11	–	–	A
Low-Side Overcurrent Detection	$I_{OCD(L)}$	8.0	–	–	A
Leakage Current (Note 16) $V_{OUT} = V_{PWR}$ $V_{OUT} = \text{GND}$	$I_{OUT(leak)}$	–	100	200	μA
		–	30	60	μA
Free-Wheeling Diode Forward Voltage Drop (Note 17) $I_{OUT} = 3.0\text{ A}$	V_F	–	–	2.0	V
Free-Wheeling Diode Reverse Recovery Time (Note 17)	t_{rr}	100	–	–	ns
Switch-OFF Thermal Shutdown Hysteresis	T_{LIM} T_{HYS}	175 –	– 15	– –	$^\circ\text{C}$ $^\circ\text{C}$

Fault Status (Note 18)

Fault Status Leakage Current (Note 19) $V_{FS} = 5.0\text{ V}$	$I_{FS(leak)}$	–	–	10	μA
Fault Status SET Voltage (Note 20) $I_{FS} = 300\text{ }\mu\text{A}$	$V_{FS(LOW)}$	–	–	1.0	V

Notes:

- Output-ON resistance as measured from output to V_{PWR} and GND.
- Future product will exhibit the values indicated in this table. Interim product exhibits a minimum of 6.0 A and a maximum of 8.5 A.
- Outputs switched OFF with D1 or $\overline{D2}$.
- Parameter is guaranteed by design but not production tested.
- Fault Status output is an open Drain output requiring a pull-up resistor to 5.0 V.
- Fault Status Leakage Current is measured with Fault Status HIGH and *not* SET.
- Fault Status Set Voltage is measured with Fault Status LOW and SET with $I_{FS} = 300\text{ }\mu\text{A}$.

DYNAMIC ELECTRICAL CHARACTERISTICS

Characteristics noted under conditions $5.0\text{ V} \leq V_{\text{PWR}} \leq 28\text{ V}$ and $-40^\circ\text{C} \leq T_{\text{A}} \leq 125^\circ\text{C}$, unless otherwise noted. Typical values noted reflect the approximate parameter mean at $T_{\text{A}} = 25^\circ\text{C}$ under nominal conditions, unless otherwise noted.

Characteristic	Symbol	Min	Typ	Max	Unit
Timing Characteristics					
PWM Frequency (Note 21)	f_{PWM}	–	–	10	kHz
Maximum Switching Frequency During Current Limit (Note 22)	f_{MAX}	–	–	20	kHz
Output ON Delay (Note 23) $V_{\text{PWR}} = 14\text{ V}$	$t_{\text{d(ON)}}$	–	–	18	μs
Output OFF Delay (Note 23) $V_{\text{PWR}} = 14\text{ V}$	$t_{\text{d(OFF)}}$	–	–	18	μs
Output Rise and Fall Time (Note 24) $V_{\text{PWR}} = 14\text{ V}, I_{\text{out}} = 3.0\text{ A}$	$t_{\text{f}}, t_{\text{r}}$	2.0	5.0	8.0	μs
Disable Delay Time (Note 25)	$t_{\text{d(disable)}}$	–	–	8.0	μs
Over-Current/Temperature Turn-OFF Time (Note 26)	t_{FAULT}	–	4.0	–	μs
Power-OFF Delay Time	t_{pod}	–	1.0	5.0	ms

Notes:

- The outputs can be PWM controlled from an external source. The PWM Frequency is the externally induced output switching frequency, the maximum of which is limited by the internal charge pump.
- The Maximum Switching Frequency during Current Limit is internally implemented. The internal control produces a constant OFF-time PWM of the output. The output load current effects the Maximum Switching Frequency.
- Output Delay is the time duration from the midpoint of the IN1 or IN2 input signal to the 10% or 90% point (dependent on the transition direction) of the OUT1 or OUT2 signal. If the output is transitioning HIGH-to-LOW, the delay is from the midpoint of the input signal to the 90% point of the output response signal. If the output is transitioning LOW-to-HIGH, the delay is from the midpoint of the input signal to the 10% point of the output response signal. See Figure 3.
- Rise Time is from the 10% to the 90% level and Fall Time is from the 90% to the 10% level of the output signal. See Figure 4.
- Disable Delay Time is the time duration from the midpoint of the D (disable) input signal to 10% of the output tristate response. See Figure 3.
- Increasing output currents will become limited at 6.5 A. Hard shorts will breach the 6.5 A limit, forcing the output into an immediate tristate latch-OFF. See Figure 5 and Figure 6. Output current limiting will cause junction temperatures to rise. A junction temperature above 160°C will cause the output current limit to progressively "fold-back" (or decrease) to 2.5 A typical at 175°C where thermal latch-OFF will occur. See Figure 7.

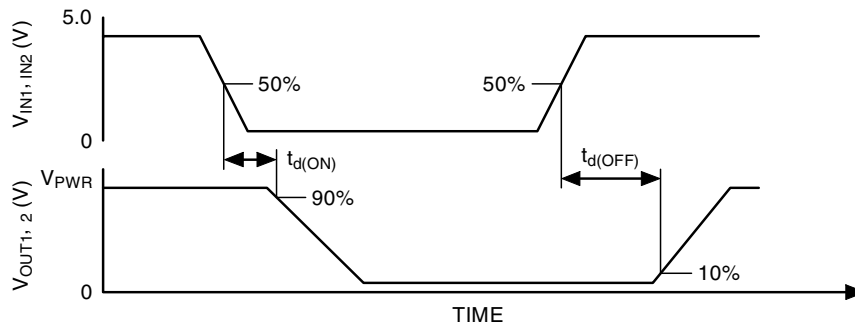

Figure 2. Output Delay Time

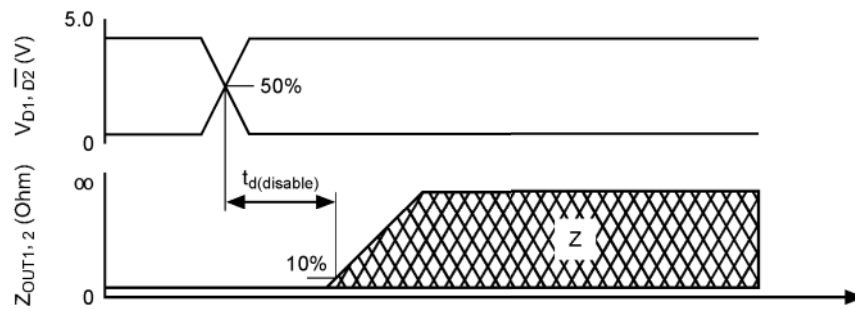

Figure 3. Disable Delay Time

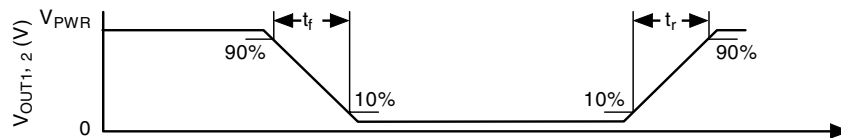
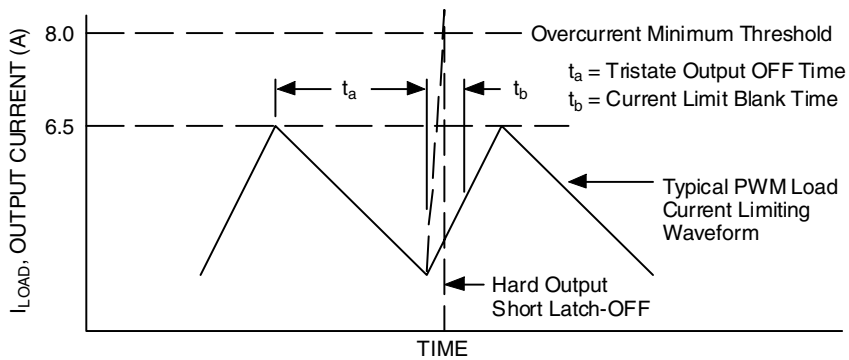
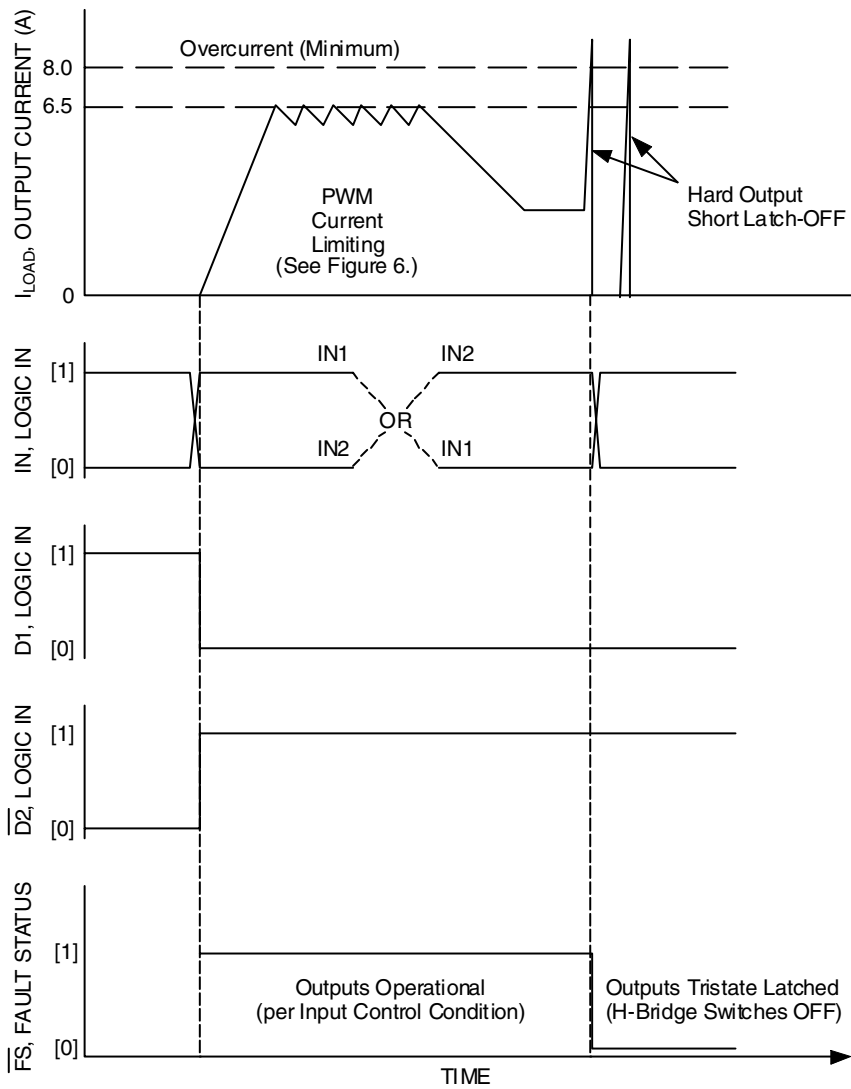

Figure 4. Output Switching Time



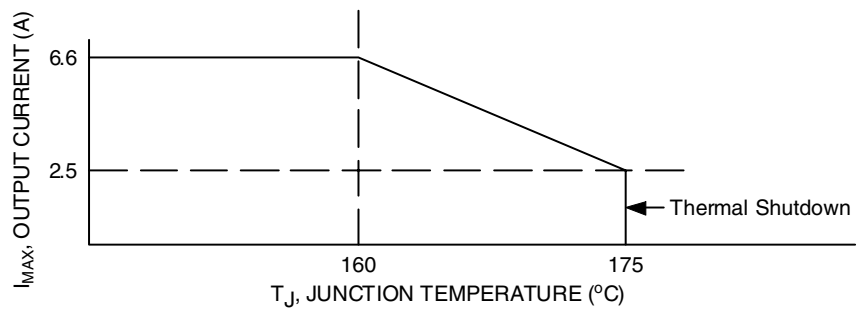

Figure 7. Maximum Output Current Limiting Versus Temperature

Table 1. Truth Table

The tristate conditions and the fault status are reset using D1 or $\overline{D2}$. The truth table uses the following notations: L = Low, H = High, X = High or Low, and Z = High impedance (all output power transistors are switched off).

Device State	Input Conditions				Status	Outputs	
	D1	$\overline{D2}$	IN1	IN2	\overline{FS}	OUT1	OUT2
Forward	L	H	H	L	H	H	L
Reverse	L	H	L	H	H	L	H
Free Wheeling Low	L	H	L	L	H	L	L
Free Wheeling High	L	H	H	H	H	H	H
Disable 1 (D1)	H	X	X	X	L	Z	Z
Disable 2 ($\overline{D2}$)	X	L	X	X	L	Z	Z
IN1 Disconnected	L	H	Z	X	H	H	X
IN2 Disconnected	L	H	X	Z	H	X	H
D1 Disconnected	Z	X	X	X	L	Z	Z
$\overline{D2}$ Disconnected	X	Z	X	X	L	Z	Z
Undervoltage (Note 27)	X	X	X	X	L	Z	Z
Overtemperature (Note 28)	X	X	X	X	L	Z	Z
Overcurrent (Note 28)	X	X	X	X	L	Z	Z

Notes:

27. In the case of an undervoltage condition, the outputs tristate and the fault status is SET logic LOW. Upon undervoltage recovery, fault status is reset automatically or automatically cleared and the outputs are restored to their original operating condition.
28. When an overcurrent or overtemperature condition is detected, the power outputs are tristate latched-OFF independent of the input signals and the fault status flag is SET logic LOW.

SYSTEM/APPLICATION INFORMATION

INTRODUCTION

Numerous protection and operational features (speed, torque, direction, dynamic braking, and PWM control), in addition to the 5.2 A output current capability, make the 33886 a very attractive cost-effective solution for controlling a broad range of fractional horsepower DC-motors. A pair of 33886 devices can be used to control bipolar stepper motors in both directions. In addition, the 33886 can be used to control permanent magnet solenoids in a push-pull variable force fashion using PWM control. The 33886 can also be used to excite transformer primary windings with a switched square wave to produce secondary winding AC currents.

As shown in Figure 1, Internal Block Diagram, the 33886 is a fully protected monolithic H-Bridge with Fault Status reporting. For a DC-motor to run the input conditions need be as follows: D1 input logic LOW, $\overline{D2}$ input logic HIGH, \overline{FS} flag cleared (logic HIGH), with one IN logic LOW and the other IN logic HIGH to define output polarity. The 33886 can execute Dynamic Braking by simultaneously turning-ON either the two High-Side or the two Low-Side H-Bridge switches; e.g., IN1 and IN2 logic HIGH or IN1 and IN2 logic LOW.

The 33886 outputs are capable of providing a continuous DC load current of 5.2 A from a 36 V V_{PWR} source. An internal charge pump supports PWM frequencies to 10 kHz. An external

pull-up resistor is required for the open drain \overline{FS} pin for fault status reporting.

Two independent inputs (IN1 and IN2) provide control of the two totem-pole half-bridge outputs. Two disable inputs (D1 and $\overline{D2}$) are for forcing the H-Bridge outputs to a high impedance state (all H-Bridge switches OFF).

The 33886 has Undervoltage Shutdown with automatic recovery, Output Current Limiting, Output Short-Circuit Latch-OFF, and Overtemperature Latch-OFF. An Undervoltage Shutdown, Output Short-Circuit Latch-OFF, or Overtemperature Latch-OFF fault condition will cause the outputs to turn-OFF (tristate) and the fault output flag to be set LOW. Either of the D inputs or V_{PWR} must be “toggled” to clear the fault flag. The Overcurrent/Overtemperature Shutdown scheme is unique and best described as using a junction temperature dependent output current “fold back” protection scheme. When an overcurrent condition is experienced, the current limited output is “ramped down” as the junction temperature increases above 160°C, until at 175°C the output current has decreased to about 2.5 A. Above 175°C, Overtemperature Shutdown (Latch-OFF) occurs. This feature allows the device to remain in operation for a longer time with unexpected loads, but with regressive output performance at junction temperatures above 160°C.

FUNCTIONAL PIN DESCRIPTION

PGND and AGND

Power and analog ground pins. The power and analog ground pins should be connected together with a very low impedance connection.

V_{PWR}

V_{PWR} pins are the power supply inputs to the device. All V_{PWR} pins must be connected together on the printed circuit board with as short as possible traces offering as low impedance as possible between pins.

V_{PWR} pins have an undervoltage threshold. If the supply voltage drops below a V_{PWR} undervoltage threshold, the output power stage switches to a tristate condition and the fault status flag is SET and the Fault Status pin voltage switched to a logic LOW. When the supply voltage returns to a level that is above the threshold, the power stage automatically resumes normal operation according to the established condition of the input pins and the fault status flag is automatically reset logic HIGH.

Fault Status (\overline{FS})

This pin is the device fault status output. This output is an active LOW open drain structure requiring a pull-up resistor to 5.0 V. Refer to Table 1, Truth Table.

IN1, IN2, D1, $\overline{D2}$

These pins are input control pins used to control the outputs. These pins are 5.0 V CMOS-compatible inputs with hysteresis. The IN1 and IN2 independently control OUT1 and OUT2, respectively. D1 and $\overline{D2}$ are complimentary inputs used to tristate disable the H-Bridge outputs.

When either D1 or $\overline{D2}$ is SET (D1 = logic HIGH or $\overline{D2}$ = logic LOW) in the disable state, outputs OUT1 and OUT2 are both tristate disabled; however, the rest of the device circuitry is fully operational and the supply $I_{PWR(standby)}$ current is reduced to a few milli-amperes. See Table 1, Truth Table, and STATIC ELECTRICAL CHARACTERISTICS table.

OUT1, OUT2

These pins are the outputs of the H-Bridge with integrated free-wheeling diodes. The bridge output is controlled using the IN1, IN2, D1, and $\overline{D2}$ inputs. The outputs have Pulse Width Modulated (PWM) current limiting above 6.5 A. The outputs also have thermal shutdown (tristate latch-OFF) with hysteresis as well as short circuit latch-OFF protection.

A disable timer (time t_b) incorporated to detect currents that are higher than current limit is activated at each output activation to facilitate detecting hard output short conditions. See Figure 6.

C_{CP}

Charge pump output pin. A filter capacitor (up to 33 nF) can be connected from the C_{CP} pin and PGND. The device can

operate without the external capacitor, although the C_{CP} capacitor helps to reduce noise and allows the device to perform at maximum speed, timing, and PWM frequency.

PERFORMANCE FEATURES

Short Circuit or Overcurrent Protection

If an output overcurrent condition is detected, the power outputs tristate latched-OFF independent of the input signal states and the fault status output flag is SET logic LOW. If the D1 voltage changes from logic HIGH to logic LOW or from logic LOW to logic HIGH on $\overline{D2}$, the output switches ON again and the fault status flag is reset (cleared) to a logic HIGH state.

The output stage will always switch into the mode defined by the input pins (IN1, IN2, D1, and $\overline{D2}$), provided the device junction temperature is within the specified operating temperature.

PWM Current Limiting

The maximum current flow under normal operating conditions is limited to I_{MAX} (5.2 to 7.8 A). When the maximum current value is reached, the output stages are tristated for a fixed time (t_a) of 20 μs typical. Depending on the time constant associated with the load characteristics, the output current decreases during the tristate duration until the next output ON cycle occurs. See Figure 6.

The PWM current limitation value is dependent upon the device junction temperature. When $-40^{\circ}\text{C} < T_J < 160^{\circ}\text{C}$, I_{MAX} is between 5.2 and 7.8 A. When T_J exceeds 160°C, the I_{MAX} current decreases linearly down to 2.5 A typical at 175°C typical (or where the device reaches T_{LIM}) and overtemperature shutdown occurs. See Figure 7. This feature allows the device to remain operational for a longer time but at a regressing output performance level at junction temperatures above 160°C.

Overtemperature Shutdown and Hysteresis

If an overtemperature condition occurs, the power outputs are tristate latched-OFF independent of the input signals and the fault status flag is SET logic LOW.

If the D1 voltage changes from logic HIGH to logic LOW or from logic LOW to logic HIGH on $\overline{D2}$, the output stage switches ON again, providing the temperature is below the overtemperature threshold limit minus the hysteresis. The fault status flag is reset (cleared) logic HIGH.

PACKAGE DIMENSIONS

DH SUFFIX
 (20-LEAD HSOP)
 PLASTIC PACKAGE
 CASE 979C-02
 ISSUE A

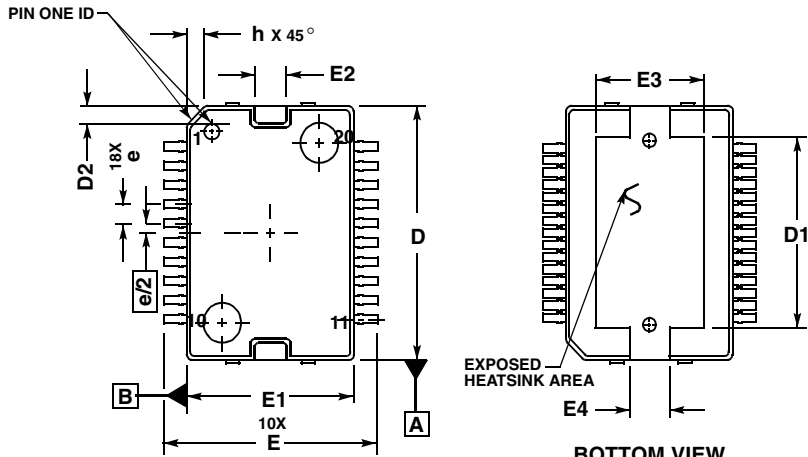

NOTES:

1. CONTROLLING DIMENSION: MILLIMETER.
2. DIMENSIONS AND TOLERANCES PER ASME Y14.5M, 1994.
3. DATUM PLANE -H- IS LOCATED AT BOTTOM OF LEAD AND IS COINCIDENT WITH THE LEAD WHERE THE LEAD EXITS THE PLASTIC BODY AT THE BOTTOM OF THE PARTING LINE.
4. DIMENSIONS D AND E1 DO NOT INCLUDE MOLD PROTRUSION. ALLOWABLE PROTRUSION IS 0.150 PER SIDE. DIMENSIONS D AND E1 DO INCLUDE MOLD MISMATCH AND ARE DETERMINED AT DATUM PLANE -H-.
5. DIMENSION b DOES NOT INCLUDE DAMBAR PROTRUSION. ALLOWABLE DAMBAR PROTRUSION SHALL BE 0.127 TOTAL IN EXCESS OF THE b DIMENSION AT MAXIMUM MATERIAL CONDITION.
6. DATUMS -A- AND -B- TO BE DETERMINED AT DATUM PLANE -H-.
7. DIMENSION D DOES NOT INCLUDE TIEBAR PROTRUSIONS. ALLOWABLE TIEBAR PROTRUSIONS ARE 0.150 PER SIDE.

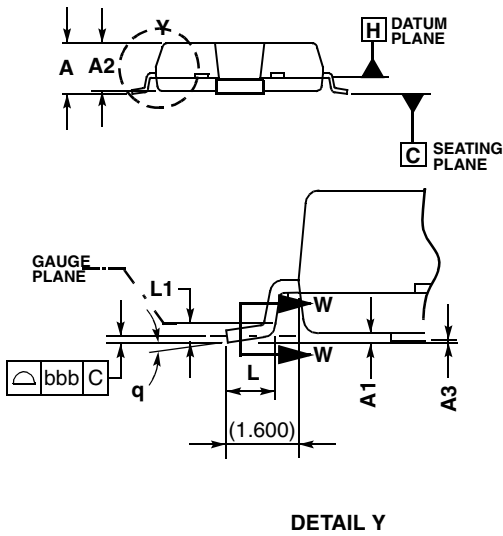

DIM	MILLIMETERS	
	MIN	MAX
A	3.000	3.400
A1	0.100	0.300
A2	2.900	3.100
A3	0.00	0.100
D	15.800	16.000
D1	11.700	12.600
D2	0.900	1.100
E	13.950	14.450
E1	10.900	11.100
E2	2.500	2.700
E3	6.400	7.200
E4	2.700	2.900
L	0.840	1.100
L1	0.350 BSC	
b	0.400	0.520
b1	0.400	0.482
c	0.230	0.320
c1	0.230	0.280
e	1.270 BSC	
h	---	1.100
q	0°	8°
aaa	0.200	
bbb	0.100	

NOTES

NOTES

Motorola reserves the right to make changes without further notice to any products herein. Motorola makes no warranty, representation or guarantee regarding the suitability of its products for any particular purpose, nor does Motorola assume any liability arising out of the application or use of any product or circuit, and specifically disclaims any and all liability, including without limitation consequential or incidental damages. "Typical" parameters can and do vary in different applications and actual performance may vary over time. All operating parameters, including "Typicals", must be validated for each customer application by customer's technical experts. Motorola does not convey any license under its patent rights nor the rights of others. Motorola products are not designed, intended, or authorized for use as components in systems intended for surgical implant into the body, or other applications intended to support or sustain life, or for any other application in which the failure of the Motorola product could create a situation where personal injury or death may occur. Should Buyer purchase or use Motorola products for any such unintended or unauthorized application, Buyer shall indemnify and hold Motorola and its officers, employees, subsidiaries, affiliates, and distributors harmless against all claims, costs, damages, and expenses, and reasonable attorney fees arising out of, directly or indirectly, any claim of personal injury or death associated with such unintended or unauthorized use, even if such claim alleges that Motorola was negligent regarding the design or manufacture of the part. Motorola and are registered trademarks of Motorola, Inc. Motorola, Inc. is an Equal Opportunity/Affirmative Action Employer.

MOTOROLA and the Stylized M Logo are registered in the US Patent and Trademark Office. All other product or service names are the property of their respective owners.

© Motorola, Inc. 2002

HOW TO REACH US:

USA/EUROPE/LOCATIONS NOT LISTED: Motorola Literature Distribution: P.O. Box 5405, Denver, Colorado 80217.

1-303-675-2140 or 1-800-441-2447

JAPAN: Motorola Japan Ltd.; SPS, Technical Information Center, 3-20-1 Minami-Azabu. Minato-ku, Tokyo 106-8573 Japan.

81-3-3440-3569

ASIA/PACIFIC: Motorola Semiconductors H.K. Ltd.; Silicon Harbour Centre, 2 Dai King Street, Tai Po Industrial Estate, Tao Po, N.T.,

Hong Kong. 852-26668334

TECHNICAL INFORMATION CENTER: 1-800-521-6274



MOTOROLA