



Features

- 19,999/1,999 counts dual LCD display
- Current consumption: Typ. 25mA @ 100kHz
- QFP-100L package for ES51919
- SSOP-48L package for ES51920
- 4-wire terminal with guarding measurement
- AutoLCR smart check and measurement
- Series/Parallel modes are selectable
- Ls/Lp/Cs/Cp with D/Q/θ/ESR parameters
- Open/Short calibration for AC impedance measurement is allowed:
Open condition requirement: Impedance is larger than $9.5M\Omega$ @ 1kHz
Short condition requirement: Impedance is less than 1.1Ω
- Support DCR mode $200.00\Omega \sim 200.0M\Omega$
- Five different test frequency are available:
100/120/1k/10k/100k Hz
- Test ac signal level: $0.6mV_{RMS}$ typ.
- 6 range resistor range used
- Test range:
L: $20.000 \mu H \sim 2000 H$
C: $200.00 pF \sim 20.00 mF$
R: $20.000 \Omega \sim 200.0 M\Omega$
- Multi-level battery voltage detector
- Support Backlight & Buzzer sound driver
- Source resistance depends on range
Min: 120Ω typical
Max: $1M\Omega$ typical

Application

Handheld LCR bridge meter

Description

The chipset of ES51919/ES51920 is suitable for LCR bridge application. By using ES51919/ES51920 to implement the LCR bridge meter, the complicated PCB design is not necessary. The ES51920 is the analog front end chip with resistor switches network to provide different ranges control. It also provides a high performance integrated circuit by the signal with different frequency to measure the complex impedance of the DUT by 5-terminals architecture. The ES51919 is the mix-mode processing chip to handle the calculation of the D/Q/ESR/θ parameter with Ls/Lp/Cs/Cp values. It also provides the user interface and LCD drivers to support dual display operation. Tolerance mode and relative mode are including in the dual display operation. A multiple-level battery detection and auto power-off scheme are built-in to help the improvement of battery life. The high performance of 4.5digits ADC circuit design is implemented in the ES51919/ES51920 chipset. A fully smart measurement for L/C/R is possible. User could measure the DUT impedance simply without change function key at the AUTOLCR smart mode



Introduction

The ES51919/ES51920 chipset is a total solution for high accuracy LCR meter which could measure Inductance/Capacitance/Resistance with secondary parameters including dissipation factor(D), quality factor(Q), phase angle(θ), equivalent series/parallel resistance(ESR or R_p). The chipset is fully auto ranging operation for AC impedance & DC resistance measurement. Because of high integrated circuit design, a smart measurement for L/C/R is possible (AUTOLCR mode). It means the user could measure the L/C/R components directly at AUTOLCR smart mode without changing the function key. User could also select the target test frequencies of 100Hz/120Hz/1kHz/10kHz/100kHz depending on DUT type. Components could be measured in series or parallel mode according to the DUT impedance automatically.

The LCR chipset built-in a 4.5 digits ADC operates at 1.2/s updating rate nominally for L/C/R mode. The chipset operates at 0.5/s updating rate for DCR mode.

The general DMM could measure DC resistance only, but the LCR meter could measure DC resistance and AC impedance. The impedance consists of resistance (real part) and reactance (imaginary part). For example, Z_s represents the impedance in series mode. Z_s can be defined a combination of resistance R_s and reactance X_s . It also could be defined as a $|Z|$ of magnitude with a phase angle θ .

Imaginary axis (series mode)

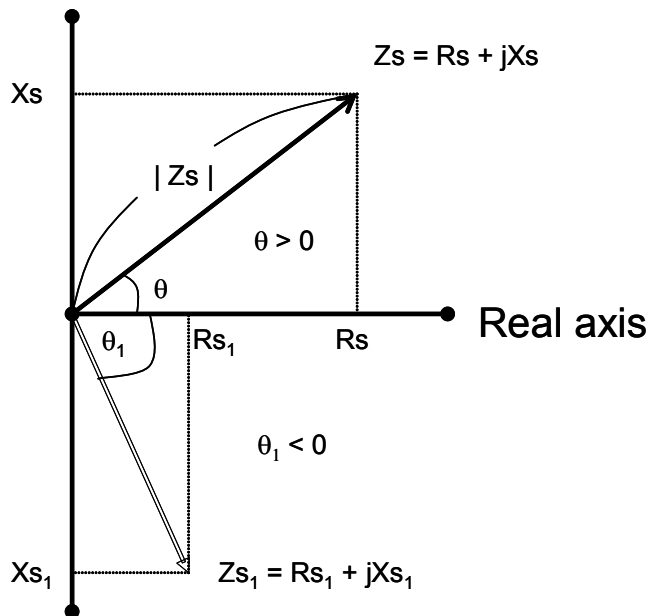

$$Z_s = R_s + jX_s \text{ or } |Z_s| \angle \theta$$

$$|Z| = \sqrt{R_s^2 + X_s^2}$$

$$R_s = |Z_s| \cos\theta$$

$$X_s = |Z_s| \sin\theta$$

$$X_s/R_s = \tan\theta$$

$$\theta = \tan^{-1}(X_s/R_s)$$

If $\theta > 0$, the reactance is inductive. In other words, if $\theta < 0$, the reactance is capacitive.

There are two types for reactance. The one is the inductive reactance X_L and the other is the capacitive reactance X_C . They could be defined as: (f = signal frequency)

$$X_L = 2\pi fL \quad (L = \text{Inductance})$$

$$X_C = \frac{1}{2\pi fC} \quad (C = \text{Capacitance})$$

Measurement mode

The impedance could be measured in series or parallel mode. The impedance Z in parallel mode could be represented as reciprocal of admittance Y . The admittance could be defined as $Y = G + jB$. The G is the conductance and the B is the susceptance.

Impedance in serial mode

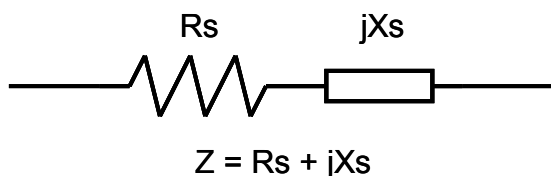

R_s : Resistance in series mode

X_s : Reactance in series mode

C_s : Capacitance in series mode

L_s : Inductance in series mode

Admittance in parallel mode

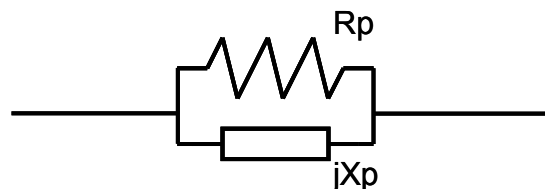

$$Y = 1/Z = 1/R_p + 1/jX_p = G + jB$$

R_p : Resistance in parallel mode

X_p : Reactance in parallel mode

C_p : Capacitance in parallel mode

L_p : Inductance in parallel mode

There are two factors to provide the ratio of real part and imaginary part. Usually the quality factor Q is used for inductance measurement and the dissipation factor D is used for capacitance measurement. D factor is defined as a reciprocal of Q factor.

$$Q = 1/D = \tan\theta$$

$$Q = X_s / R_s = 2\pi fL_s / R_s = 1 / 2\pi fC_s R_s$$

$$Q = B / G = R_p / |X_p| = R_p / 2\pi fL_p = 2\pi fC_p R_p$$



Actually, R_s and R_p are existed in the equivalent circuit of capacitor or inductor. If the capacitor is small, R_p is more important than R_s . If capacitor is large, the R_s is more important also. Therefore, use parallel mode to measure lower value capacitor and use series mode to measure higher value capacitor. For inductor, the impedance relationship is different from capacitor. If the inductor is small, R_p is almost no effect. If inductor is large, the R_s is no effect also. Therefore, use series mode to measure lower value inductor and use parallel mode to measure higher value inductor.

Open/short calibration

The ES51919/ES51920 chipset provides the open/short calibration process to get the better accuracy for high/low impedance measurement. The purpose of open/short calibration is to reduce the parasitic effect of the test fixture.

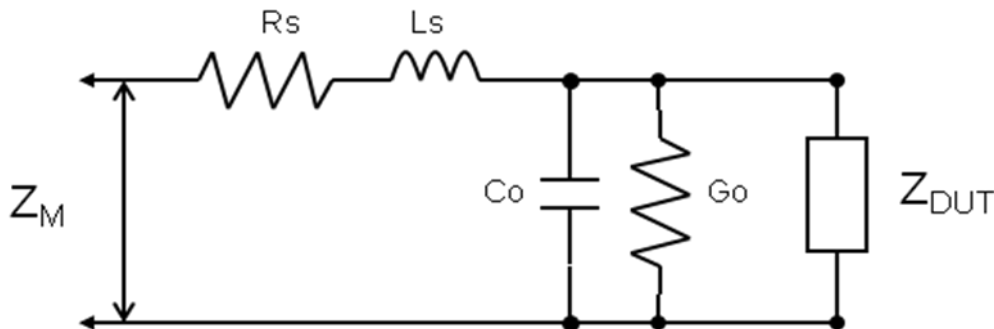

Z_M is defined as total impedance measured to DUT by the special test fixture which has some parasitic impedance. $Z_M = (R_s + j\omega L_s) + \left(\frac{1}{G_o + j\omega C_o} \parallel Z_{DUT} \right)$

Z_{OUT} is the target impedance user wants to realize. It is necessary to use the open/short calibration process to cancel the effect of $R_s + j\omega L_s$ and $G_o + j\omega C_o$.



Equivalent circuit

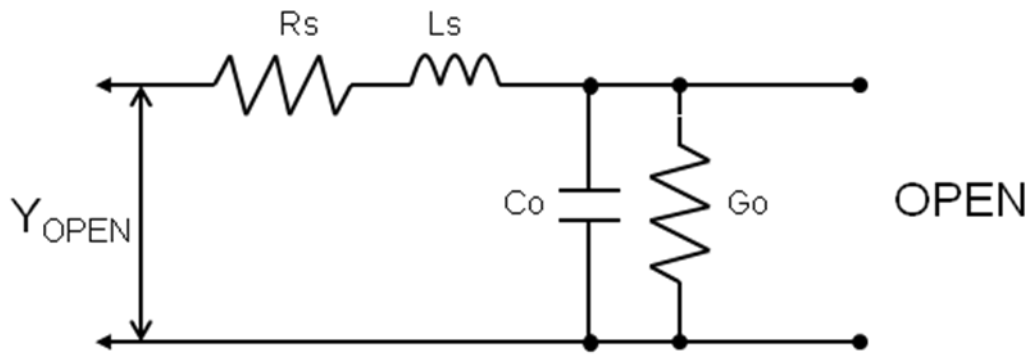
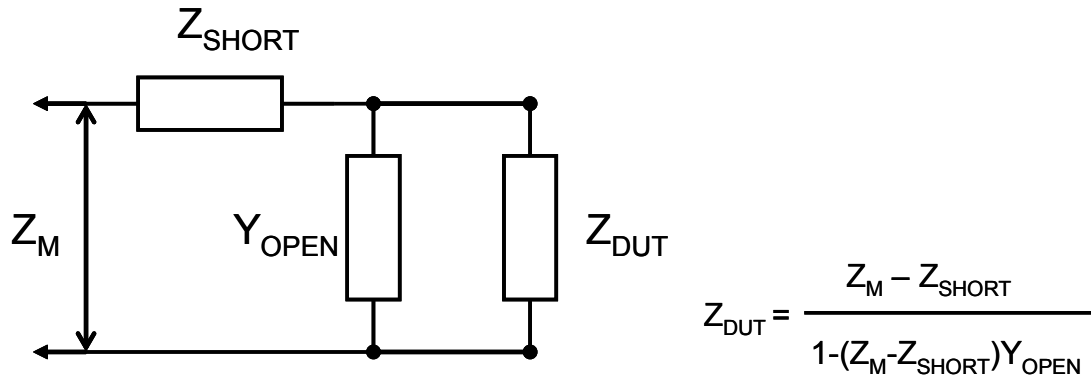

If $R_s + j\omega L_s \ll 1 / (G_o + j\omega C_o)$

$$Y_{OPEN} = G_o + j\omega C_o$$

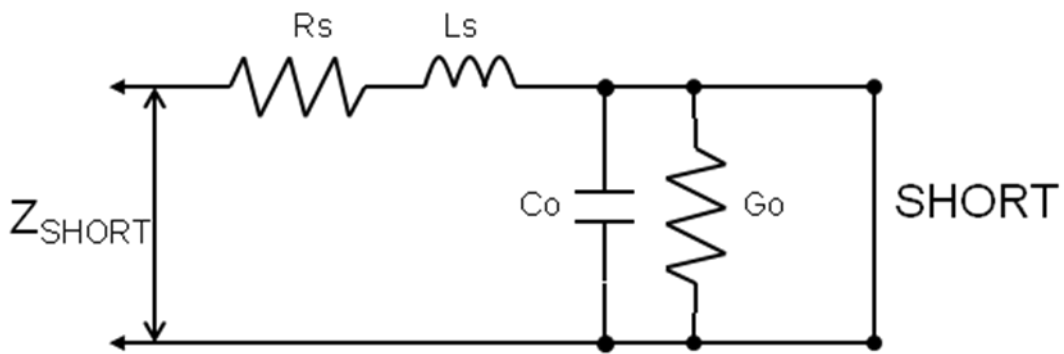

$$Z_{SHORT} = R_s + j\omega L_s$$

Resistance display range

Function	Frequency	Scale Range	Resolution
R _S /R _P	100Hz/120Hz	200.00Ω	0.01Ω
	100Hz/120Hz	2.0000kΩ	0.1Ω
	100Hz/120Hz	20.000kΩ	1Ω
	100Hz/120Hz	200.00kΩ	0.01kΩ
	100Hz/120Hz	2.0000MΩ	0.1kΩ
	100Hz/120Hz	20.000MΩ	1kΩ
	100Hz/120Hz	200.0MΩ	0.1MΩ
	1kHz	20.000Ω	1mΩ
	1kHz	200.00Ω	0.01Ω
	1kHz	2.0000kΩ	0.1Ω
	1kHz	20.000kΩ	1Ω
	1kHz	200.00kΩ	0.01kΩ
	1kHz	2.0000MΩ	0.1kΩ
	1kHz	20.000MΩ	1kΩ
	1kHz	200.0MΩ	0.1MΩ
	10kHz	20.000Ω	1mΩ
	10kHz	200.00Ω	0.01Ω
	10kHz	2.0000kΩ	0.1Ω
	10kHz	20.000kΩ	1Ω
	10kHz	200.00kΩ	0.01kΩ
	10kHz	2.0000MΩ	0.1kΩ
	10kHz	20.00MΩ	0.01MΩ
	100kHz	20.000Ω	1mΩ
	100kHz	200.00Ω	0.01Ω
	100kHz	2.0000kΩ	0.1Ω
	100kHz	20.000kΩ	1Ω
	100kHz	200.00kΩ	0.01kΩ
	100kHz	2.000MΩ	1kΩ

DC resistance display range

Function	Scale Range	Resolution
DCR	200.00Ω	0.01Ω
	2.0000kΩ	0.1Ω
	20.000kΩ	1Ω
	200.00kΩ	0.01kΩ
	2.0000MΩ	0.1kΩ
	20.000MΩ	1kΩ
	200.0MΩ	0.1MΩ

Capacitance display range

Function	Frequency	Scale Range	Resolution
C _S /C _P	100Hz/120Hz	20.000nF ¹	1pF
	100Hz/120Hz	200.00nF	0.01nF
	100Hz/120Hz	2000.0nF	0.1nF
	100Hz/120Hz	20.000uF	1nF
	100Hz/120Hz	200.00uF	0.01uF
	100Hz/120Hz	2000.0uF	0.1uF
	100Hz/120Hz	20.00mF	0.01mF
	1kHz	2000.0pF	0.1pF
	1kHz	20.000nF	1pF
	1kHz	200.00nF	0.01nF
	1kHz	2000.0nF	0.1nF
	1kHz	20.000uF	1nF
	1kHz	200.00uF	0.01uF
	1kHz	2000uF	1uF
	10kHz	200.00pF	0.01pF
	10kHz	2000.0pF	0.1pF
	10kHz	20.000nF	1pF
	10kHz	200.00nF	0.01nF
	10kHz	2000.0nF	0.1nF
	10kHz	20.000uF	1nF
	10kHz	200.0uF	0.1uF
	100kHz	200.00pF	0.01pF
	100kHz	2000.0pF	0.1pF
	100kHz	20.000nF	1pF
	100kHz	200.00nF	0.01nF
	100kHz	2000.0nF	0.1nF
100kHz	20.00uF	0.01uF	

¹If the counts of LCD display are less than 2000, the unit will be “pF”.



Inductance display range

Function	Frequency	Scale Range	Resolution
L _S /L _P	100Hz/120Hz	20.000mH ²	1uH
	100Hz/120Hz	200.00mH	0.01mH
	100Hz/120Hz	2000.0mH	0.1mH
	100Hz/120Hz	20.000H	1mH
	100Hz/120Hz	200.00H	0.01H
	100Hz/120Hz	2000.0H	0.1H
	100Hz/120Hz	20.000kH	0.001kH
	1kHz	2000.0uH	0.1uH
	1kHz	20.000mH	1uH
	1kHz	200.00mH	0.01mH
	1kHz	2000.0mH	0.1mH
	1kHz	20.000H	1mH
	1kHz	200.00H	0.01H
	1kHz	2000.0H	0.1H
	10kHz	200.00uH	0.01uH
	10kHz	2000.0uH	0.1uH
	10kHz	20.000mH	1uH
	10kHz	200.00mH	0.01mH
	10kHz	2000.0mH	0.1mH
	10kHz	20.000H	1mH
	100kHz	20.000uH	0.001uH
	100kHz	200.00uH	0.01uH
	100kHz	2000.0uH	0.1uH
	100kHz	20.000mH	1uH
	100kHz	200.00mH	0.01mH

²If the counts of LCD display are less than 2000, the unit will be “uH”.

Accuracy (Ae) vs. Impedance (Z_{DUT}) @ Ta =18 ~ 28 °C

Freq. / Z	0.1- 1Ω	1 – 10Ω	10 – 100kΩ	100k – 1MΩ	1M – 20MΩ	20M– 200MΩ	Remark
DCR	1.0%+5d	0.5%+3d	0.3%+2d	0.5%+3d	1.0%+5d	2.0%+5d	D < 0.1
100/120Hz	1.0%+5d	0.5%+3d	0.3%+2d	0.5%+3d	1.0%+5d	2.0%+5d	
1kHz	1.0%+5d	0.5%+3d	0.3%+2d	0.5%+3d	1.0%+5d	5.0%+5d	
10kHz	1.0%+5d	0.5%+3d	0.3%+2d	0.5%+3d	2.0%+5d	N/A	
100kHz	2.0%+5d	1.0%+5d	0.5%+3d	1.0%+5d	2.0%+5d (1M – 2MΩ)		

Note: All accuracy is guaranteed by proper ratio resistor calibration and open/short calibration. All accuracy is guaranteed for 10cm distance from VDUTH/VDUTL pins of ES51920.

If $D > 0.1$, the accuracy should be multiplied by $\sqrt{1 + D^2}$

$Z_C = 1/2 \pi f C$ if $D \ll 0.1$ in capacitance mode

$Z_L = 2 \pi f L$ if $D \ll 0.1$ in inductance mode

Sub-display parameters accuracy

Ae = impedance (Z) accuracy

Definition: $Q = 1/D$

$$R_p = \text{ESR (or } R_s) \times (1 + 1/D^2)$$

1. D value accuracy $D_e = \pm A_e \times (1+D)$

2. ESR accuracy $R_e = \pm Z_M \times A_e (\Omega)$

ie., $Z_M =$ impedance calculated by $1/2\pi f C$ or $2 \pi f L$

3. Phase angle θ accuracy $\theta_e = \pm (180/\pi) \times A_e (\text{deg})$

4-terminals measurement with guard shielding

The DUT test leads are implemented by four terminals measurement. For achieve the accuracy shown above, it is necessary to do open/short calibration process before measurement. The test leads for DUT should be as short as possible. If long extended cable is used, the guard shielding is necessary.



ES51920 Package information (SSOP-48L)

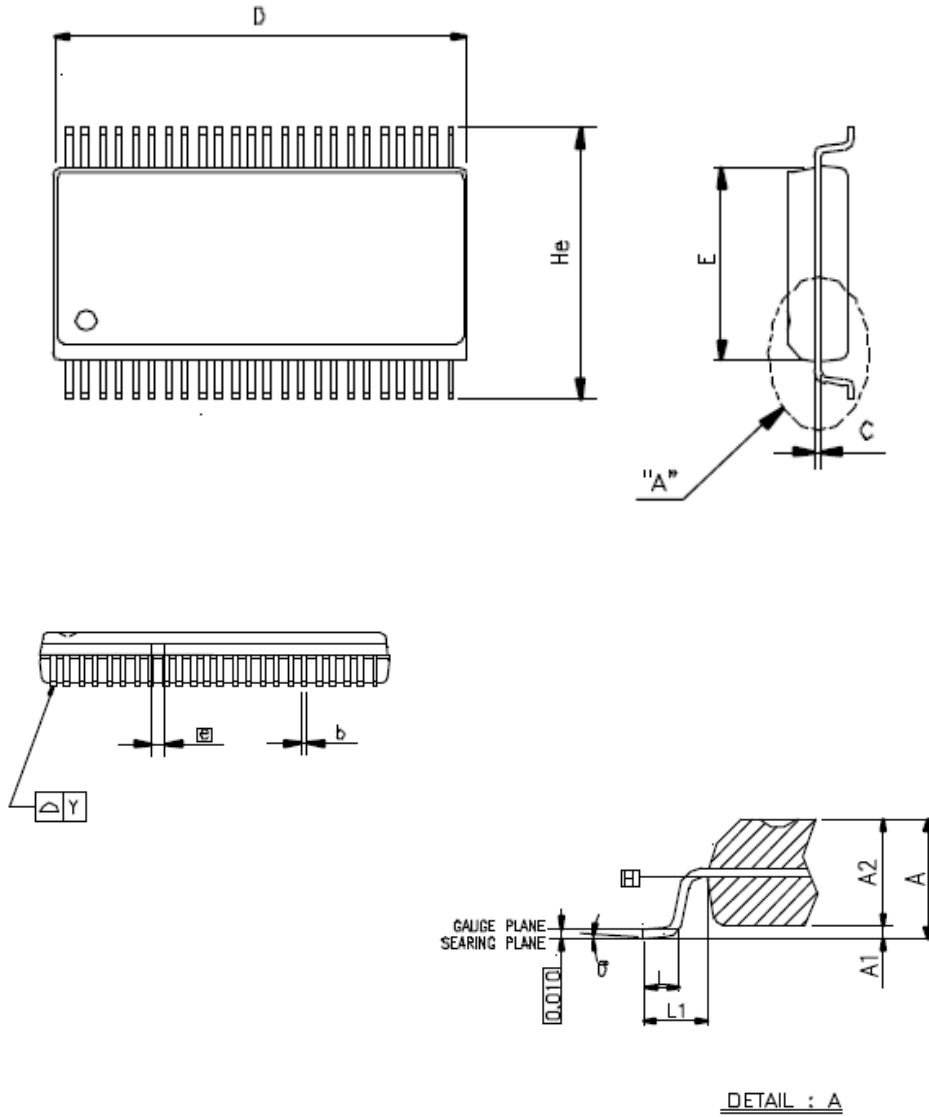

SYMBOLS	MIN.	NOM.	MAX.
A	0.095	0.102	0.110
A1	0.008	0.012	0.016
A2	0.089	0.094	0.099
b	0.008	0.010	0.013
c	—	0.008	—
D	0.620	0.625	0.630
E	0.291	0.295	0.299
Ⓜ	—	0.025	—
He	0.396	0.406	0.416
L	0.020	0.030	0.040
L1	—	0.056	—
Y	—	—	0.003
θ°	0°	—	8°

UNIT : INCH

NOTES:

- DATUM PLANE Ⓜ IS LOCATED AT THE BOTTOM OF THE MOLD PARTING LINE COINCIDENT WITH WHERE THE LEAD EXITS THE BODY.
- DIMENSIONS E AND D DO NOT INCLUDE MOLD PROTRUSION. ALLOWABLE PROTRUSION IS 6 MIL PER SIDE. DIMENSIONS E AND D DO INCLUDE MOLD MISMATCH AND ARE DETERMINED AT DATUM PLANE Ⓜ
- DIMENSION b DOES NOT INCLUDE DAMBAR PROTRUSION.



ES51919 Package information (QFP-100L)

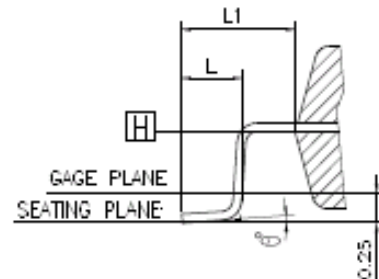
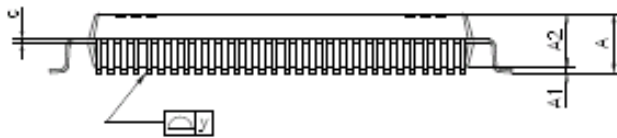
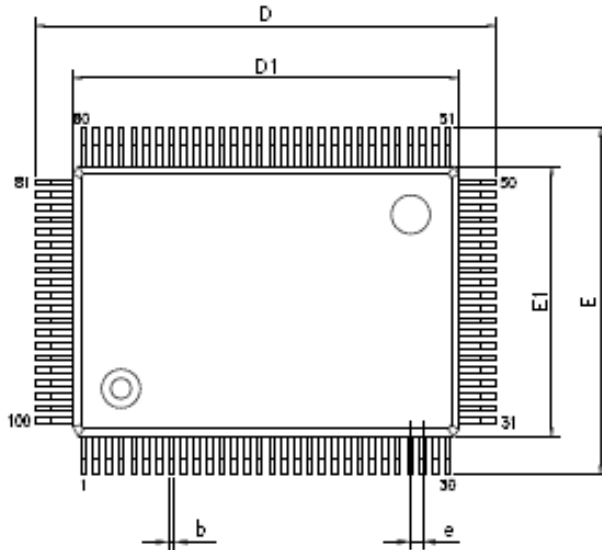

SYMBOLS	MIN.	NOM	MAX.
A	-	-	-
A1	0.25	-	0.50
A2	2.50	-	2.90
b	0.20	0.30	0.40
c	0.10	0.15	0.20
D	24.60	24.80	25.00
D1	19.90	20.00	20.10
e	0.498	0.65	0.802
E	18.60	18.80	19.00
E1	13.90	14.00	14.10
L	1.00	1.20	1.40
L1	-	2.40	-
θ	0	-	7
y	-	-	0.10

UNIT : mm

NOTES:

1. JEDEC OUTLINE: MO-112 CC-1
2. DATUM PLANE [H] IS LOCATED AT THE BOTTOM OF THE MOLD PARTING LINE COINCIDENT WITH WHERE THE LEAD EXITS THE BODY.
3. DIMENSIONS D1 AND E1 DO NOT INCLUDE MOLD PROTRUSION. ALLOWABLE PROTRUSION IS 0.25 mm PER SIDE. DIMENSIONS D1 AND E1 DO INCLUDE MOLD MISMATCH AND ARE DETERMINED AT DATUM PLANE [H].
4. DIMENSION b DOES NOT INCLUDE DAMBAR PROTRUSION.