

To all our customers

Regarding the change of names mentioned in the document, such as Mitsubishi Electric and Mitsubishi XX, to Renesas Technology Corp.

The semiconductor operations of Hitachi and Mitsubishi Electric were transferred to Renesas Technology Corporation on April 1st 2003. These operations include microcomputer, logic, analog and discrete devices, and memory chips other than DRAMs (flash memory, SRAMs etc.) Accordingly, although Mitsubishi Electric, Mitsubishi Electric Corporation, Mitsubishi Semiconductors, and other Mitsubishi brand names are mentioned in the document, these names have in fact all been changed to Renesas Technology Corp. Thank you for your understanding. Except for our corporate trademark, logo and corporate statement, no changes whatsoever have been made to the contents of the document, and these changes do not constitute any alteration to the contents of the document itself.

Note : Mitsubishi Electric will continue the business operations of high frequency & optical devices and power devices.

Renesas Technology Corp.
Customer Support Dept.
April 1, 2003

MITSUBISHI SEMICONDUCTORS
M63020FP
SPINDLE MOTOR AND 5CH ACTUATOR DRIVER

This IC is 1 chip driver IC for spindle motor and 5 channel actuators. All of the motor and actuator of optical disk drive system (CD-ROM etc.) can be driven by only this IC. This IC has a direct PWM control system for Spindle and Slide channels drive due to reducing IC power dissipation. This IC has three voltage supply terminals (for Spindle, Slide, Focus/Tracking and Loading), and three voltage supply can be set separately. Further more this IC has short braking select function, FG amplifier, thermal shut down circuit, standby circuit, reverse rotation detect circuit.

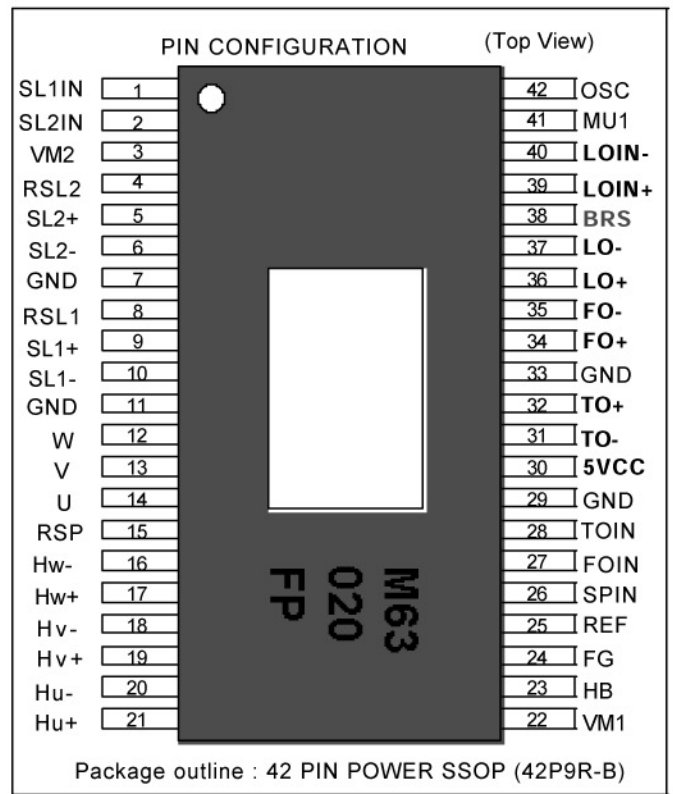

<APPLICATION>

CD-ROM, DVD, DVD-ROM, DVD-RAM ,Optical disc related system,etc

<BLOCK DIAGRAM>

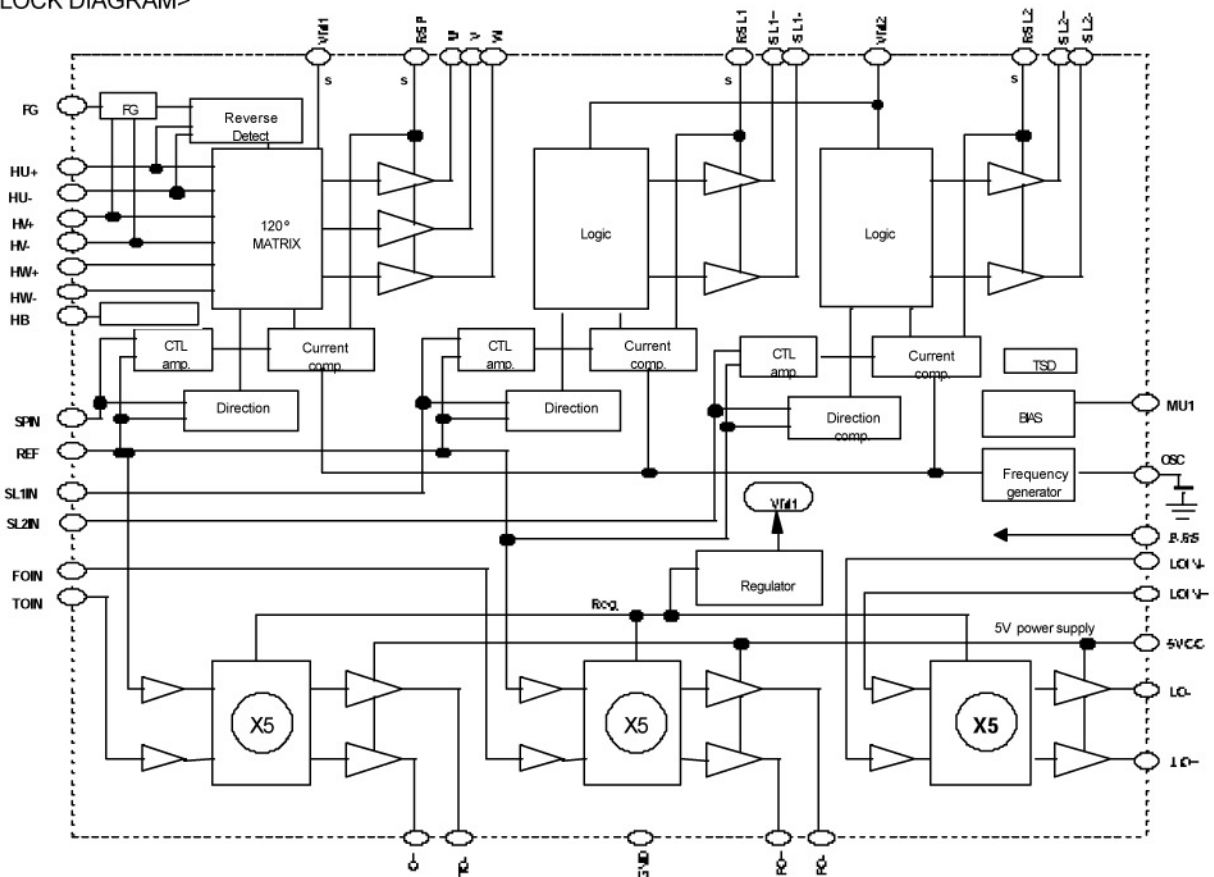

MITSUBISHI SEMICONDUCTORS
M63020FP
SPINDLE MOTOR AND 5CH ACTUATOR DRIVER

<PIN FUNCTION>

TERMINAL	SYMBOL	TERMINAL FUNCTION	TERMINAL	SYMBOL	TERMINAL FUNCTION
1	SL1IN	Slide control voltage input 1	42	OSC	PWM carrier oscillation set
2	SL2IN	Slide control voltage input 2	41	MU1	mute 1
3	VM2	Motor Power Supply 3(for Slide)	40	LOIN-	Loading control input(-)
4	RSL2	Slide current sense 2	39	LOIN+	Loading control input(+)
5	SL2+	Slide non-inverted output 2	38	BRS	Brake select control terminal
6	SL2-	Slide inverted output 2	37	LO-	Loading inverted output
7	GND	GND	36	LO+	Loading non-inverted output
8	RSL1	Slide current sense 1	35	FO-	Focus inverted output
9	SL1+	Slide non-inverted output 1	34	FO+	Focus non-inverted output
10	SL1-	Slide inverted output 1	33	GND	GND
11	GND	GND	32	TO+	Tracking non-inverted output
12	W	Motor drive output W	31	TO-	Tracking inverted output
13	V	Motor drive output V	30	5VCC	5V Power Supply(for FS ,TS,LO)
14	U	Motor drive output U	29	GND	GND
15	RSP	Spindle current sense	28	TOIN	Tracking control voltage input
16	HW-	HW- sensor amp. input	27	FOIN	Focus control voltage input
17	HW+	HW+ sensor amp. input	26	SPIN	Spindle control voltage input
18	HV-	HV- sensor amp. input	25	REF	Reference voltage input
19	HV+	HV+ sensor amp. input	24	FG	Frequency generator output
20	HU-	HU- sensor amp. input	23	HB	Bias for Hall Sensor
21	HU+	HU+ sensor amp. input	22	VM1	Motor Power Supply 1(for Spindle)

MITSUBISHI SEMICONDUCTORS
M63020FP
SPINDLE MOTOR AND 5CH ACTUATOR DRIVER

<ABSOLUTE MAXIMUM RATING> (Ta=25°C)

SYMBOL	PARAMETER	CONDITIONS	RATING	Unit
5VCC	5V power supply	Focus,Tracking and Loading power supply	7	V
VM1	Motor power supply 1	Spindle power supply	15	V
VM2	Motor power supply 2	Slide power supply	15	V
IoA	Motor Output Current A	Focus,Tracking and Loading output current	1.0	A
IoB	Motor Output Current B	Spindle and Slide output current *note 1	1.2	A
Vin	Maximum input voltage of terminals	MU1,Hw-,Hw+,Hv,Hv+,Hu-,Hu+,REF,SPIN,BRS TOIN,FOIN,OSC,SLIN1,SLIN2,LOIN-,LOIN+	0 ~ 5VCC	V
Pt	Power dissipation	Free Air and on the grass epoxy board	2.6	W
Kθ	Thermal derating	Free Air and on the grass epoxy board	20.8	mW / °C
Tj	Junction temperature		150	°C
Topr	Operating temperature		-20 ~ +75	°C
Tstg	Storage temperature		-40 ~ +150	°C

*note1 ; The ICs must be operated within the Pt (power dissipation) or the area of safety operation

The spindle and slide output terminal is needed external shottky diode between each output and GND when it is used above 0.6A. Discription(IoA) is case of with external shottky diode.

<RECOMMENDED OPERATING CONDITIONS> (Ta=25°C)

SYMBOL	PARAMETER	LIMITS			Unit
		minimum	typical	maximum	
VM1	VM1 power supply(for Spindle)	6	12	13.2	V
VM2	VM2 power supply(for Slide)	4.5	12	13.2	V
5VCC	5V power supply(for FS,TS,LO)	4.5	5	7	V
IoA	Spindle and Slide Output Current *note 2	—	0.5	1.0	A
IoB	Focus, Tracking and Loading Output Current	—	0.5	0.8	A
Fosc	PWM carrier frequency	30	—	120	KHz

*note2

The spindle and slide output terminal is needed external shottky diode between each output and GND when it is used above 0.6A. Discription(IoA) is case of with external shottky diode.

mitsubishi semiconductors
M6302FP
SPINDLE MOTOR AND 5CH ACTUATOR DRIVER

<THERMAL DERATING>

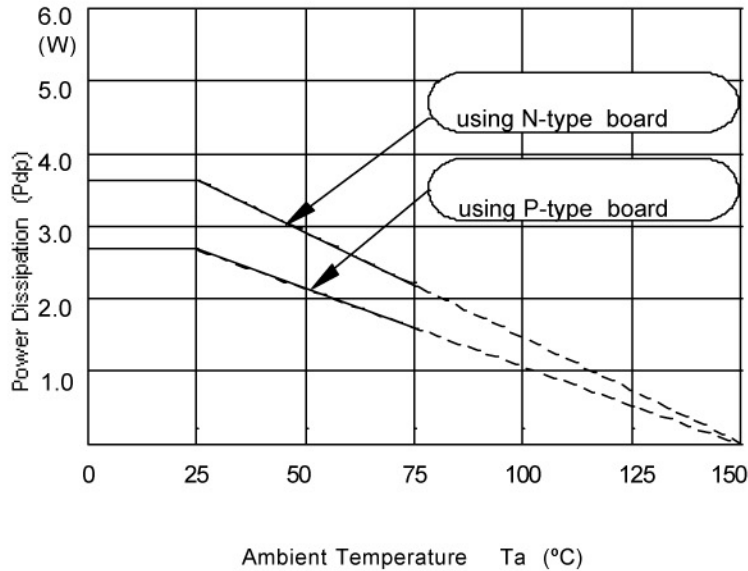

This IC's package is POWER-SSOP, so improving the board on which the IC is mounted enables a large power dissipation without a heat sink.

For example, using an 1 layer glass epoxy resin board, the IC's power dissipation is 2.6W at least. And it comes to 3.6W by using an improved 2 layer board.

The information of the N, P type board is shown in attached.

<ELECTRICAL CHARACTERISTICS>

Common

(Ta=25°C, 5VCC=5V, VM1=VM2=12V unless otherwise noted.)

SYMBOL	PARAMETER	CONDITIONS	LIMITS			Unit
			MIN	TYP	MAX	
Icc1	Supply current	5VCC, VM1, VM2 current MU1=5V	—	60	78	mA
Icc2	Sleep current	5VCC, VM1, VM2 current under Sleep (MU1 = 0V).	—	0	30	□A
Fosc	PWM carrier frequency	OSC : with 330pF	—	65	—	KHz
VinREF	REF input voltage range		1.0	—	3.3	V
IinREF	REF input voltage range	VREF=1.65V	-10	—	+10	□A
VMULO	MUTE terminal low voltage	MU1	—	—	0.8	V
VMUHI	MUTE terminal high voltage	MU1	3.0	—	—	V
IMU	Mute terminal input current	MU1 at 5V input voltage	—	—	500	□A
BRSL0	BRS terminal low voltage	BRS	—	—	0.8	V
BRSHI	BRS terminal high voltage	BRS	3.0	—	—	V
IBRS	BRS terminal input current	BRS at 5V input voltage	—	—	430	□A

mitsubishi semiconductors
M63020FP
SPINDLE MOTOR AND 5CH ACTUATOR DRIVER

<ELECTRICAL CHARACTERISTICS>

Spindle

(Ta=25°C, 5VCC=5V, VM1=VM2=12V unless otherwise noted.)

SYMBOL	PARAMETER	CONDITIONS	LIMITS			Unit
			MIN	TYP	MAX	
Vdyc1	Dynamic range of output	Io=0.5 [A]	10.3	10.8	—	V
Vdead1-	Control voltage dead zone 1	SPIN<REF [REVERSE]	-80	-40	0	mV
Vdead1+		REF<SPIN [FORWARD]	0	+40	+80	mV
Vin1	Control voltage input range 1	SPIN	0	—	5	V
Gvo1	Control gain 1	Gio1=Gvo1/ Rs [A/V]	0.85	1.0	1.15	V/V
Vlim1F	Control limit 1F	Ilim1F=Vlim1F/ Rs [A]	0.4	0.5	0.6	V
Vlim1R	Control limit 1R	Ilim1R=Vlim1R/ Rs [A]	0.22	0.28	0.34	V
VHcom	Hall sensor amp. common mode input range	Hu+,Hu-,Hv+,Hv-,Hw+,Hw-	1.3	—	3.7	V
VHmin	Hall sensor amp. input signal level	Hu+,Hu-,Hv+,Hv-,Hw+,Hw-	60	—	—	mVp-p
VHB	HB output voltage	at Load current (IHB)=10mA	0.6	0.85	1.2	V
IHB	HB terminal sink current	MU1=5V	—	—	30	mA

Slide 1,2

(Ta=25°C, 5VCC=5V, VM1=VM2=12V unless otherwise noted.)

SYMBOL	PARAMETER	CONDITIONS	LIMITS			Unit
			MIN	TYP	MAX	
Vdyc2	Dynamic range of output	Io=0.5 [A] at VM2=5[V]	3.3	3.8	—	V
		at VM2=12[V]	10.3	10.8	—	
Vdead2-	Control voltage dead zone 2	SL1IN,SI2IN < REF	-80	-30	0	mV
Vdead2+		REF < SL1IN ,SL2IN	0	+30	+80	mV
Vin2	Control voltage input range 2	SL1IN,SL2IN	0	—	5	V
Gvo2	Control gain 2	Gio2=Gvo2/ Rs [A/V]	0.85	1.0	1.15	V/V
Vlim2	Control limit 2	Ilim2=Vlim2/ Rs [A]	0.43	0.5	0.58	V
Tdon	Output turn-on delay	Output turn-on delay time after RS becomes greater than input direction.	—	1.0	2.0	□sec
Tdoff	Output turn-off delay	Output turn-off delay time after RS becomes smaller than input direction.	—	2.0	3.5	□sec
Tdsw	Output switching delay	Output off time when output direction switches.	—	3.0	6.0	□sec
Ileak	Output leak current	MU1=5v	-100	—	100	□A

mitsubishi semiconductors
M63020FP
SPINDLE MOTOR AND 5CH ACTUATOR DRIVER

<ELECTRICAL CHARACTERISTICS>

Loading

(Ta=25°C, 5VCC=5V, VM1=VM2=12V unless otherwise noted.)

SYMBOL	PARAMETER	CONDITIONS	LIMITS			Unit
			MIN	TYP	MAX	
Vdyc3-1	Dynamic range of output	Io=0.5[A]	3.8	4.0	—	V
Vdyc3-2	Dynamic range of output	R=5.4[W] 5VCC=4.75[V], VM1=12[V]	3.2	3.4	—	V
Vin3	Control voltage input range3	LOIN+, LOIN-	0	—	5	V
Gvo3	Control gain 3	$\frac{(LO+) - (LO-)}{(LOIN+) - (LOIN-)}$	12.5	14	15.2	dB
Voff1-1	Output offset voltage	(LO+) - (LO-) at LOIN+=LOIN-=5V	-100	0	+100	mV
Voff1-2	Output offset voltage	(LO+) - (LO-) at LOIN+=LOIN-=1.65V	-50	0	+50	mV

Focus / Tracking

(Ta=25°C, 5VCC=5V, VM1=VM2=12V unless otherwise noted.)

SYMBOL	PARAMETER	CONDITIONS	LIMITS			Unit
			MIN	TYP	MAX	
Vdyc4	Dynamic range of output	Io=0.5[A] VM1=12[V]	3.8	4.2	—	V
Vin4	Control voltage input range 4	FOIN, TOIN	0	—	5	V
Gvo4	Control gain 4	$\frac{(FO+) - (FO-)}{FOIN-REF}$ $\frac{(TO+) - (TO-)}{TOIN-REF}$	12.5	14	15.2	dB
Voff2	Output offset voltage	(FO+) - (FO-) at REF=FOIN=1.65V (TO+) - (TO-) at REF=TOIN=1.65V	-35	0	+35	mV

NOTE : This IC need condenser between each supply lines and GND for stoped Oscillation.

<THERMAL CHARACTERISTICS>

SYMBOL	PARAMETER	FUNCTION START TEMPERATURE OF IC			FUNCTION STOP TEMPERATURE OF IC			Unit
		MIN	TYP	MAX	MIN	TYP	MAX	
TSD	Thermal Shut Down	—	160	—	—	130	—	°C

*note3

This TSD function start temperature doesn't show the guaranteed max. temperature of the devices. The guaranteed max. temperature is Tj max. which is shown in "9. ABSOLUTE MAXIMUM RATING". The TSD function is a thermal protection in case the temperature of the devices goes up above Tjmax because of wrong use.

And these TSD temperature are the target temperatures for circuit design, not the guaranteed temperatures. (The TSD function of all the devices is not checked by a test in high temperature.)

MITSUBISHI SEMICONDUCTORS
M63020FP
SPINDLE MOTOR AND 5CH ACTUATOR DRIVER

Standby function

Logic control		Drive channel					
	MU1	Loading	Slide1	Slide2	Focus	Tracking	Spindle
SELECT2	H	On	On	On	On	On	On
SELECT1	L/Open	Off	Off	Off	Off	Off	Off

This IC has MUTE terminal (MU1).

It is possible to control ON / OFF of the channel by external logic inputs.

In case of SELECT1, the bias of all circuit becomes OFF.

Therefore, this mode is available in order to reduce the power dissipation when the waiting mode.

In case of SELECT2, the bias of all channel becomes ON.

Regard with making OFF the loading channel in case of SELECT2, please refer to [Loading channel].

Brake select function

BSR	SPIN < REF	REF < SPIN
Hi	Reverse brake	Foward
L/Open	Short Brake	Foward

This IC has BRS terminal (BRS).

It is possible for a braking timing of Spindle drive to select which the short brake or the reverse brake by BRS. It should select the short brake in case of high speed system and please change to the reverse brake when the rotation speed becomes enough low. It is available when the SPIN voltage is low than the reference voltage.

Loading channel

The loading channel is the circuit of BTL voltage drive. This circuit has the referential input. Output swing is determined with $\Delta V_{in} \times 5$. Also, it is possible for this channel to use for the slide motor, the focus coil and the tracking coil.

The input terminal is high impedance. It is possible to do variable a gain by external resistor.

The output becomes high impedance in case of both input voltage becomes under 0.7 volts. It is possible for the input terminal to operate from 0 volts. The following table and diagram show an application in case of two MCU port and one MCU port for the loading motor. In case of one MCU port, if use three state port, it is possible for this channel to have the stop function.

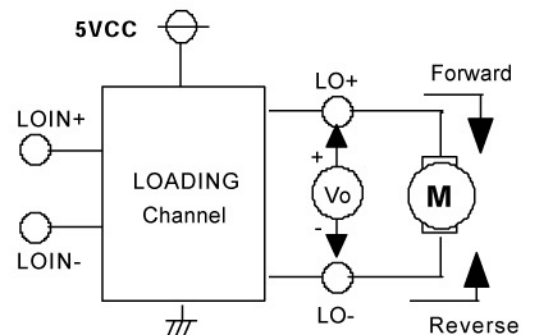

MITSUBISHI SEMICONDUCTORS
M63020FP
SPINDLE MOTOR AND 5CH ACTUATOR DRIVER

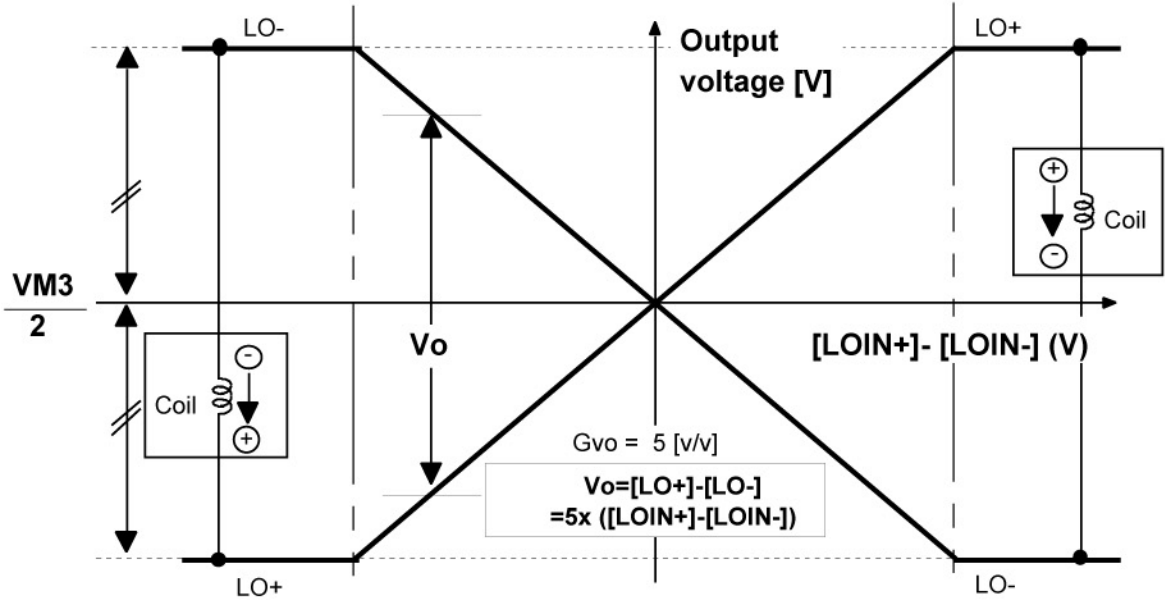

application.1 (Two port H/L control)

Logic control		Situation of loading channel	Output voltage swing
P1	P2		
5V	5V	Short brake --> Stop	$V_o = 0 [V]$
0	5V	Reverse rotation	$V_o = -5 \times 5 \times R_1 / (R_1 + 2 \times R_2)$
5V	0	Forward rotation	$V_o = 5 \times 5 \times R_1 / (R_1 + 2 \times R_2)$
0	0	Off [High impedance output]	Off

application.2 (One port H/Z/L control)

Logic control P1	Situation of loading channel	Output voltage swing
5v	Forward rotation	$V_o = \frac{2.5[V] \times 5 \times R_2}{(R_1/2) + R_2 + R_3}$
Z (Hi impedance)	Short brake --> Stop	$V_o = 0 [V]$
0	Reverse rotation	$V_o = -\frac{2.5[V] \times 5 \times R_2}{(R_1/2) + R_2 + R_3}$

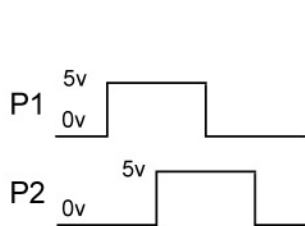

application.1
(Two port H/L control)

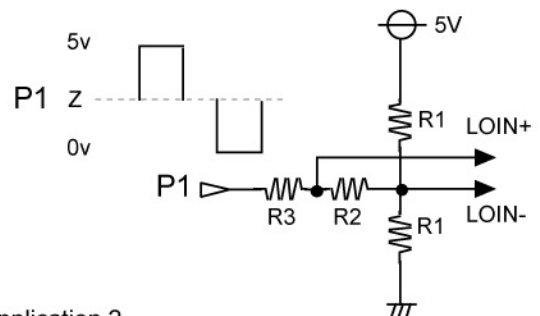
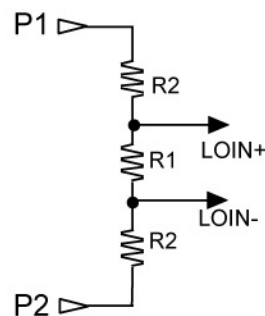

application.2
(One port H/Z/L control)

MITSUBISHI SEMICONDUCTORS
M63020FP
SPINDLE MOTOR AND 5CH ACTUATOR DRIVER

SPINDLE channel

The relationship between the differential voltage between SPIN and REF and the torque is shown in right Figure. The voltage gain[Gvo] is 1.0 [V/V].

The current gain[Gio] is 2.0[A/V] (at sensing resistor : 0.5 ohm, and R1=∞, R2=0ohm) in forward torque directions, and the dead zone is from 0mV to 60mV (at R1=∞, R2=0ohm) .

The coil current gain under the reverse torque is the same with in forward torque directions. And the limitation function gets on when the differential voltage of VM1(12V)~RSP is 0.5V.

Therefore current-gain-control and current-limit of this IC is determined with sensing resistor value, and more detail control can be determined with setting a gain-resistor outer this IC as below.

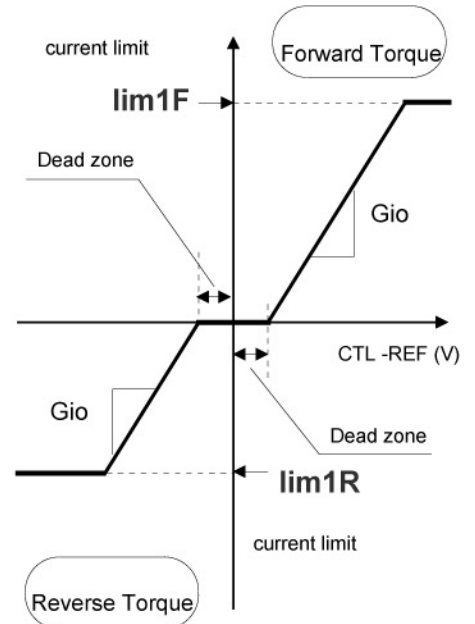

The example of current-gain and current-limit of SPINDLE.

Rs (Ω)	Ilim1F (A)	Ilim1R (A)	Gio* (A/V)		
			R1=∞ R2=0 ohm	R1=R2	R1=2•R2
0.50	1.00	0.56	2.00	1.00	0.66
0.75	0.66	0.37	1.33	0.66	0.44
1.00	0.50	0.28	1.00	0.50	0.33

$$G_{io}^* = R1 / [(R1+R2) + iRs] \text{ [A/V]}$$

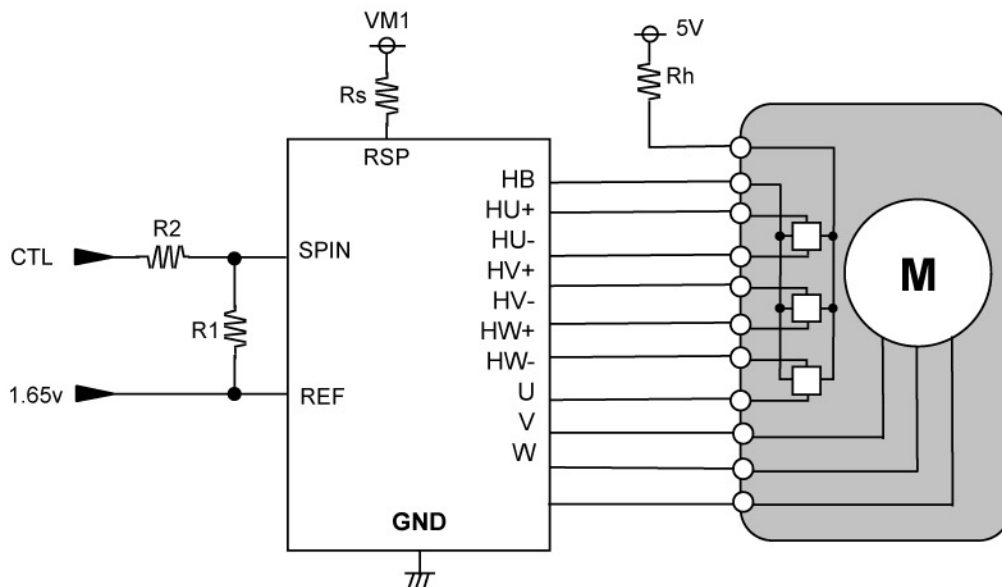

MITSUBISHI SEMICONDUCTORS
M63020FP
SPINDLE MOTOR AND 5CH ACTUATOR DRIVER

SLIDE channel

The relationship between the differential voltage between SLIN and REF and the torque is shown in right Figure. The voltage gain[Gvo] is 1.0 [V/V]. The current gain is 2.0[A/V] (at sensing resistor : 0.5 ohm and R1=∞, R2=0ohm) in forward torque directions, and the dead zone is from 0mV to 80mV (at R1=∞, R2=0ohm).

The coil current gain under the reverse torque is the same with in forward torque directions. And the limitation function gets on when the differential voltage of VM2(12V)~RSL is 0.5V. Therefore current-gain-control and current-limit of this IC is determined with sensing resistor value.

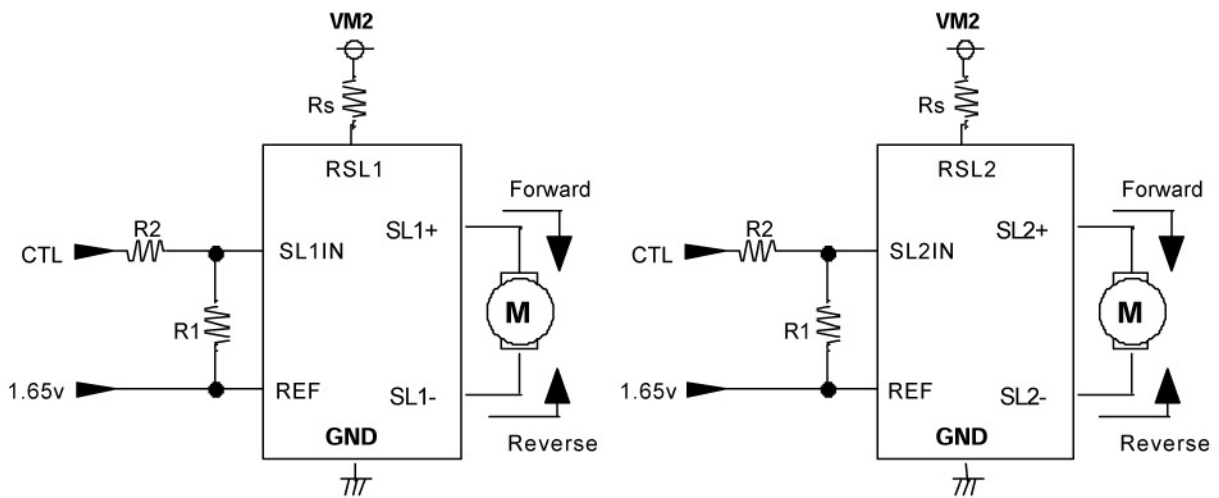
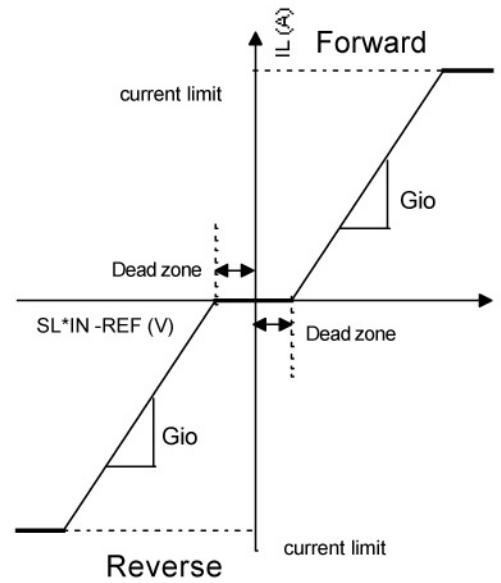

The example of current-gain and current-limit of SLIDE.

Rs [Ω]	Ilim [A]	Gio* [A/V]		
		R1=∞ R2=0 ohm	R1=R2	R1=2•R2
0.50	1.00	2.00	1.00	0.66
0.75	0.66	1.33	0.66	0.44
1.00	0.50	1.00	0.50	0.33

$$G_{io}^* = R_1 / [(R_1 + R_2) \cdot R_s] \text{ [A/V]}$$

MITSUBISHI SEMICONDUCTORS
M63020FP
SPINDLE MOTOR AND 5CH ACTUATOR DRIVER

FOCUS / TRACKING channel

The focus and tracking channel is the voltage control drive using BTL .

The focus and tracking is the same composition.

The relationship between the differential voltage between FOIN and REF and the output voltage is shown in below Figure.

The voltage gain [Gvo] is 5.0 [V/V].

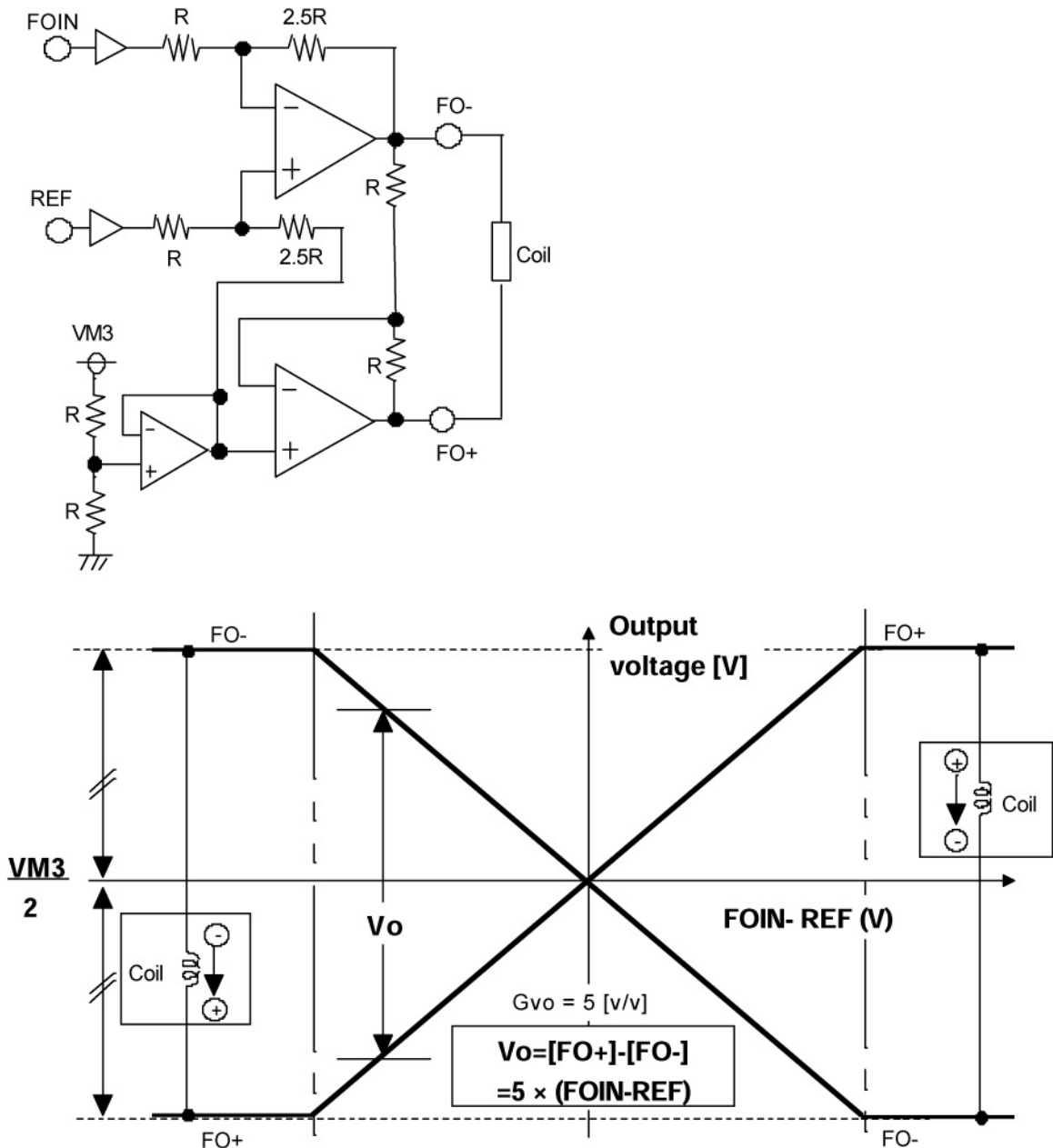

MITSUBISHI SEMICONDUCTORS
M6302FP
SPINDLE MOTOR AND 5CH ACTUATOR DRIVER

Direct PWM operation

The spindle and the slide channel is controlled by the direct PWM control.
 Also, built-in the current limit circuit. This IC controls the motor current directly.

FORWARD Current path timing 1.

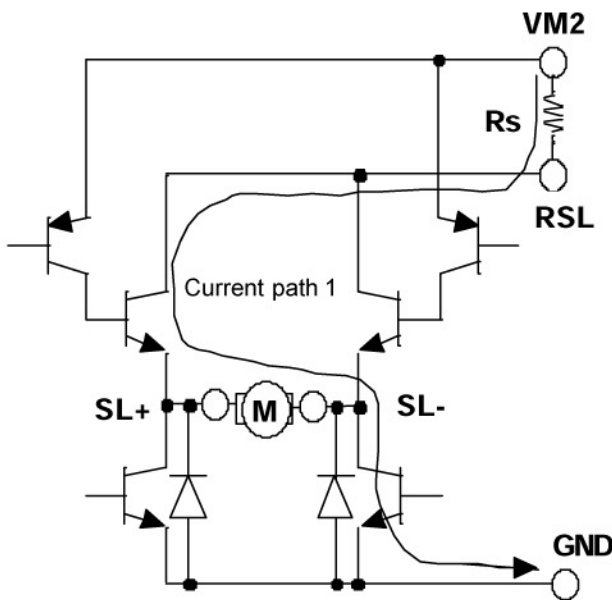

FORWARD Current path timing 2.

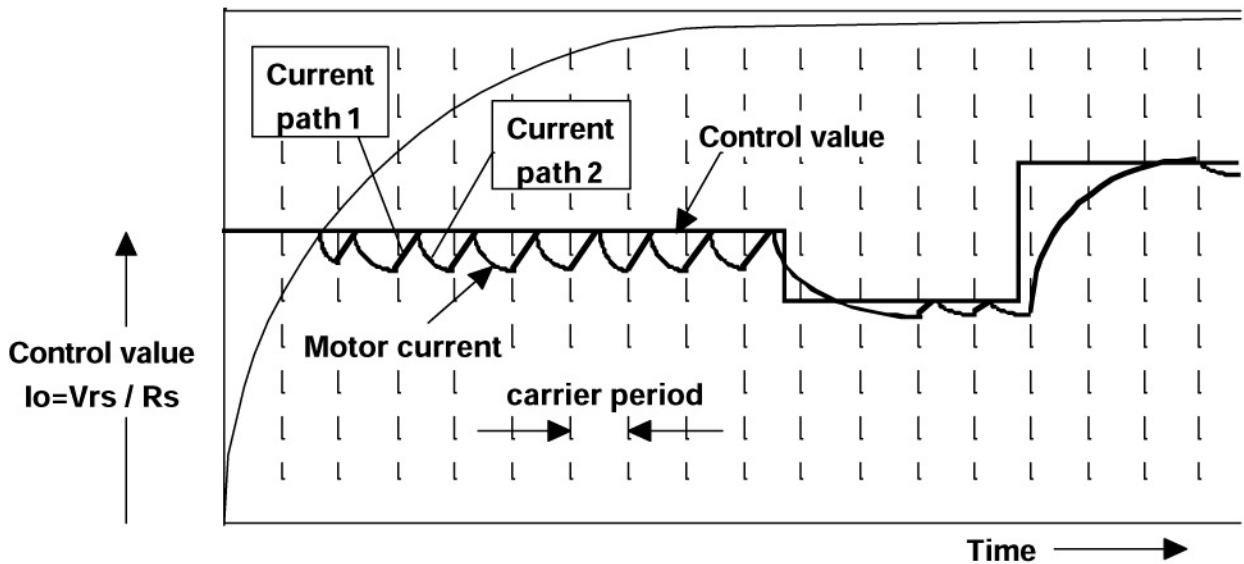
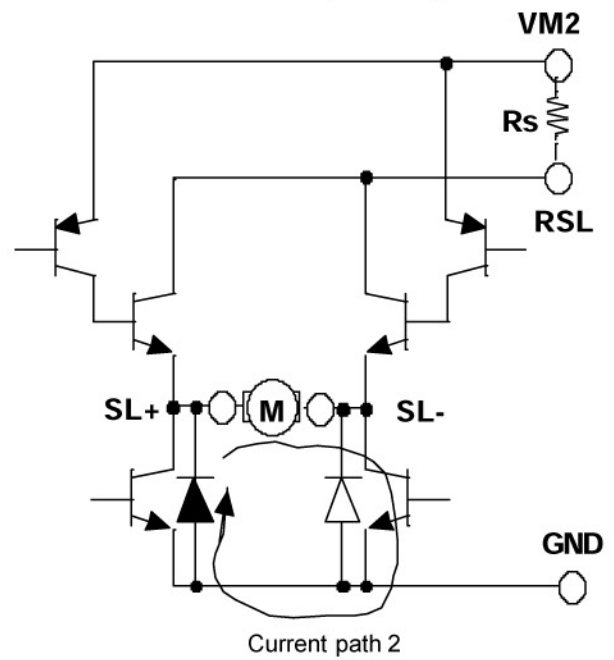

MITSUBISHI SEMICONDUCTORS
M63020FP
SPINDLE MOTOR AND 5CH ACTUATOR DRIVER

PWM carrier frequency setting

PWM carrier frequency is decided by charging and discharging the capacitor that is connected to OSC terminal outer IC. Examination of the relationship the capacitor connected to OSC terminal and PWM carrier frequency is given in following table.

Capacitor [pF]	820	750	330	220	180	130	110
Carrier Frequency [KHz]	28	30	65	90	110	140	160

*note) This PWM carrier frequency is TYP value.

Recommendation of SHORT BRAKE MODE at SPINDLE DRIVE

This IC has two brake mode, PWM-BRAKE-MODE and SHORT-BRAKE-MODE. In this IC recommendation, SHORT-BRAKE-MODE is superior to PWM-BRAKE-MODE to reducing the power dissipation and to avoid braking down of this IC. (By excessive reverse torque current in braking a motor with PWM-BRAKE from high-speed-rotation with being excessive Back-EMF, this IC could be broken.)

The relationship between hall-amplifier-input and output-current-commutation at SPINDLE DRIVE

The relationship between the hall elements and the motor output current is shown in bellow Figure.

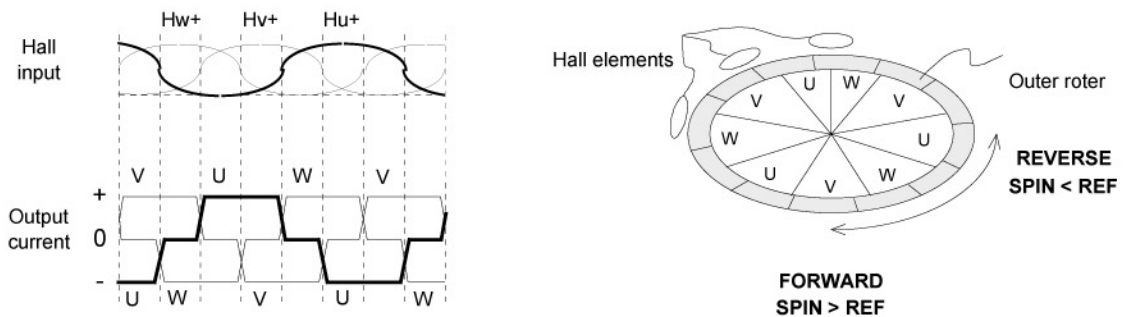

FG function at SPINDLE DRIVE

The FG terminal outputs the square pulse signal synchronizing with the Hall inputs [Hv+, Hv-] timing. And, the FG terminal is open-collector output.

Phase delay circuit at SLIDE

Phase delay circuit is built in the IC to detect an output spike current, when the motor current direction is switching.

In switching the motor current direction, Phase delay circuit switch-off all output transistor of H-bridge for 3 μ sec.

Output current setting at SLIDE

In this IC, since output transistor is NPN-type transistor, motor coil current (I_o) is larger than sensing resistance current about 20mA (TYP.) according to base current of output transistor. Therefore please design output current with considering these base current.

MITSUBISHI SEMICONDUCTORS
M63020FP
SPINDLE MOTOR AND 5CH ACTUATOR DRIVER

I/O circuit

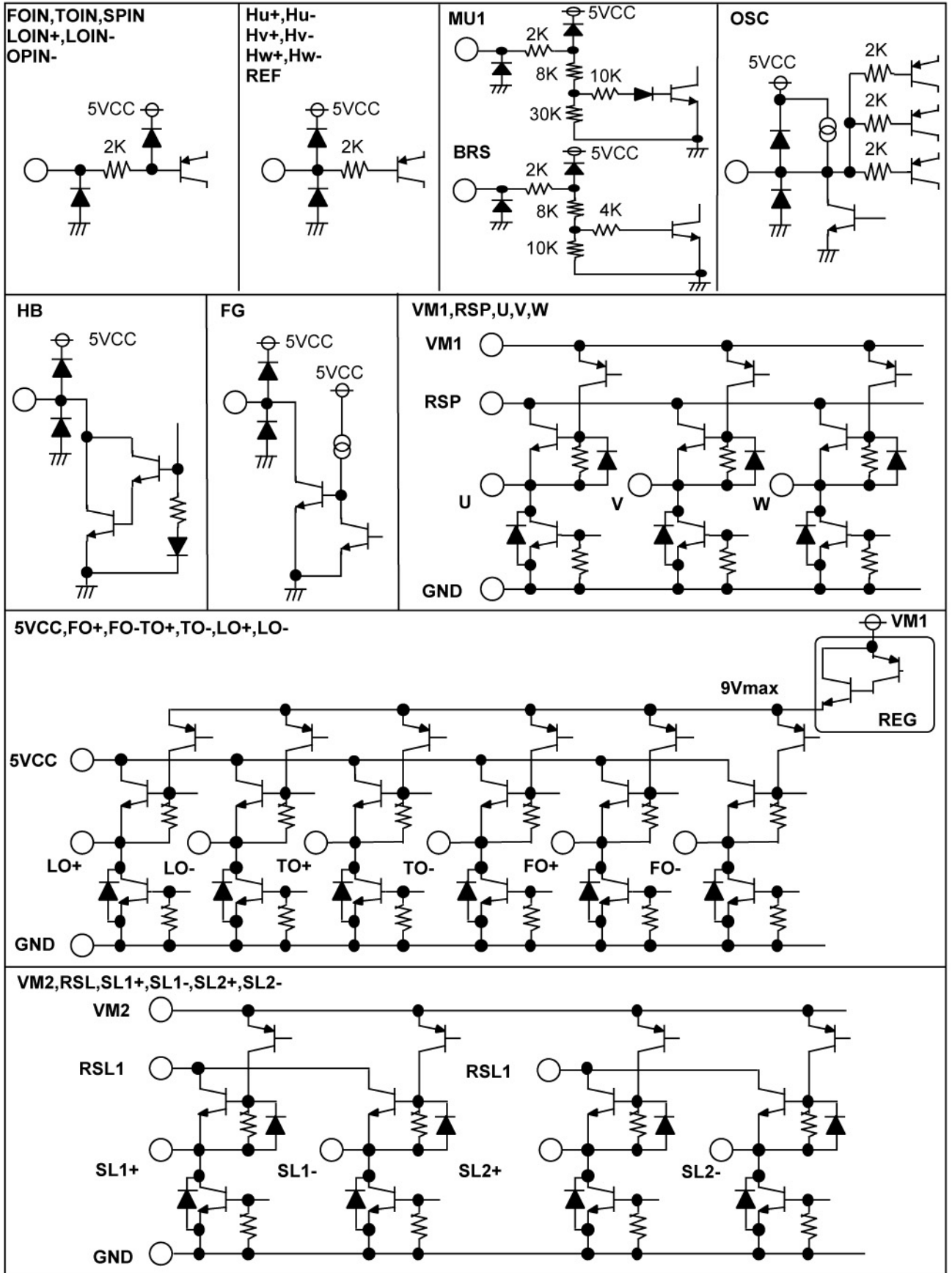

MITSUBISHI SEMICONDUCTORS
M63020FP
 SPINDLE MOTOR AND 5CH ACTUATOR DRIVER

[The boards for thermal derating evaluation]

Board material
 Glass-epoxy FR-4

Size
 70×70mm

thickness
 t=1.6mm

1 and 2 layers

material :copper

thickness:t=18μm

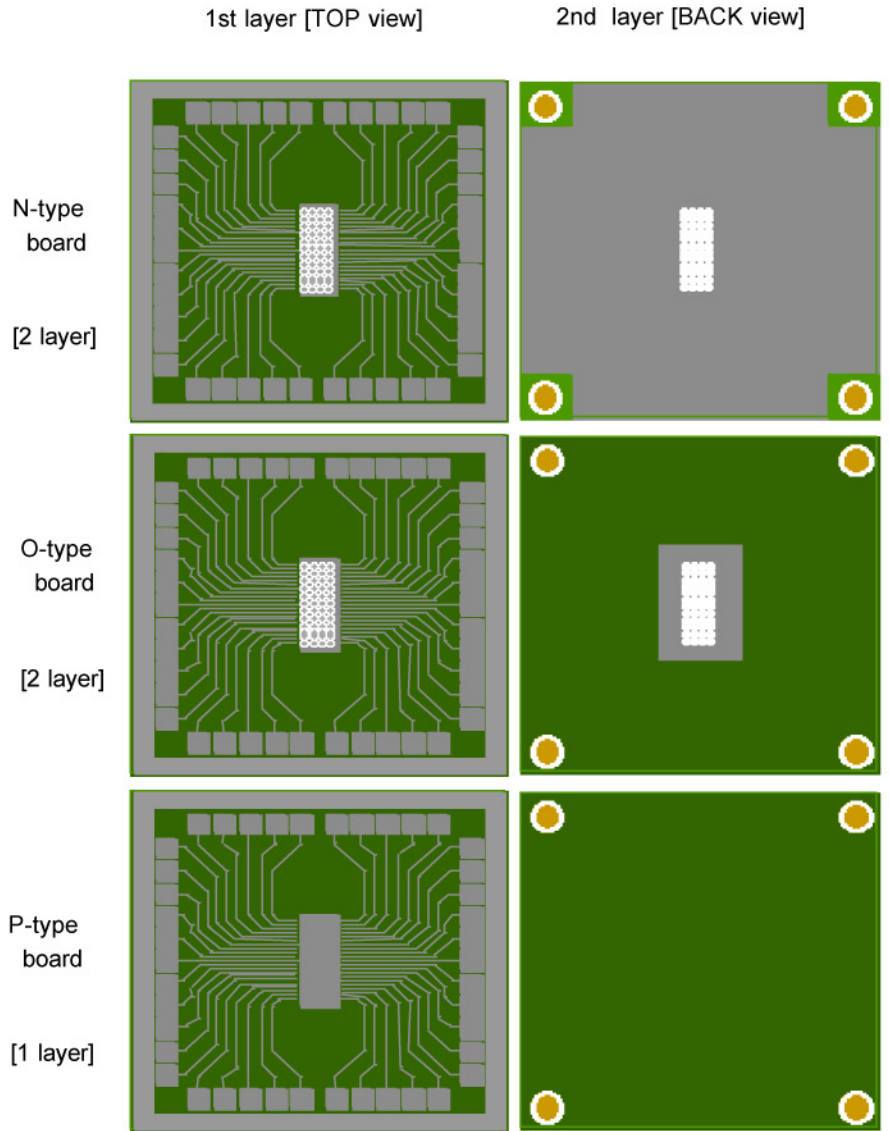
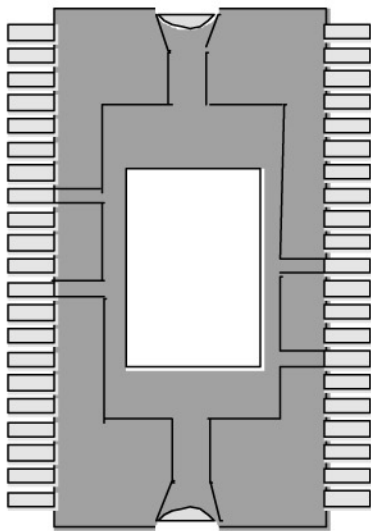

POWER-SSOP 42P9R-B

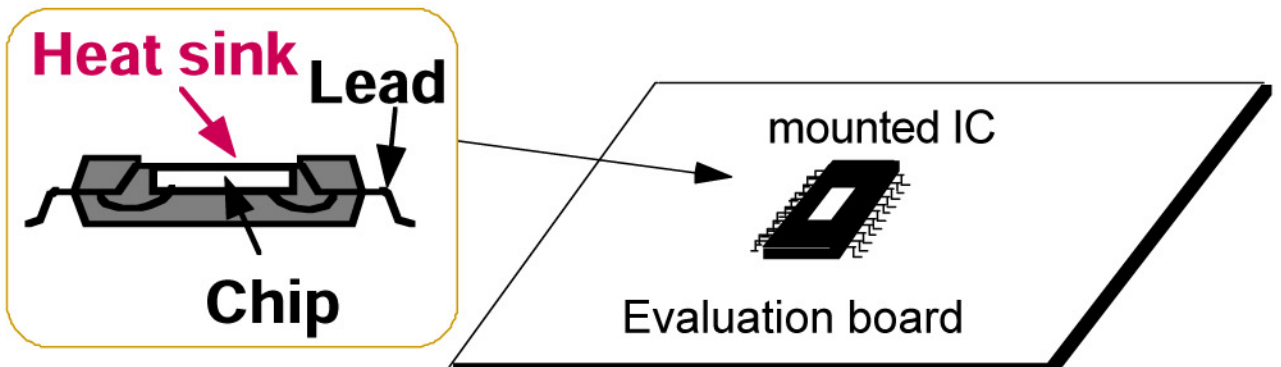

MITSUBISHI SEMICONDUCTORS
M63020FP
SPINDLE MOTOR AND 5CH ACTUATOR DRIVER

[APPLICATION CIRCUIT no.1]

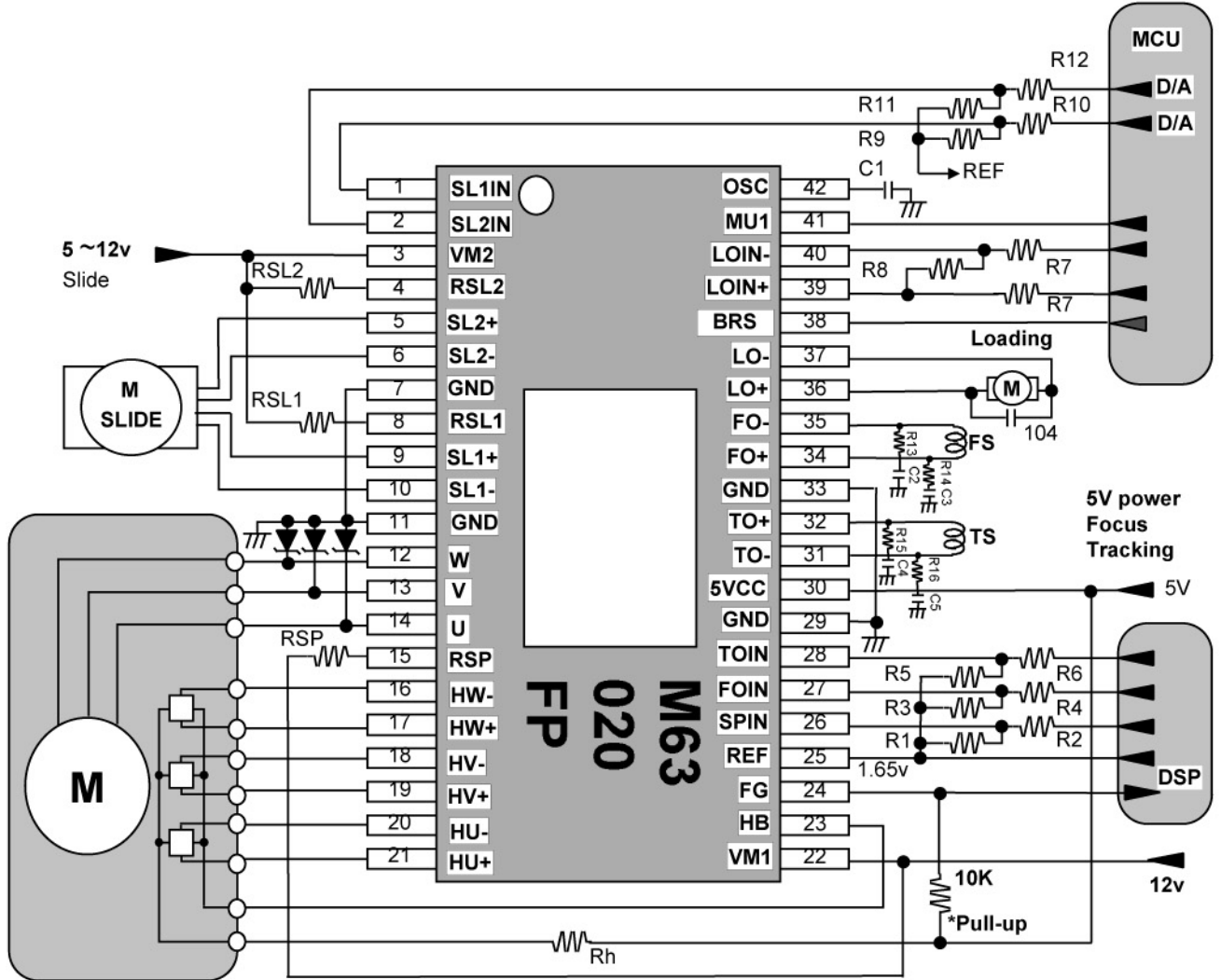

Note) refers to Schotky diode.

<Example values for external parts>

(Values below are not guaranteed ones but recommended)

Part name	Value(typ)	Unit	Remark
RSP	0.33	Ω	Ilim1F=1.5A, Ilim1R=1.0A, Gain=3.0A/V
RSL1, RSL2	2	Ω	Ilim=0.5A, Gain=1A/V
Rh	200	Ω	
R1, R2, R3, R4, R5, R6	10K	Ω	Depends on your spec.
R7, R8	10K	Ω	Depends on your spec.
C1	330p	Φ	Fosc=65KHz
R9, R10, R11, R12	10K	Ω	Depends on your spec.
D1, D2, D3	-	V	VF<0.5V at IL=1.0A is recommendable.
R13, R14, R15, R16	22	Ω	
C2, C3, C4, C5	10n	F	