

IS31BL3230

8 CHANNELS CONSTANT CURRENT LED DRIVER WITH PWM BRIGHTNESS CONTROL

February 2012

GENERAL DESCRIPTION

The IS31BL3230 provides eight regulated current sources, each delivers up to 40mA of load current with careful selection of external sense resistors, all outputs at the IS31BL3230 may be connected in parallel to enable the current through the LED to be as high as 320mA.

The IS31BL3230 does not include a charge pump and therefore has no noise and significantly improved the efficiency. The external resistor, R_{SET1} , determines the constant current output of ports LED1 thru LED4, while resistor R_{SET2} determines the constant current output of ports LED5 thru LED8.

Brightness can be controlled with PWM techniques. The constant current source is set with two external sense resistors.

Alternatively, a PWM signal applied to the PWM pin can vary the perceived brightness of the LED. The device is in shut down mode when the PWM Input is logic low.

FEATURES

- Ultra low headroom voltage
- Cost effective LED driver
- Current adjustable via external resistors
- Best Noise and Efficiency Performance
- Highly integrated design, minimal component
- 1.6 μ A (typ.) Shutdown current
- Small package QFN-16 3mm \times 3mm

APPLICATIONS

- Flash LED driver
- Backlight LED driver

TYPICAL APPLICATION CIRCUIT

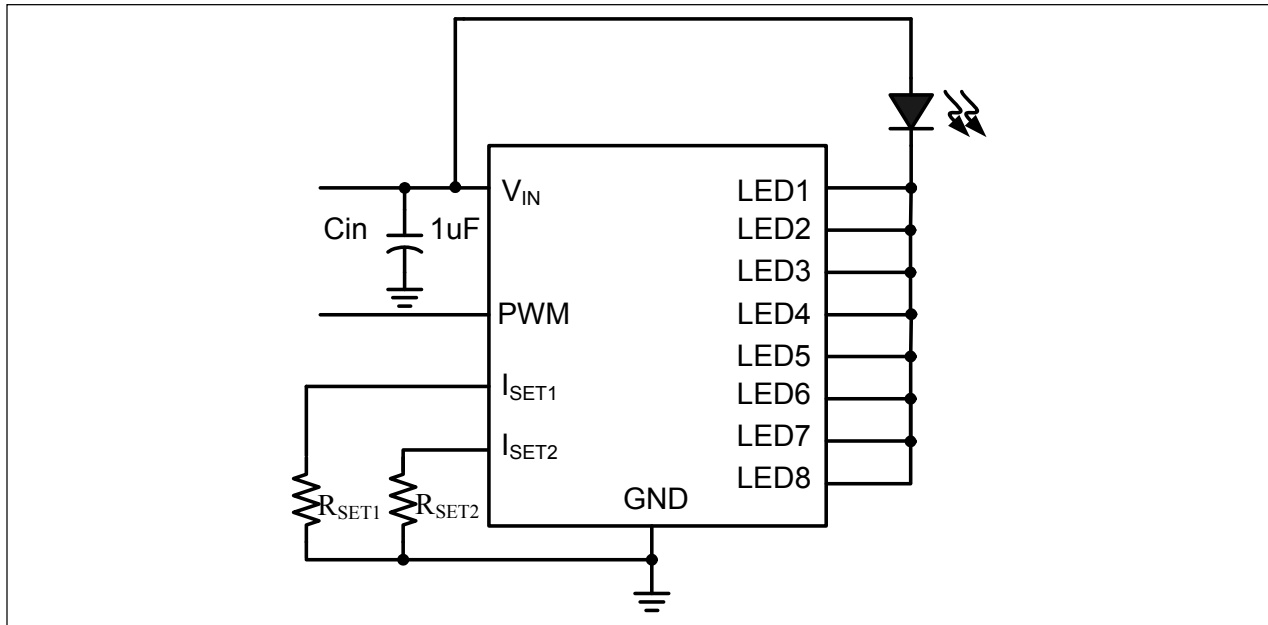
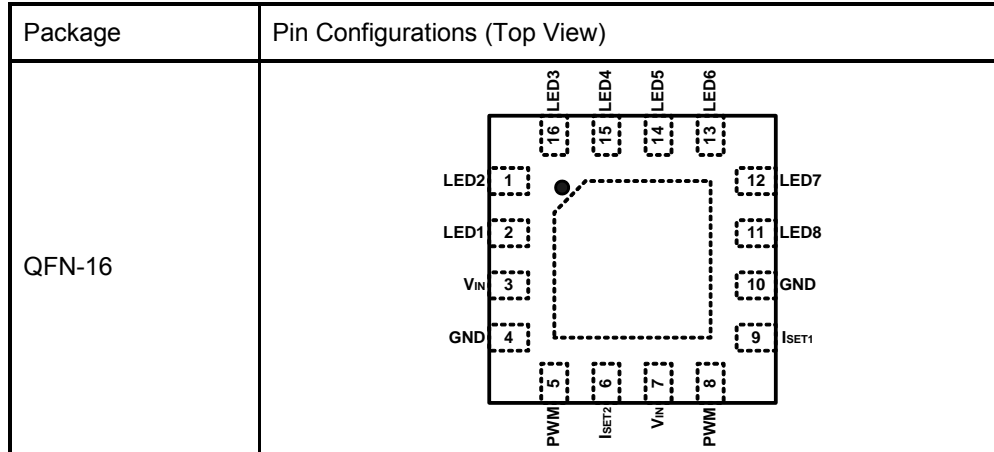

Figure 1 Typical Application Circuit

IS31BL3230

PIN CONFIGURATION



PIN DESCRIPTION

No.	Name	Description
1, 2, 11~16	LED1-LED8	Current source outputs 1~8.
3, 7	V _{IN}	Input voltage.
4, 10	GND	Ground.
5, 8	PWM	PWM brightness control.
6	I _{SET1}	Current set1 input.
9	I _{SET2}	Current set2 input.

Copyright © 2011 Integrated Silicon Solution, Inc. All rights reserved. ISSI reserves the right to make changes to this specification and its products at any time without notice. ISSI assumes no liability arising out of the application or use of any information, products or services described herein. Customers are advised to obtain the latest version of this device specification before relying on any published information and before placing orders for products. Integrated Silicon Solution, Inc. does not recommend the use of any of its products in life support applications where the failure or malfunction of the product can reasonably be expected to cause failure of the life support system or to significantly affect its safety or effectiveness. Products are not authorized for use in such applications unless Integrated Silicon Solution, Inc. receives written assurance to its satisfaction, that:

- a.) the risk of injury or damage has been minimized;
- b.) the user assume all such risks; and
- c.) potential liability of Integrated Silicon Solution, Inc is adequately protected under the circumstances



IS31BL3230

ORDERING INFORMATION

Industrial Range: -40°C to +85°C

Order Part No.	Package	QTY/Reel
IS31BL3230-QFLS2-TR	QFN-16, Lead-free	2500



IS31BL3230

ABSOLUTE MAXIMUM RATINGS

Supply voltage, V_{IN}	-0.3V ~ +6.0V
PWM	-0.3V to $(V_{IN}+0.3V) / 6.0V$
Maximum junction temperature, T_{JMAX}	150°C
Storage temperature range, T_{STG}	-65°C ~ +150°C
Operating temperature range, T_A	-40°C ~ +85°C

Note:

Stresses beyond those listed under “Absolute Maximum Ratings” may cause permanent damage to the device. These are stress ratings only and functional operation of the device at these or any other condition beyond those indicated in the operational sections of the specifications is not implied. Exposure to absolute maximum rating conditions for extended periods may affect device reliability.

ELECTRICAL CHARACTERISTICS

Unless otherwise specified or noted, $V_{IN} = 3.6V$, $R_{SET}=7.5k\Omega$, $V_{LEDX}=0.5V$. Limits apply for $T_A=25^\circ C$. (Note)

Symbol	Parameter	Condition	Min	Typ.	Max	Units
V_{IN}	Supply Voltage		2.7		5.5	V
I_{LEDX}	Output Current Regulation	$0.4V \leq V_{LEDX} \leq 2.0V$, $R_{SET} = 7.5k\Omega$		16.0		mA
V_{HR}	Minimum Headroom Voltage(LEDX)	$R_{SET}=7.5k\Omega$, $I_{LEDX}=20.0mA$		44.0		mV
V_{SET}	I_{SET} PIN Voltage			1.2		V
I_{LEDX}/I_{SET}	Output Current to Current Set Ratio			100.0		mA/mA
I_Q	Quiescent Supply Current	$I_{LEDX}=0mA$, $I_{SET}=Float$		244.0		μA
I_{PWM}	Shutdown Supply Current	PWM=0		1.6		μA
V_{PWM-IH}	PWM Input Logic High	$3.0V \leq V_{IN} \leq 5.5V$	1.4			V
V_{PWM-IL}	PWM Input Logic Low	$3.0V \leq V_{IN} \leq 5.5V$			0.4	V
I_{PWM}	PWM Pin Current	$V(PWM) = 1.5V$		5.6		μA

Note: Production testing of the device is performed at 25°C. Functional operation of the device and parameters specified over other temperature range, are guaranteed by design, characterization and process control.

IS31BL3230

TYPICAL PERFORMANCE CHARACTERISTICS

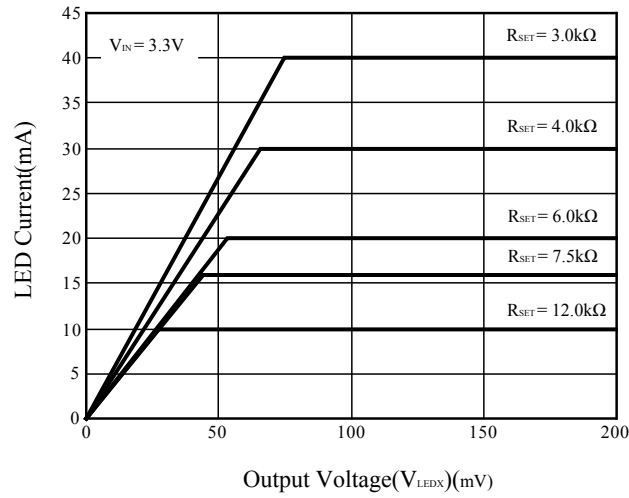

Figure 2 Output Voltage vs. LED Current

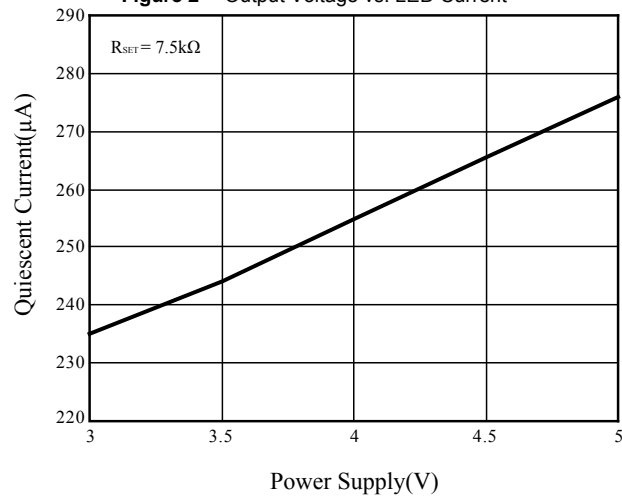

Figure 4 Power Supply vs. Quiescent Current

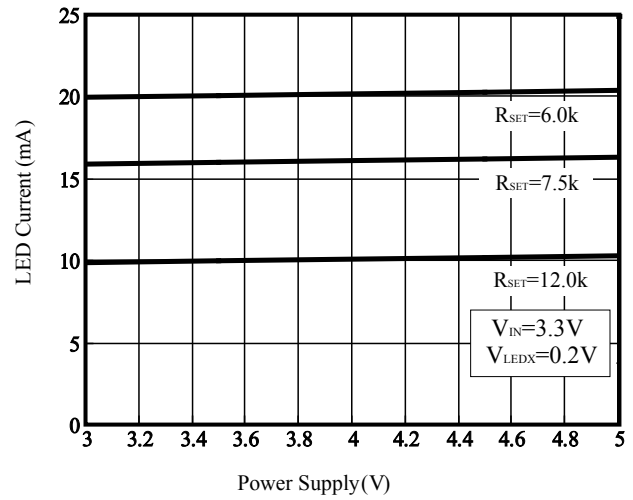

Figure 3 Power Supply vs. LED Current

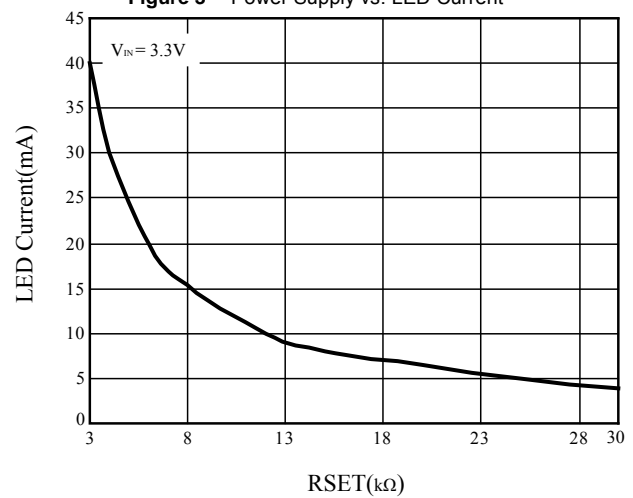

Figure 5 R_{SET} vs. LED Current

IS31BL3230

APPLICATION INFORMATION

CIRCUIT DESCRIPTION

The IS31BL3230 is a white-LED driver with eight matched current outputs. The matched current regulators each has a 100:1 current ratio between the LED_x outputs and the I_{SET} currents. The mirror controls the current through the LEDs without the use of external ballast resistors. With a total of 320mA of total output current available, the IS31BL3230 is capable of providing 40mA to each of the eight outputs through the proper selection of the R_{SET1} & R_{SET2} resistor. LED brightness control can be achieved on the IS31BL3230 with PWM signal.

SHUTDOWN

When the voltage on the active-high-logic PWM pin is low, the IS31BL3230 will be in shutdown mode. While disabled, the IS31BL3230 typically draws 1.6µA from the power supply. There is no internal pull-up or pull-down on the PWM pin of the IS31BL3230.

OUTPUT CURRENT CAPABILITY

The IS31BL3230 can provide up to 40mA of current to each of the eight outputs given an input voltage of 2.7V to 5.5V. An external resistor can be used to set the output current, as approximated with the following the equation:

$$R_{SET1,2} = 100 \times (V_{ISET1,2} / I_{LEDX})$$

R_{SET1} determines the constant current output of ports LED1 thru LED4, R_{SET2} determines the constant current output of ports LED5 thru LED8, V_{ISET} is the voltage of R_{SET} resistance, it is 1.20V typically. In order for the output currents to be regulated properly, sufficient headroom voltage (V_{HR}) is required. The headroom voltage refers to the minimum amount of voltage that must be present across the current source in order to ensure the desired current is realizable. To ensure the desired current is obtained, using the following equations to find the minimum input voltage required:

$$V_{IN} - V_{LEDX} \geq V_{HR}$$

V_{LEDX} is the diode forward voltage; V_{HR} is typically as shown in table1.

Table1. I_{LED}, R_{SET} and V_{HR-MIN}, V_{CC}=3.3V

I _{LED}	R _{SET}	V _{HEADROOM}
10.0mA	12.0kΩ	27 mV(typ.)
16.0mA	7.5kΩ	44 mV(typ.)
20.0mA	6.0kΩ	53 mV(typ.)
30.0mA	4.0kΩ	66 mV(typ.)
40.0mA	3.0kΩ	75 mV(typ.)

PWM BRIGHTNESS CONTROL

Brightness control can be implemented by pulsing a signal at the PWM pin.

The R_{SET} value should be selected using the R_{SET} equation. The LED brightness is proportional to the duty cycle (D) of the PWM signal. The PWM frequency (f) should be limited to accommodate the turn-on time (T_{ON}=50µs) of the device.

$$D \times (1/f) > T_{ON}$$

$$f_{MAX} = D_{MIN} / T_{ON}$$

If the PWM frequency is much less than 100Hz, flicker may be seen in the LEDs. For the IS31BL3230, zero duty cycle will turn off the LEDs and a 50% duty cycle will result in an average I_{LED} being half of the programmed LED current. For example, if R_{SET} is set to program 16mA, a 50% duty cycle will result in an average I_{LED} of 8mA, I_{LED} being half the programmed LED current. R_{SET} should be chosen not to exceed the maximum current delivery capability of the device.

LED SELECTION

The IS31BL3230 has ultra low headroom voltage and it is designed to drive white-LEDs with a typical forward voltage up to 3.5V.

As the voltage drop below the recommend V_{HR}, the drive current will automatically scale down to reduce the LED current consumption.

POWER DISSIPATION

The maximum allowable power dissipation that this package can handle is determined by the following:

$$P_{DMax} = (T_{JMax} - T_A) / \theta_{JA}$$

Where T_{JMAX} is the maximum junction temperature, T_A is the ambient temperature and θ_{JA} is the junction-to-ambient thermal resistance of the specified package. The IS31BL3230 come in the QFN-16 3mm×3mm package, and it has a junction-to-ambient thermal resistance (θ_{JA}) equal to 34.5°C/W. This value of θ_{JA} is highly dependant upon the layout of the PC board. The actual power dissipated by the IS31BL3230 follows the equation:

$$P_{DISS} = (V_{IN} \times I_{CC}) - N(V_{LEDX} \times I_{LEDX})$$

Where N equals the number of active outputs, V_{LEDX} is the LED forward voltage, and I_{LEDX} is the current supplied to the LED.

INPUT CAPACITOR SELECTION

The IS31BL3230 is designed to run off of a fixed input voltage. Depending on the stability and condition of this voltage rail, it may be necessary to add some small input capacitors to help filter out any noise that may be present on the line. In the event that filtering is needed, surface-mount multi-layer ceramic capacitors are recommended. These capacitors are small and inexpensive. Two capacitances, a 0.1µF and a 1µF are typically sufficient.

IS31BL3230

CLASSIFICATION REFLOW PROFILES

Profile Feature	Pb-Free Assembly
Preheat & Soak Temperature min (T _{smin}) Temperature max (T _{smax}) Time (T _{smin} to T _{smax}) (t _s)	150°C 200°C 60-120 seconds
Average ramp-up rate (T _{smax} to T _p)	3°C/second max.
Liquidous temperature (T _L) Time at liquidous (t _L)	217°C 60-150 seconds
Peak package body temperature (T _p)*	Max 260°C
Time (t _p)** within 5°C of the specified classification temperature (T _c)	Max 30 seconds
Average ramp-down rate (T _p to T _{smax})	6°C/second max.
Time 25°C to peak temperature	8 minutes max.

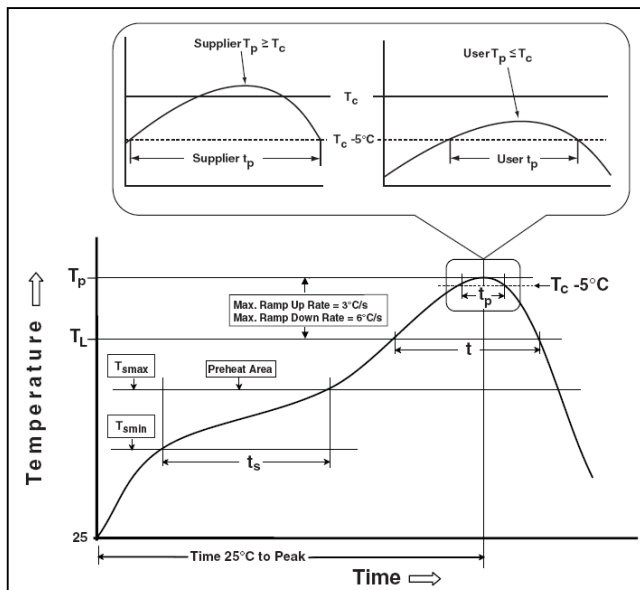
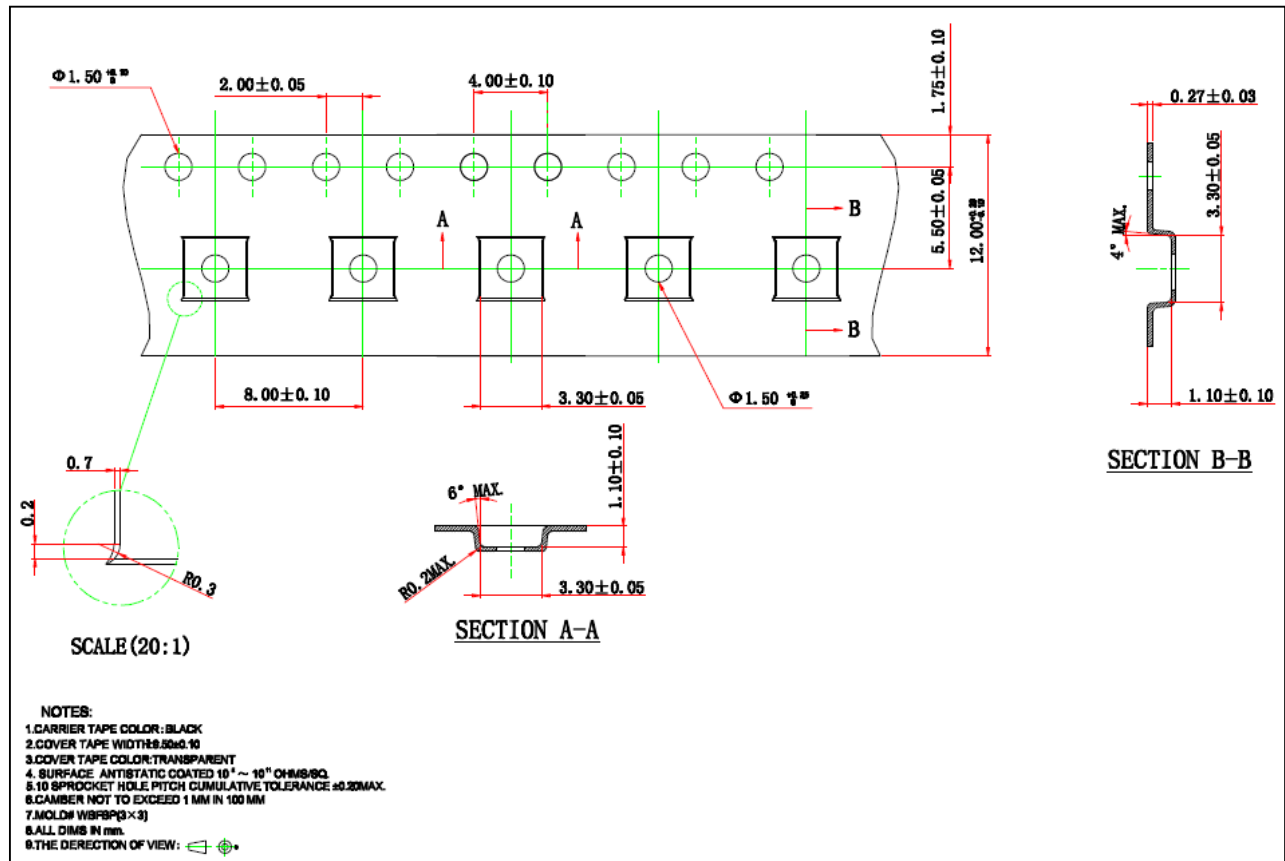

Figure 6 Classification Profile

IS31BL3230

TAPE AND REEL INFORMATION



IS31BL3230

PACKAGE INFORMATION

QFN-16

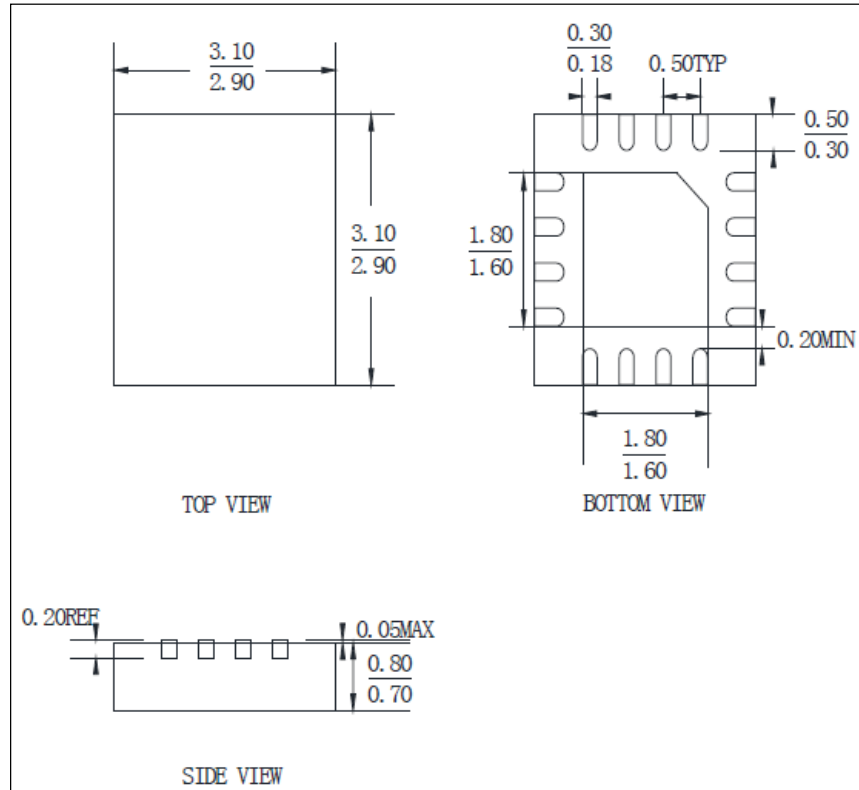

Note: All dimensions in millimeters unless otherwise stated.