

isc Silicon PNP Power Transistor

2SB946A

DESCRIPTION

- Low Collector Saturation Voltage-  
:  $V_{CE(sat)} = -0.5V(\text{Max}) @ I_C = -5A$
- Good Linearity of  $h_{FE}$
- Large Collector Current  $I_C$
- Complement to Type 2SD1271A

APPLICATIONS

- Designed for power switching applications

ABSOLUTE MAXIMUM RATINGS( $T_a=25^\circ\text{C}$ )

SYMBOL	PARAMETER	VALUE	UNIT
$V_{CBO}$	Collector-Base Voltage	-150	V
$V_{CEO}$	Collector-Emitter Voltage	-100	V
$V_{EBO}$	Emitter-Base Voltage	-7	V
$I_C$	Collector Current-Continuous	-7	A
$I_{CM}$	Collector Current-Peak	-15	A
$P_C$	Collector Power Dissipation @ $T_a=25^\circ\text{C}$	2	W
	Collector Power Dissipation @ $T_c=25^\circ\text{C}$	40	
$T_J$	Junction Temperature	150	$^\circ\text{C}$
$T_{stg}$	Storage Temperature Range	-55~150	$^\circ\text{C}$

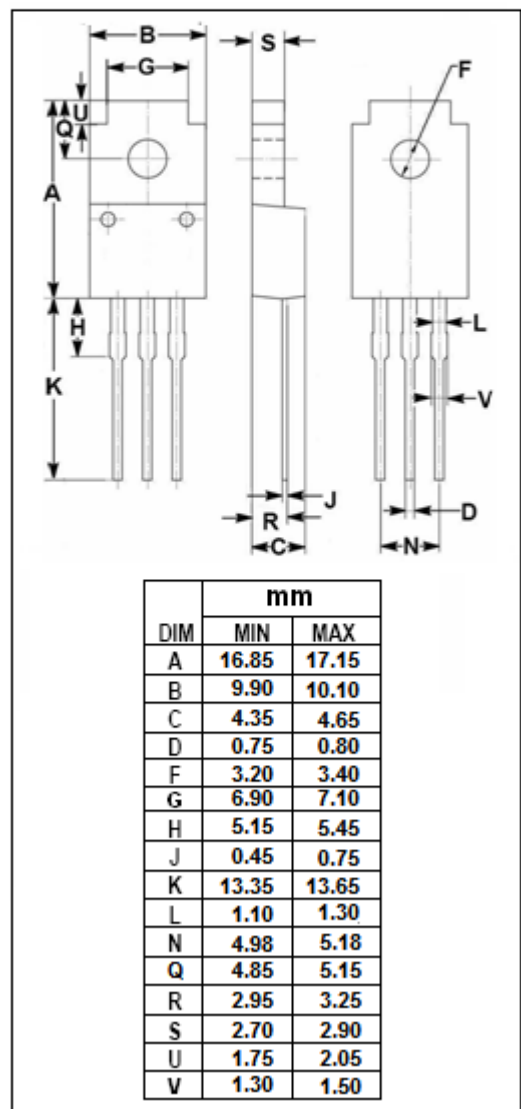
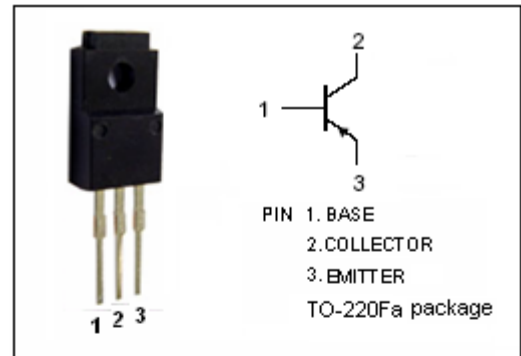

## isc Silicon PNP Power Transistor

2SB946A

## ELECTRICAL CHARACTERISTICS

 $T_C=25^{\circ}\text{C}$  unless otherwise specified

SYMBOL	PARAMETER	CONDITIONS	MIN	TYP.	MAX	UNIT
$V_{(BR)CEO}$	Collector-Emitter Breakdown Voltage	$I_C = -10\text{mA}$ ; $I_B = 0$	-100			V
$V_{CE(sat)}$	Collector-Emitter Saturation Voltage	$I_C = -5\text{A}$ ; $I_B = -0.25\text{A}$			-0.5	V
$V_{BE(sat)}$	Base-Emitter Saturation Voltage	$I_C = -5\text{A}$ ; $I_B = -0.25\text{A}$			-1.5	V
$I_{CBO}$	Collector Cutoff Current	$V_{CB} = -100\text{V}$ ; $I_E = 0$			-10	$\mu\text{A}$
$I_{EBO}$	Emitter Cutoff Current	$V_{EB} = -5\text{V}$ ; $I_C = 0$			-50	$\mu\text{A}$
$h_{FE-1}$	DC Current Gain	$I_C = -0.1\text{A}$ ; $V_{CE} = -2\text{V}$	45			
$h_{FE-2}$	DC Current Gain	$I_C = -3\text{A}$ ; $V_{CE} = -2\text{V}$	60		260	
$f_T$	Current-Gain—Bandwidth Product	$I_C = -0.5\text{A}$ ; $V_{CE} = -10\text{V}$ ; $f_{test} = 10\text{MHz}$		30		MHz

## Switching times

$t_{on}$	Turn-on Time	$I_C = -3.0\text{A}$ , $I_{B1} = -I_{B2} = -0.3\text{A}$ ,		0.5		$\mu\text{s}$
$t_{stg}$	Storage Time			1.5		$\mu\text{s}$
$t_f$	Fall Time			0.1		$\mu\text{s}$

◆  $h_{FE-2}$  Classifications

R	Q	P
60-120	90-180	130-260