

# SPECIFICATION FOR APPROVAL

- ( ◆ ) Preliminary Specification
- (   ) Final Specification

Title	9.7" XGA TFT LCD
-------	------------------

Customer	
MODEL	

SUPPLIER	LG Display Co., Ltd.
*MODEL	LP097X02
Suffix	SLA2

\*When you obtain standard approval,  
please use the above model name without suffix

APPROVED BY	SIGNATURE
/	_____
/	_____
/	_____

APPROVED BY	SIGNATURE
J. K. Kim / S. Manager	_____
REVIEWED BY	
K. T. Moon / Manager	_____
PREPARED BY	
H. H. Lee / Engineer	_____

Please return 1 copy for your confirmation with your signature and comments.

**Product Engineering Dept.  
LG Display Co., Ltd**

## Product Specification

## Contents

No	ITEM	Page
	COVER	1
	CONTENTS	2
	RECORD OF REVISIONS	3
1	GENERAL DESCRIPTION	4
2	ABSOLUTE MAXIMUM RATINGS	5
3	ELECTRICAL SPECIFICATIONS	
3-1	ELECTRICAL CHARACTREISTICS	6
3-2	INTERFACE CONNECTIONS	7
3-3	LVDS SIGNAL TIMING SPECIFICATIONS	8
3-4	SIGNAL TIMING SPECIFICATIONS	10
3-5	SIGNAL TIMING WAVEFORMS	10
3-6	COLOR INPUT DATA REFERNECE	11
3-7	POWER SEQUENCE	
4	OPTICAL SFECIFICATIONS	13
5	MECHANICAL CHARACTERISTICS	17
6	RELIABILITY	21
7	INTERNATIONAL STANDARDS	
7-1	SAFETY	22
7-2	EMC	22
8	PACKING	
8-1	DESIGNATION OF LOT MARK	23
8-2	PACKING FORM	23
9	PRECAUTIONS	24
A	APPENDIX. Enhanced Extended Display Identification Data	26



Product Specification

## 1. General Description

The LP097X02 is a Color Active Matrix Liquid Crystal Display with an integral LED backlight system. The matrix employs a-Si Thin Film Transistor as the active element. It is a transmissive type display operating in the normally Black mode. This TFT-LCD has 9.7 inches diagonally measured active display area with XGA resolution(1024 horizontal by 768 vertical pixel array). Each pixel is divided into Red, Green and Blue sub-pixels or dots which are arranged in vertical stripes. Gray scale or the brightness of the sub-pixel color is determined with a 6-bit gray scale signal for each dot, thus, presenting a palette of more than 262,144 colors.

The LP097X02 has been designed to apply the interface method that enables low power, high speed, low EMI. The LP097X02 is intended to support applications where thin thickness, low power are critical factors and graphic displays are important. In combination with the vertical arrangement of the sub-pixels, the LP097X02 characteristics provide an excellent flat display for office automation products such as Notebook PC.

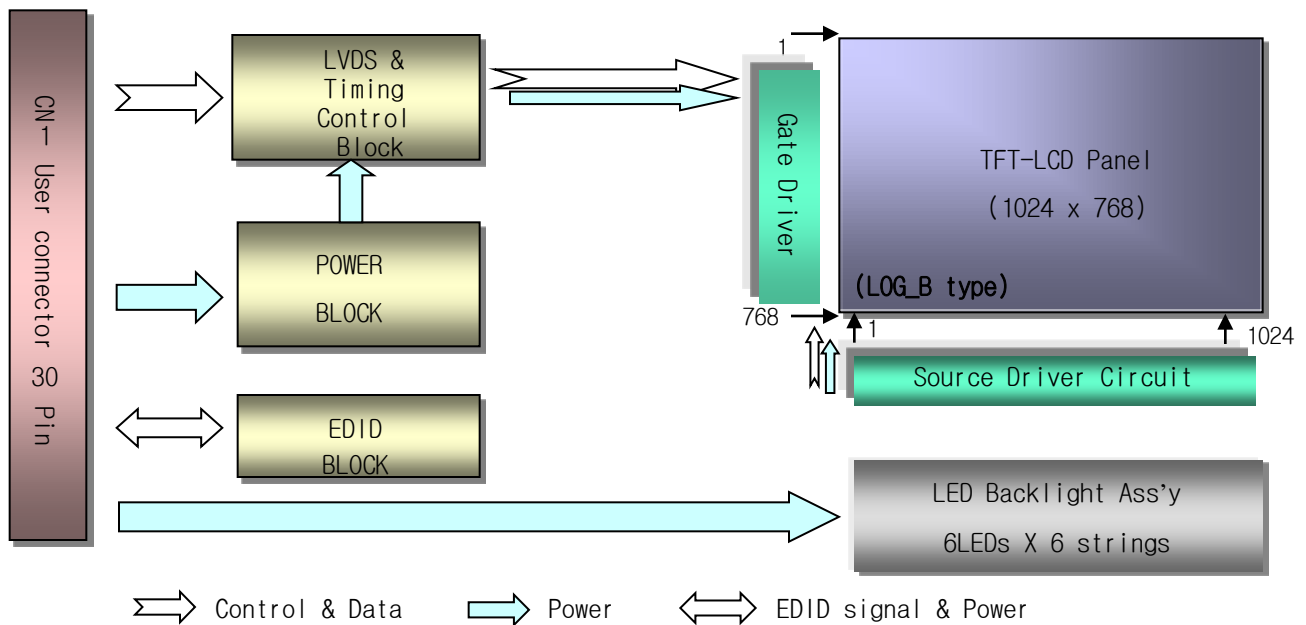

## General Features

Active Screen Size	9.7 inches diagonal
Outline Dimension	210.53(H) × 166.53 (V) × 3.55(D, Max.) mm ※ PCB area : 5.82(Max.)
Pixel Pitch	0.192 mm × 0.192 mm
Pixel Format	1024 horiz. by 768 vert. Pixels RGB strip arrangement
Color Depth	6-bit, 262,144 colors
Luminance, White	400 cd/m <sup>2</sup> (Typ., @I <sub>LED</sub> =20mA)
Power Consumption	Logic : 0.8W(typ.@Mosaic), Back Light : 2.1W (typ.@ I <sub>LED</sub> = 20mA)
Weight	160g (Max.)
Display Operating Mode	Transmissive mode, normally Black
Surface Treatment	Glare, Anti-reflective treatment of the front polarizer, 3H

Product Specification

## 2. Absolute Maximum Ratings

The following are maximum values which, if exceeded, may cause faulty operation or damage to the unit.

**Table 1. ABSOLUTE MAXIMUM RATINGS**

Parameter	Symbol	Values		Units	Notes
		Min	Max		
Power Input Voltage	VCC	-0.3	4.0	Vdc	at 25 ± 5°C
Operating Temperature	TOP	0	50	°C	1
Storage Temperature	HST	-20	60	°C	1
Operating Ambient Humidity	HOP	10	90	%RH	1
Storage Humidity	HST	10	90	%RH	1

Note : 1. Temperature and relative humidity range are shown in the figure below.  
Wet bulb temperature should be 39°C Max, and no condensation of water.

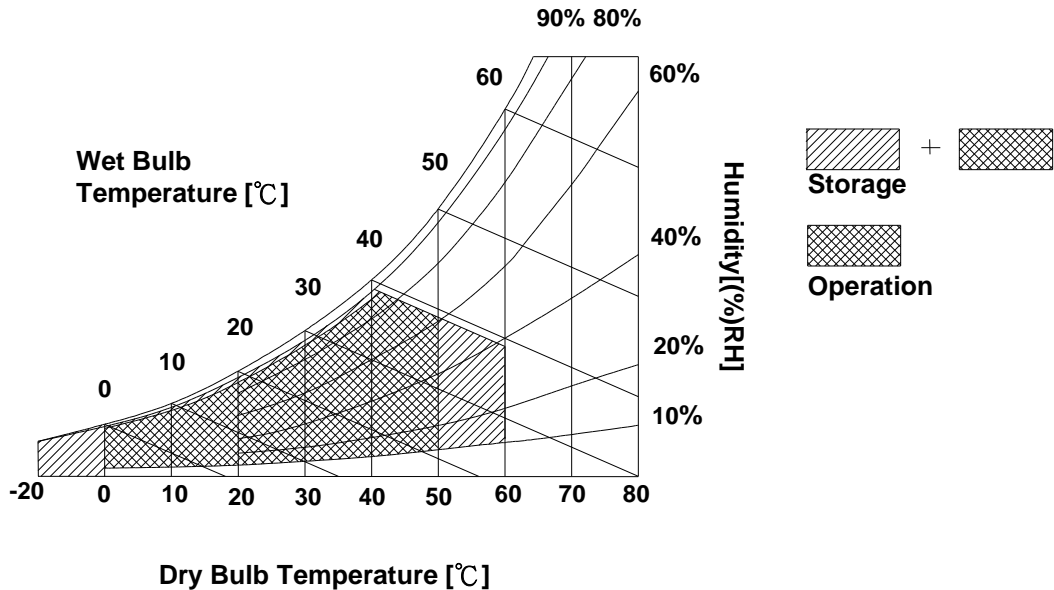

## Product Specification

### 3. Electrical Specifications

#### 3-1. Electrical Characteristics

The LP097X02 requires two power inputs. One is employed to power the LCD electronics and to drive the TFT array and liquid crystal. The second input which powers the LED BL.

**Table 2. ELECTRICAL CHARACTERISTICS**

Parameter	Symbol	Values			Unit	Notes
		Min	Typ	Max		
MODULE :						
Power Supply Input Voltage	VCC	3.0	3.3	3.6	V <sub>DC</sub>	
Power Supply Input Current	I <sub>CC</sub>   Mosaic	-	240	280	mA	1
Power Consumption	P <sub>c</sub>	-	0.8	0.92	Watt	1
Differential Impedance	Z <sub>m</sub>	90	100	110	Ohm	2
LED Backlight :						
(Without LED Driver)						
LED Driver input Volatge (on system)	VLED			12	V	3
Operating Current per string	I <sub>LED</sub>	5	20	25	mA	4
Power Consumption	P <sub>BL</sub>		2.1	2.6	Watt	5
Life Time		10,000	-	-	Hrs	6

Note)

1. The specified current and power consumption are under the V<sub>cc</sub> = 3.3V , 25°C , f<sub>v</sub> = 60Hz condition whereas Mosaic pattern is displayed and f<sub>v</sub> is the frame frequency.

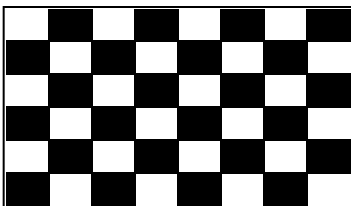

2. This impedance value is needed to proper display and measured form LVDS Tx to the mating connector.
3. **LED input voltage must be input below than 12V to operate normally for LED Driver.**
4. The typical operating current is for the typical surface luminance (L<sub>WH</sub>) in optical characteristics.
5. The LED power consumption shown above does not include power of external LED driver circuit for typical current condition.
6. The life time is determined as the time at which brightness of lamp is 50% compare to that of initial value at the typical lamp current.

## Product Specification

### 3-2. Interface Connections

This LCD employs two interface connections, a 30 pin connector is used for the module electronics interface and the other connector is used for the integral backlight system.

The electronics interface connector is a model 20474-030E-12 manufactured by I-PEX.

**Table 3. MODULE CONNECTOR PIN CONFIGURATION (CN1)**

Pin	Symbol	Description	Notes
1	GND	Ground	[LVDS Receiver] SiliconWorks, SW0627B
2	VCC	Power Supply, 3.3V Typ.	
3	VCC	Power Supply, 3.3V Typ.	[Connector] I-PEX 20474-030E-1#
4	V EEDID	DDC 3.3V power	
5	GSP	GSP	[Mating Connector] I-PEX 20472-030T-10 series or equivalent (micro-coax type)
6	Clk EEDID	DDC Clock	
7	DATA EEDID	DDC Data	[Connector pin arrangement] LCD front view 
8	R <sub>IN</sub> 0-	Negative LVDS differential data input	
9	R <sub>IN</sub> 0+	Positive LVDS differential data input	
10	GND	Ground	
11	R <sub>IN</sub> 1-	Negative LVDS differential data input	
12	R <sub>IN</sub> 1+	Positive LVDS differential data input	
13	GND	Ground	
14	R <sub>IN</sub> 2-	Negative LVDS differential data input	
15	R <sub>IN</sub> 2+	Positive LVDS differential data input	
16	GND	Ground	
17	CLKIN-	Negative LVDS differential clock input	
18	CLKIN+	Positive LVDS differential clock input	
19	GND	Ground	
20	NC	No Connection	
21	Vdc	LED Anode (Positive)	
22	Vdc	LED Anode (Positive)	
23	NC	No Connection	
24	Vdc1	LED Cathode (Negative)	
25	Vdc2	LED Cathode (Negative)	
26	Vdc3	LED Cathode (Negative)	
27	Vdc4	LED Cathode (Negative)	
28	Vdc5	LED Cathode (Negative)	
29	Vdc6	LED Cathode (Negative)	
30	NC	No Connection	

### 3-3. LVDS Signal Timing Specifications

#### 3-3-1. DC Specification

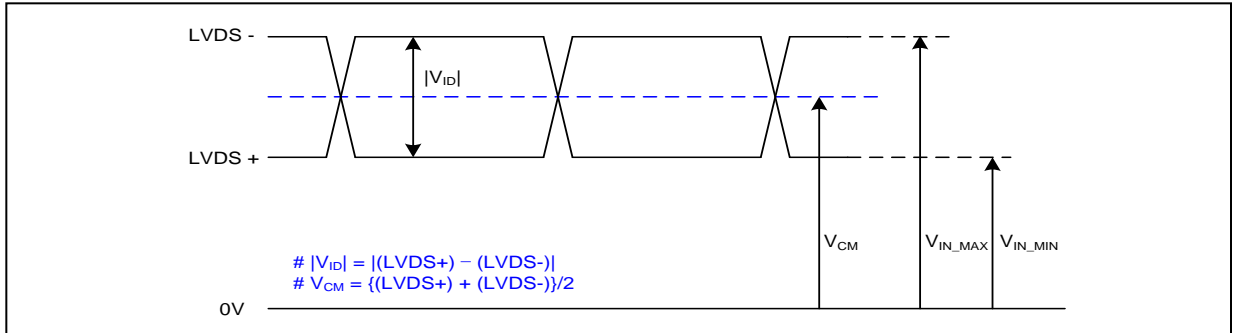

Description	Symbol	Min	Max	Unit	Notes
LVDS Differential Voltage	$ V_{ID} $	100	600	mV	-
LVDS Common mode Voltage	$V_{CM}$	0.6	1.8	V	-
LVDS Input Voltage Range	$V_{IN}$	0.3	2.1	V	-

#### 3-3-2. AC Specification

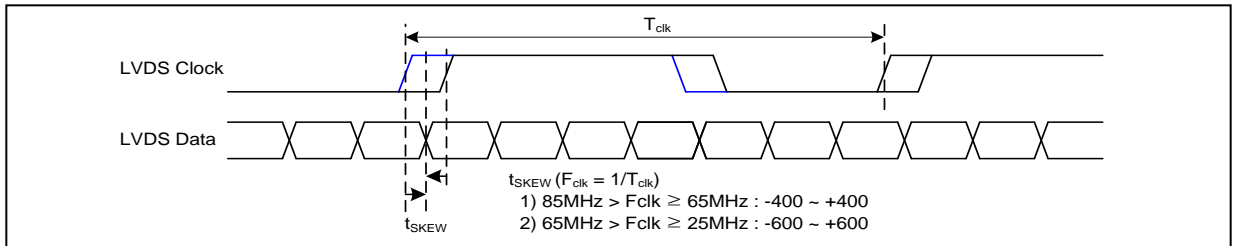

Description	Symbol	Min	Max	Unit	Notes
LVDS Clock to Data Skew Margin	$t_{SKEW}$	- 400	+ 400	ps	$85MHz > F_{clk} \geq 65MHz$
	$t_{SKEW}$	- 600	+ 600	ps	$65MHz > F_{clk} \geq 25MHz$
LVDS Clock to Clock Skew Margin (Even to Odd)	$t_{SKEW\_EO}$	- 1/7	+ 1/7	$T_{clk}$	-
Maximum deviation of input clock frequency during SSC	$F_{DEV}$	-	$\pm 3$	%	-
Maximum modulation frequency of input clock during SSC	$F_{MOD}$	-	200	KHz	-





## Product Specification

### 3-4. Signal Timing Specifications

This is the signal timing required at the input of the User connector. All of the interface signal timing should be satisfied with the following specifications and specifications of LVDS Tx/Rx for its proper operation.

**Table 6. TIMING TABLE**

ITEM	Symbol	Min	Typ	Max	Unit	Note
DCLK	Frequency	$f_{CLK}$	97	100.03	103	MHz
Hsync	Active	$t_{Hp}$	1024	1024	1024	Tclk
	Period	$t_{WH}$	1960	2084	2223	
	Width-Active	$t_{WHA}$	240	320	400	
Vsync	Active	$t_{VP}$	768	768	768	tHP
	Period	$t_{WV}$	776	800	824	
	Width-Active	$t_{WVA}$	3	10	17	
Data Enable	Horizontal back porch	$t_{HBP}$	400	480	560	tCLK
	Horizontal front porch	$t_{HFP}$	180	260	320	
	Vertical back porch	$t_{VBP}$	4	6	12	tHP
	Vertical front porch	$t_{VFP}$	1	16	32	

### 3-5. Signal Timing Waveforms

Condition : VCC = 3.3V

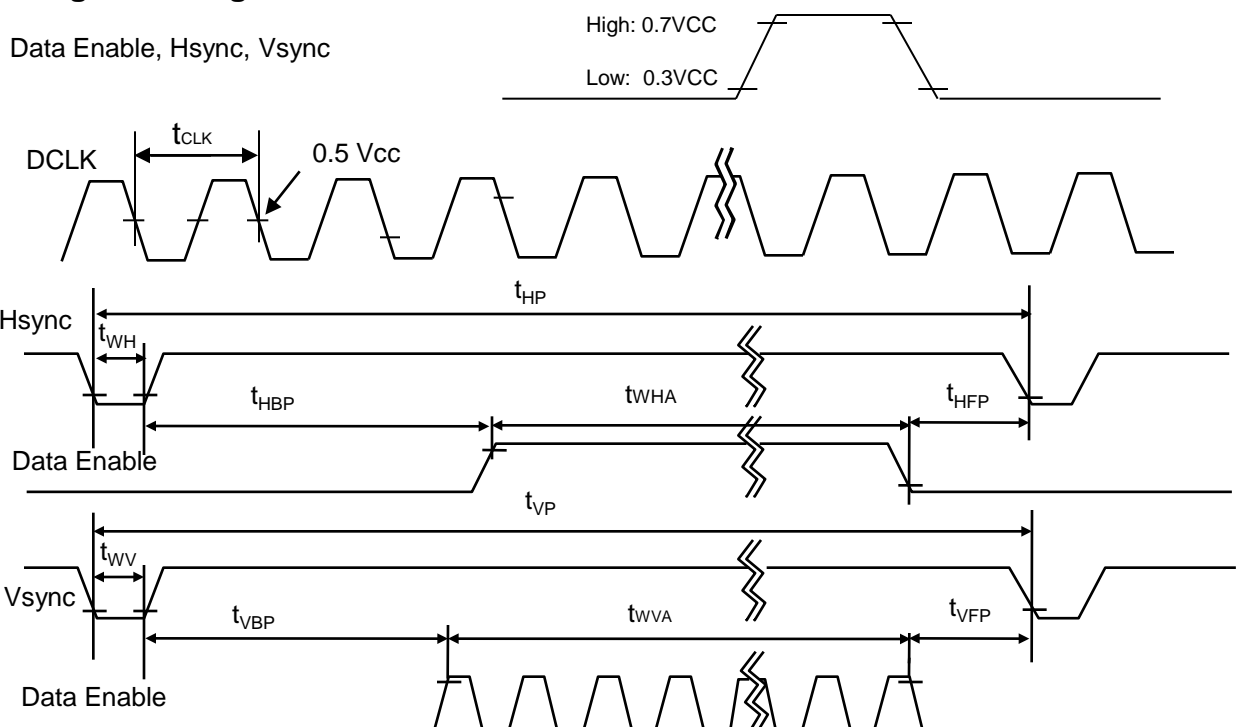

## Product Specification

### 3-6. Color Input Data Reference

The brightness of each primary color (red, green and blue) is based on the 6-bit gray scale data input for the color ; the higher the binary input, the brighter the color. The table below provides a reference for color versus data input.

**Table 7. COLOR DATA REFERENCE**

Color		Input Color Data																	
		RED						GREEN						BLUE					
		MSB			LSB			MSB			LSB			MSB			LSB		
		R5	R4	R3	R2	R1	R0	G5	G4	G3	G2	G1	G0	B5	B4	B3	B2	B1	B0
Basic Color	Black	0	0	0	0	0	0	0	0	0	0	0	0	0	0	0	0	0	0
	Red	1	1	1	1	1	1	0	0	0	0	0	0	0	0	0	0	0	0
	Green	0	0	0	0	0	0	1	1	1	1	1	1	0	0	0	0	0	0
	Blue	0	0	0	0	0	0	0	0	0	0	0	0	1	1	1	1	1	1
	Cyan	0	0	0	0	0	0	1	1	1	1	1	1	1	1	1	1	1	1
	Magenta	1	1	1	1	1	1	0	0	0	0	0	0	1	1	1	1	1	1
	Yellow	1	1	1	1	1	1	1	1	1	1	1	1	0	0	0	0	0	0
	White	1	1	1	1	1	1	1	1	1	1	1	1	1	1	1	1	1	1
RED	RED (00)	0	0	0	0	0	0	0	0	0	0	0	0	0	0	0	0	0	0
	RED (01)	0	0	0	0	0	1	0	0	0	0	0	0	0	0	0	0	0	0
	...	...						...						...					
	RED (62)	1	1	1	1	1	0	0	0	0	0	0	0	0	0	0	0	0	0
	RED (63)	1	1	1	1	1	1	0	0	0	0	0	0	0	0	0	0	0	0
GREEN	GREEN (00)	0	0	0	0	0	0	0	0	0	0	0	0	0	0	0	0	0	0
	GREEN (01)	0	0	0	0	0	0	0	0	0	0	0	1	0	0	0	0	0	0
	...	...						...						...					
	GREEN (62)	0	0	0	0	0	0	1	1	1	1	1	0	0	0	0	0	0	0
	GREEN (63)	0	0	0	0	0	0	1	1	1	1	1	1	0	0	0	0	0	0
BLUE	BLUE (00)	0	0	0	0	0	0	0	0	0	0	0	0	0	0	0	0	0	0
	BLUE (01)	0	0	0	0	0	0	0	0	0	0	0	0	0	0	0	0	0	1
	...	...						...						...					
	BLUE (62)	0	0	0	0	0	0	0	0	0	0	0	0	1	1	1	1	1	0
	BLUE (63)	0	0	0	0	0	0	0	0	0	0	0	0	1	1	1	1	1	1

### 3-7. Power Sequence

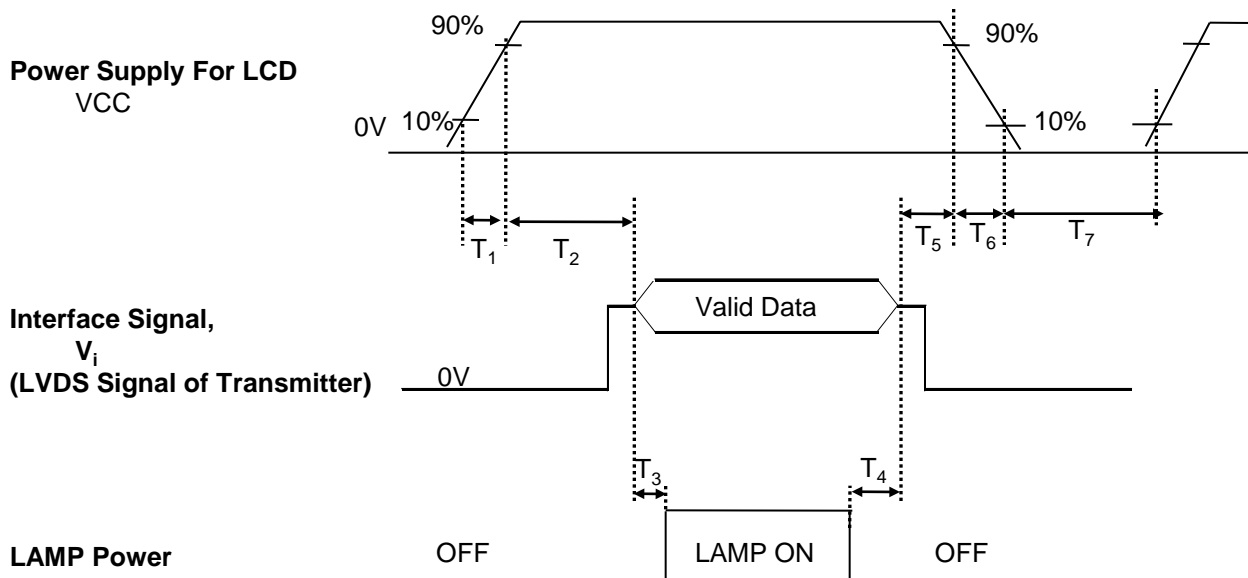

**Table 8. POWER SEQUENCE TABLE**

Parameter	Value			Units
	Min.	Typ.	Max.	
T <sub>1</sub>	0.5	-	10	(ms)
T <sub>2</sub>	0	-	50	(ms)
T <sub>3</sub>	200	-	-	(ms)
T <sub>4</sub>	200	-	-	(ms)
T <sub>5</sub>	0	-	50	(ms)
T <sub>6</sub>	0	-	10	(ms)
T <sub>7</sub>	400	-	-	(ms)

Note)

1. Valid Data is Data to meet “3-3. LVDS Signal Timing Specifications”
2. Please avoid floating state of interface signal at invalid period.
3. When the interface signal is invalid, be sure to pull down the power supply for LCD VCC to 0V.
4. Lamp power must be turn on after power supply for LCD and interface signal are valid.

### 4. Optical Specification

Optical characteristics are determined after the unit has been 'ON' and stable for approximately 20 minutes in a dark environment at 25°C. The values specified are at an approximate distance 50cm from the LCD surface at a viewing angle of  $\phi$  and  $\theta$  equal to 0°.

FIG. 1 presents additional information concerning the measurement equipment and method.

FIG. 1 Optical Characteristic Measurement Equipment and Method

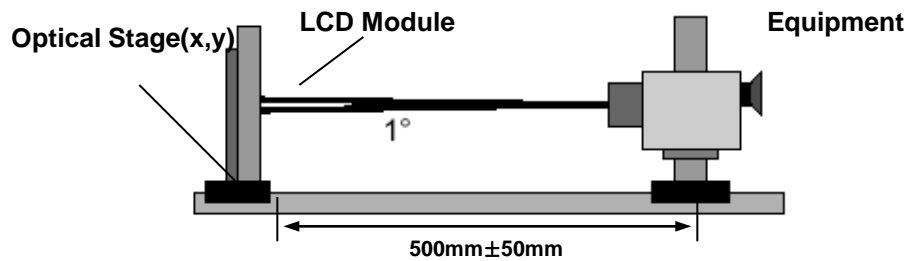

Table 9. OPTICAL CHARACTERISTICS

Ta=25°C, VCC=3.3V, fv=60Hz, fCLK= 100.03MHz, ILED = 20mA

Parameter	Symbol	Condition	Min	Typ	Max	Units	Notes	
Average Luminance	L <sub>AVE</sub>	5 Points (ILED= 20mA)	340	400	-	cd/m <sup>2</sup>	2	
Luminance variation	$\delta_{WHITE}$	13 points	-	1.4	1.6	%	3	
C/R	-	Center 1 Point	500	600	-	-	1	
Response time		-	-	30	50	ms	4	
Viewing angle	Horizontal	$\Theta$	$\phi x(\text{Left,Right})$	±80	±89	-	°	5
	Vertical	$\Theta$	$\phi yu(\text{Up})$	80	89	-		
		$\Theta$	$\phi yd(\text{Down})$	80	89	-		
Color Coordinates	RED	RX	0.574	0.604	0.634			
		RY	0.321	0.351	0.381			
	GREEN	GX	0.291	0.321	0.351			
		GY	0.522	0.552	0.582			
	BLUE	BX	0.122	0.152	0.182			
		BY	0.103	0.133	0.163			
	WHITE	WX	0.283	0.313	0.343			
		WY	0.299	0.329	0.359			
Cross Talk	DSHA	-	-	-	4.0	%	Fig.5	
Gray Scale	-	-	Gamma 2.2				6	

Product Specification

Note)

1. Contrast Ratio(CR) is defined mathematically as  

$$\text{Contrast Ratio} = \frac{\text{Surface Luminance with all white pixels}}{\text{Surface Luminance with all black pixels}}$$

2. Surface luminance is the average of 5 point across the LCD surface 50cm from the surface with all pixels displaying white. For more information see FIG 1.

$$L_{WH} = \text{Average}(L_1, L_2, \dots L_5)$$

3. The variation in surface luminance , The panel total variation ( $\delta_{WHITE}$ ) is determined by measuring  $L_N$  at each test position 1 through 13 and then defined as followed numerical formula.  
For more information see FIG 2.

$$\delta_{WHITE} = \frac{\text{Maximum}(L_1, L_2, \dots L_{13})}{\text{Minimum}(L_1, L_2, \dots L_{13})}$$

4. Response time is the time required for the display to transition from white to black (rise time,  $Tr_R$ ) and from black to white(Decay Time,  $Tr_D$ ). For additional information see FIG 3.
5. Viewing angle is the angle at which the contrast ratio is greater than 10. The angles are determined for the horizontal or x axis and the vertical or y axis with respect to the z axis which is normal to the LCD surface. For more information see FIG 4.

6. Gray scale specification

\*  $f_V = 60\text{Hz}$

Gray Level	Luminance [%] (Typ)
L0	0.12
L7	1.00
L15	4.30
L23	9.80
L31	19.2
L39	34.2
L47	53.5
L55	74.5
L63	100









Product Specification

<REAR VIEW>

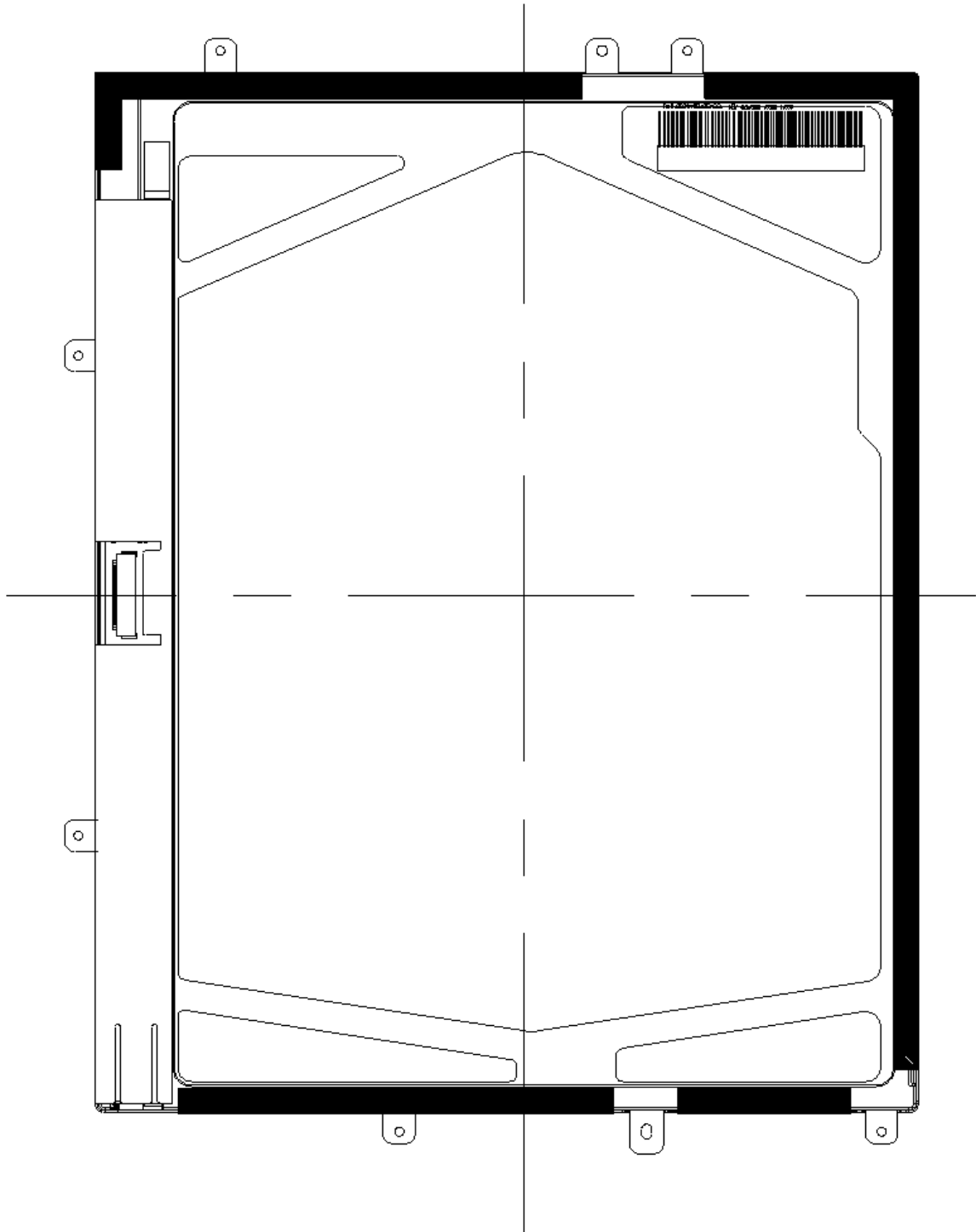

## Product Specification

## 6. Reliability

Environment test condition

No.	Test Item	Conditions
1	High temperature storage test	Ta= 60°C, 240h
2	Low temperature storage test	Ta= -20°C, 240h
3	High temperature operation test	Ta= 50°C, 50%RH, 240h
4	Low temperature operation test	Ta= 0°C, 240h
5	Vibration test (non-operating)	Sine wave, 10 ~ 500 ~ 10Hz, 1.5G, 0.37oct/min 3 axis, 1hour/axis
6	Shock test (non-operating)	Half sine wave, 180G, 2ms one shock of each six faces(I.e. run 180G 6ms for all six faces)
7	Altitude operating storage / shipment	0 ~ 10,000 feet (3,048m) 24Hr 0 ~ 40,000 feet (12,192m) 24Hr

{ Result Evaluation Criteria }

There should be no change which might affect the practical display function when the display quality test is conducted under normal operating condition.

## 7. International Standards

### 7-1. Safety

- a) UL 60950-1:2003, First Edition, Underwriters Laboratories, Inc., Standard for Safety of Information Technology Equipment.
- b) CAN/CSA C22.2, No. 60950-1-03 1<sup>st</sup> Ed. April 1, 2003, Canadian Standards Association, Standard for Safety of Information Technology Equipment.
- c) EN 60950-1:2001, First Edition, European Committee for Electrotechnical Standardization(CENELEC) European Standard for Safety of Information Technology Equipment.

### 7-2. EMC

- a) ANSI C63.4 "Methods of Measurement of Radio-Noise Emissions from Low-Voltage Electrical and Electrical Equipment in the Range of 9kHz to 40GHz. "American National Standards Institute(ANSI), 1992
- b) C.I.S.P.R "Limits and Methods of Measurement of Radio Interface Characteristics of Information Technology Equipment." International Special Committee on Radio Interference.
- c) EN 55022 "Limits and Methods of Measurement of Radio Interface Characteristics of Information Technology Equipment." European Committee for Electrotechnical Standardization.(CENELEC), 1998 ( Including A1: 2000 )

## Product Specification

## 8. Packing

### 8-1. Designation of Lot Mark

a) Lot Mark

A	B	C	D	E	F	G	H	I	J	K	L	M
---	---	---	---	---	---	---	---	---	---	---	---	---

A,B,C : SIZE(INCH)

E : MONTH

D : YEAR

F ~ M : SERIAL NO.

Note

1. YEAR

Year	2001	2002	2003	2004	2005	2006	2007	2008	2009	2010
Mark	1	2	3	4	5	6	7	8	9	0

2. MONTH

Month	Jan	Feb	Mar	Apr	May	Jun	Jul	Aug	Sep	Oct	Nov	Dec
Mark	1	2	3	4	5	6	7	8	9	A	B	C

b) Location of Lot Mark

Serial No. is printed on the label. The label is attached to the backside of the LCD module.  
 This is subject to change without prior notice.

### 8-2. Packing Form

a) Package quantity in one box : 40 pcs

b) Box Size : 365mm × 478mm × 328mm

## 9. PRECAUTIONS

Please pay attention to the followings when you use this TFT LCD module.

### 9-1. MOUNTING PRECAUTIONS

- (1) You must mount a module using holes arranged in four corners or four sides.
- (2) You should consider the mounting structure so that uneven force (ex. Twisted stress) is not applied to the module. And the case on which a module is mounted should have sufficient strength so that external force is not transmitted directly to the module.
- (3) Please attach the surface transparent protective plate to the surface in order to protect the polarizer. Transparent protective plate should have sufficient strength in order to resist external force.
- (4) You should adopt radiation structure to satisfy the temperature specification.
- (5) Acetic acid type and chlorine type materials for the cover case are not desirable because the former generates corrosive gas of attacking the polarizer at high temperature and the latter causes circuit break by electro-chemical reaction.
- (6) Do not touch, push or rub the exposed polarizers with glass, tweezers or anything harder than HB pencil lead. And please do not rub with dust clothes with chemical treatment. Do not touch the surface of polarizer for bare hand or greasy cloth.(Some cosmetics are detrimental to the polarizer.)
- (7) When the surface becomes dusty, please wipe gently with absorbent cotton or other soft materials like chamois soaks with petroleum benzene. Normal-hexane is recommended for cleaning the adhesives used to attach front / rear polarizers. Do not use acetone, toluene and alcohol because they cause chemical damage to the polarizer.
- (8) Wipe off saliva or water drops as soon as possible. Their long time contact with polarizer causes deformations and color fading.
- (9) Do not open the case because inside circuits do not have sufficient strength.

### 9-2. OPERATING PRECAUTIONS

- (1) The spike noise causes the mis-operation of circuits. It should be lower than following voltage :  
 $V = \pm 200\text{mV}$ (Over and under shoot voltage)
- (2) Response time depends on the temperature.(In lower temperature, it becomes longer.)
- (3) Brightness depends on the temperature. (In lower temperature, it becomes lower.)  
And in lower temperature, response time(required time that brightness is stable after turned on) becomes longer.
- (4) Be careful for condensation at sudden temperature change. Condensation makes damage to polarizer or electrical contacted parts. And after fading condensation, smear or spot will occur.
- (5) When fixed patterns are displayed for a long time, remnant image is likely to occur.
- (6) Module has high frequency circuits. Sufficient suppression to the electromagnetic interference shall be done by system manufacturers. Grounding and shielding methods may be important to minimized the interference.

### 9-3. ELECTROSTATIC DISCHARGE CONTROL

Since a module is composed of electronic circuits, it is not strong to electrostatic discharge. Make certain that treatment persons are connected to ground through wrist band etc. And don't touch interface pin directly.

### 9-4. PRECAUTIONS FOR STRONG LIGHT EXPOSURE

Strong light exposure causes degradation of polarizer and color filter.

### 9-5. STORAGE

When storing modules as spares for a long time, the following precautions are necessary.

- (1) Store them in a dark place. Do not expose the module to sunlight or fluorescent light. Keep the temperature between 5°C and 35°C at normal humidity.
- (2) The polarizer surface should not come in contact with any other object.  
It is recommended that they be stored in the container in which they were shipped.

### 9-6. HANDLING PRECAUTIONS FOR PROTECTION FILM

- (1) When the protection film is peeled off, static electricity is generated between the film and polarizer.  
This should be peeled off slowly and carefully by people who are electrically grounded and with well ion-blown equipment or in such a condition, etc.
- (2) The protection film is attached to the polarizer with a small amount of glue. If some stress is applied to rub the protection film against the polarizer during the time you peel off the film, the glue is apt to remain on the polarizer.  
Please carefully peel off the protection film without rubbing it against the polarizer.
- (3) When the module with protection film attached is stored for a long time, sometimes there remains a very small amount of glue still on the polarizer after the protection film is peeled off.
- (4) You can remove the glue easily. When the glue remains on the polarizer surface or its vestige is recognized, please wipe them off with absorbent cotton waste or other soft material like chamois soaked with normal-hexane.

## Product Specification

**APPENDIX A. Enhanced Extended Display Identification Data (EEDID™) 1/3**

Byte# (decimal)	Byte# (HEX)	Field Name and Comments	Value (HEX)	Value (binary)	
0	00	Header	0 0	0000 0000	Header
1	01	Header	F F	1111 1111	
2	02	Header	F F	1111 1111	
3	03	Header	F F	1111 1111	
4	04	Header	F F	1111 1111	
5	05	Header	F F	1111 1111	
6	06	Header	F F	1111 1111	
7	07	Header	0 0	0000 0000	
8	08	EISA manufacture code ( 3 Character ID )	0 6	0000 0110	Vendor/ Product ID
9	09	EISA manufacture code (Compressed ASCII)	1 0	0001 0000	
10	0A	Panel Supplier Reserved - Product Code = K48(0x9cb3)	B 3	1011 0011	
11	0B	( Hex. LSB first )	9 C	1001 1100	
12	0C	LCD Module Serial No - Preferred but Optional (*0* If not used)	0 0	0000 0000	
13	0D	LCD Module Serial No - Preferred but Optional (*0* If not used)	0 0	0000 0000	
14	0E	LCD Module Serial No - Preferred but Optional (*0* If not used)	0 0	0000 0000	
15	0F	LCD Module Serial No - Preferred but Optional (*0* If not used)	0 0	0000 0000	
16	10	Week of Manufacture                      00 weeks	0 0	0000 0000	
17	11	Year of Manufacture                      2009 years	1 3	0001 0011	
18	12	EDID structure version # = 1	0 1	0000 0001	EDID Version/ Revision
19	13	EDID revision # = 3	0 3	0000 0011	
20	14	Video input Definition = Digital signal	8 0	1000 0000	Display Parameter
21	15	Max H image size (Rounded cm) =	1 4	0001 0100	
22	16	Max V image size (Rounded cm) =	0 F	0000 1111	
23	17	Display gamma = (gamma*100)-100 = Example: (2.2*100)-100=120	7 8	0111 1000	
24	18	Feature Support (no_DPMS, no_Active Off/Very Low Power, RGB color display, Timing BLK1, no_GTF)	0 A	0000 1010	
25	19	Red/Green Low Bits (RxBV/GxGv)	0 0	0000 0000	Color Characteristic
26	1A	Blue/White Low Bits (BxBV/WxWv)	0 5	0000 0101	
27	1B	Red X    Rx = 00	0 0	0000 0000	
28	1C	Red Y    Ry = 00	0 0	0000 0000	
29	1D	Green X   Gx = 00	0 0	0000 0000	
30	1E	Green Y   Gy = 00	0 0	0000 0000	
31	1F	Blue X    Bx = 00	0 0	0000 0000	
32	20	Blue Y    By = 00	0 0	0000 0000	
33	21	White X   Wx = 0.313	5 0	0101 0000	
34	22	White Y   Wy = 0.329	5 4	0101 0100	
35	23	Established timing 1 (00h if not used)	0 0	0000 0000	Established Timings
36	24	Established timing 2 (00h if not used)	0 0	0000 0000	
37	25	Manufacturer's timings (00h if not used)	0 0	0000 0000	
38	26	<b>SMP_LMP</b>	<b>A 0</b>	1010 0000	Standard Timing ID
39	27	Panel Vendor ID 0x97	9 7	1001 0111	
40	28	Low Order bits of Project ID_Auto-boot support(1)_Low Order 3 bits of Device Vendor ID	6 9	0110 1001	
41	29	High Order bits of Project ID_LCD Native Color_Black(1)_High Order 3 bits of Device Vendor ID	0 9	0000 1001	
42	2A	0x00	0 0	0000 0000	
43	2B	0x00	0 0	0000 0000	
44	2C	0x00	0 0	0000 0000	
45	2D	0x00	0 0	0000 0000	
46	2E	0x00	0 0	0000 0000	
47	2F	0x00	0 0	0000 0000	
48	30	0x00	0 0	0000 0000	
49	31	0x00	0 0	0000 0000	
50	32	Operating frequency setting (54Mhz =0x36, 100Mhz =0x64)	6 4	0110 0100	
51	33	B/L Configuration(DY:0x, ROE:1x, HS:2x)(TG:x0, Nichia:x1)	1 0	0001 0000	
52	34	0x00	0 0	0000 0000	
53	35	0x00	0 0	0000 0000	



## Product Specification

**APPENDIX A. Enhanced Extended Display Identification Data (EEDID™) 2/3**

Byte# (decimal)	Byte# (HEX)	Field Name and Comments	Value (HEX)	Value (binary)		
54	36	Pixel Clock/10,000 (LSB) : 100Mhz	1 3	0001 0011	Timing Descriptor #1	
55	37	Pixel Clock/10,000 (MSB)	2 7	0010 0111		
56	38	Horizontal Active (lower 8 bits) 1024pixel	0 0	0000 0000		
57	39	Horizontal Blanking(Thp+HA) (lower 8 bits) 1060pixel	2 4	0010 0100		
58	3A	Horizontal Active / Horizontal Blanking(Thp+HA) (upper 4:4bits)	4 4	0100 0100		
59	3B	Vertical Active 768line	0 0	0000 0000		
60	3C	Vertical Blanking (Tvp+HA) (DE Blanking typ for DE only panels) 32line	2 0	0010 0000		
61	3D	Vertical Active : Vertical Blanking (Tvp+HA) (upper 4:4bits)	3 0	0011 0000		
62	3E	Horizontal Sync. Offset (Thfp) 260pixel	0 4	0000 0100		
63	3F	Horizontal Sync Pulse Width (HSPW) 320pixel	4 0	0100 0000		
64	40	Horizontal Sync Offset (Tvp) : Sync Width (VSPW) 16line/10line	0 A	0000 1010		
65	41	Horizontal Vertical Sync Offset/Width (upper 2bits)	5 4	0101 0100		
66	42	Horizontal Image Size (mm)	C 5	1100 0101		
67	43	Vertical Image Size (mm)	9 4	1001 0100		
68	44	Horizontal Image Size / Vertical Image Size	0 0	0000 0000		
69	45	Horizontal Border = 0 (Zero for Notebook LCD)	0 0	0000 0000		
70	46	Vertical Border = 0 (Zero for Notebook LCD)	0 0	0000 0000		
71	47	Non-Interface, Normal display, no stereo, Digital Separate ( Vsync_NEG, Hsync_NEG )	1 8	0001 1000		
72	48	Flag	0 0	0000 0000		Timing Description #2
73	49	Flag	0 0	0000 0000		
74	4A	Flag	0 0	0000 0000		
75	4B	Data Type Tag (Descriptor Defined by manufacturer)	0 1	0000 0001		
76	4C	Flag	0 0	0000 0000		
77	4D	Descriptor Defined by manufacturer (Apple EDID signature)	0 6	0000 0110		
78	4E	Descriptor Defined by manufacturer (Apple EDID signature)	1 0	0001 0000		
79	4F	Descriptor Defined by manufacturer (Link Type)	3 0	0011 0000		
80	50	Descriptor Defined by manufacturer (Pixel and link component format_6bit panel interface)	0 0	0000 0000		
81	51	Descriptor Defined by manufacturer (Panel feature_Inverter NA, no Inverter)	0 0	0000 0000		
82	52	Descriptor Defined by manufacturer	0 0	0000 0000		
83	53	Descriptor Defined by manufacturer	0 0	0000 0000		
84	54	Descriptor Defined by manufacturer	0 0	0000 0000		
85	55	Descriptor Defined by manufacturer	0 0	0000 0000		
86	56	Descriptor Defined by manufacturer	0 0	0000 0000		
87	57	Descriptor Defined by manufacturer	0 0	0000 0000		
88	58	(If<13 char--> 0Ah, then terminate with ASCII code 0Ah,set remaining char = 20h)	0 A	0000 1010		
89	59	(If<13 char--> 0Ah, then terminate with ASCII code 0Ah,set remaining char = 20h)	2 0	0010 0000		
90	5A	Flag	0 0	0000 0000	Timing Description #3	
91	5B	Flag	0 0	0000 0000		
92	5C	Flag	0 0	0000 0000		
93	5D	Data Type Tag ( ASCII String )	F E	1111 1110		
94	5E	Flag	0 0	0000 0000		
95	5F	L	4 C	0100 1100		
96	60	P	5 0	0101 0000		
97	61	0	3 0	0011 0000		
98	62	9	3 9	0011 1001		
99	63	7	3 7	0011 0111		
100	64	X	5 8	0101 1000		
101	65	0	3 0	0011 0000		
102	66	2	3 2	0011 0010		
103	67	-	2 D	0010 1101		
104	68	S	5 3	0101 0011		
105	69	L	4 C	0100 1100		
106	6A	A	4 1	0100 0001		
107	6B	2	3 2	0011 0010		

Product Specification

**APPENDIX A. Enhanced Extended Display Identification Data (EEDID™) 3/3**

Byte# (decimal)	Byte# (HEX)	Field Name and Comments	Value (HEX)	Value (binary)	
108	6C	Flag	0 0	0000 0000	Timing Description #4
109	6D	Flag	0 0	0000 0000	
110	6E	Flag	0 0	0000 0000	
111	6F	Data Type Tag ( ASCII String )	F E	1111 1110	
112	70	Flag	0 0	0000 0000	
113	71	C	4 3	0100 0011	
114	72	o	6 E	0110 1111	
115	73	l	6 C	0110 1100	
116	74	o	6 F	0110 1111	
117	75	r	7 2	0111 0010	
118	76	SPACE	2 0	0010 0000	
119	77	L	4 C	0100 1100	
120	78	C	4 3	0100 0011	
121	79	D	4 4	0100 0100	
122	7A	LE	0 A	0000 1010	
123	7B	SPACE	2 0	0010 0000	
124	7C	SPACE	2 0	0010 0000	
125	7D	SPACE	2 0	0010 0000	
126	7E	Extension flag (# of optional 128 panel ID extension block to follow, Typ = 0)	0 0	0000 0000	Extension Flag
127	7F	Check Sum (The 1-byte sum of all 128 bytes in this panel ID block shall = 0)	9 C	1001 1100	Checksum