



## 24N50

Power MOSFET

### 24A, 500V N-CHANNEL POWER MOSFET

#### DESCRIPTION

The UTC **24N50** is an N-channel mode power MOSFET using UTC's advanced technology to provide customers with planar stripe and DMOS technology. This technology allows a minimum on-state resistance and superior switching performance. It also can withstand high energy pulse in the avalanche and commutation mode.

The UTC **24N50** is generally applied in high efficiency switch mode power supplies, active power factor correction and electronic lamp ballasts based on half bridge topology.

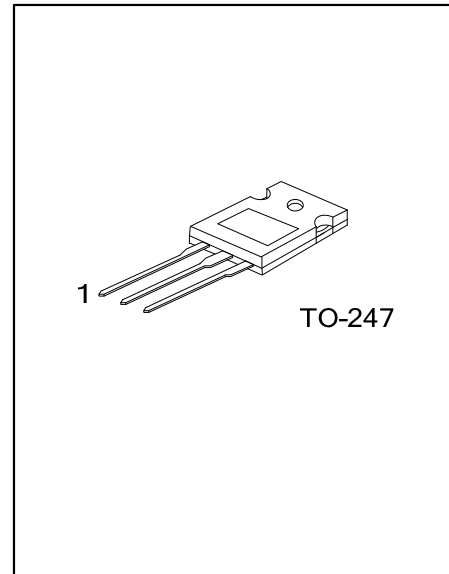

#### FEATURES

- \*  $R_{DS(ON)}=0.24\Omega @ V_{GS}=10V$
- \* High Switching Speed
- \* 100% Avalanche Tested

#### SYMBOL

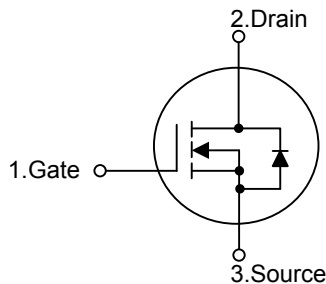

#### ORDERING INFORMATION

Ordering Number		Package	Pin Assignment			Packing
Lead Free	Halogen Free		1	2	3	
24N50L-T47-T	24N50G-T47-T	TO-247	G	D	S	Tube

Note: Pin Assignment: G: Gate D: Drain S: Source

<p>24N50L-T47-T</p> <ul style="list-style-type: none"> <li>(1) Packing Type</li> <li>(2) Package Type</li> <li>(3) Lead Free</li> </ul>	<ul style="list-style-type: none"> <li>(1) T: Tube</li> <li>(2) T47: TO-247</li> <li>(3) G: Halogen Free, L: Lead Free</li> </ul>
---	---

■ ABSOLUTE MAXIMUM RATINGS ( $T_c=25^\circ\text{C}$ , unless otherwise specified)

PARAMETER		SYMBOL	RATINGS	UNIT
Drain-Source Voltage		$V_{DSS}$	500	V
Gate-Source Voltage		$V_{GSS}$	$\pm 30$	V
Drain Current	Continuous ( $T_c=25^\circ\text{C}$ )	$I_D$	24 (Note 2)	A
	Pulsed (Note 3)	$I_{DM}$	96 (Note 2)	A
Avalanche Current (Note 3)		$I_{AR}$	24	A
Avalanche Energy	Single Pulsed (Note 4)	$E_{AS}$	1100	mJ
	Repetitive (Note 5)	$E_{AR}$	29	mJ
Peak Diode Recovery dv/dt (Note 5)		dv/dt	15	V/ns
Power Dissipation		$P_D$	290	W
Derate above $25^\circ\text{C}$			2.33	W/ $^\circ\text{C}$
Junction Temperature		$T_J$	+150	$^\circ\text{C}$
Storage Temperature		$T_{STG}$	-55~+150	$^\circ\text{C}$

Note: 1. Absolute maximum ratings are those values beyond which the device could be permanently damaged.

Absolute maximum ratings are stress ratings only and functional device operation is not implied.

2. Drain current limited by maximum junction temperature
3. Repetitive Rating: Pulse width limited by maximum junction temperature
4.  $L = 3.4\text{mH}$ ,  $I_{AS} = 24\text{A}$ ,  $V_{DD} = 50\text{V}$ ,  $R_G = 25\Omega$ , Starting  $T_J = 25^\circ\text{C}$
5.  $I_{SD} \leq 24\text{A}$ ,  $di/dt \leq 200\text{A}/\mu\text{s}$ ,  $V_{DD} \leq BV_{DSS}$ , Starting  $T_J = 25^\circ\text{C}$

■ THERMAL DATA

PARAMETER	SYMBOL	RATINGS	UNIT
Junction to Ambient	$\theta_{JA}$	40	$^\circ\text{C}/\text{W}$
Junction to Case	$\theta_{JC}$	0.43	$^\circ\text{C}/\text{W}$

■ ELECTRICAL CHARACTERISTICS ( $T_c=25^\circ\text{C}$ , unless otherwise specified)

PARAMETER	SYMBOL	TEST CONDITIONS	MIN	TYP	MAX	UNIT
<b>OFF CHARACTERISTICS</b>						
Drain-Source Breakdown Voltage	$BV_{DSS}$	$I_D=250\mu\text{A}$ , $V_{GS}=0\text{V}$	500			V
Drain-Source Leakage Current	$I_{DSS}$	$V_{DS}=500\text{V}$ , $V_{GS}=0\text{V}$			50	$\mu\text{A}$
Gate- Source Leakage Current	$I_{GSS}$	Forward			+100	nA
		Reverse			-100	nA
<b>ON CHARACTERISTICS</b>						
Gate Threshold Voltage	$V_{GS(TH)}$	$V_{DS}=V_{GS}$ , $I_D=250\mu\text{A}$	2.0		4.0	V
Static Drain-Source On-State Resistance	$R_{DS(ON)}$	$V_{GS}=10\text{V}$ , $I_D=12\text{A}$		0.15	0.24	$\Omega$
<b>DYNAMIC PARAMETERS</b>						
Input Capacitance	$C_{ISS}$	$V_{GS}=0\text{V}$ , $V_{DS}=25\text{V}$ , $f=1.0\text{MHz}$		3500	4500	pF
Output Capacitance	$C_{OSS}$			520	670	pF
Reverse Transfer Capacitance	$C_{RSS}$			55	70	pF

■ ELECTRICAL CHARACTERISTICS(Cont.)

PARAMETER	SYMBOL	TEST CONDITIONS	MIN	TYP	MAX	UNIT
<b>SWITCHING PARAMETERS</b>						
Total Gate Charge	$Q_G$	$V_{GS}=10V, V_{DS}=400V, I_D=24A$ (Note 1, 2)		90	120	nC
Gate to Source Charge	$Q_{GS}$			23		nC
Gate to Drain Charge	$Q_{GD}$			52		nC
Turn-ON Delay Time	$t_{D(ON)}$	$V_{DD}=250V, I_D=24A, R_G=25\Omega$ (Note 1, 2)		80	170	ns
Rise Time	$t_R$			250	500	ns
Turn-OFF Delay Time	$t_{D(OFF)}$			200	400	ns
Fall-Time	$t_F$			155	320	ns
<b>SOURCE- DRAIN DIODE RATINGS AND CHARACTERISTICS</b>						
Maximum Body-Diode Continuous Current	$I_S$				24	A
Maximum Body-Diode Pulsed Current	$I_{SM}$				96	A
Drain-Source Diode Forward Voltage	$V_{SD}$	$I_S=24A, V_{GS}=0V$			1.4	V
Body Diode Reverse Recovery Time	$t_{rr}$	$I_S=24A, V_{GS}=0V,$ $dI_F/dt=100A/\mu s$ (Note 1)		250		ns
Body Diode Reverse Recovery Charge	$Q_{RR}$			1.1		$\mu C$

Note: 1. Pulse Test: Pulse width  $\leq 300\mu s$ , Duty cycle  $\leq 2\%$   
 2. Essentially independent of operating temperature

## TEST CIRCUITS AND WAVEFORMS

Gate Charge Test Circuit

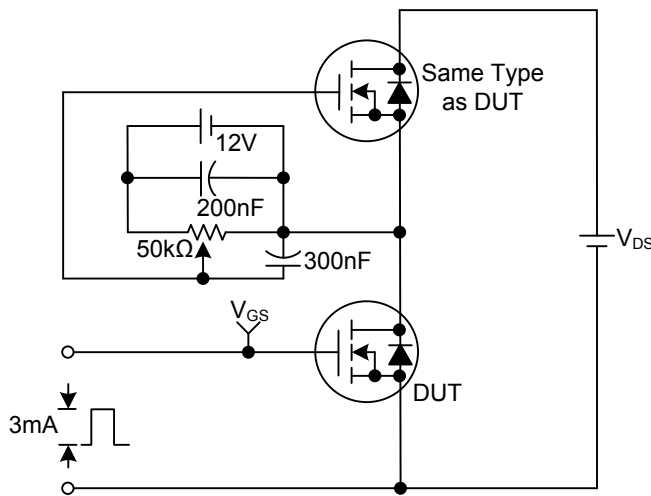

Gate Charge Waveforms

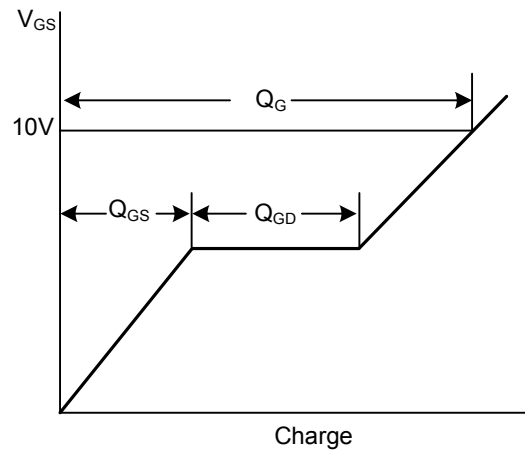

Resistive Switching Test Circuit

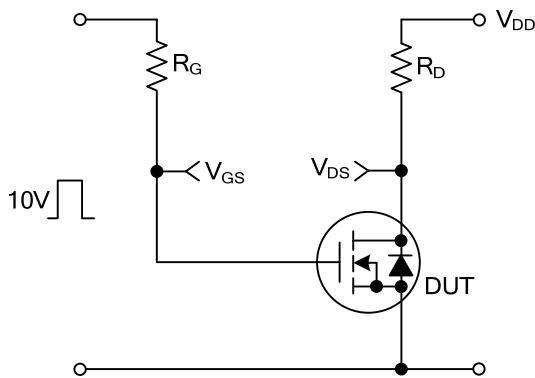

Resistive Switching Waveforms

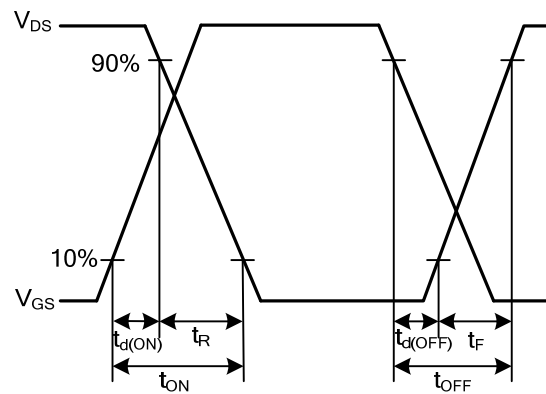

Unclamped Inductive Switching Test Circuit

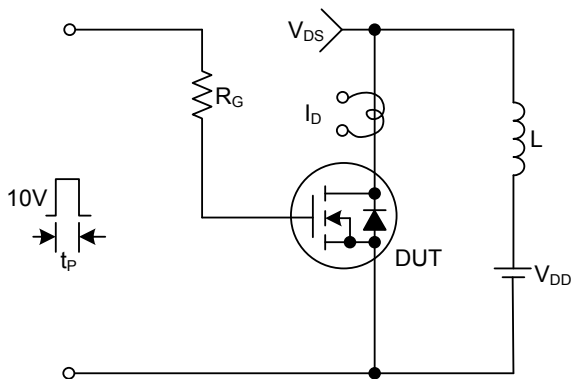

Unclamped Inductive Switching Waveforms

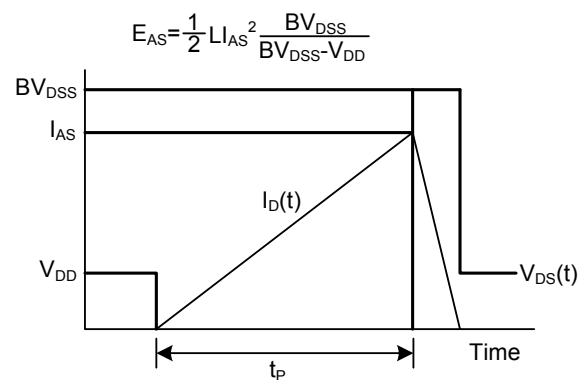

■ TEST CIRCUITS AND WAVEFORMS(Cont.)

Peak Diode Recovery dv/dt Test Circuit & Waveforms

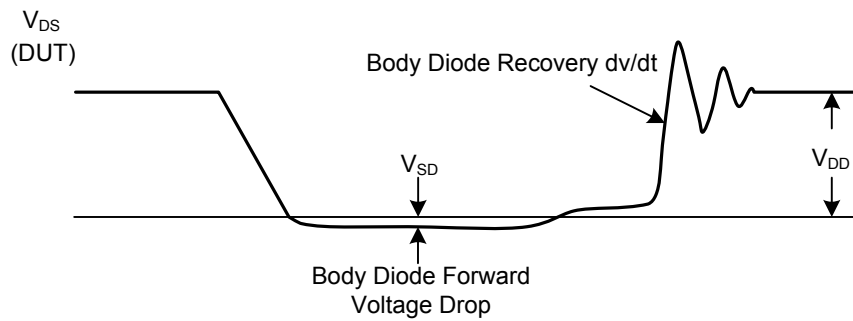
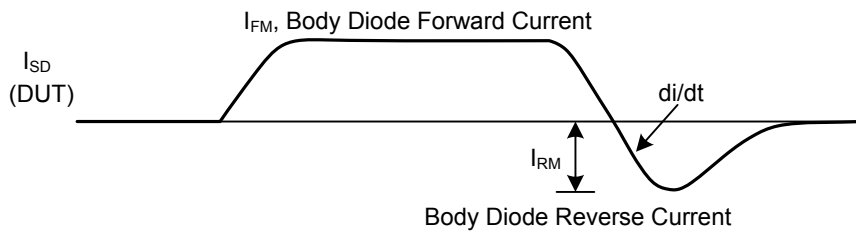
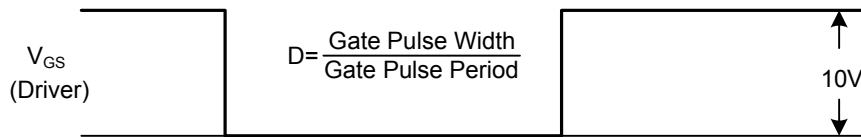
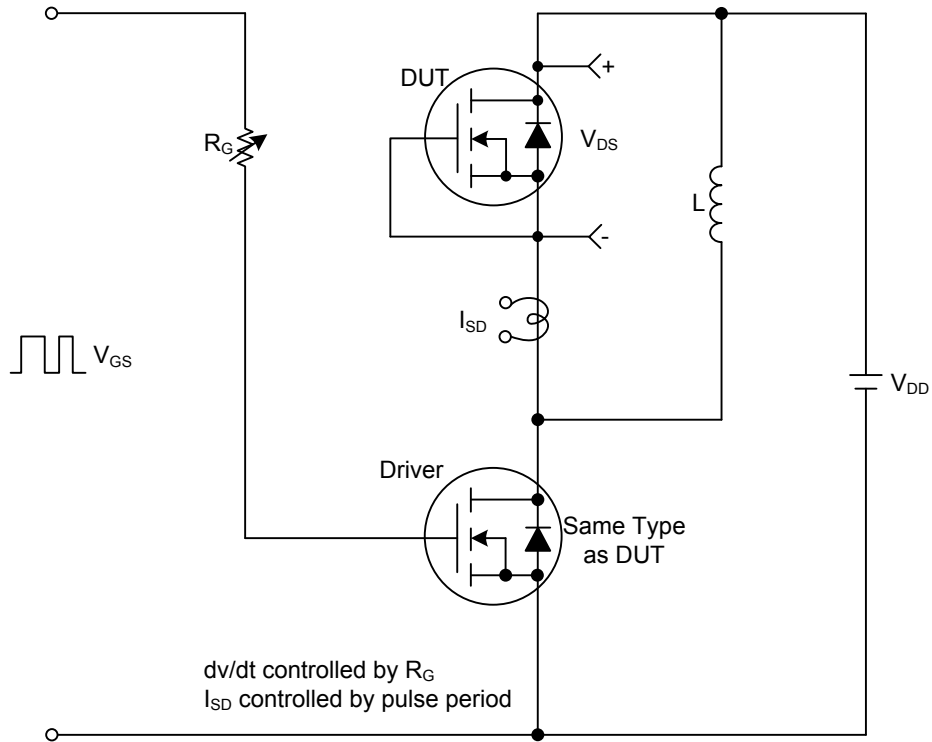

## TYPICAL CHARACTERISTICS

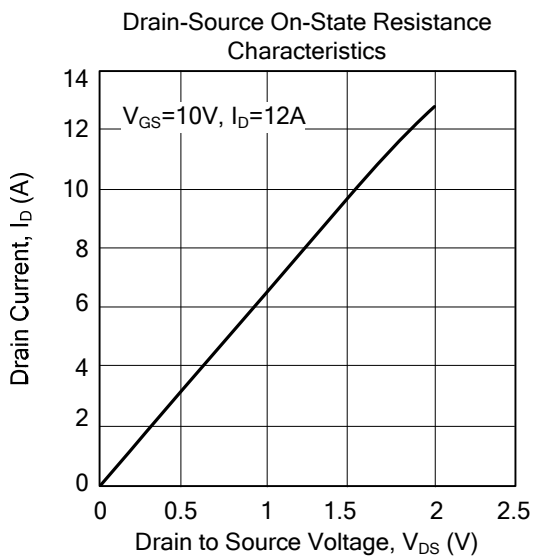
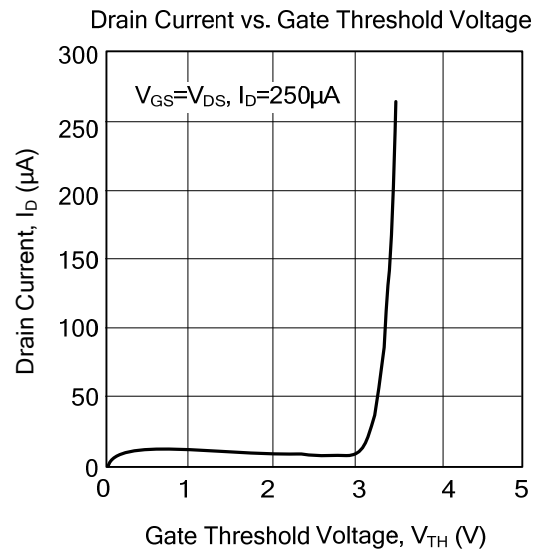
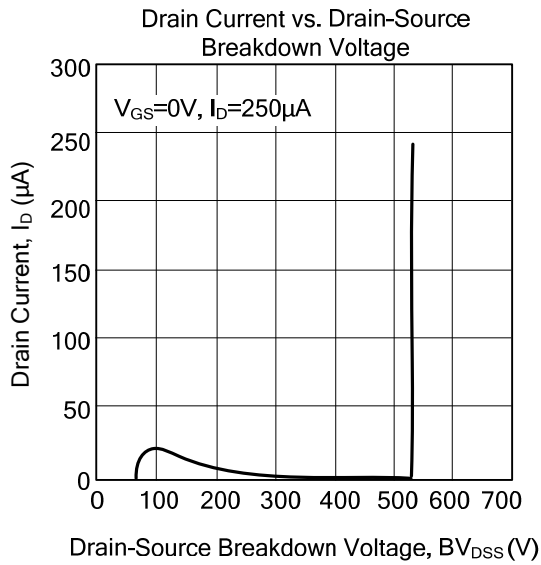

UTC assumes no responsibility for equipment failures that result from using products at values that exceed, even momentarily, rated values (such as maximum ratings, operating condition ranges, or other parameters) listed in products specifications of any and all UTC products described or contained herein. UTC products are not designed for use in life support appliances, devices or systems where malfunction of these products can be reasonably expected to result in personal injury. Reproduction in whole or in part is prohibited without the prior written consent of the copyright owner. The information presented in this document does not form part of any quotation or contract, is believed to be accurate and reliable and may be changed without notice.