

# Full-Featured LED Driver with 2.3A Switch Current

## FEATURES

- 3000:1 True Color PWM™ Dimming Ratio
- 2.3A, 45V Internal Switch
- 100mV High Side Current Sense
- Open LED Protection
- Adjustable Frequency: 250kHz to 2.5MHz
- Wide Input Voltage Range:  
   Operation from 3V to 30V  
   Transient Protection to 40V
- Operates in Boost, Buck Mode and Buck-Boost Mode
- Gate Driver for PMOS LED Disconnect
- Constant-Current and Constant-Voltage Regulation
- CTRL Pin Provides 10:1 Analog Dimming
- Low Shutdown Current: <1μA
- Available in (4mm × 4mm) 16-Lead QFN and 16-Pin TSSOP Packages

## APPLICATIONS

- Display Backlighting
- Automotive and Avionic Lighting
- Illumination
- Scanners

## DESCRIPTION

The LT<sup>®</sup>3518 is a current mode DC/DC converter with an internal 2.3A, 45V switch specifically designed to drive LEDs. The LT3518 operates as a LED driver in boost, buck mode and buck-boost mode. It combines a traditional voltage loop and a unique current loop to operate as a constant-current source or constant-voltage source. Programmable switching frequency allows optimization of the external components for efficiency or component size. The switching frequency of the LT3518 can be synchronized to an external clock signal. The LED current is externally programmable with a 100mV sense resistor. The external PWM input provides 3000:1 LED dimming. The CTRL pin provides further 10:1 dimming ratio.

The LT3518 is available in the tiny footprint 16-lead QFN (4mm×4mm) and the 16-pin TSSOP package. The LT3518 provides a complete solution for both constant-voltage and constant-current applications.

LT, LT, LTC and LTM are registered trademarks of Linear Technology Corporation. True Color PWM is a trademark of Linear Technology Corporation. Patent Pending. All other trademarks are the property of their respective owners. Protected by U.S. Patents, including 7199560, 7321203, 7746300.

## TYPICAL APPLICATION

1.5A Buck Mode LED Driver

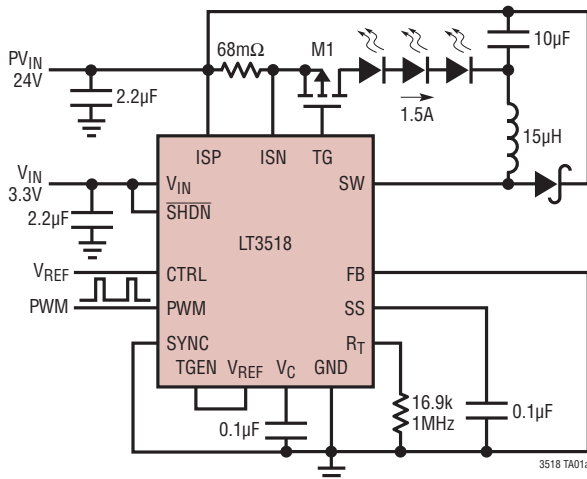

Efficiency

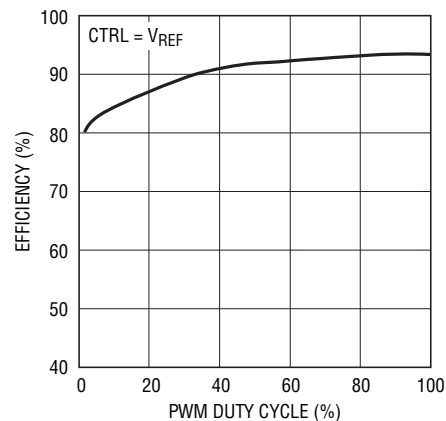

3518 TA01b

# LT3518

## ABSOLUTE MAXIMUM RATINGS (Note 1)

$V_{IN}$ , $\overline{SHDN}$ , PWM, TGEN (Note 3).....	40V	Storage Temperature Range	
SW, ISP, ISN, TG.....	45V	QFN.....	-65°C to 125°C
TG Pin Below ISP Pin.....	10V	TSSOP.....	-65°C to 150°C
FB, SYNC, SS, CTRL.....	6V	Lead Temperature (Soldering, 10 sec)	
$V_C$ , $R_T$ , $V_{REF}$ .....	3V	TSSOP.....	300°C
Operating Junction Temperature Range (Notes 2, 4)			
LT3518E.....	-40°C to 125°C		
LT3518I.....	-40°C to 125°C		
LT3518H.....	-40°C to 150°C		

## PIN CONFIGURATION

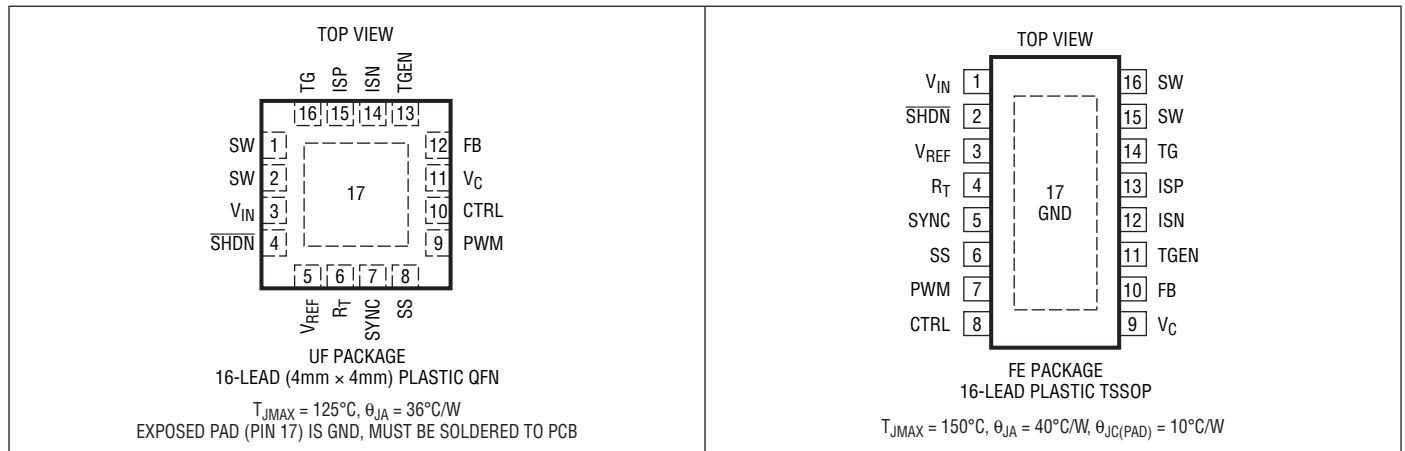

## ORDER INFORMATION

LEAD FREE FINISH	TAPE AND REEL	PART MARKING*	PACKAGE DESCRIPTION	TEMPERATURE RANGE
LT3518EUF#PBF	LT3518EUF#TRPBF	3518	16-Lead (4mm × 4mm) Plastic QFN	-40°C to 125°C
LT3518IUF#PBF	LT3518IUF#TRPBF	3518	16-Lead (4mm × 4mm) Plastic QFN	-40°C to 125°C
LT3518EFE#PBF	LT3518EFE#TRPBF	3518FE	16-Lead Plastic TSSOP	-40°C to 125°C
LT3518IFE#PBF	LT3518IFE#TRPBF	3518FE	16-Lead Plastic TSSOP	-40°C to 125°C
LT3518HFE#PBF	LT3518HFE#TRPBF	3518FE	16-Lead Plastic TSSOP	-40°C to 150°C

Consult LTC Marketing for parts specified with wider operating temperature ranges. \*The temperature grade is identified by a label on the shipping container. Consult LTC Marketing for information on non-standard lead based finish parts.

For more information on lead free part marking, go to: <http://www.linear.com/leadfree/>

For more information on tape and reel specifications, go to: <http://www.linear.com/tapeandree/>

**ELECTRICAL CHARACTERISTICS** The ● denotes the specifications which apply over the full operating temperature range, otherwise specifications are at  $T_A = 25^\circ\text{C}$ . (Note 2)  $V_{IN} = 5\text{V}$ ,  $\overline{\text{SHDN}} = 5\text{V}$ ,  $\text{PWM} = 5\text{V}$  unless otherwise noted.

PARAMETER	CONDITIONS		MIN	TYP	MAX	UNITS
Minimum $V_{IN}$ Operating Voltage					3	V
Maximum $V_{IN}$ Operating Voltage	Continuous Operation (Note 3)		30			V
Current Sense Voltage ( $V_{ISP} - V_{ISN}$ )	$V_{CTRL} = 2\text{V}$ , $V_{ISP} = 24\text{V}$ , $V_C = 1\text{V}$ $V_{CTRL} = 2\text{V}$ , $V_{ISP} = 0\text{V}$ , $V_C = 1\text{V}$	●	96	100 100	103	mV mV
10% Scale Current Sense Voltage ( $V_{ISP} - V_{ISN}$ )	$V_{CTRL} = 100\text{mV}$ , $V_{ISP} = 24\text{V}$ , $V_C = 1\text{V}$			9		mV
Current Sense Voltage Line Regulation	$2\text{V} < V_{ISP} < 45\text{V}$			0.03		%/V
$V_{IN}$ Supply Current	$\text{PWM} > 1.5\text{V}$ , $V_C = 0\text{V}$ $\text{PWM} = 0\text{V}$ $\overline{\text{SHDN}} = 0\text{V}$			6 4.5 0.1	10 1	mA mA $\mu\text{A}$
Switching Frequency	$R_T = 16.7\text{k}$ $R_T = 4.03\text{k}$ $R_T = 91.5\text{k}$	●	0.85 2.25 220	1.0 2.5 250	1.15 2.7 270	MHz MHz kHz
$R_T$ Voltage				1		V
Soft-Start Pin Current	$\text{SS} = 0.5\text{V}$ , Out of Pin		6	9	12	$\mu\text{A}$
SYNC Pull-Down Current (Into the Pin)	$V_{\text{SYNC}} = 2\text{V}$			60		$\mu\text{A}$
SYNC Input Low					0.4	V
SYNC Input High			1.5			V
Maximum Duty Cycle	$R_T = 91.5\text{k}$ (250kHz) SYNC = 300kHz Clock Signal, $R_T = 91.5\text{k}$ $R_T = 16.7\text{k}$ (1MHz) $R_T = 4.03\text{k}$ (2.5MHz)	●	95 94 85	97 96 90 74		% % % %
Switch Current Limit			2.3	2.8	3.5	A
Switch $V_{\text{CESAT}}$	$I_{\text{SW}} = 1.5\text{A}$			400		mV
Switch Leakage Current	$V_{\text{SW}} = 45\text{V}$ , $\text{PWM} = 0\text{V}$				2	$\mu\text{A}$
CTRL Input Bias Current	Current Out of Pin, $V_{\text{CTRL}} = 0.1\text{V}$			20	100	nA
Error Amplifier Transconductance				550		$\mu\text{S}$
$V_C$ Output Impedance				1000		$\text{k}\Omega$
$V_C$ Idle Input Bias Current	$\text{PWM} = 0$ , $V_C = 1\text{V}$		-20	0	20	nA
FB Pin Input Bias Current	Current Out of Pin, $V_{\text{FB}} = 0.5\text{V}$			20	100	nA
FB Pin Threshold		●	0.98	1.01	1.04	V
ISP, ISN Idle Input Bias Current	$\text{PWM} = 0\text{V}$				300	nA
ISP, ISN Full-Scale Input Bias Current	ISP Tied to ISN, $V_{\text{ISP}} = 24\text{V}$ , $V_{\text{CTRL}} = 2\text{V}$			20		$\mu\text{A}$
$\overline{\text{SHDN}}$ Voltage High		●	1.2			V
$\overline{\text{SHDN}}$ Voltage Low	$-40^\circ\text{C} \leq T_J \leq 125^\circ\text{C}$ $125^\circ\text{C} < T_J \leq 150^\circ\text{C}$				0.45 0.40	V V
$\overline{\text{SHDN}}$ Pin Bias Current				60	100	$\mu\text{A}$
PWM Input High Voltage		●	1.2			V
PWM Input Low Voltage	$-40^\circ\text{C} \leq T_J \leq 125^\circ\text{C}$ $125^\circ\text{C} < T_J \leq 150^\circ\text{C}$				0.45 0.40	V V
PWM Pin Bias Current				60	120	$\mu\text{A}$

## ELECTRICAL CHARACTERISTICS

The ● denotes the specifications which apply over the full operating temperature range, otherwise specifications are at  $T_A = 25^\circ\text{C}$ . (Note 2)  $V_{IN} = 5\text{V}$ ,  $\overline{\text{SHDN}} = 5\text{V}$ ,  $\text{PWM} = 5\text{V}$  unless otherwise noted.

PARAMETER	CONDITIONS	MIN	TYP	MAX	UNITS
TGEN Input High Voltage		1.5			V
TGEN Input Low Voltage				0.4	V
TGEN Pin Bias Current	TGEN = 5V		100	200	$\mu\text{A}$
$V_{\text{REF}}$ Pin Voltage	$I_{\text{REF}} = -100\mu\text{A}$	● 1.96	2	2.04	V
$V_{\text{REF}}$ Pin Voltage Line Regulation	$3\text{V} < V_{\text{IN}} < 40\text{V}$			0.03	%/V
Gate Turn-On Delay	$C_{\text{LOAD}} = 1\text{nF}$ Between ISP and TG		200		ns
Gate Turn-Off Delay	$C_{\text{LOAD}} = 1\text{nF}$ Between ISP and TG		200		ns
Top Gate Drive $V_{\text{GS}}$ ( $V_{\text{ISP}} - V_{\text{TG}}$ )	$V_{\text{ISP}} = 24\text{V}$ , TGEN = 5V PWM = 0V		7 0	0.3	V V

**Note 1:** Stresses beyond those listed under Absolute Maximum Ratings may cause permanent damage to the device. Exposure to any Absolute Maximum Rating condition for extended periods may affect device reliability and lifetime.

**Note 2:** The LT3518E is guaranteed to meet performance specifications from  $0^\circ\text{C}$  to  $125^\circ\text{C}$  junction temperature. Specifications over the  $-40^\circ\text{C}$  to  $125^\circ\text{C}$  operating junction temperature range are assured by design, characterization and correlation with statistical process controls. The LT3518I is guaranteed over the full  $-40^\circ\text{C}$  to  $125^\circ\text{C}$  operating junction temperature range. The LT3518H is guaranteed over the full  $-40^\circ\text{C}$  to  $150^\circ\text{C}$  operating junction temperature range. Operating lifetime is derated at junction temperatures greater than  $125^\circ\text{C}$ .

**Note 3:** Absolute maximum voltage at  $V_{\text{IN}}$ ,  $\overline{\text{SHDN}}$ , PWM and TGEN pins is 40V for nonrepetitive 1 second transients and 30V for continuous operation.

**Note 4:** This IC includes overtemperature protection that is intended to protect the device during momentary overload conditions. Junction temperature will exceed the maximum operating junction temperature when overtemperature protection is active. Continuous operation above the specified maximum operating junction temperature may impair device reliability.

# TYPICAL PERFORMANCE CHARACTERISTICS

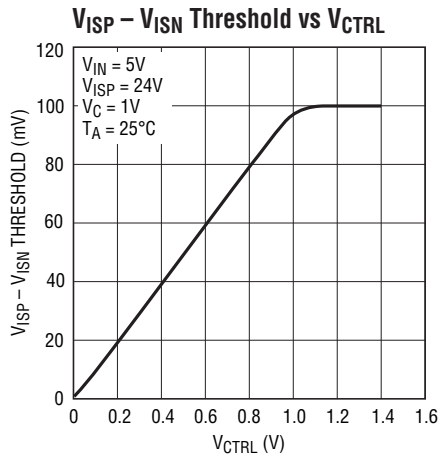

3518 G01

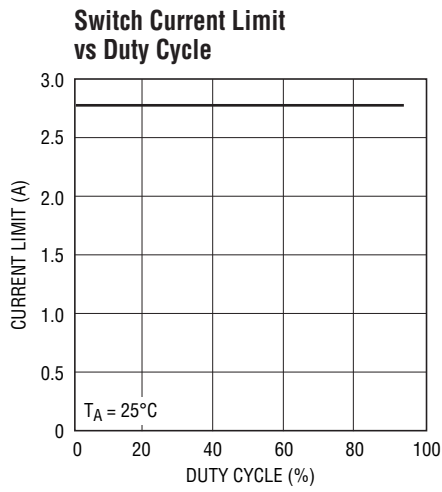

3518 G02

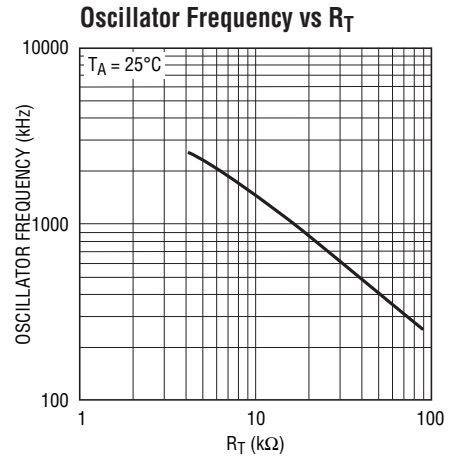

3518 G03

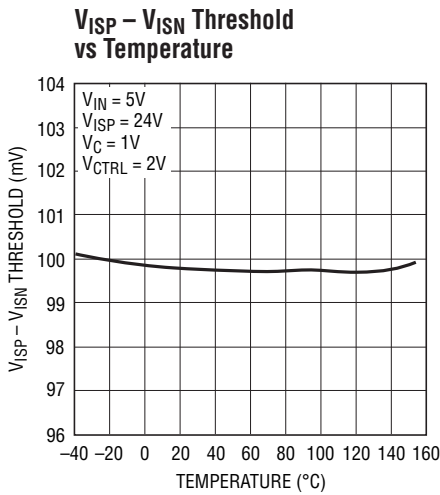

3518 G04

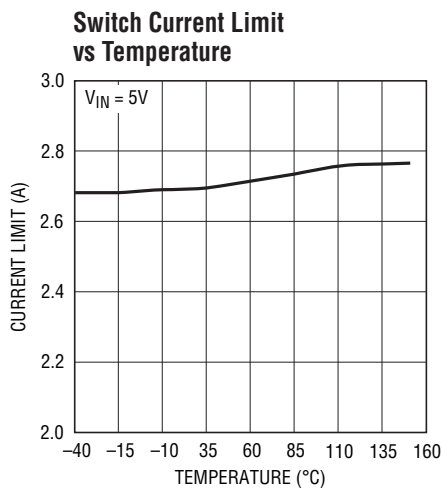

3518 G05

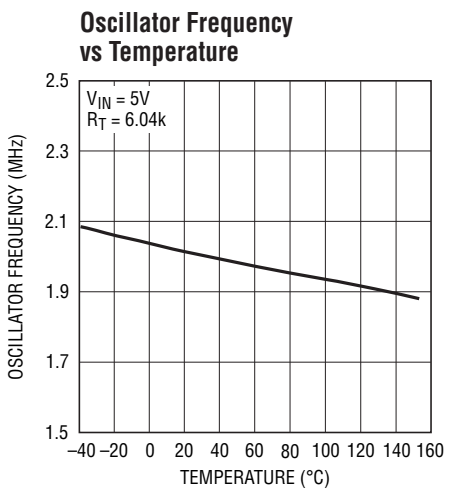

3518 G06

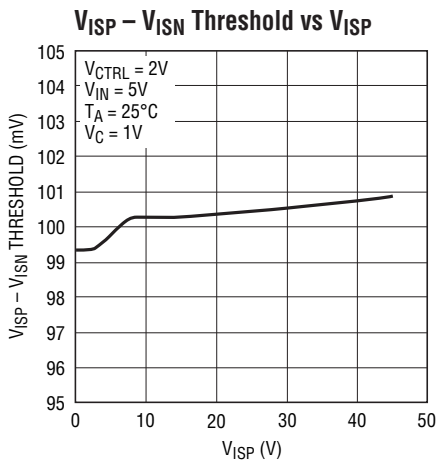

3518 G07

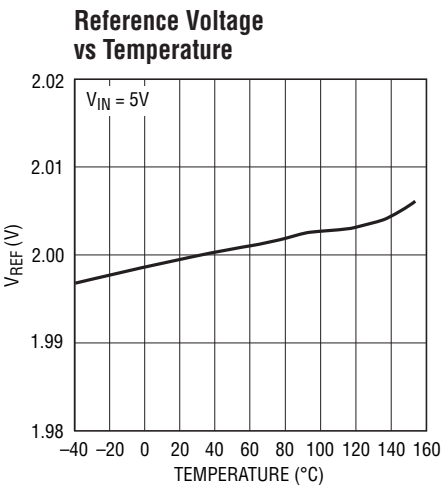

3518 G08

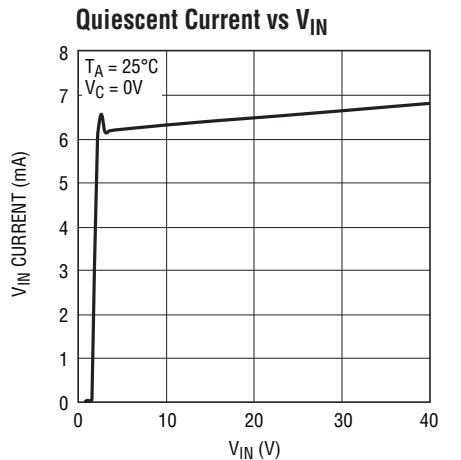

3518 G09

## TYPICAL PERFORMANCE CHARACTERISTICS

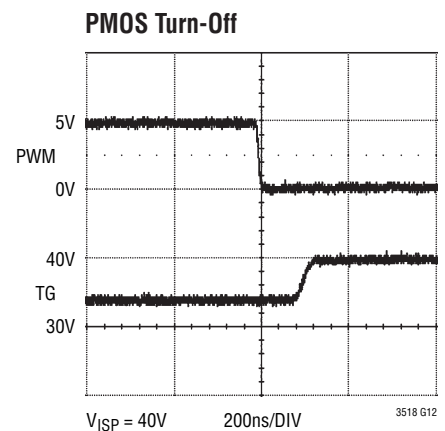
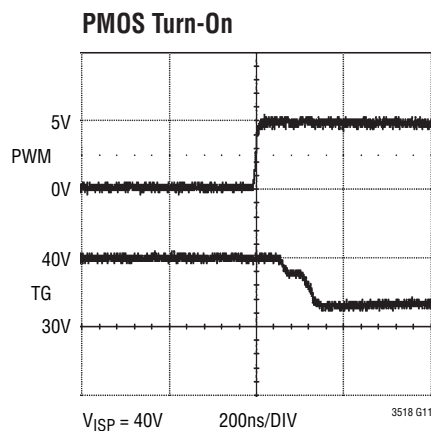
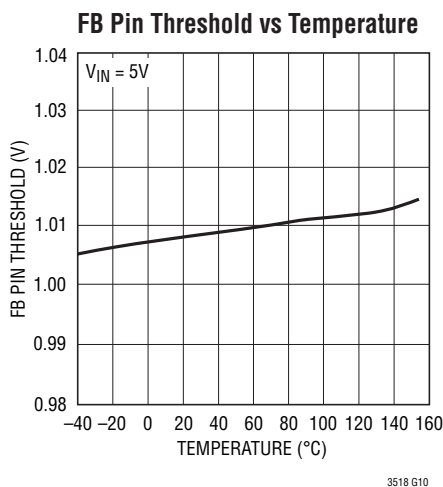

## PIN FUNCTIONS

**SW:** Switch Pin. Minimize trace at this pin to reduce EMI.

**$V_{IN}$ :** Input Supply Pin. Must be locally bypassed.

**$\overline{SHDN}$ :** Shutdown Pin. Tie to 1.5V or higher to enable device or 0.4V or less to disable device.

**$V_{REF}$ :** Reference Output Pin. This pin can supply up to 100 $\mu$ A.

**$R_T$ :** Switching Frequency Adjustment Pin. Set switching frequency using a resistor to GND (see Typical Performance Characteristics for values). For SYNC function, choose the resistor to program a frequency 20% slower than the SYNC pulse frequency. Do not leave this pin open.

**SYNC:** Frequency Synchronization Pin. Tie an external clock signal here.  $R_T$  resistor should be chosen to program a switching frequency 20% slower than SYNC pulse frequency. Synchronization (power switch turn-on) occurs a fixed delay after the rising edge of SYNC. Tie the SYNC pin to ground if this feature is not used.

**SS:** Soft-Start Pin. Place a soft-start capacitor here. Leave the pin open if not in use.

**PWM:** Pulse Width Modulated Input Pin. Signal low turns off channel, disables the main switch and makes the TG pin high. Tie the PWM pin to  $\overline{SHDN}$  pin if not used. There is an equivalent 50k resistor from PWM pin to ground internally.

**CTRL:** LED Current Adjustment Pin. Sets voltage across sense resistor between ISP and ISN. Connect directly to  $V_{REF}$  for full-scale threshold of 100mV, or use signal values between GND and 1V to modulate LED current. Tie the CTRL pin to the  $V_{REF}$  pin if not used.

**$V_C$ :**  $g_m$  Error Amplifier Output Pin. Stabilize the loop with an RC network or compensating C.

**FB:** Voltage Loop Feedback Pin. Works as overvoltage protection for LED drivers. If FB is higher than 1V, the main switch is turned off.

**TGEN:** Top Gate Enable Input Pin. Tie to 1.5V or higher to enable the PMOS driver function. Tie the TGEN pin to ground if TG function is not used. There is an equivalent 40k resistor from TGEN pin to ground internally.

**ISN:** Current Sense (-) Pin. The inverting input to the current sense amplifier.

**ISP:** Current Sense (+) Pin. The noninverting input to the current sense amplifier. Also serves as positive rail for TG pin driver.

**TG:** Top Gate Driver Output. An inverted PWM signal drives series PMOS device between  $V_{ISP}$  and ( $V_{ISP} - 7V$ ). An internal 7V clamp protects the  $V_{ISP}$  PMOS gate. Leave TG unconnected if not used.

**Ground:** Exposed Pad. Solder paddle directly to ground plane.

**BLOCK DIAGRAM**

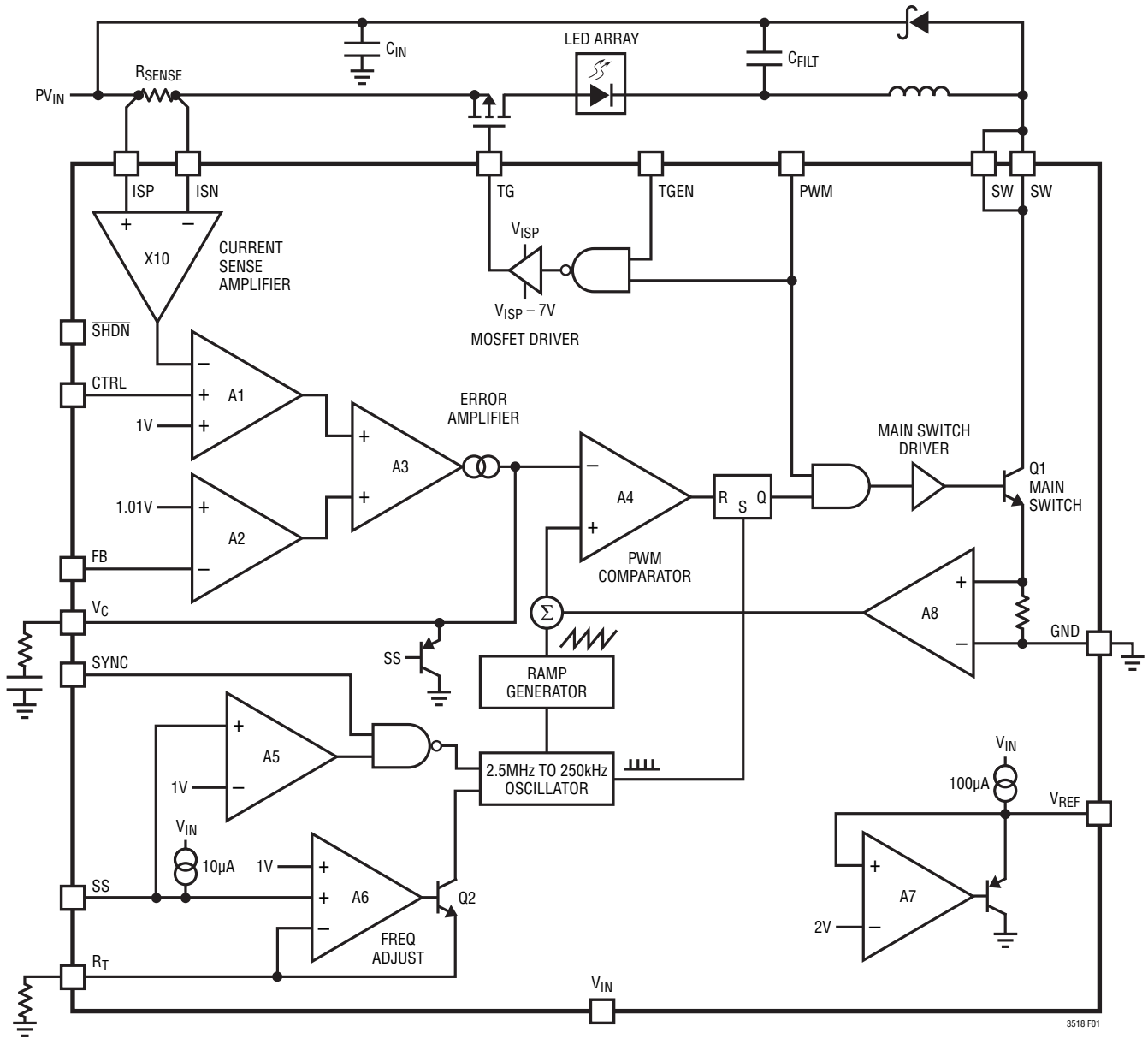

Figure 1. Buck Mode LED Driver

## OPERATION

The LT3518 is a constant frequency, current mode regulator with an internal power switch. Operation can be best understood by referring to the Block Diagram in Figure 1. At the start of each oscillator cycle, the SR latch is set, which turns on the Q1 power switch. A voltage proportional to the switch current is added to a stabilizing ramp and the resulting sum is fed into the positive terminal of the PWM comparator, A4. When this voltage exceeds the level at the negative input of A4, the SR latch is reset, turning off the power switch. The level at the negative input of A4 is set by the error amplifier A3. A3 has two inputs, one from the voltage feedback loop and the other one from the current loop. Whichever feedback input is lower takes precedence, and forces the converter into either constant-current or constant-voltage mode. The LT3518 is designed to transition cleanly between these two modes of operation. The current sense amplifier senses the voltage across  $R_{SENSE}$  and provides a pre-gain to amplifier A1. The output of A1 is simply an amplified version of the difference between the voltage across  $R_{SENSE}$  and the lower of  $V_{CTRL}/10$  or 100mV. In this manner, the error amplifier sets the correct peak switch current level to regulate the current through  $R_{SENSE}$ . If the error amplifier's output increases,

more current is delivered to the output; if it decreases, less current is delivered. The current regulated in  $R_{SENSE}$  can be adjusted by changing the input voltage  $V_{CTRL}$ . The current sense amplifier provides rail-to-rail current sense operation. The FB voltage loop is implemented by the amplifier A2. When the voltage loop dominates, the error amplifier and the amplifier A2 regulate the FB pin to 1.01V (constant-voltage mode).

Dimming of the LED array is accomplished by pulsing the LED current using the PWM pin. When the PWM pin is low, switching is disabled and the error amplifier is turned off so that it does not drive the  $V_C$  pin. Also, all internal loads on the  $V_C$  pin are disabled so that the charge state of the  $V_C$  pin will be saved on the external compensation capacitor. This feature reduces transient recovery time. When the PWM input again transitions high, the demand current for the switch returns to the value just before PWM last transitioned low. To further reduce transient recovery time, an external PMOS is used to disconnect the LED array current loop when PWM is low, stopping  $C_{FILT}$  from discharging.



## APPLICATIONS INFORMATION

### Dimming Control

There are two methods to control the current source for dimming using the LT3518. The first method uses the PWM pin to modulate the current source between zero and full current to achieve a precisely programmed average current. To make this method of current control more accurate, the switch demand current is stored on the  $V_C$  node during the quiescent phase. This feature minimizes recovery time when the PWM signal goes high. To further improve the recovery time, a disconnect switch is used in the LED current path to prevent the output capacitor from discharging in the PWM signal low phase. The minimum PWM on or off time will depend on the choice of operating frequency through  $R_T$  input pin or SYNC pin. When using the SYNC function, the SYNC and PWM signals must have the aligned rising edges to achieve the optimized high PWM dimming ratio. For best current accuracy, the minimum PWM low or high time should be at least six switching cycles ( $3\mu\text{s}$  for  $f_{\text{SW}} = 2\text{MHz}$ ). Maximum PWM period is determined by the system and is unlikely to be longer than 12ms. The maximum PWM dimming ratio ( $\text{PWM}_{\text{RATIO}}$ ) can be calculated from the maximum PWM period ( $t_{\text{MAX}}$ ) and the minimum PWM pulse width ( $t_{\text{MIN}}$ ) as follows:

$$\text{PWM}_{\text{RATIO}} = \frac{t_{\text{MAX}}}{t_{\text{MIN}}} \quad (1)$$

Example:

$$t_{\text{MAX}} = 9\text{ms}, t_{\text{MIN}} = 3\mu\text{s} (f_{\text{SW}} = 2\text{MHz})$$

$$\text{PWM}_{\text{RATIO}} = 9\text{ms}/3\mu\text{s} = 3000:1$$

The second method of dimming control uses the CTRL pin to linearly adjust the current sense threshold during the PWM high state. When the CTRL pin voltage is less than 1V, the LED current is:

$$I_{\text{LED}} = \frac{V_{\text{CTRL}}}{10 \cdot R_{\text{SENSE}}} \quad (2)$$

When  $V_{\text{CTRL}}$  is higher than 1V, the LED current is clamped to be:

$$I_{\text{LED}} = \frac{100\text{mV}}{R_{\text{SENSE}}} \quad (3)$$

The LED current programming feature possibly increases total dimming range by a factor of ten.

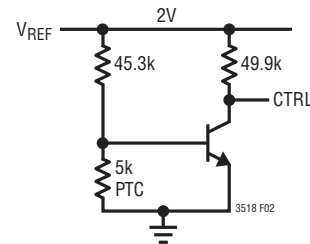

Figure 2

The CTRL pin should not be left open (tie to  $V_{\text{REF}}$  if not used). The CTRL pin can also be used in conjunction with a PTC thermistor to provide overtemperature protection for the LED load.

### Setting Output Voltage

For a boost application, the output voltage can be set by selecting the values of R1 and R2 (see Figure 3) according to the following equation:

$$V_{\text{OUT}} = \left( \frac{R1}{R2} + 1 \right) \cdot 1.01\text{V} \quad (4)$$

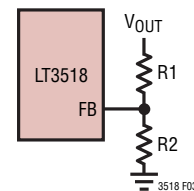

Figure 3

## APPLICATIONS INFORMATION

For a buck or a buck-boost configuration, the output voltage is typically level-shifted to a signal with respect to GND as illustrated in the Figure 4. The output can be expressed as:

$$V_{OUT} = \frac{R1}{R2} \cdot 1.01V + V_{BE(Q1)} \quad (5)$$

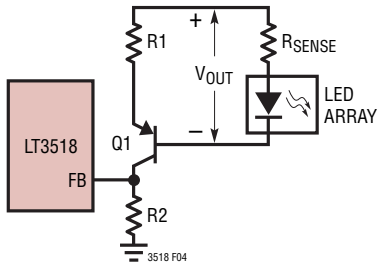

Figure 4

### Inductor Selection

The inductor used with the LT3518 should have a saturation current rating of 2A or greater. For buck mode LED drivers, the inductor value should be chosen to give a ripple current “ $\Delta I$ ” of ~30% to 40% of the LED current. In the buck mode, the inductor value can be estimated using the formula:

$$L(\mu H) = \frac{D_{BUCK} \cdot t_{SW}(\mu s) \cdot (V_{IN} - V_{LED})}{\Delta I} \quad (6)$$

$$D_{BUCK} = \frac{V_{LED}}{V_{IN}}$$

$V_{LED}$  is the voltage across the LED string,  $V_{IN}$  is the input voltage to the converter, and  $t_{SW}$  is the switching period. In the boost configuration, the inductor can be estimated using the formula:

$$L(\mu H) = \frac{D_{BOOST} \cdot t_{SW}(\mu s) \cdot V_{IN}}{\Delta I} \quad (7)$$

$$D_{BOOST} = \frac{V_{LED} - V_{IN}}{V_{LED}}$$

Table 1 provides some recommended inductor vendors.

Table 1. Inductor Manufacturers

VENDOR	PHONE	WEB
Sumida	(408) 321-9660	www.sumida.com
Toko	(408) 432-8281	www.toko.com
Cooper	(561) 998-4100	www.cooperet.com
Vishay	(402) 563-6866	www.vishay.com

### Input Capacitor Selection

For proper operation, it is necessary to place a bypass capacitor to GND close to the  $V_{IN}$  pin of the LT3518. A 1 $\mu$ F or greater capacitor with low ESR should be used. A ceramic capacitor is usually the best choice.

In the buck mode configuration, the capacitor at the input to the power converter has large pulsed currents due to the current returned through the Schottky diode when the switch is off. For best reliability, this capacitor should have low ESR and ESL and have an adequate ripple current rating. The RMS input current is:

$$I_{IN(RMS)} = I_{LED} \cdot \sqrt{(1-D) \cdot D} \quad (8)$$

where D is the switch duty cycle. A 2.2 $\mu$ F ceramic type capacitor is usually sufficient.

### Output Capacitor Selection

The selection of output capacitor depends on the load and converter configuration, i.e., step-up or step-down. For LED applications, the equivalent resistance of the LED is typically low, and the output filter capacitor should be sized to attenuate the current ripple.

To achieve the same LED ripple current, the required filter capacitor value is larger in the boost and buck-boost mode applications than that in the buck mode applications. For LED buck mode applications, a 1 $\mu$ F ceramic capacitor is usually sufficient. For the LED boost and buck-boost mode applications, a 2.2 $\mu$ F ceramic capacitor is usually sufficient. Very high performance PWM dimming applications may require a larger capacitor value to support the LED voltage during PWM transitions.

## APPLICATIONS INFORMATION

Use only ceramic capacitors with X7R, X5R or better dielectric as they are best for temperature and DC bias stability of the capacitor value. All ceramic capacitors exhibit loss of capacitance value with increasing DC voltage bias, so it may be necessary to choose a higher value capacitor to get the required capacitance at the operation voltage. Always check that the voltage rating of the capacitor is sufficient. Table 2 shows some recommended capacitor vendors.

**Table 2. Ceramic Capacitor Manufacturers**

VENDOR	PHONE	WEB
Taiyo Yuden	(408) 573-4150	www.t-yuden.com
AVX	(843) 448-9411	www.avxcorp.com
Murata	(770) 436-1300	www.murata.com
TDK	(847) 803-6100	www.tdk.com

### Loop Compensation

The LT3518 uses an internal transconductance error amplifier whose  $V_C$  output compensates the control loop. The external inductor, output capacitor, and the compensation resistor and capacitor determine the loop stability. The inductor and output capacitor are chosen based on performance, size and cost. The compensation resistor and capacitor at  $V_C$  are selected to optimize control loop stability. For typical LED applications, a 10nF compensation capacitor at  $V_C$  is adequate, and a series resistor is not required. A compensation resistor may be used to increase the slew rate on the  $V_C$  pin to maintain tighter regulation of LED current during fast transients on  $V_{IN}$  or CTRL.

### Diode Selection

The Schottky diode conducts current during the interval when the switch is turned off. Select a diode rated for the maximum SW voltage. If using the PWM feature for dimming, it is important to consider diode leakage, which increases with the temperature, from the output during the PWM low interval. Therefore, choose the Schottky diode with sufficiently low leakage current. Table 3 has some recommended component vendors.

**Table 3. Schottky Diodes**

PART NUMBER	$V_R$ (V)	$I_{AVE}$ (A)
<b>On Semiconductor</b>		
MBRS260T3	60	2
<b>Diodes Inc.</b>		
DFLS140L	40	1
<b>Zetex</b>		
ZLLS2000TA	40	2.2
<b>International Rectifier</b>		
10MQ060N	60	1.5

### Board Layout

The high speed operation of the LT3518 demands careful attention to board layout and component placement. The Exposed Pad of the package is the only GND terminal of the IC and is also important for thermal management of the IC. It is crucial to achieve a good electrical and thermal contact between the Exposed Pad and the ground plane of the board. To reduce electromagnetic interference (EMI), it is important to minimize the area of the SW node. Use a GND plane under SW and minimize the length of traces in the high frequency switching path between SW and GND through the diode and the capacitors. Since there is a small DC input bias current to the ISN and ISP inputs, resistance in series with these inputs should be minimized and matched, otherwise there will be an offset. Finally, the bypass capacitor on the  $V_{IN}$  supply to the LT3518 should be placed as close as possible to the  $V_{IN}$  terminal of the device.

### Soft-Start

For many applications, it is necessary to minimize the inrush current at start-up. The built-in soft-start circuit significantly reduces the start-up current spike and output voltage overshoot. A typical value for the soft-start capacitor is 0.1 $\mu$ F.

## APPLICATIONS INFORMATION

### Switching Frequency

There are two methods to set the switching frequency of LT3518. Both methods require a resistor connected at  $R_T$  pin. Do not leave the  $R_T$  pin open. Also, do not load this pin with a capacitor. A resistor must always be connected for proper operation. One way to set the frequency is simply connecting an external resistor between the  $R_T$  pin and GND. See Table 4 below or see the Oscillator Frequency vs  $R_T$  graph in the Typical Performance Characteristics for resistor values and corresponding switching frequencies.

**Table 4. Switching Frequency vs  $R_T$**

Switching Frequency (kHz)	$R_T$ ( $k\Omega$ )
250	90.9
500	39.2
1000	16.9
1500	9.53
2000	6.04
2500	4.02

The other way is to make the LT3518 synchronize with an external clock via SYNC pin. For proper operation, a resistor should be connected at the  $R_T$  pin and be able to generate a switching frequency 20% lower than the external clock when external clock is absent.

In general, a lower switching frequency should be used where either very high or very low switching duty cycle operation is required, or high efficiency is desired. Selection of a higher switching frequency will allow use of smaller value external components and yield a smaller solution size and profile.

### Thermal Considerations

The LT3518 is rated to a maximum input voltage of 30V for continuous operation, and 40V for nonrepetitive one second transients. Careful attention must be paid to the internal power dissipation of the LT3518 at higher input voltages to ensure that the maximum junction temperature is not exceeded. This junction limit is especially important when operating at high ambient temperatures. The Exposed Pad on the bottom of the package must be soldered to a ground plane. This ground should then be connected to an internal copper ground plane with thermal vias placed directly under the package to spread out the heat dissipated by the LT3518.

# TYPICAL APPLICATIONS

## Buck Mode 1.5A LED Driver

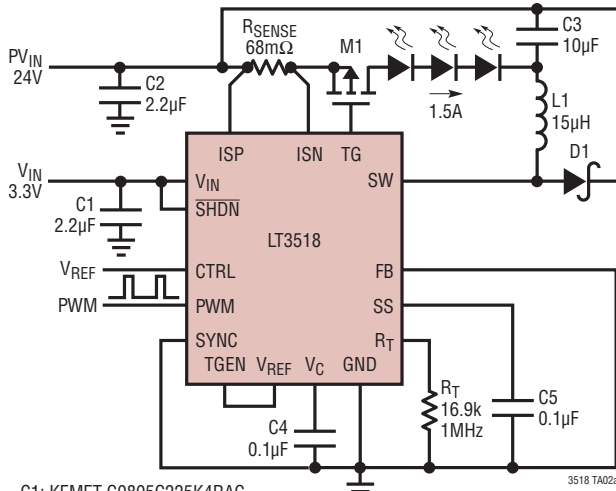

- C1: KEMET C0805C225K4RAC
- C2: MURATA GRM31MR71E225KA93
- C3: MURATA GRM32DR71E106KA12B
- C4, C5: MURATA GRM21BR71H104KA01B
- D1: ZETEX ZLLS2000TA
- L1: TOKO B992AS-150M
- LEDS: LUXEON K2 (WHITE)
- M1: ZETEX ZXMP6A13GTA

1000:1 PWM Dimming at 120Hz

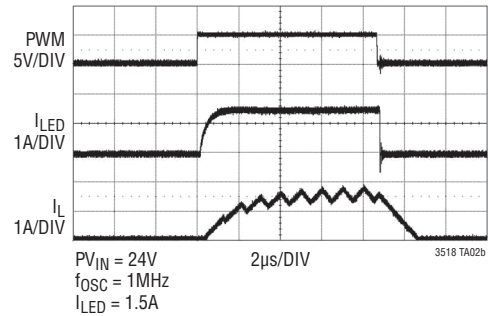

## 500mA, 5V to 12V Boost Converter with Accurate Input Current Limit

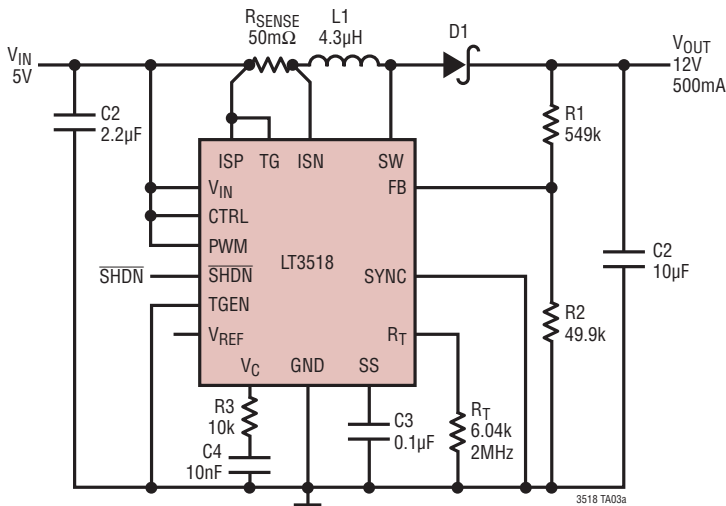

- C1: KEMET C0805C225K4RAC
- C2: KEMET C1206C106K4RAC
- C3: MURATA GRM21BR71H104KA01B
- C4: MURATA GCM033R71A103KA03
- D1: ZETEX ZLLS2000TA
- L1: TOKO B992AS-4R3N

Efficiency

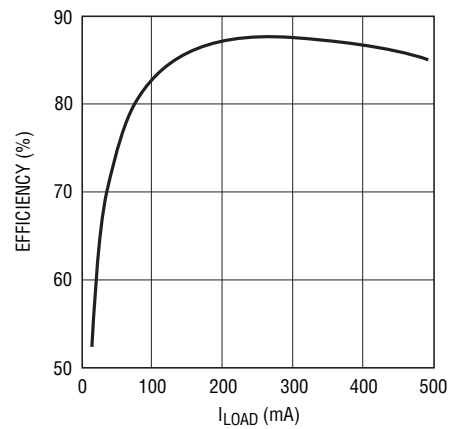

## TYPICAL APPLICATIONS

### Buck-Boost Mode LED Driver

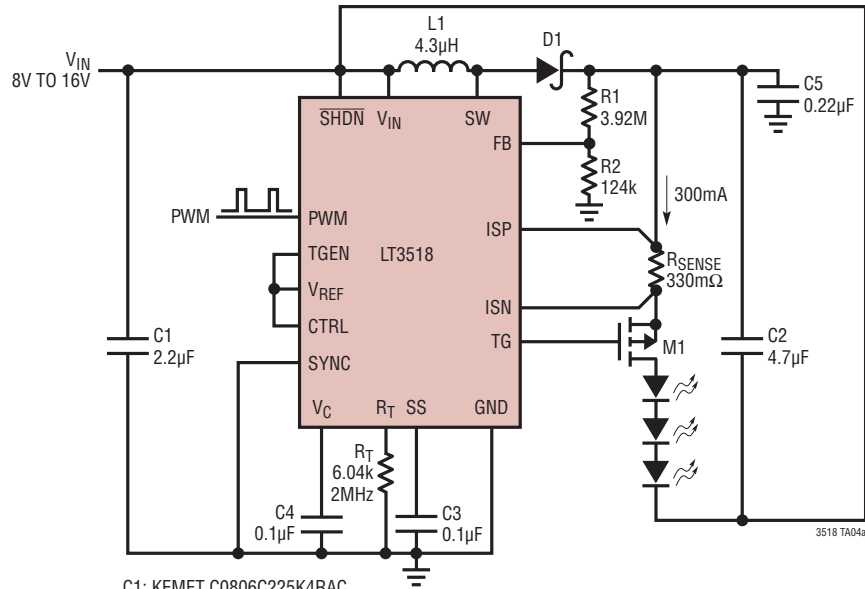

- C1: KEMET C0806C225K4RAC
- C2: KEMET C1206C475K3RAC
- C3, C4: MURATA GRM21BR71H104KA01B
- C5: MURATA GRM21BR71H224KA01B
- D1: ZETEX ZLLS2000TA
- L1: TOKO B992AS-4R3N
- LEDS: LUXEON I (WHITE)
- M1: ZETEX ZXMP6A13GTA

### 3000:1 PWM Dimming at 120Hz



### Efficiency

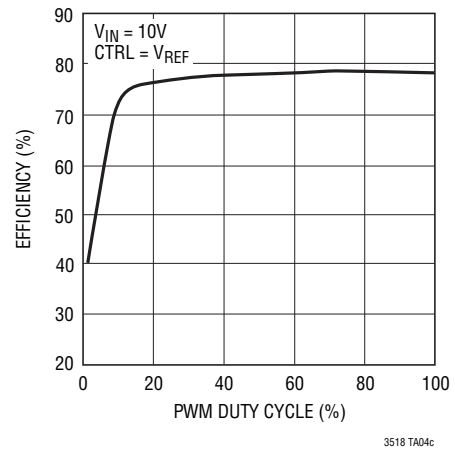

# TYPICAL APPLICATIONS

## Buck Mode 1A LED Driver with Open LED Protection and Sync Input

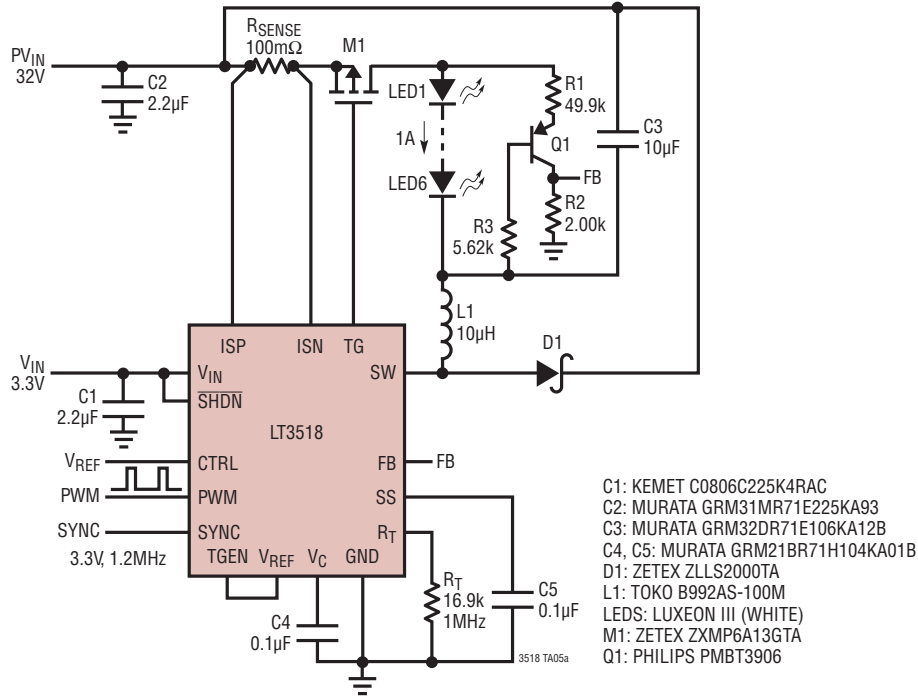

1000:1 PWM Dimming at 120Hz

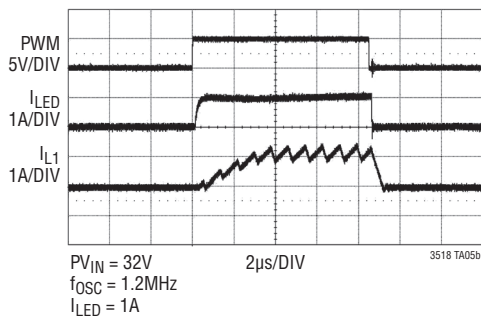

Efficiency

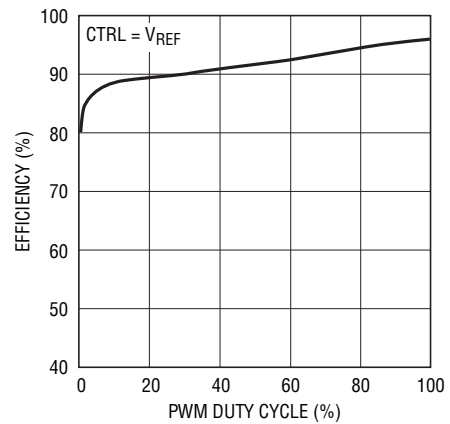

3518 TA05c

## TYPICAL APPLICATIONS

### Boost 300mA LED Driver with LED Open Protection

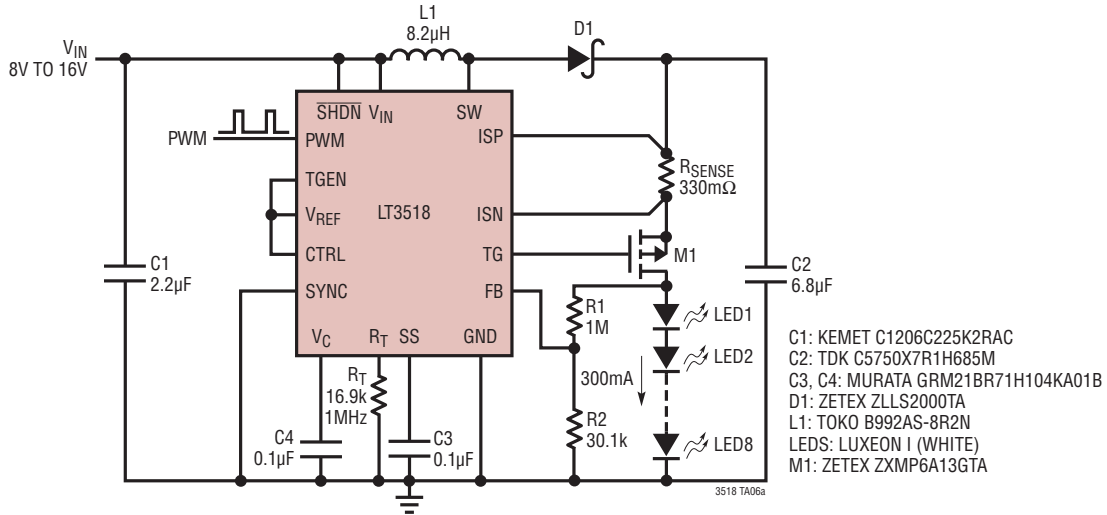

3000:1 PWM Dimming at 100Hz

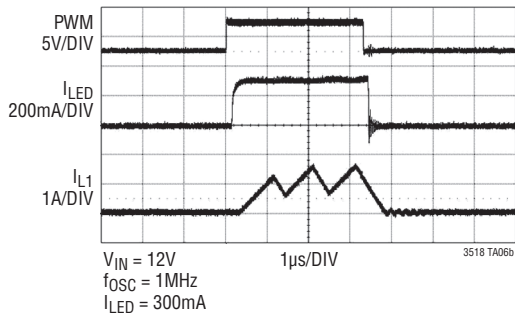

Efficiency

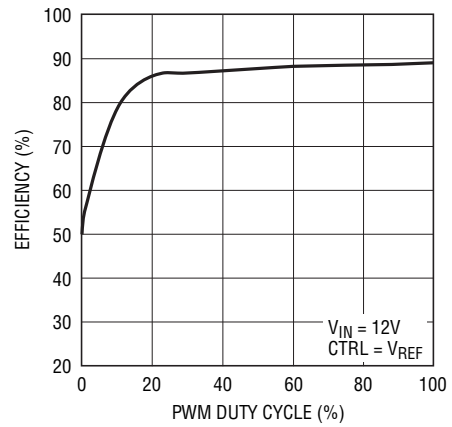

3518 TA06c



# PACKAGE DESCRIPTION

**UF Package**  
**16-Lead Plastic QFN (4mm × 4mm)**  
 (Reference LTC DWG # 05-08-1692)

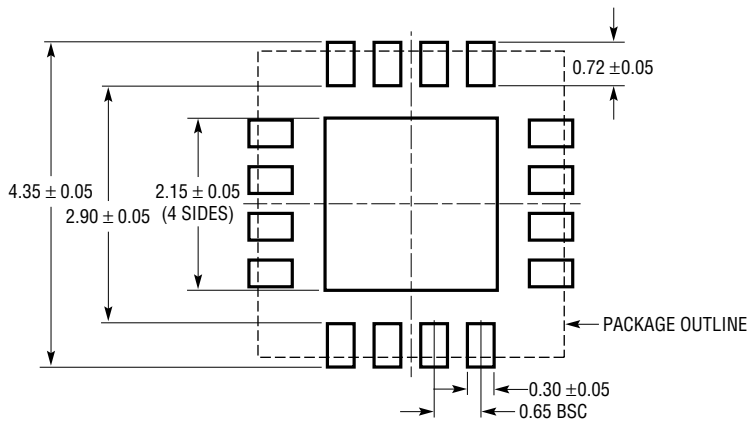

RECOMMENDED SOLDER PAD PITCH AND DIMENSIONS

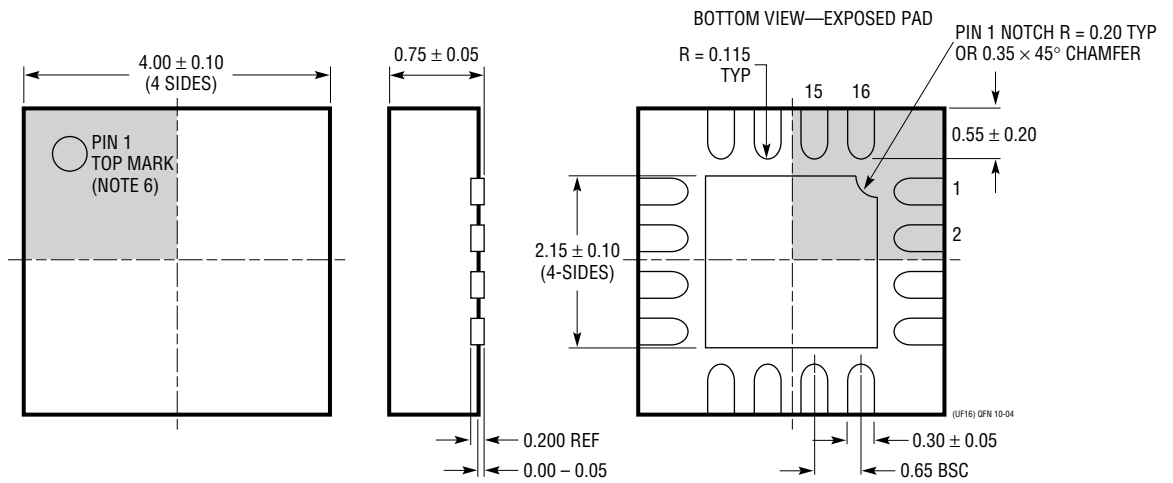

- NOTE:
1. DRAWING CONFORMS TO JEDEC PACKAGE OUTLINE MO-220 VARIATION (WGCC)
  2. DRAWING NOT TO SCALE
  3. ALL DIMENSIONS ARE IN MILLIMETERS
  4. DIMENSIONS OF EXPOSED PAD ON BOTTOM OF PACKAGE DO NOT INCLUDE MOLD FLASH. MOLD FLASH, IF PRESENT, SHALL NOT EXCEED 0.15mm ON ANY SIDE
  5. EXPOSED PAD SHALL BE SOLDER PLATED
  6. SHADED AREA IS ONLY A REFERENCE FOR PIN 1 LOCATION ON THE TOP AND BOTTOM OF PACKAGE

**PACKAGE DESCRIPTION**

**FE Package**  
**16-Lead Plastic TSSOP (4.4mm)**  
 (Reference LTC DWG # 05-08-1663 Rev H)  
**Exposed Pad Variation BA**

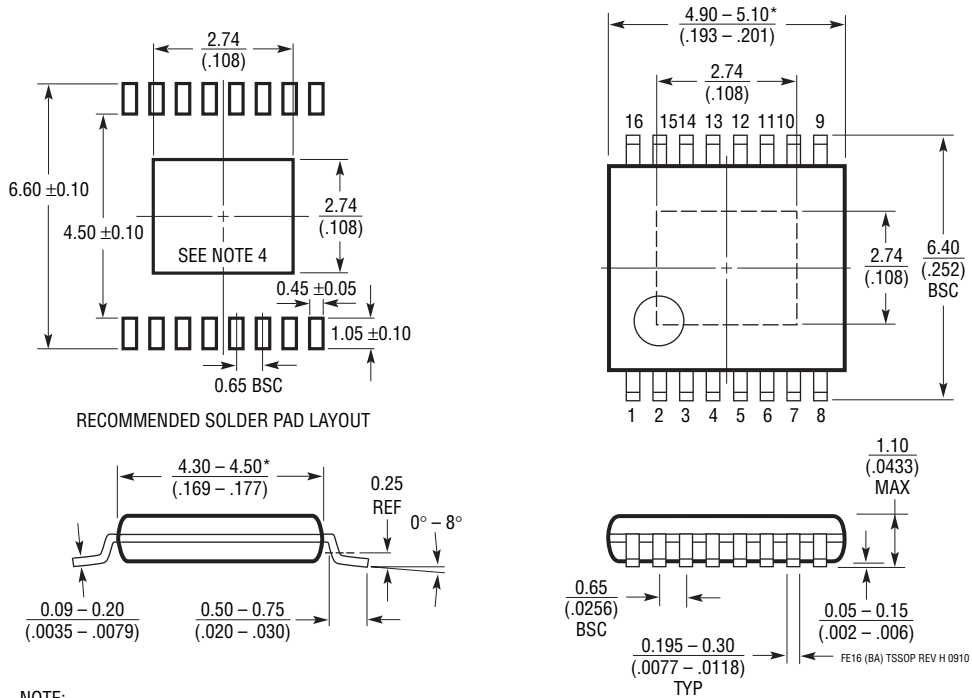

- NOTE:
- 1. CONTROLLING DIMENSION: MILLIMETERS
  - 2. DIMENSIONS ARE IN  $\frac{\text{MILLIMETERS}}{\text{(INCHES)}}$
  - 3. DRAWING NOT TO SCALE
  - 4. RECOMMENDED MINIMUM PCB METAL SIZE FOR EXPOSED PAD ATTACHMENT
- \*DIMENSIONS DO NOT INCLUDE MOLD FLASH. MOLD FLASH SHALL NOT EXCEED 0.150mm (.006") PER SIDE

**REVISION HISTORY** (Revision history begins at Rev D)

REV	DATE	DESCRIPTION	PAGE NUMBER
D	01/11	Revised Electrical Characteristics	3

## TYPICAL APPLICATION

### 5.5V SEPIC Converter with Short-Circuit Protection

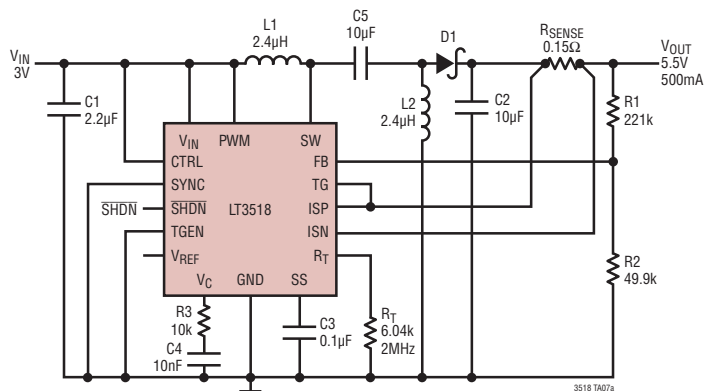

C1: KEMET C0805C225K4RAC  
 C2, C5: KEMET C1206C106K4RAC  
 C3: MURATA GRM21BR71H104KA01B  
 C4: MURATA GCM033R71A103KA03  
 D1: ZETEX ZLLS2000TA  
 L1, L2: TOKO 962BS-2R4M

### Efficiency

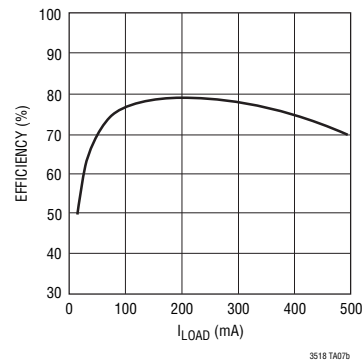

## RELATED PARTS

PART NUMBER	DESCRIPTION	COMMENTS
LT1618	Constant Current, 1.4MHz, 1.5A Boost Converter	V <sub>IN</sub> : 5V to 18V, V <sub>OUT(MAX)</sub> = 36V, Dimming = Analog/PWM, I <sub>SD</sub> < 1µA, MSOP10 Package
LT3003	3-Channel LED Ballaster with PWM Dimming	V <sub>IN</sub> : 3V to 48V, Dimming = 3000:1 True Color PWM, I <sub>SD</sub> < 5µA, MSOP10 Package
LT3474	36V, 1A (I <sub>LED</sub> ), 2MHz, Step-Down LED Driver	V <sub>IN</sub> : 4V to 36V, V <sub>OUT(MAX)</sub> = 13.5V, Dimming = 400:1 True Color PWM, I <sub>SD</sub> < 1µA, TSSOP16E Package
LT3475	Dual 1.5A (I <sub>LED</sub> ), 36V 2MHz Step-Down LED Driver	V <sub>IN</sub> : 4V to 36V, V <sub>OUT(MAX)</sub> = 13.5V, Dimming = 3000:1 True Color PWM, I <sub>SD</sub> < 1µA, TSSOP20E Package
LT3476	Quad Output 1.5A, 36V, 2MHz High Current LED Driver with 1,000:1 Dimming	V <sub>IN</sub> : 2.8V to 16V, V <sub>OUT(MAX)</sub> = 36V, Dimming = 1000:1 True Color PWM, I <sub>SD</sub> < 10µA, 5mm × 7mm QFN Package
LT3477	3A, 42V, 3MHz Boost, Buck-Boost, Buck LED Driver	V <sub>IN</sub> : 2.5V to 25V, V <sub>OUT(MAX)</sub> = 40V, Dimming = Analog/PWM, I <sub>SD</sub> < 1µA, QFN, TSSOP20E Packages
LT3478/LT3478-1	4.5A, 42V, 2.5MHz High Current LED Driver with 3,000:1 Dimming	V <sub>IN</sub> : 2.8V to 36V, V <sub>OUT(MAX)</sub> = 42V, Dimming = 3000:1 True Color PWM, I <sub>SD</sub> < 3µA, TSSOP16E Packages
LT3479	3A, Full Featured DC/DC Converter with Soft-Start and Inrush Current Protection	V <sub>IN</sub> : 2.5V to 24V, V <sub>OUT(MAX)</sub> = 40V, I <sub>Q</sub> = 6.5mA, I <sub>SD</sub> < 1µA, DFN and TSSOP Packages
LT3486	Dual 1.3A, 2MHz High Current LED Driver	V <sub>IN</sub> : 2.5V to 24V, V <sub>OUT(MAX)</sub> = 36V, Dimming = 1000:1 True Color PWM, I <sub>SD</sub> < 1µA, 5mm × 3mm DFN, TSSOP16E
LT3496	Triple Output LED Driver	V <sub>IN</sub> : 3V to 40V, V <sub>OUT(MAX)</sub> = 45V, Dimming = 3000:1 True Color PWM, I <sub>SD</sub> < 10µA, 4mm × 5mm QFN Package
LT3517	Full-Featured LED Driver with 1.5A Switch Current	V <sub>IN</sub> : 3V to 40V, V <sub>OUT(MAX)</sub> = 45V, Dimming = 5000:1 True Color PWM, I <sub>SD</sub> < 1µA, 4mm × 4mm QFN and TSSOP Packages
LT3590	48V Buck Mode 50mA LED Driver	V <sub>IN</sub> : 4.5V to 55V, Drives Up to 10 LEDs, 200:1 Dimming, I <sub>SO</sub> = 15mA, 2mm × 2mm DFN SC70
LT3595	16 Channel Buck LED Driver Mode	V <sub>IN</sub> : 4.5V to 45V, Drives Up to 160 LEDs, 5000:1 Dimming, 5mm × 9mm QFN
LTC®3783	High Current LED Controller	V <sub>IN</sub> : 3V to 36V, V <sub>OUT(MAX)</sub> = Ext FET, Dimming = 3000:1 True Color PWM, I <sub>SD</sub> < 20µA, 5mm × 4mm QFN10, TSSOP16E Packages