



Chunghwa Picture Tubes, Ltd. Product Specification

To : RB_
Date : 080612

TFT LCD
CLAA102NA01CW

ACCEPTED BY : (V0.4)

APPROVED BY	CHECKED BY	PREPARED BY
張聖暉	李家銘	羅宇城

Prepared by :
Product Planning Management Division
Small & Medium TFT Product Business Unit
CHUNGHWA PICTURE TUBES, LTD.

1127 Hopin Rd., Padeh, Taoyuan, Taiwan 334, R.O.C.
TEL: +886-3-3675151 FAX: +886-3-377-3858

Doc.No:	SPEC_CLAA102NA01CW_V0.4_RB_080612	Issue Date:	2008/03/17
---------	-----------------------------------	-------------	------------

REVISION STATUS

Revision Notice	Description	Page	Rev. Date
Ver. 0.0	First revision (Tentative)		2007.04.09
0.1	Modify the sign sequence	8	2007.05.28
	Modify Interface Connection (CN1)	10	
	Modify the Rear side of Mechanical Dimension	15	
	Modify Viewing angle	16	
0.2	Revise the specification of power consumption and viewing angle	4	2007.09.03
	Add the value of I_{CC} .	8	
	Revise the table of interface connection	10	
	Add the color coordinate of R,G,B	16	
0.3	Modify Module Mechanical Dimension	15	2008.01.28
0.4	Revise the Reliability Test	18	2008.03.17

CONTENTS

1. OVERVIEW	4
2. ABSOLUTE MAXIMUM RATINGS	5
3. ELECTRICAL CHARACTERISTICS	7
3.1 TFT LCD	7
3.2 TFT-LCD Current Consumption	8
3.3 Power · Signal sequence	8
3.4 Backlight.....	9
4. INTERFACE CONNECTION	10
4.1 CN1.....	10
5. INPUT SIGNAL(DE ONLY MODE)	11
5.1 Timing Specification	11
5.2 Timing sequence(Timing chart).....	11
6. BLOCK DIAGRAM	14
7. MECHANICAL DIMENSION	15
7.1 Front Side	[Unit : mm]... 15
7.2 Rear Side	15
8. OPTICAL CHARACTERISTICS	16
9. RELIABILITY TEST	18
9-1. Temperature and humidity	18
9.2. Shock and Vibration	18
9.3. ESD Test.....	18
9.4 Judgment standard.....	18

1. OVERVIEW

CLAA102NA01CW is 10.2" color TFT-LCD (Thin Film Transistor Liquid Crystal Display) module composed of LCD panel, driver ICs ,control circuit and backlight. By applying 1024×600 images are displayed on the 10.2" diagonal screen. Display 262K colors by 6 Bit R.G.B signal input.

General specification are summarized in the following table:

ITEM	SPECIFICATION
Display Area (mm)	222.72(H) x 130.5(V) (10.2-inch diagonal)
Number of Pixels	1024(H) × 3(RGB) × 600(V)
Pixel Pitch (mm)	0.2175 (H) × 0.2175 (V)
Color Pixel Arrangement	RGB vertical stripe
Display Mode	Normally white, TN
Number of Colors	262,144
Optimum Viewing Angle	6 o'clock
Brightness (cd/m ²)	400nit(typ)
Response Time (ms)	25ms (typ)
Viewing Angle	140 degree (Horizontal.)
	110 degree (Vertical)
Power Consumption (with BLU)	6.6W(typ)
Interface connection	LVDS
Module Size (mm) (w/o PWB)	235(W) × 145.8(H) × 5.9(D)
Module Size (mm) (with PET)	235(W) × 145.8(H) × 7.86(D)
Module Weight (g)	385g (Max)
Backlight Unit	CCFL
Surface Treatment	Anti-Glare

2. ABSOLUTE MAXIMUM RATINGS

The following are maximum values which, if exceeded, may cause faulty operation or damage to the unit.

Item	Symbol	Min.	Max.	Unit	Note
Power Supply Voltage	Vcc	-0.3	4.0	V	
Singal Input Voltage	RxIN0+ ~ RxIN2+ RxIN0- ~ RxIN2- Rx CLK IN +/-	-0.3	Vcc + 0.3	V	
Lamp Voltage	VL	670	850	Vrms	
Lamp Current	IL	5	7	mArms	【Note 4】
Lamp Frequency	FL	40	80	KHz	【Note 4】
Static Electricity	VESDc	-200	200	V	【Note2】
	VESDm	-15K	15K	V	
ICC Rush Current	IRUSH	-	TBD	A	【Note 3】
Operation Temperature	T _{op}	-30	85	°C	【Note 1】
Storage Temperature	T _{stg}	-40	95	°C	【Note 1】
Discharge Time Lag	TD	-	1	sec	【Note 6】

【Note】

【Note1】

If users use the product out off the environment operation range (temperature and humidity) ,it will concern for visual quality.

【Note2】

Test Condition: IEC 61000-4-2 ,

VESDc : Contact discharge to input connector

VESDm : Discontact discharge to module

【Note3】

The input pulse-current measurement system as below :

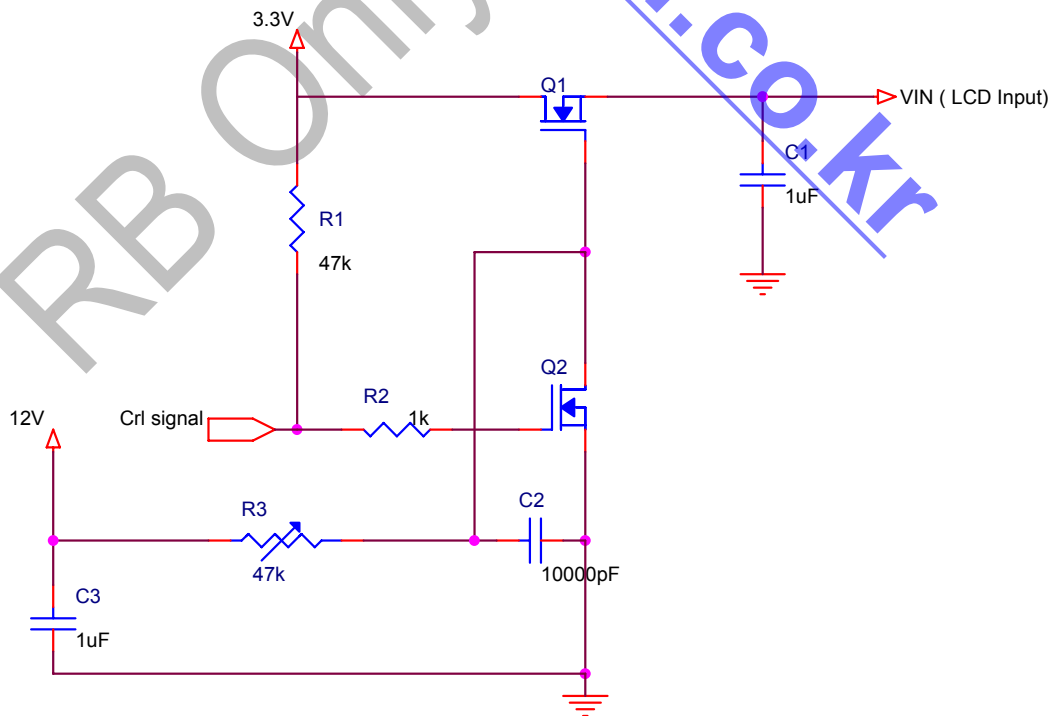

Control signal: High(+3.3V)→Low(GND)

Supply Voltage of rising time should be from R3 and C2 tune to 550 us.

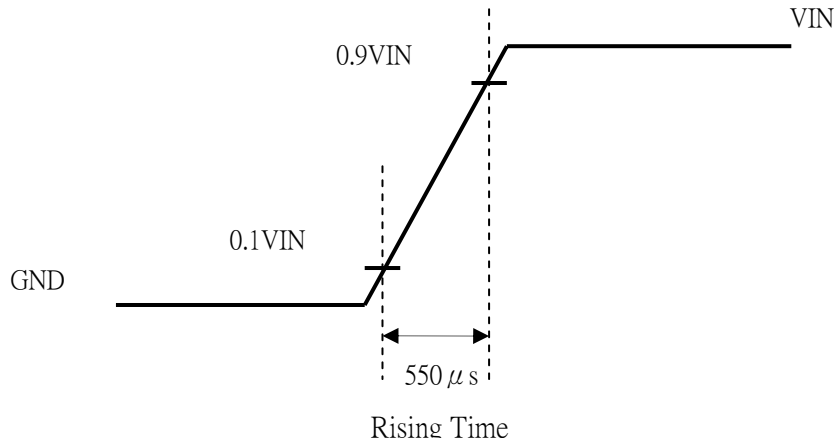

【Note 4】

Table of specifications are definition of single lamp .

【Note 5】

The frequency is operated in the range, will not influence the life of lamp and display characteristic.

Note 6】

The time needed to start discharge when the over Starting Lamp Voltage is continuously applied to both ends of the lamp. Before testing, the lamp is left in the dark room (ambient temperature : $25\pm 2^{\circ}\text{C}$, ambient illuminance : less than 0.1lux) for 24Hr after lighted for 1 minute at rated lamp current. The testing shall be conducted in the dark room. And the sealing side shall be connected to high voltage side. (ambient temperature : $25\pm 2^{\circ}\text{C}$, ambient illuminance : less than 0.1lux). The minimum safety time for the inverter need over the maximum time for the start discharge .

3. ELECTRICAL CHARACTERISTICS

3.1 TFT LCD

Ta=25°C

Item	Symbol	Min.	Typ	Max.	Unit	Note	
Power Supply Voltage For LCD	V_{CC}	3.0	3.3	3.6	V	*1)	
Logic Input Voltage (LVDS:IN+,IN-)	Input Voltage	V_{IN}	0	-	V_{CC}	V	*2)
	Common Mode Voltage	VCM	1.08	1.2	1.32	V	*2)
	Differential Input Voltage	VID	250	350	450	mV	*2)
	Threshold Voltage(high)	VTH	-	-	100	mV	*2) VCM=+1.2V
	Threshold Voltage(low)	VTL	-100	-	-	mV	*2)

Remarks :

*1) VCC –dip codition:

- 1) When $2.7\text{ V} \leq V_{CC} < 3.0\text{ V}$, $t_d \leq 10\text{ ms}$.
- 2) $V_{CC} > 3.0\text{ V}$, VCC-dip condition should be same as VCC-turn-on condition.

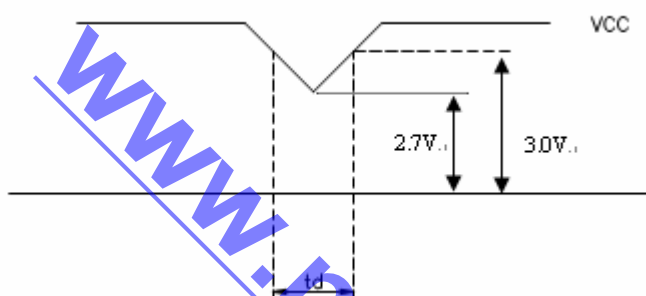

*2) LVDS signal

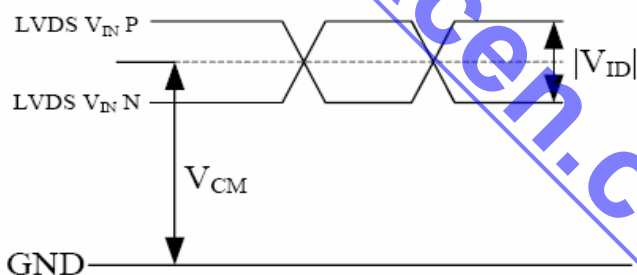

$$|VID| = |V_{TH} - V_{TL}|$$

$$V_{CM} = (V_{TH} + V_{TL})/2$$

3.2 TFT-LCD Current Consumption

Item	Symbol	Min	Type	Max	Unit	Notes
LCD power current	ICC	--	250	350	mA	*1)

Remarks:

- *1) Typical: Under 64 gray pattern @ Vcc = 3.3 V.
- Maximum: Under black pattern @ Vcc = 3.0 V



(a) 64 Gray Pattern

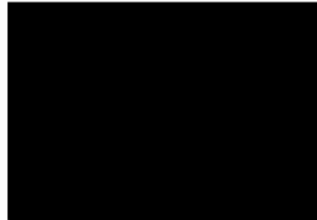

(b) Black Pattern

3.3 Power & Signal sequence

- $t1 \leq 10ms$
- $0 < t2 \leq 50ms$
- $0 < t3 \leq 50ms$
- $0 < t4 \leq 10ms$
- $1 \text{ sec} \geq t5$
- $200ms \leq t6$
- $200ms \leq t7$

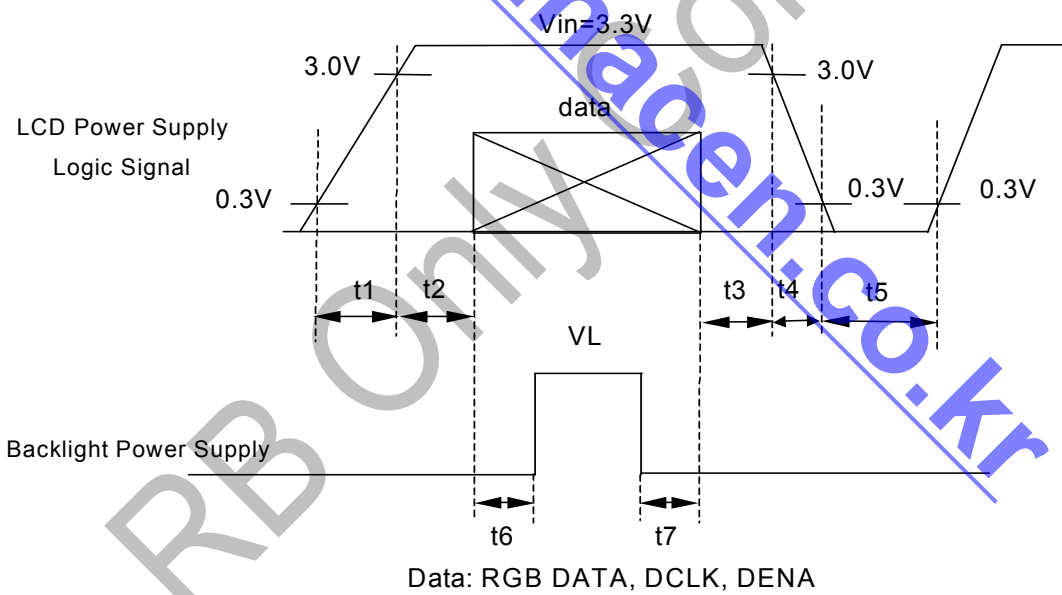

3.4 Backlight

Ta=25°C

ITEM	SYMBOL	MIN	TYP	MAX	UNIT	NOTE
Lamp current	IL	5.8	6.0	6.2	mArms	
Lamp voltage	VL	765	850	935	Vrms	*1) ; IL=8.0mA
Inverter Frequency	FI	-	57	-	kHz	*1). *2)
Start Lamp Voltage	VS	-	1050	1450	Vrms	Ta=25°C *1).3)
		-	-	2200	Vrms	Ta=0°C *1).3)
Lamp life time	IT	30,000	40,000		hr	*1).4), IL@6.0mA
Turn on and off life		100,000			times	*1).5), IL@6.0mA Continuous Operation Time Cycle 20 S.

If the driving waveform of lamp is asymmetric, the distribution of mercury inside the lamp tube will become unequally or will deplete the Ar gas in it. Then it may cause the abnormal phenomenon of lighting-up. Therefore, designers have to try their best to for fill the conditions under the inverter designing-stage as below:

- The degrees of unbalance : < 10 %
- The ratio of wave height : < $\sqrt{2} \pm 10$ %

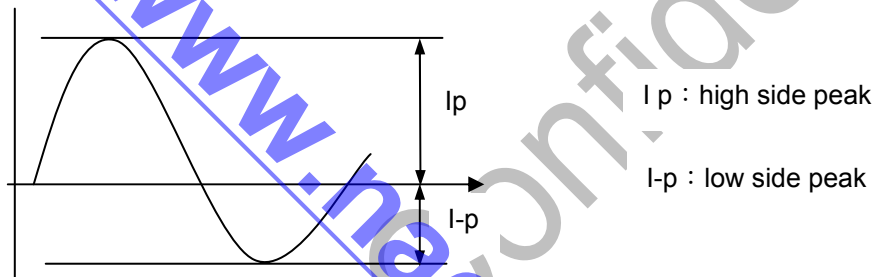

$$A : \text{The degrees of unbalance} = |I_p - I-p| / I_{rms} \times 100 (\%)$$

$$B : \text{The ratio of wave height} = I_p \text{ (or } I-p) / I_{rms}$$

[Note]

- *1) Table of specifications are definition of single lamp.
- *2) 1. Frequency in this range , the characteristics of electric and optics can maintain in $\pm 10\%$ except hues.
2. Lamp frequency of inverter may produce interference with horizontal synchronous frequency (or vertical synchronous frequency), and this may cause ripple noise on the display. Therefore, please adjust inverter frequency, and keep inverter as far from module as possible or use electronic shielding between inverter and module to avoid the interference.
- *3) 1. Starting Lamp Voltage: Vs = initial value Vs
2. Definition of starting lamp voltage means max. voltage of starting lamp. We suggest the inverter starting voltage greater than max. voltage of starting lamp to certify starting lamp stability.
- *4) Definition of the lamp life time : Luminance(L) under 50% of specification starting lamp voltage.
- *5) Test condition of Turn on and off life : Turn on and off lamp at IL=6.0mA and (Ta=25 \pm 5°C). The frequency is 30 sec.(on) on/ 30 sec. (off) and go on 100,000 times repeatedly.

4. INTERFACE CONNECTION

4.1 CN1

Connector type : 093F30-B0B01A

Pin No.	SYMBOL	FUNCTION
1	GND	Ground
2	Vcc	+3.3V Power
3	Vcc	+3.3V Power
4	NC	NC
5	NC	NC
6	NC	NC
7	NC	NC
8	RXIN0-	LVDS Signal(-)—channel 0
9	RXIN0+	LVDS Signal(+)—channel 0
10	GND	Ground
11	RXIN1-	LVDS Signal(-)—channel 1
12	RXIN1+	LVDS Signal(+)—channel 1
13	GND	Ground
14	RXIN2-	LVDS Signal(-)—channel 2
15	RXIN2+	LVDS Signal(+)—channel 2
16	GND	Ground
17	RXCLKIN-	LVDS Clock Signal(-)
18	RXCLKIN+	LVDS Clock Signal(+)
19	GND	Ground
20	NC	NC (6-bits / LVDS Signal(-)—channel 3)
21	NC	NC (6-bits / LVDS Signal(+)—channel 3)
22	GND	Ground
23	GND	Ground
24	NC	NC
25	NC	NC
26	NC	NC
27	NC	NC
27	NC	NC
29	NC	NC
30	NC	NC

5. INPUT SIGNAL(DE ONLY MODE)

5.1 Timing Specification

Item			Symbol	Min	Typ	Max	Unit
LVDS input signal sequence	CLK Frequency		fCLKin	39.05	45	51.42	MHz
	CLK Period		tCLKin	25.61	22.22	19.45	ns
LCD input signal sequence (Input LVDS Transmitter)	Horizontal	Horizontal Total Time	t _H	1160	1200	1240	tCLK
		Horizontal Effective Time	t _{HA}	1024	1024	1024	tCLK
		Horizontal Blank Time	t _{HB}	136	176	216	tCLK
	Vertical	Frame	f _V	55	60	65	Hz
		Vertical Total Time	t _V	612	625	638	t _H
		Vertical EffectiveTime	t _{VA}	600	600	600	t _H
		Vertical Blank Time	t _{VB}	12	25	38	t _H

5.2 Timing sequence(Timing chart)

5.2.1 Horizontal Timing Sequence

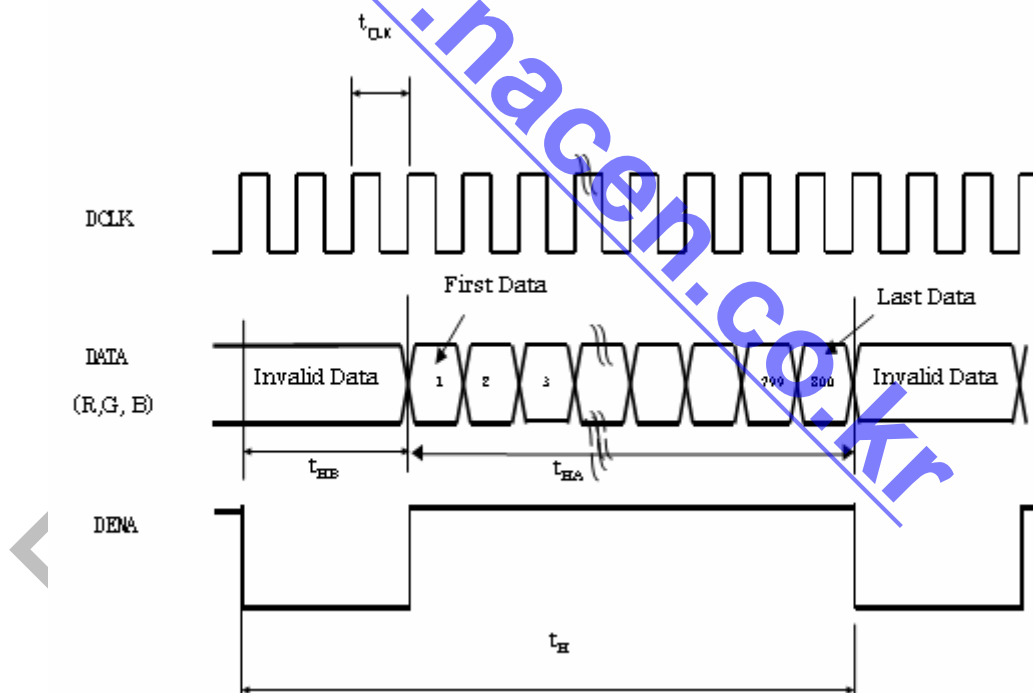

5.2.2 Vertical Timing Sequence

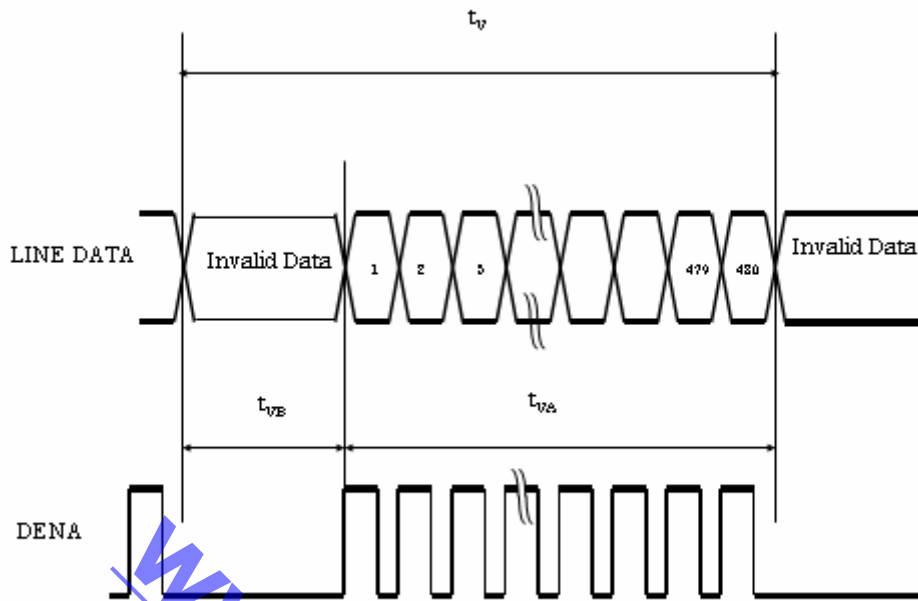

5.2.3 LVDS Input Data mapping

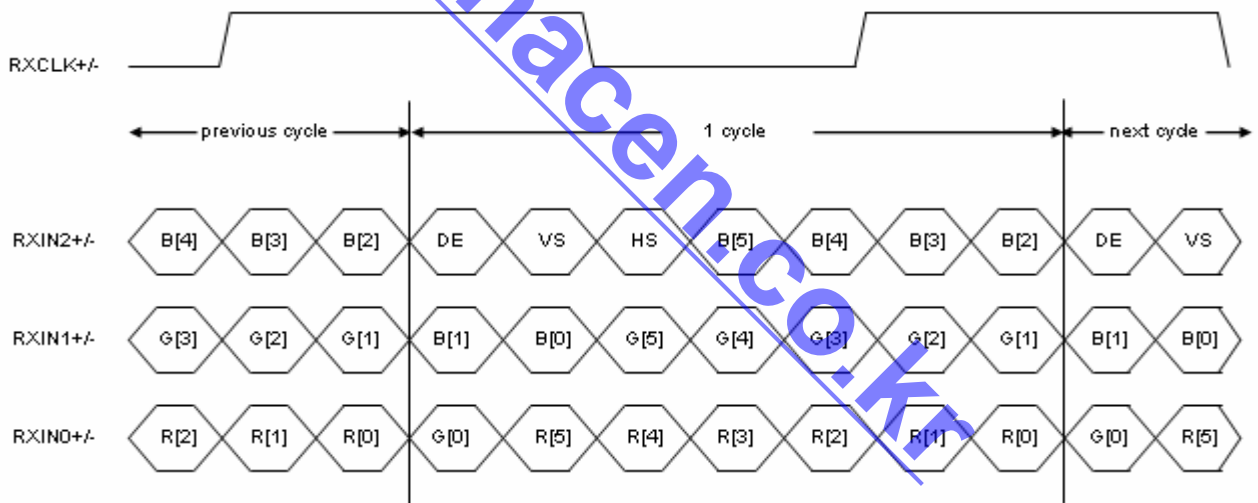

5.2.4 Color data assignment

COLOR	INPUT DATA	R DATA						G DATA						B DATA					
		R5	R4	R3	R2	R1	R0	G5	G4	G3	G2	G1	G0	B5	B4	B3	B2	B1	B0
		MSB					LSB	MSB					LSB	MSB					LSB
	BLACK	0	0	0	0	0	0	0	0	0	0	0	0	0	0	0	0	0	0
	RED(63)	1	1	1	1	1	1	0	0	0	0	0	0	0	0	0	0	0	0
BASIC	GREEN(63)	0	0	0	0	0	0	1	1	1	1	1	1	0	0	0	0	0	0
COLOR	BLUE(63)	0	0	0	0	0	0	0	0	0	0	0	0	1	1	1	1	1	1
	CYAN	0	0	0	0	0	0	1	1	1	1	1	1	1	1	1	1	1	1
	MAGENTA	1	1	1	1	1	1	0	0	0	0	0	0	1	1	1	1	1	1
	YELLOW	1	1	1	1	1	1	1	1	1	1	1	1	0	0	0	0	0	0
	WHITE	1	1	1	1	1	1	1	1	1	1	1	1	1	1	1	1	1	1
	RED(0)	0	0	0	0	0	0	0	0	0	0	0	0	0	0	0	0	0	0
	RED(1)	0	0	0	0	0	1	0	0	0	0	0	0	0	0	0	0	0	0
	RED(2)	0	0	0	0	1	0	0	0	0	0	0	0	0	0	0	0	0	0
RED																			
	RED(62)	1	1	1	1	1	0	0	0	0	0	0	0	0	0	0	0	0	0
	RED(63)	1	1	1	1	1	1	0	0	0	0	0	0	0	0	0	0	0	0
	GREEN(0)	0	0	0	0	0	0	0	0	0	0	0	0	0	0	0	0	0	0
	GREEN(1)	0	0	0	0	0	0	0	0	0	0	1	0	0	0	0	0	0	0
	GREEN(2)	0	0	0	0	0	0	0	0	0	0	1	0	0	0	0	0	0	0
GREEN																			
	GREEN(62)	0	0	0	0	0	0	1	1	1	1	1	0	0	0	0	0	0	0
	GREEN(63)	0	0	0	0	0	0	1	1	1	1	1	1	0	0	0	0	0	0
	BLUE(0)	0	0	0	0	0	0	0	0	0	0	0	0	0	0	0	0	0	0
	BLUE(1)	0	0	0	0	0	0	0	0	0	0	0	0	0	0	0	0	0	1
	BLUE(2)	0	0	0	0	0	0	0	0	0	0	0	0	0	0	0	0	1	0
BLUE																			
	BLUE(62)	0	0	0	0	0	0	0	0	0	0	0	0	1	1	1	1	1	0
	BLUE(63)	0	0	0	0	0	0	0	0	0	0	0	0	1	1	1	1	1	1

Remarks:

(1)Definition of Gray Scale

color(n) : n is series of Gray Scale. The more n value is the bright Gray Scale.

(2)Data:1-High,0-Low

6. BLOCK DIAGRAM

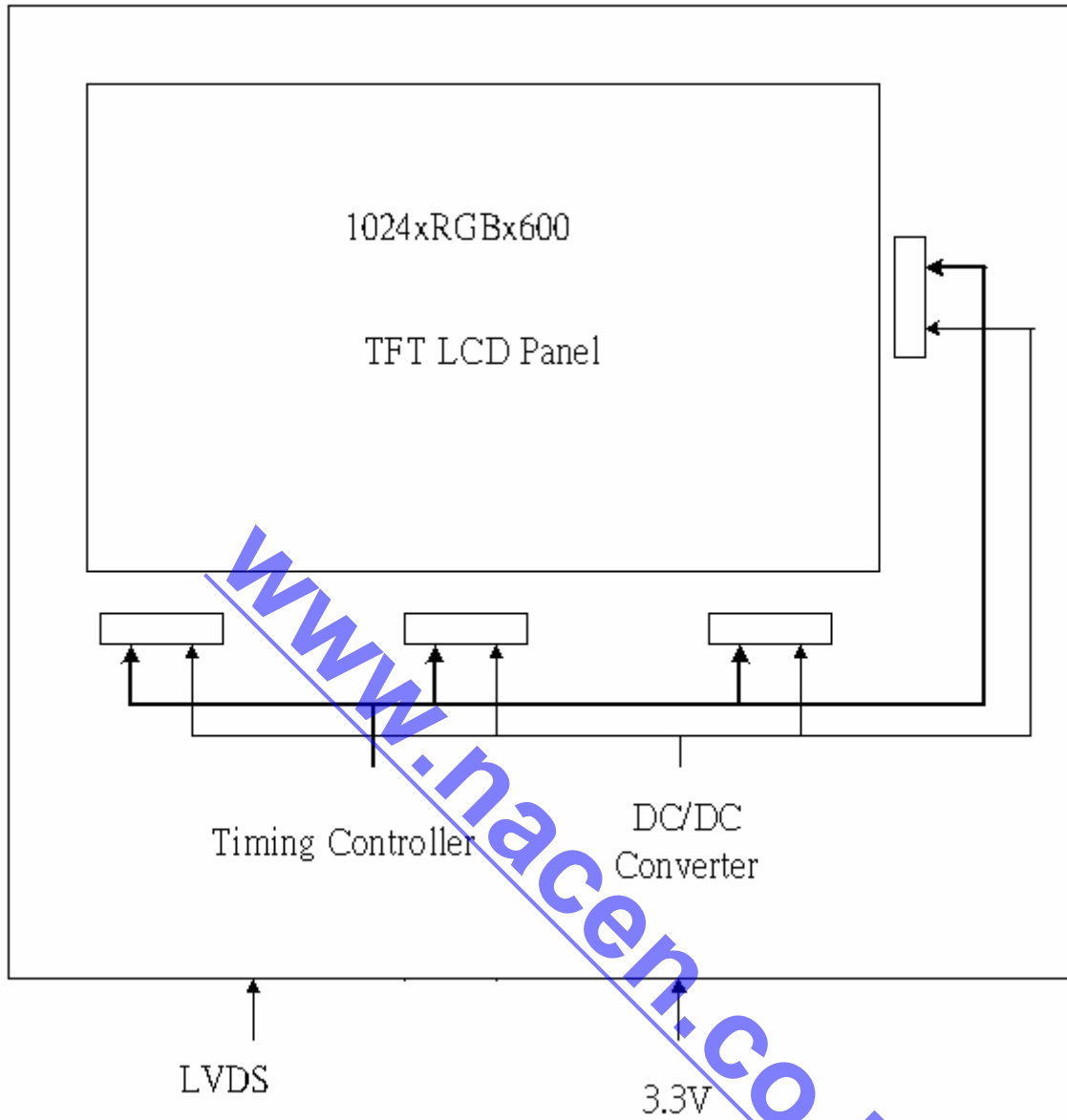

RB

7. MECHANICAL DIMENSION

7.1 Front Side

[Unit : mm]

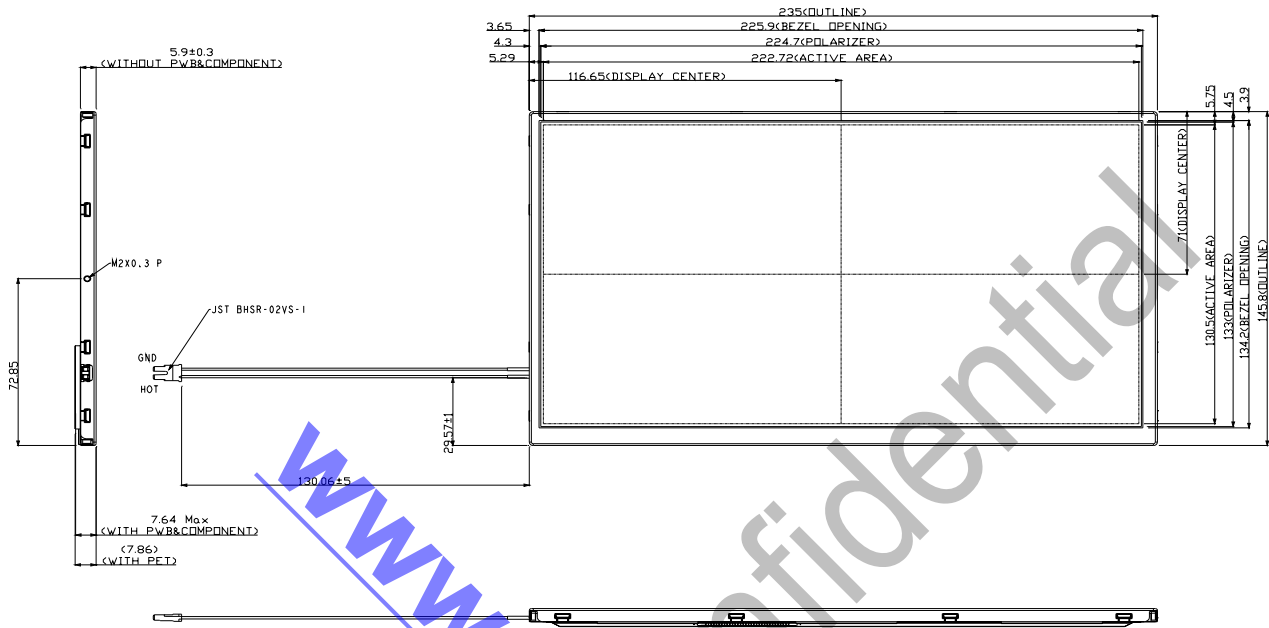

7.2 Rear Side

[Unit : mm]

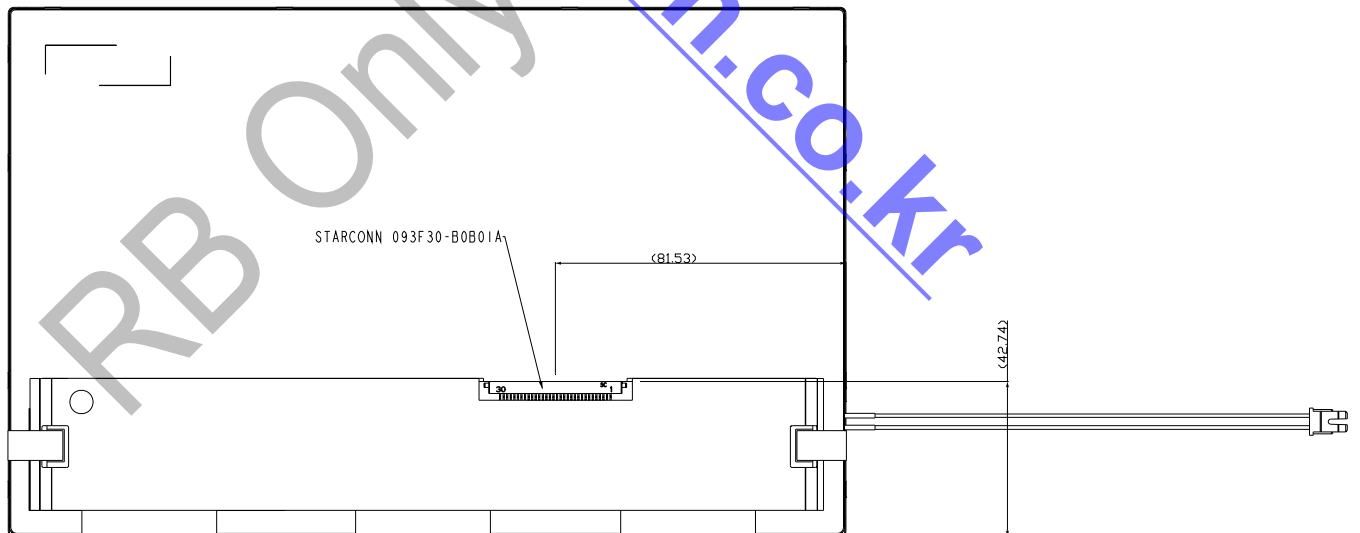

NOTE:

1. GENERAL TOLERANCE : ± 0.3mm
2. CCFL CONNETOR FOR BACKLIGHT TO BE SPECIFIED IS JST BHSR-02VS-1.
3. ALLOWED DEPTH OF USERHOLE SCREW INSERTION IS 1.5mm max.
4. 6 O'CLOCK DIRECTION IS THE OPTIMUM VIEWING ANGLW.

Remark : Un-indication tolerance is ±0.3mm

8. OPTICAL CHARACTERISTICS

Ta = 25°C, VCC=3.3V

ITEM		SYMBOL	CONDITION	MIN.	TYP.	MAX.	UNIT	Remarks
Contrast Ratio		CR	Point-5	--	400	--	--	*1)*2)*3)
Luminance(CEN)		Lw	Point-5	350	400	--	cd/m ²	*1)*3)
Luminance Uniformity		ΔL		70	80	-	%	*1)*3)
Response Time (White - Black)		Tr +Tf	Point-5			25	ms	*1)*3)*5)
Viewing Angle	Horizontal		CR ≥ 10 Point-5	110	140	--	°	*1)*2)*4)
	Vertical			100	110	--	°	*1)*2)*4)
Color Coordinate	White	Wx Wy	Point-5	0.273 0.289	0.313 0.329	0.353 0.369	--	*1)*3)
	Red	Rx Ry		0.548 0.280	0.588 0.320	0.628 0.360		
	Green	Gx Gy		0.270 0.531	0.310 0.571	0.350 0.611		
	Blue	Bx By		0.112 0.093	0.152 0.133	0.192 0.173		

Remarks :

*1) Measure condition : 25°C ± 2°C , 60 ± 10% RH , under 10 Lux in the dark room. BM-5A (TOPCON) , viewing angle 2° , VCC=3.3V.

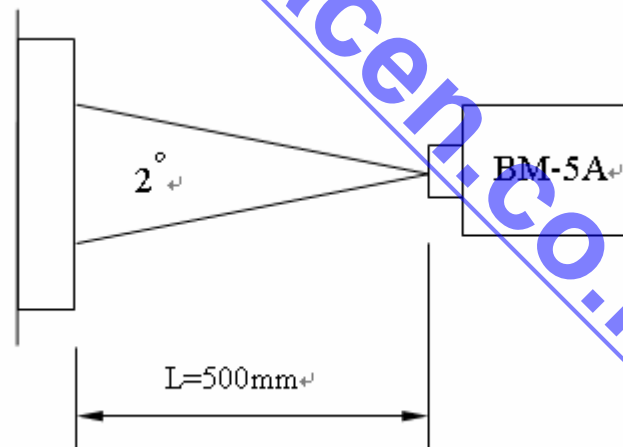

*2) Definition of contrast ratio :

Contrast Ratio (CR) = (White) Luminance of ON ÷ (Black) Luminance of OFF

- 3) Definition of luminance : Measure white luminance on the point 5 as figure8-1
 Definition of Luminance Uniformity: Measure white luminance on the point 1~9 as figure8-1

$$\Delta L = [L(\text{MIN})/L(\text{MAX})] \times 100$$

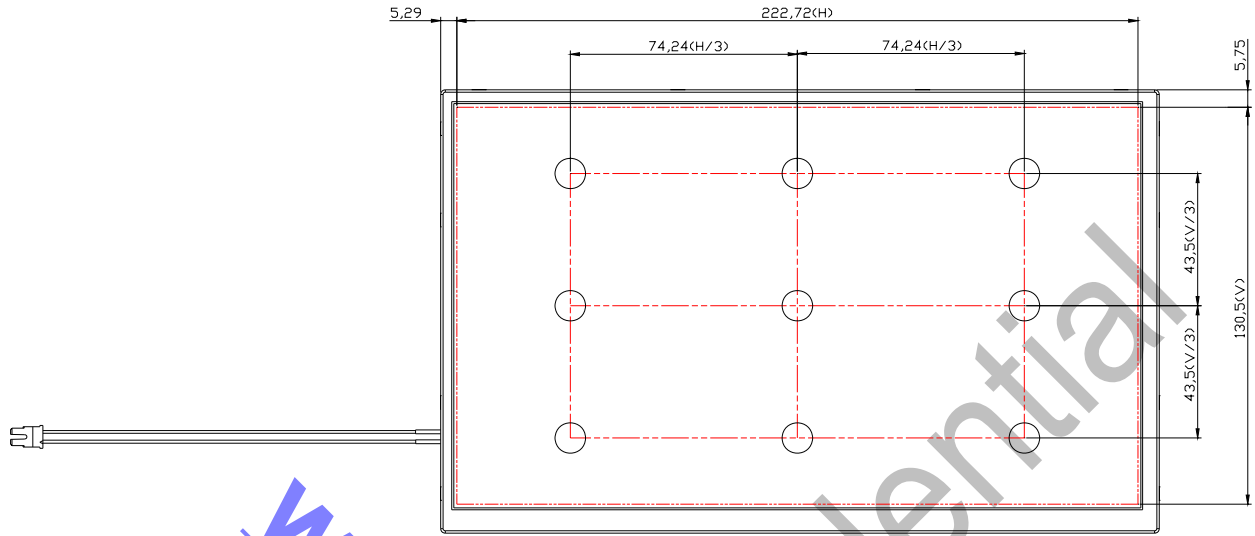

Fig8-1 Measuring point

- *4) Definition of Viewing Angle(θ, ψ), refer to Fig8-2 as below :

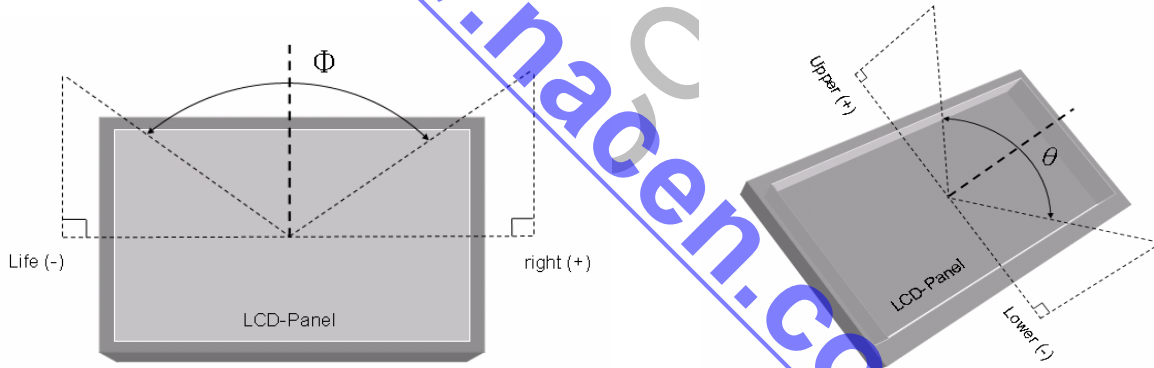

Fig8-2 Definition of Viewing Angle

- *5) Definition of Response Time.(White-Black)

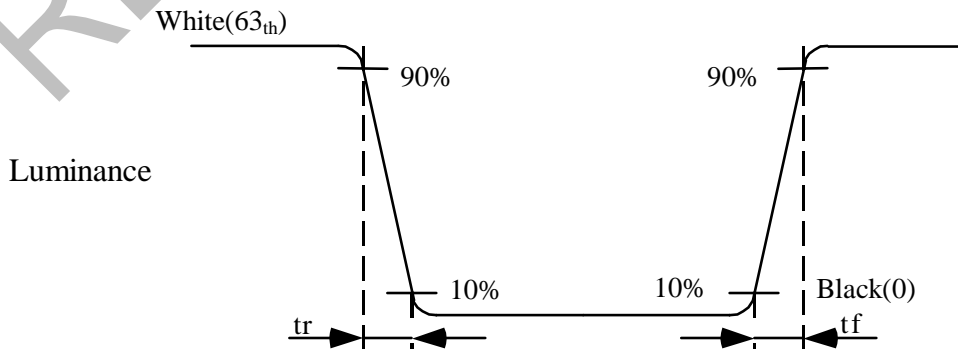

Fig8-3 Definition of Response Time(White-Black)

9. RELIABILITY TEST

9-1. Temperature and humidity

TEST ITEMS	CONDITIONS	REMARK
High Temperature Operation	85°C , 240Hrs	
High Temperature Storage	95°C , 240Hrs	
High Temperature High Humidity Operation	60°C , 90%RH , 240Hrs	No condensation
Low Temperature Operation	-30°C , 240Hrs	
Low Temperature Storage	-40°C , 240Hrs	
Thermal Shock	-30°C (0.5Hr) ~ 85°C(0.5Hr) , 200 cycles	

9.2. Shock and Vibration

TEST ITEMS	CONDITIONS
Shock (Non-operation)	<ul style="list-style-type: none"> ● Shock level:980m/s²(equal to 100G) ● Waveform:half sinusoidal wave,6ms. ● Number of shocks:one shock input in each direction of three mutually perpendicular axes for a total of three shock inputs.
Vibration (Non-operation)	<ul style="list-style-type: none"> ● Frequency range:8~33.3Hz ● Stroke:1.3mm ● Vibration:sinusoidal wave,perpendicularaxis(both x, z axis:2Hrs, y axis 4Hrs). ● Sweep:2.9G,33.3Hz-400Hz ● Cycle:15min

9.3. ESD Test

ITEM	CONDITION	REMARK
ESD	150pF , 330Ω , ±8KV&±15KV air & contact test	*1)
	200pF , 0Ω , ±250V contact test	*2)

Remarks :

*1) LCD glass and metal bezel

*2) IF connector pins

9.4 Judgment standard

The Judgment of the above test should be made as follow:

Pass:Normal display image with no obvious non-uniformity and no line defect.Partial transformation of the module parts should be ignored.

Fail:No display image,obvious non-uniform