

SOT-23



Pin Definition:

TS3809	TS3810
1. GND	1. GND
2. <u>RESET</u>	2. (RESET)
3. VCC	3. VCC

General Description

The TS3809/3810 series are used for microprocessor (μP) supervisory circuits to monitor the power supplies in μP and digital systems. They provide excellent circuit reliability and low cost by eliminating external components and adjustments when used with +5V, +3.3V, +3.0V, +2.5V powered circuits.

These circuits perform a single function: they assert a reset signal whenever the V_{CC} supply voltage declines below a preset threshold, keeping it asserted for at least 200ms after V_{CC} has risen above the reset threshold. Reset thresholds suitable for operation with a variety of supply voltages are available. TS3809/3810 series have push pull outputs. TS3809 series have an active low RESET output, while the TS3810 has an active high (RESET) output. The reset comparator is designed to ignore fast transients on V_{CC} , and the outputs are guaranteed to be in the correct logic state for V_{CC} down to 1.0V. Low supply current makes TS3809/3810 series ideal for use in portable equipment.

Features

- High Accurate: $\pm 2\%$
- Precision monitoring of +3V, +3.3V and +5V Power supply voltage
- Fully specified over temperature
- Available in three output configurations
- Push-Pull RESET low output (TS3809)
- Push-Pull (RESET) high output (TS3810)
- 200mS typ. Power-on reset pulse width
- 25 μS supply current
- Guaranteed reset valid to $V_{\text{CC}} = +1\text{V}$
- Power supply transient immunity

Applications

- Battery-operated systems and Controllers
- Intelligent instruments
- Critical μP and μC power monitoring
- Portable / Battery powered equipment
- Automotive

Ordering Information

Part No.	Package	Packing
TS3809CX _x RF	SOT-23	3Kpcs / 7" Reel
TS3810CX _x RF	SOT-23	3Kpcs / 7" Reel

Note: x is the threshold voltage type, option as:

A : 4.63V B : 4.38V C : 4.00V D : 3.08V
E : 2.93V F : 2.63V G : 2.25V

Typical Application Circuit

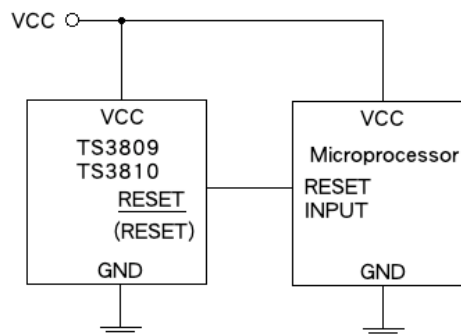

Absolute Maximum Rating

Parameter	Symbol	Maximum	Unit
Terminal Voltage (with respect to Gnd)	V_{CC}	GND - 0.3 to GND +6.5	V
<u>RESET</u> & (RESET) push-pull	V_{RESET}	GND - 0.3 to $V_{\text{CC}} + 0.3$	V
Input Current, V_{CC}	I_{CC}	20	mA
Output Current, <u>RESET</u> , (RESET)	I_{O}	5	mA
Power Dissipation	P_{D}	$(T_{\text{J}} - T_{\text{A}}) / \theta_{\text{JA}}$	mW
Operating Junction Temperature Range	$T_{\text{J,OPR}}$	-40 ~ +125	$^{\circ}\text{C}$
Storage Temperature Range	T_{STG}	-65 ~ +150	$^{\circ}\text{C}$
Lead Soldering Temperature (260 $^{\circ}\text{C}$)	T_{LEAD}	10	S

Thermal Performance

Parameter	Symbol	Maximum	Unit
Thermal Resistance from Junction to Case	θ_{JC}	110	$^{\circ}\text{C/W}$
Thermal Resistance from Junction to ambient	θ_{JA}	250	$^{\circ}\text{C/W}$

Note: θ_{JA} is measured the PCB copper area of approximately 1in^2 (Multi-layer). Needs to connect to V_{SS} pin.

Electrical Specification ($T_a = 25^{\circ}\text{C}$, unless otherwise specified.)

Parameter	Conditions	Symbol	Min	Typ	Max	Unit
Input Supply Voltage	$T_a = -40^{\circ}\text{C} \sim +85^{\circ}\text{C}$	V_{CC}	1.0	--	6	V
Supply Current	$V_{CC} = V_{TH} + 1\text{V}$	I_{CC}	--	25	35	μA
Reset Threshold	TS3809/3810CXA	V_{TH}	4.54	4.63	4.71	V
	TS3809/3810CXB		4.29	4.38	4.46	
	TS3809/3810CXC		3.92	4.00	4.08	
	TS3809/3810CXD		3.02	3.08	3.15	
	TS3809/3810CXE		2.87	2.93	3.00	
	TS3809/3810CXF		2.57	2.63	2.69	
	TS3809/3810CXG		2.20	2.25	2.30	
Reset Threshold Temperature Coefficient	$T_a = 0 \sim +85^{\circ}\text{C}$	V_{THT}	--	50	--	$\text{ppm}/^{\circ}\text{C}$
Set-up Time	$V_{CC} = 0 \sim (V_{TH} - 100\text{mV})$	T_{SET}	1	--	--	μs
VCC to Reset Delay	$V_{CC} = V_{TH} \sim (V_{TH} - 100\text{mV})$	T_{RD}	--	20	--	μs
Reset Active Timeout Period	$T_a = 0 \sim +85^{\circ}\text{C}$	T_{DELAY}	140	200	260	mS
RESET Output (TS3809) Voltage Low	$1.8\text{V} < V_{CC} < V_{TH(\text{MAX})}$, $I_{SINK} = 1.2\text{mA}$	V_{OL}	--	--	0.3	V
	$1.2\text{V} < V_{CC} < 1.8\text{V}$, $I_{SINK} = 50\mu\text{A}$					
RESET Output (TS3809) Voltage High	$V_{CC} > V_{TH(\text{MAX})}$, $I_{SOURCE} = 500\mu\text{A}$	V_{OH}	0.8 VCC	--	--	V
(RESET) Output (TS3810) Voltage Low	$V_{CC} > V_{TH(\text{MAX})}$, $I_{SINK} = 1.2\text{mA}$	V_{OL}	--	--	0.3	V
(RESET) Output (TS3810) Voltage High	$1.8\text{V} < V_{CC} < V_{TH(\text{MAX})}$, $I_{SOURCE} = 500\mu\text{A}$	V_{OH}	0.8 VCC	--	--	V
	$1.2\text{V} < V_{CC} < 1.8\text{V}$, $I_{SOURCE} = 150\mu\text{A}$					
Hysteresis at Vcc	Input Voltage	V_{HVS}	--	40	--	mV

Block Diagram

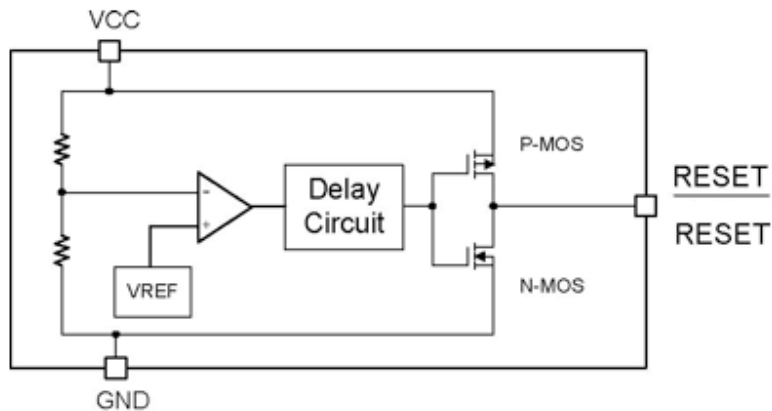

Device Top Marking Information

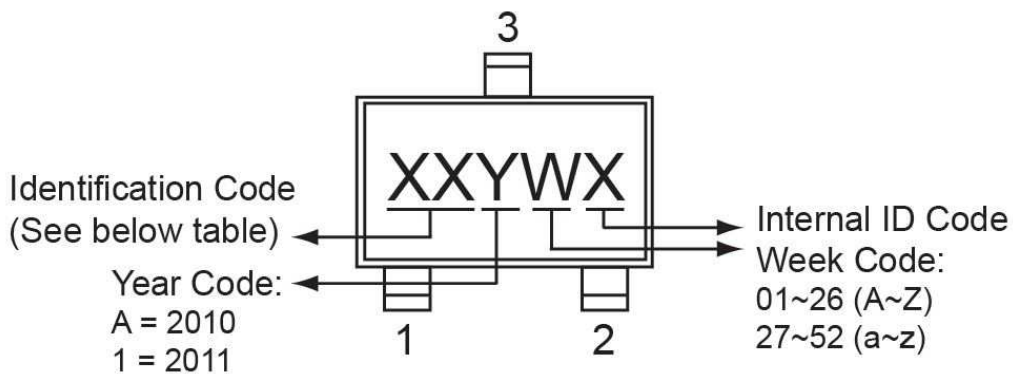

Part No.	Identification Code	Part No.	Identification Code
TS3809CXA	CA	TS3810CXA	CH
TS3809CXB	CB	TS3810CXB	CI
TS3809CXC	CC	TS3810CXC	CJ
TS3809CXD	CD	TS3810CXD	CK
TS3809CXE	CE	TS3810CXE	CL
TS3809CXF	CF	TS3810CXF	CM
TS3809CXG	CG	TS3810CXG	CN

Application Information

Negative-Going VCC transients in addition to issuing a reset to the μP during power-up, power-down, and brownout conditions, the TS3809/3810 are relatively immune to short-duration negative-going Vcc transients (glitches).

The TS3809/3810 do not generate a reset pulse. The graph was generated using a negative going pulse applied to Vcc, starting 0.5V above the actual reset threshold and ending below it by the magnitude indicated (reset comparator overdrive). The graph indicates the maximum pulse width a negative going Vcc transient can have without causing a reset pulse. As the magnitude of the transient increases (goes farther below the reset threshold), the maximum allowable pulse width decreases. Typically, a Vcc transient that goes 100mV below the reset threshold and lasts 20 μS or less will not cause a reset pulse. A 0.1 μF bypass capacitor mounted as close as possible to the Vcc pin provides additional transient immunity.

Function Description

A microprocessor's (μP 's) reset input starts the μP in a known state. The TS3809/3810 assert reset to prevent code-execution errors during power-up, power-down, or brownout conditions. They assert a reset signal whenever the Vcc supply voltage declines below a preset threshold, keeping it asserted for at least 140ms after Vcc has risen above the reset threshold. The TS3809/3810 have a push-pull output stage.

Ensuring a Valid Reset Output Down to Vcc=0

RESET is guaranteed to be a logic low for VCC > 1.0V. Once VCC exceeds the reset threshold, an internal timer keeps RESET low for the reset timeout period; after this interval, RESET goes high. If a brownout condition occurs (VCC dips below the reset threshold), RESET goes low. Any time VCC goes below the reset threshold, the internal timer resets to zero, and RESET goes low. The internal timer starts after VCC returns above the reset threshold, and RESET remains low for the reset timeout period. When Vcc falls below 1V, the TS3809/3810 reset output no longer sinks current - it becomes an open circuit. Therefore, high impedance CMOS logic input connected to reset can drift to undetermined voltages. This presents no problem in most applications since most μP and other circuitry is inoperative with Vcc below 1V. However, in applications where reset must be valid down to 0V, adding a pull down resistor to reset causes and stray leakage currents to flow to ground, holding reset low (Figure 2.) R1's value is not critical; 100K is large enough not to load reset and small enough to pull RESET to ground. For the TS3809/3810 if reset is required to remain valid for Vcc<1V.

Benefits of Highly Accurate Reset Threshold

Most μP supervisor ICs has reset threshold voltages between 5% and 10% below the value of nominal supply voltages. This ensures a reset will not occur within 5% of the nominal supply, but will occur when the supply is 10% below nominal. When using ICs rated at only the nominal supply $\pm 5\%$, this leaves a zone of uncertainty where the supply is between 5% and 10% low, and where the reset may or may not be asserted

Timing Diagram

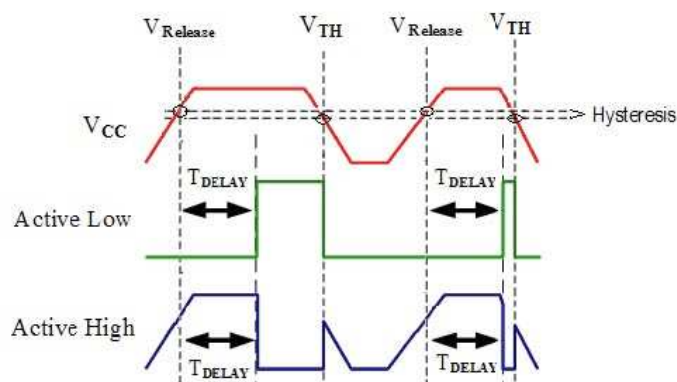

Electrical Characteristics Curve

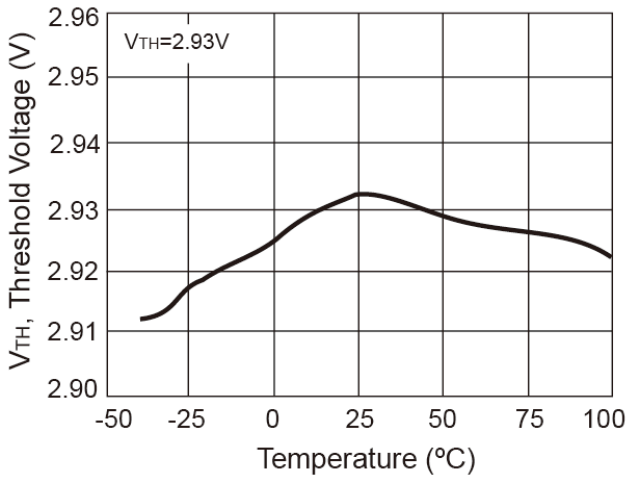

Figure 1. Threshold Voltage vs. Temperature

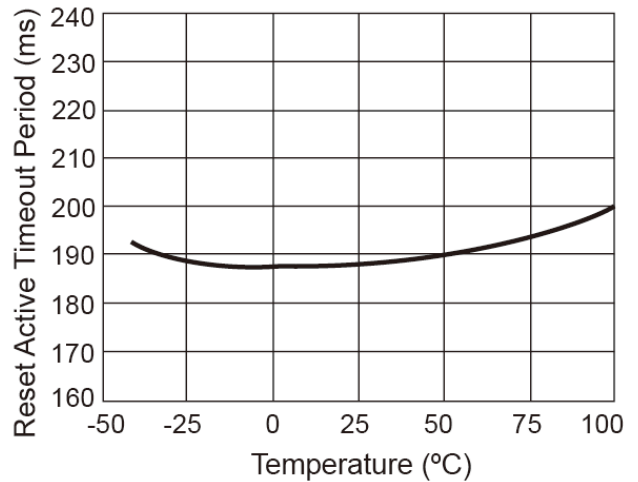

Figure 2. T_{DELAY} vs. Temperature

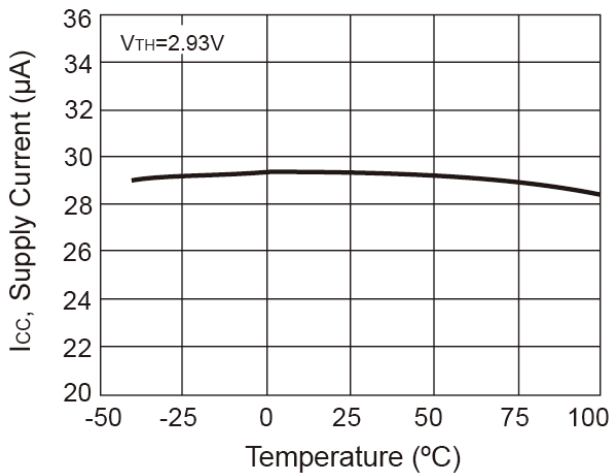

Figure 3. Supply Current vs. Temperature

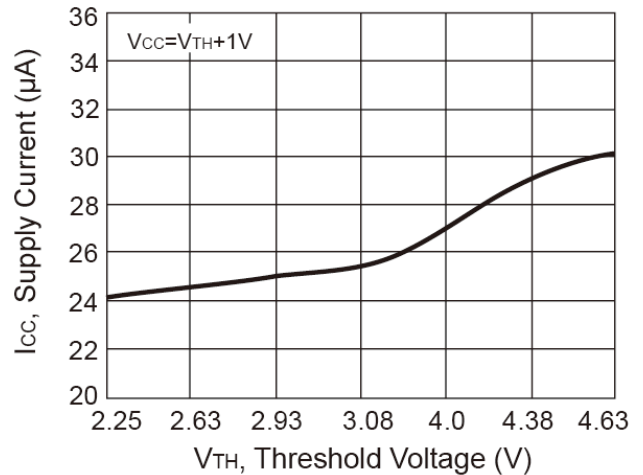

Figure 4. Supply Current vs. Threshold Voltage

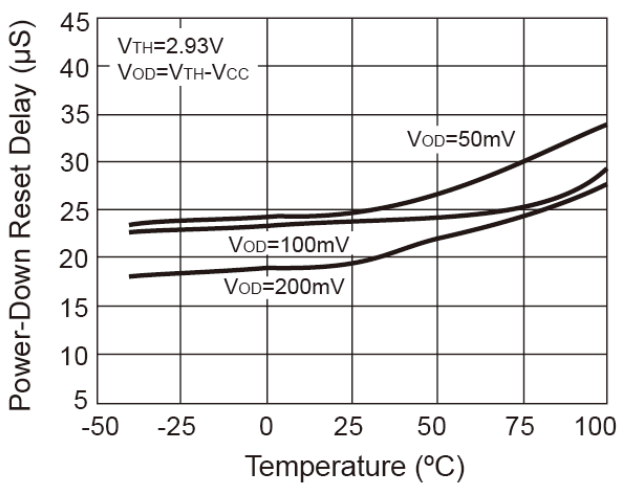

Figure 5. Power-Down T_{DELAY} vs. Temperature

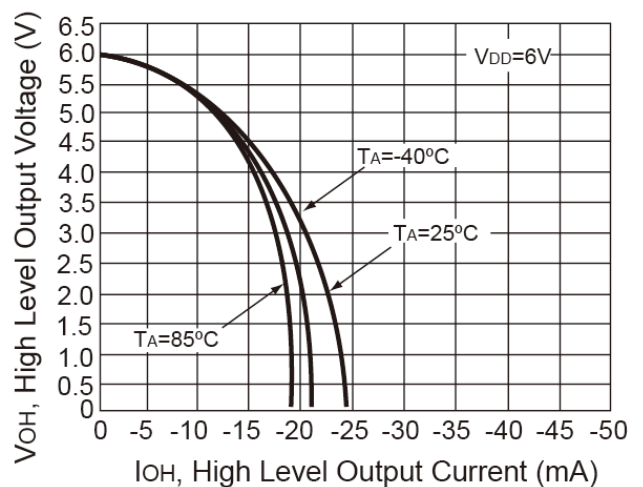
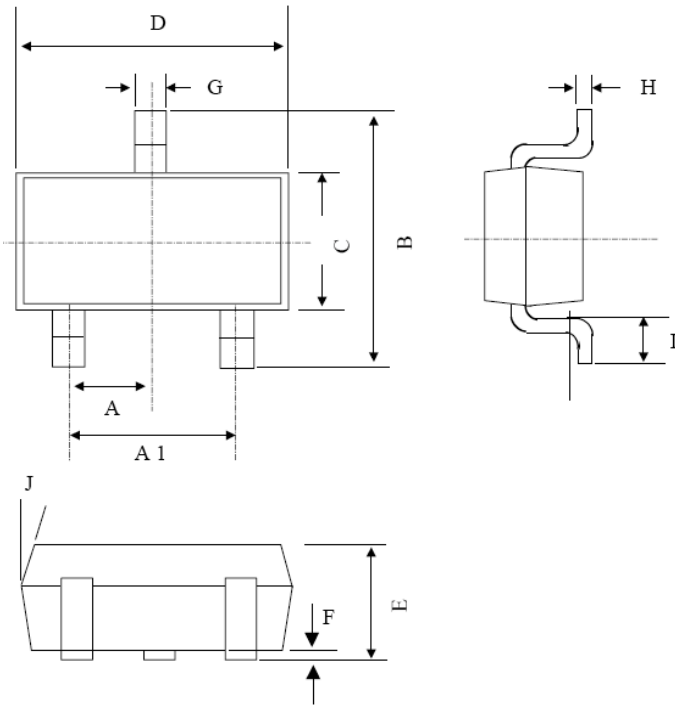

Figure 6. Output Voltage vs. Output Current

SOT-23 Mechanical Drawing



SOT-23 DIMENSION				
DIM	MILLIMETERS		INCHES	
	MIN	MAX	MIN	MAX.
A	0.95 BSC		0.037 BSC	
A1	1.9 BSC		0.074 BSC	
B	2.60	3.00	0.102	0.118
C	1.40	1.70	0.055	0.067
D	2.80	3.10	0.110	0.122
E	1.00	1.30	0.039	0.051
F	0.00	0.10	0.000	0.004
G	0.35	0.50	0.014	0.020
H	0.10	0.20	0.004	0.008
I	0.30	0.60	0.012	0.024
J	5°	10°	5°	10°

Notice

Specifications of the products displayed herein are subject to change without notice. TSC or anyone on its behalf, assumes no responsibility or liability for any errors or inaccuracies.

Information contained herein is intended to provide a product description only. No license, express or implied, to any intellectual property rights is granted by this document. Except as provided in TSC's terms and conditions of sale for such products, TSC assumes no liability whatsoever, and disclaims any express or implied warranty, relating to sale and/or use of TSC products including liability or warranties relating to fitness for a particular purpose, merchantability, or infringement of any patent, copyright, or other intellectual property right.

The products shown herein are not designed for use in medical, life-saving, or life-sustaining applications. Customers using or selling these products for use in such applications do so at their own risk and agree to fully indemnify TSC for any damages resulting from such improper use or sale.