

1. Dimensions:

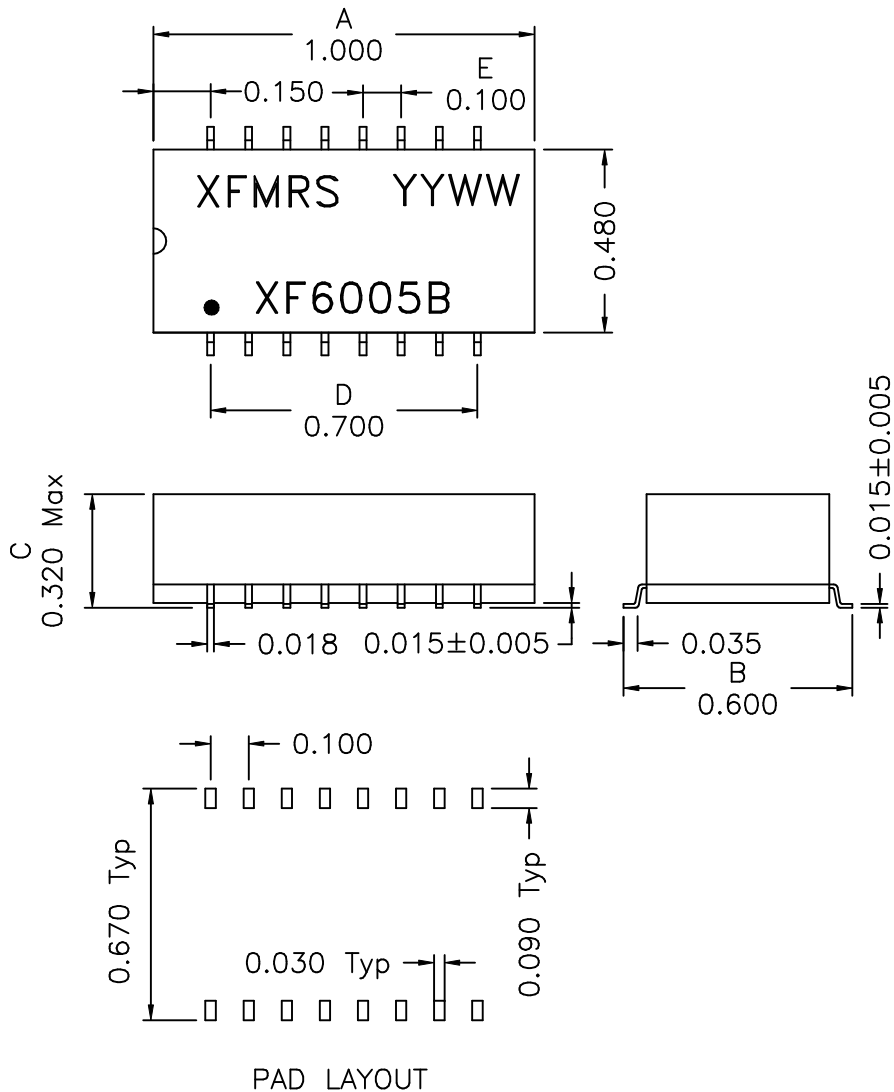

2. Schematic:

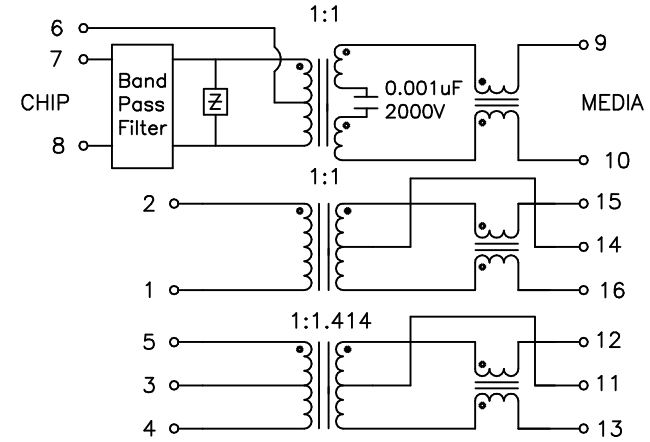

SIDACTOR: P0300SA TECCOR ELECTROINCS, INC.

3. Electrical Specifications: @25°C

line withstand voltage: 1500Vrms

TUT

Insertion Loss: (6.0MHz-9.0MHz) -3.0dB Max

Return Loss: -12dB Min (6MHz-9MHz) match to 100 Ohms

Attenuation @1MHz -80dB Min

@27MHz -70dB Min

Cut-off frequency: Lower Band

5.2-5.8MHz

10BASE-T

OCL: 2-1, 5-4 200uH Typ @100KHz 100mV

INSERTION LOSS: 1.0dB Max @5-10MHz

RETURN LOSS: 18dB Min @5-10MHz

DOC. REV: A/1

XFMR INC.		Title: BANDPASS FILTER	
UNLESS OTHERWISE SPECIFIED		P/N: XF6005B	REV. A
TOLERANCES: .xxx ±0.010		DWN. 廖玉坤	Apr-12-01
Dimensions in Inch		CHK. 李清儿	Apr-12-01
SHT 1 OF 2		APP. BW	Apr-12-01