

JPP-21R Series

Units to 1 GHz / High Data Bandwidth / Differential ECL/TTL Compatible Drive / Hi-Rel Package

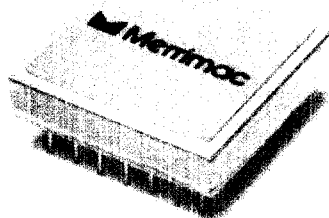
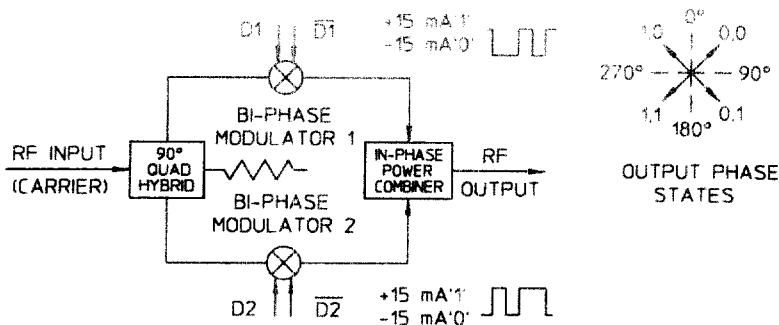

PRINCIPAL SPECIFICATIONS

Model Number	Center Frequency, f_0 , MHz	RF Input Bandwidth	Amplitude Balance, dB, Max.	Phase Balance at Center, f_0 Typ. Max.	Phase Balance at 10% Band Limits Typ. Max.	Insertion Loss, dB, Max.
JPP-21R-***B	10 - 200	10% of f_0	0.5	$\pm 1^\circ$ $\pm 2^\circ$	$\pm 2^\circ$ $\pm 4^\circ$	6
JPP-21R-***B	200 - 1000	10% of f_0	1.0	$\pm 1^\circ$ $\pm 3^\circ$	$\pm 3^\circ$ $\pm 5^\circ$	9

For complete Model Number replace *** with desired Center Frequency, f_0 in MHz.

General Notes:

- Units in the JPP-21R series of Quadraphase Modulators are composed of two biphas modulators, a 90° quadrature hybrid and an in-phase power combiner.
- These devices are generally used in systems to generate QPSK coded signals. The units accept two differential data inputs each of which independently biphas modulates an RF carrier. These are then combined to produce a quadraphase output of 0, 90, 180 and 270 degrees. Differential drive allows easy interface with ECL/TTL drivers.
- Merrimac Quadraphase Modulators comply with the relevant sections of MIL-M-28837 and may be supplied screened for compliance with additional specifications for military and space applications requiring the highest reliability.

GENERAL SPECIFICATIONS

RF Impedance:	50 Ω nom.
VSWR:	1.5:1 max.
RF Input Level:	0 dBm nom.
Data Bandwidth:	>100 MHz nom.
Data Signal Levels:	Logic 1: +15 mA nom. Logic 0: -15 mA nom.
Weight, nominal:	0.32 oz (9 g)
Operating Temperature:	-55° to +85°C

Outline of R-Size Meri-Pac™

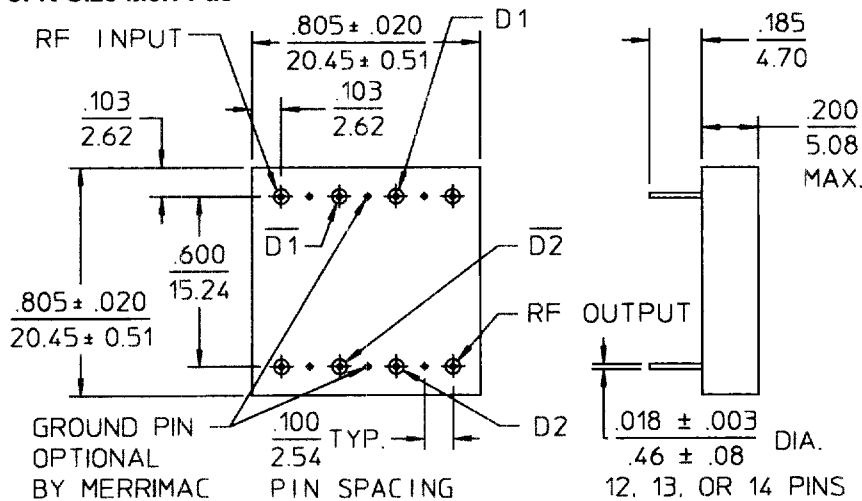

Modulation Sequence		
Data Ports 1 2	0, 0	ref. 0°
	1, 0	-270°
	1, 1	-180°
	0, 1	-90°

NOTES

- Tolerance on 3 place decimals $\pm .010$ (.25) except as noted.
- Dimensions in inches over millimeters.
- Dimensions marked with * apply only at body
- All unmarked pins are case ground