

μA759 • μA77000 Power Operational Amplifiers

Linear Division Operational Amplifiers

Description

The μA759 and μA77000 are high performance monolithic operational amplifiers constructed using the Fairchild Planar Epitaxial process. The μA759 provides 325 mA and the μA77000 provides 250 mA output current and feature small signal characteristics better than the μA741. The amplifiers are designed to operate from a single or dual power supply with the input common mode range including the negative supply. The high gain and high output power provide superior performance whenever an operational amplifier is needed. The μA759 and μA77000 employ internal current limiting, thermal shutdown, and safe-area compensation making them essentially indestructible. These amplifiers are intended for a wide range of applications including voltage regulators, audio amplifiers, servo amplifiers, and power drivers.

• Output Current

μA759 — 325 mA Minimum

μA77000 — 250 mA Minimum

- Internal Short Circuit Current Limiting
- Internal Thermal Overload Protection
- Internal Output Transistors Safe-Area Protection
- Input Common Mode Voltage Range Includes Ground Or Negative Supply

Absolute Maximum Ratings

Storage Temperature Range

Metal Can -65°C to +175°C

Power Watt -65°C to +150°C

Operating Junction Temperature Range

Extended (μA759M) -55 to +150°C

Commercial (μA759C, μA77000C) 0°C to +125°C

Lead Temperature

Metal Can (soldering, 60 s) 300°C

Power Watt (soldering, 10 s) 265°C

Internal Power Dissipation¹ Internally Limited

Supply Voltage ± 18 V

Differential Input Voltage 30 V

Input Voltage² ± 15 V

Notes

1. Although the internal power dissipation is limited, the junction temperature must be kept below the maximum specified temperature in order to meet data sheet specifications. To calculate the maximum junction temperature or heat sink required, use the thermal resistance values which follow the Electrical Characteristics Table.
2. For a supply voltage less than 30 V between V+ and V-, the absolute maximum input voltage is equal to the supply voltage.

Connection Diagram 8-Lead Metal Package (Top View)

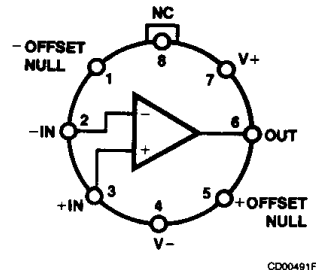

CD00491F

Lead 4 connected to case.

Order Information

Device Code	Package Code	Package Description
μA759HM	5W	Metal
μA759HC	5W	Metal

Connection Diagram TO-202 Package (Top View)

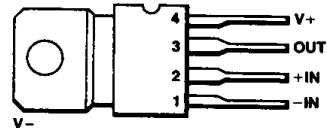

CD00500F

Order Information

Device Code	Package Code	Package Description
μA759U1C	8Z	Power Watt
μA77000U1C	8Z	Power Watt

Equivalent Circuit

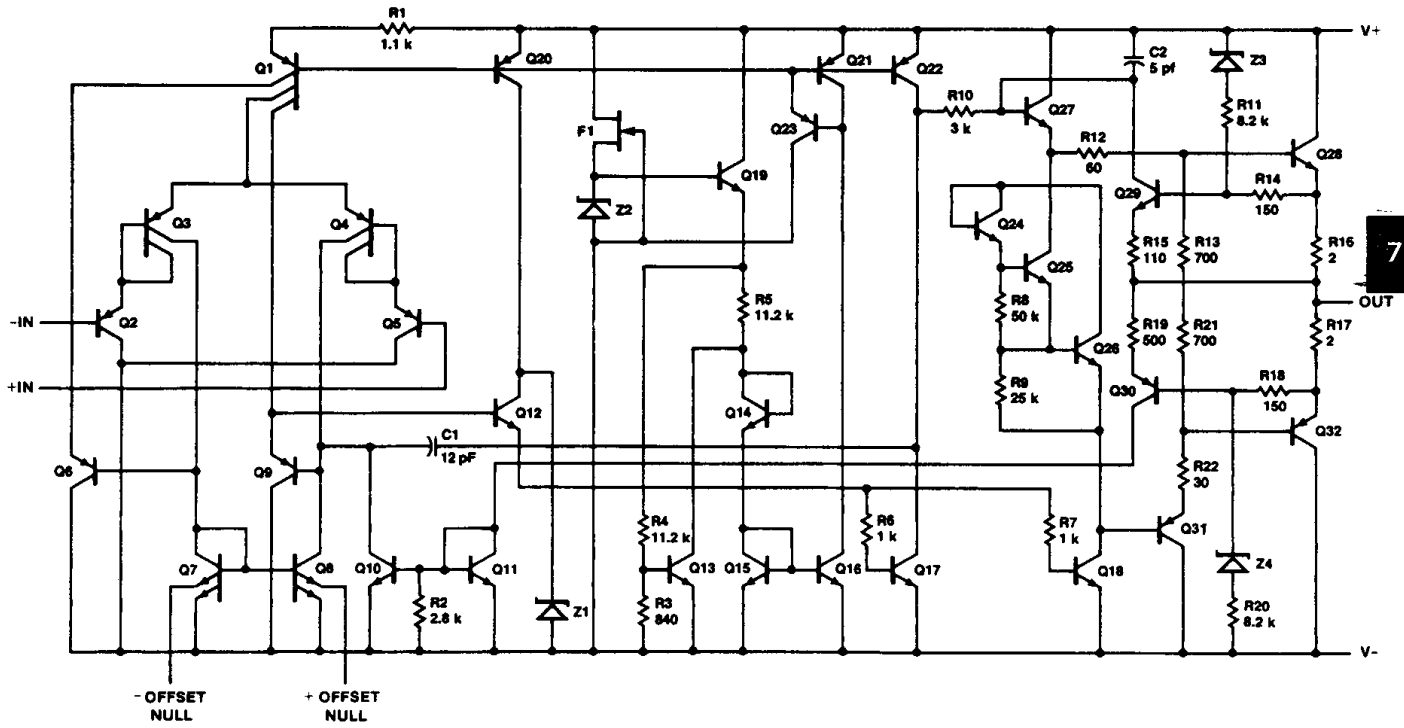

7

EQ00021F

Note
All resistor values in ohms.

μA759

Electrical Characteristics $T_J = 25^\circ\text{C}$, $V_{CC} = \pm 15\text{ V}$, unless otherwise specified.

Symbol	Characteristic	Condition	Min	Typ	Max	Unit
V_{IO}	Input Offset Voltage	$R_S \leq 10\text{ k}\Omega$		1.0	3.0	mV
I_{IO}	Input Offset Current			5.0	30	nA
I_{IB}	Input Bias Current			50	150	nA
Z_I	Input Impedance		0.25	1.5		MΩ
I_{CC}	Supply Current			12	18	mA
V_{IR}	Input Voltage Range		+13 to V-	+13 to V-		V
I_{OS}	Output Short Circuit Current	$ V_{CC} - V_O = 30\text{ V}$		±200		mA
$I_{O\text{ PEAK}}$	Peak Output Current	$3.0\text{ V} \leq V_{CC} - V_O \leq 10\text{ V}$	±325	±500		mA
A_{VS}	Large Signal Voltage Gain	$R_L \geq 50\ \Omega$, $V_O = \pm 10\text{ V}$	50	200		V/mV
TR	Transient Response	Rise time	$R_L = 50\ \Omega$, $A_V = 1.0$		300	ns
		Overshoot			5.0	%
SR	Slew Rate	$R_L = 50\ \Omega$, $A_V = 1.0$		0.6		V/μs
BW	Bandwidth	$A_V = 1.0$		1.0		MHz

The following specifications apply for $-55^\circ\text{C} \leq T_J \leq +150^\circ\text{C}$

V_{IO}	Input Offset Voltage	$R_S \leq 10\text{ k}\Omega$			4.5	mV
I_{IO}	Input Offset Current				60	nA
I_{IB}	Input Bias Current				300	nA
CMR	Common Mode Rejection	$R_S \leq 10\text{ k}\Omega$	80	100		dB
PSRR	Power Supply Rejection Ratio	$R_S \leq 10\text{ k}\Omega$	80	100		dB
A_{VS}	Large Signal Voltage Gain	$R_L \geq 50\ \Omega$, $V_O = \pm 10\text{ V}$	25	200		V/mV
V_{OP}	Output Voltage Swing	$R_L = 50\ \Omega$	±10	±12.5		V

μA759C

Electrical Characteristics $T_J = 25^\circ\text{C}$, $V_{CC} = \pm 15\text{ V}$, unless otherwise specified.

Symbol	Characteristic	Condition	Min	Typ	Max	Unit
V_{IO}	Input Offset Voltage	$R_S \leq 10\text{ k}\Omega$		1.0	6.0	mV
I_{IO}	Input Offset Current			5.0	50	nA
I_{IB}	Input Bias Current			50	250	nA
Z_I	Input Impedance		0.25	1.5		MΩ
I_{CC}	Supply Current			12	18	mA
V_{IR}	Input Voltage Range		+13 to V^-	+13 to V^-		V
I_{OS}	Output Short Circuit Current	$ V_{CC} - V_O = 30\text{ V}$		±200		mA
$I_{O\text{ PEAK}}$	Peak Output Current	$3.0\text{ V} \leq V_{CC} - V_O \leq 10\text{ V}$	±325	±500		mA
A_{VS}	Large Signal Voltage Gain	$R_L \geq 50\ \Omega$, $V_O = \pm 10\text{ V}$	25	200		V/mV
TR	Transient Response	Rise time	$R_L = 50\ \Omega$, $A_V = 1.0$	300		ns
		Overshoot		10		%
SR	Slew Rate	$R_L = 50\ \Omega$, $A_V = 1.0$		0.5		V/μs
BW	Bandwidth	$A_V = 1.0$		1.0		MHz

7

The following specifications apply for $0^\circ \leq T_J \leq +125^\circ\text{C}$

V_{IO}	Input Offset Voltage	$R_S \leq 10\text{ k}\Omega$			7.5	mV
I_{IO}	Input Offset Current				100	nA
I_{IB}	Input Bias Current				400	nA
CMR	Common Mode Rejection	$R_S \leq 10\text{ k}\Omega$	70	100		dB
PSRR	Power Supply Rejection Ratio	$R_S \leq 10\text{ k}\Omega$	80	100		dB
A_{VS}	Large Signal Voltage Gain	$R_L \geq 50\ \Omega$, $V_O = \pm 10\text{ V}$	25	200		V/mV
V_{OP}	Output Voltage Swing	$R_L = 50\ \Omega$	±10	±12.5		V

μA77000

Electrical Characteristics $T_J = 25^\circ\text{C}$, $V_{CC} = \pm 15\text{ V}$, unless otherwise specified.

Symbol	Characteristic	Condition	Min	Typ	Max	Unit
V_{IO}	Input Offset Voltage	$R_S \leq 10\text{ k}\Omega$		1.0	8.0	mV
I_{IO}	Input Offset Current			5.0	50	nA
I_{IB}	Input Bias Current			50	250	nA
Z_I	Input Impedance		0.25	1.5		M Ω
I_{CC}	Supply Current			12	18	mA
V_{IR}	Input Voltage Range		+13 to V-	+13 to V-		V
I_{OS}	Output Short Circuit Current	$ V_{CC} - V_O = 30\text{ V}$		± 200		mA
$I_{O\text{ PEAK}}$	Peak Output Current	$3.0\text{ V} \leq V_{CC} - V_O \leq 10\text{ V}$	± 250	± 400		mA
A_{VS}	Large Signal Voltage Gain	$R_L \geq 50\ \Omega$, $V_O = \pm 10\text{ V}$	25	200		V/mV
TR	Transient Response	Rise time	$R_L = 50\ \Omega$, $A_V = 1.0$	300		ns
		Overshoot		10		%
SR	Slew Rate	$R_L = 50\ \Omega$, $A_V = 1.0$		0.5		V/ μs
BW	Bandwidth	$A_V = 1.0$		1.0		MHz

The following specifications apply for $0^\circ \leq T_J \leq +125^\circ\text{C}$

V_{IO}	Input Offset Voltage	$R_S \leq 10\text{ k}\Omega$			10	mV
I_{IO}	Input Offset Current				100	nA
I_{IB}	Input Bias Current				400	nA
CMR	Common Mode Rejection	$R_S \leq 10\text{ k}\Omega$	70	100		dB
PSRR	Power Supply Rejection Ratio	$R_S \leq 10\text{ k}\Omega$	80	100		dB
A_{VS}	Large Signal Voltage Gain	$R_L \geq 50\ \Omega$, $V_O = \pm 10\text{ V}$	25	200		V/mV
V_{OP}	Output Voltage Swing	$R_L = 50\ \Omega$	± 10	± 12.5		V

Package	Typ	Max	Typ	Max
	θ_{JC} °C/W	θ_{JC} °C/W	θ_{JA} °C/W	θ_{JA} °C/W
Power Watt (U1)	8.0	12	75	80
Metal Can (H)	30	40	120	150

$$P_{D\text{Max}} = \frac{T_{J\text{Max}} - T_A}{\theta_{JC} + \theta_{CA}} \text{ or}$$

$$= \frac{T_{J\text{Max}} - T_A}{\theta_{JA}} \text{ (Without a heat sink)}$$

$$\theta_{CA} = \theta_{CS} + \theta_{SA}$$

Solving T_J :

$$T_J = T_A + P_D(\theta_{JC} + \theta_{CA}) \text{ or}$$

$$= T_A + P_D\theta_{JA} \text{ (Without a heat sink)}$$

Where:

- T_J = Junction Temperature
- T_A = Ambient Temperature
- P_D = Power Dissipation
- θ_{JA} = Junction to ambient thermal resistance
- θ_{JC} = Junction to case thermal resistance
- θ_{CA} = Case to ambient thermal resistance
- θ_{CS} = Case to heat sink thermal resistance
- θ_{SA} = Heat sink to ambient thermal resistance

Mounting Hints

Metal Can Package (μA759HC/μA759HM)

The μA759 in the 8-Lead TO-99 metal can package must be used with a heat sink. With ±15 V power supplies, the μA759 can dissipate up to 540 mW in its quiescent (no load) state. This would result in a 100°C rise in chip temperature to 125°C (assuming a 25°C ambient temperature). In order to avoid this problem, it is advisable to use either a slip on or stud mount heat sink with this package. If a stud mount heat sink is used, it may be necessary to use insulating washers between the stud and the chassis because the case of the μA759 is internally connected to the negative power supply terminal.

Power Watt Package (μA759U1C/μA77000U1C)

The μA759U1C and μA77000U1C are designed to be attached by the tab to a heat sink. This heat sink can be either one of the many heat sinks which are commercially available, a piece of metal such as the equipment chassis, or a suitable amount of copper foil as on a double sided PC board. The important thing to remember is that the negative power supply connection to the op amp must be made through the tab. Furthermore, adequate heat sinking must be provided to keep the chip temperature below 125°C under worst case load and ambient temperature conditions.

Typical Performance Curves

Frequency Response For Various Closed Loop Gains

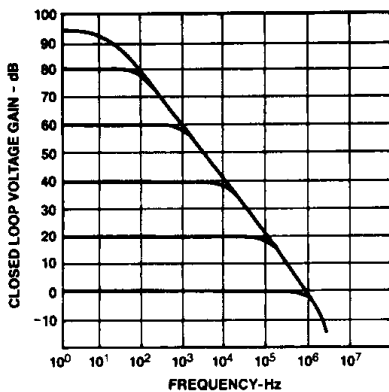

PC02471F

Open Loop vs Frequency Response

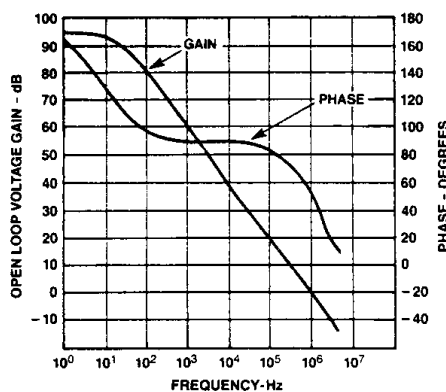

PC02480F

Output Voltage vs Frequency

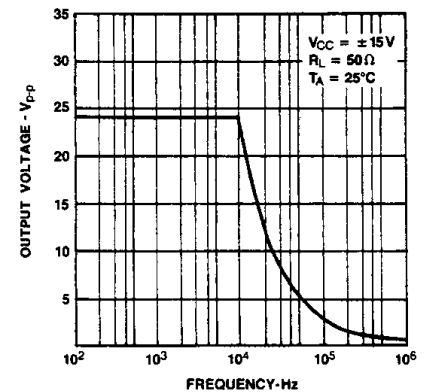

PC02491F

Typical Performance Curves (Cont.)

Output Voltage vs Load Resistance

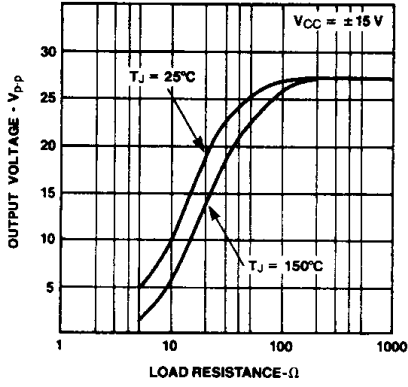

PC02501F

Voltage Follower Large Signal Pulse Response

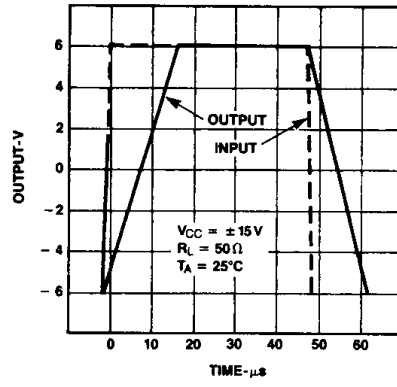

PC02510F

Voltage Follower Transient Response

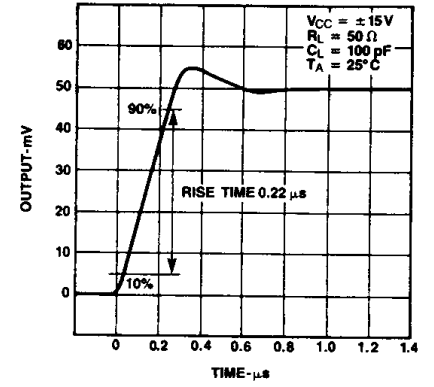

PC02520F

Total Harmonic Distortion vs Frequency

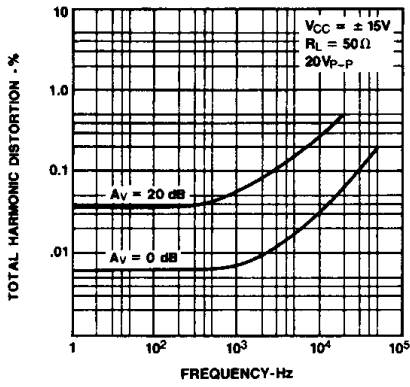

PC02531F

Total Harmonic Distortion vs Power Output

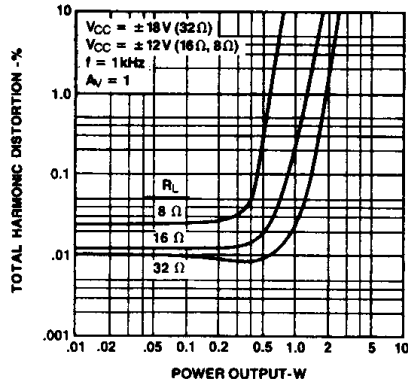

PC02541F

Input Noise Voltage vs Frequency

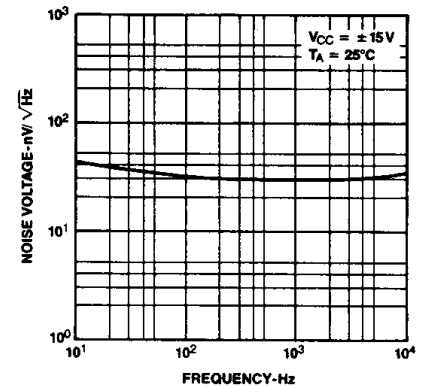

PC02550F

Noise Current vs Frequency

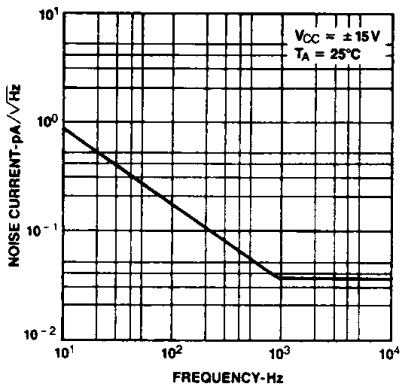

PC02561F

Short Circuit Current vs Junction Temperature

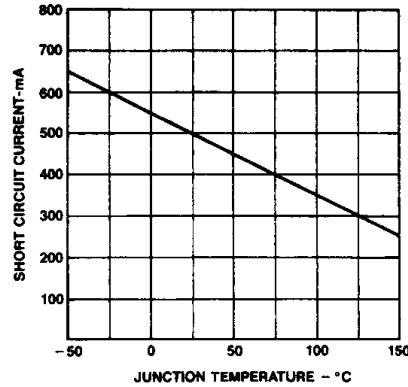

PC02571F

Peak Output Current vs Output Voltage

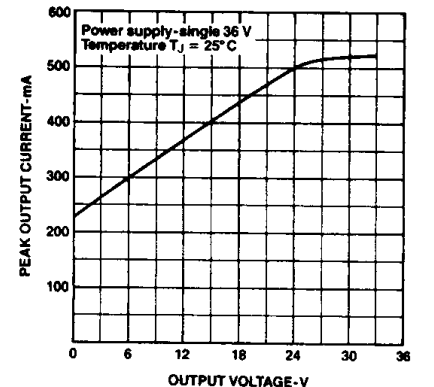

PC02580F

Offset Null Circuit

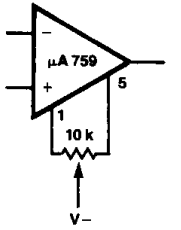

CR01091F

Paralleling μ A759 Power Op Amps

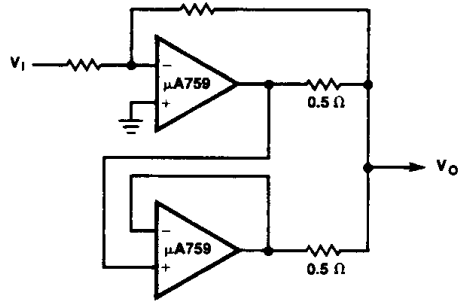

CR01101F

Audio Applications

Low Cost Phono Amplifier

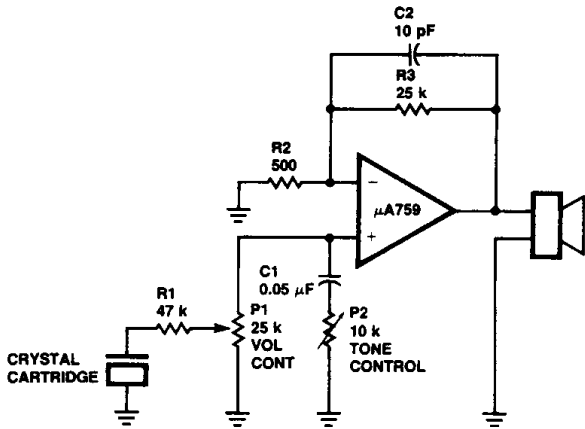

AF00231F

Speaker Impedance (ohms)	Output Power (watts)	Min Supply (volts)	V_{Op-p} (volts)
4	.18	9	2.4
8	.36	12	4.8
16	.72	15	9.6
32	1.44	25	19.2

Headphone Amplifier

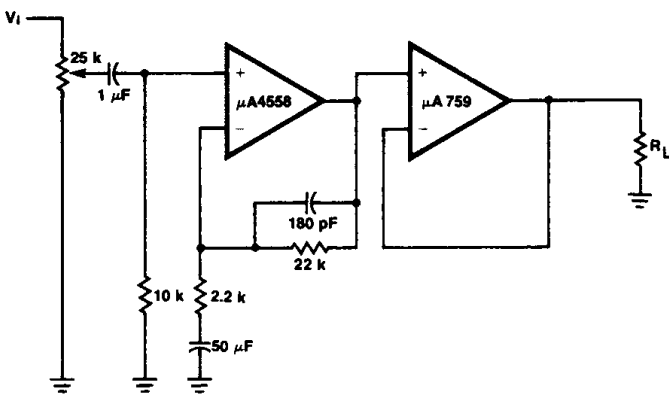

AF00241F

Note

1. All resistor values in ohms.

Bi-Directional Intercom System Using the μA759 Power Op Amp

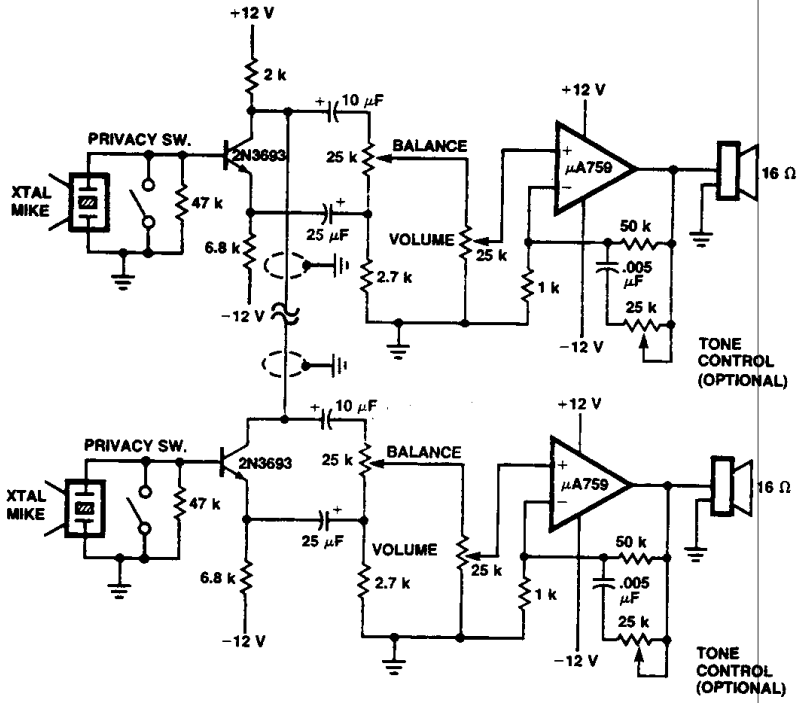

Features

- Circuit Simplicity
- 1 Watt of Audio Output
- Duplex operation with only one two-wire cable as interconnect.

Note

- All resistor values in ohms.

High Slew Rate Power OP Amp/Audio Amp

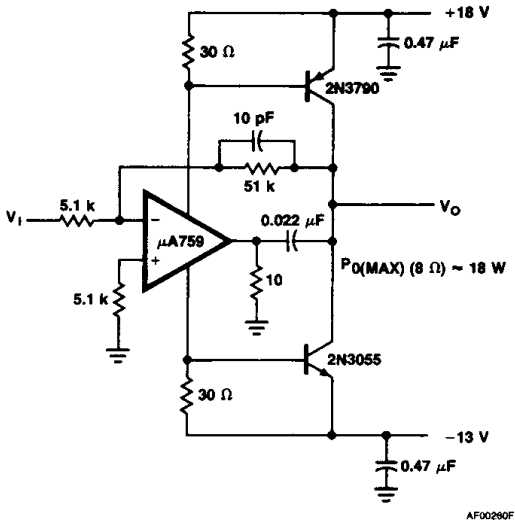

AF00260F

Features

- High Slew Rate 9 V/μs
- High 3 dB Power Bandwidth 85 kHz
- 18 Watts Output Power Into an 8 Ω Load.
- Low Distortion — .2%, 10 VRMS, 1 kHz Into 8 Ω

Design Consideration

$A_v \geq 10$

Servo Applications

DC Servo Amplifiers

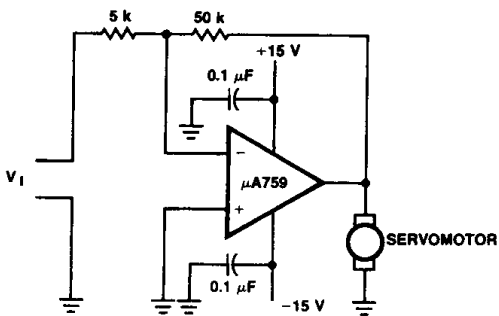

AF00260F

Features

- Circuit Simplicity
- One Chip Means Excellent Reliability

Design Considerations

$I_O \leq 325 \text{ mA}$

Note

- All resistor values in ohms.

AG Servo Amplifier – Bridge Type

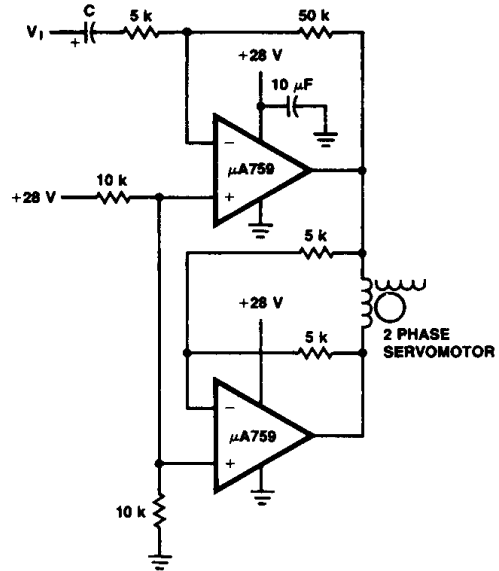

AF00270F

Features

- Gain of 10
- Use of μA759 Means Simple Inexpensive Circuit

Design Considerations

325 mA Max Output Current

Regulator Applications

Adjustable Dual Tracking Regulator

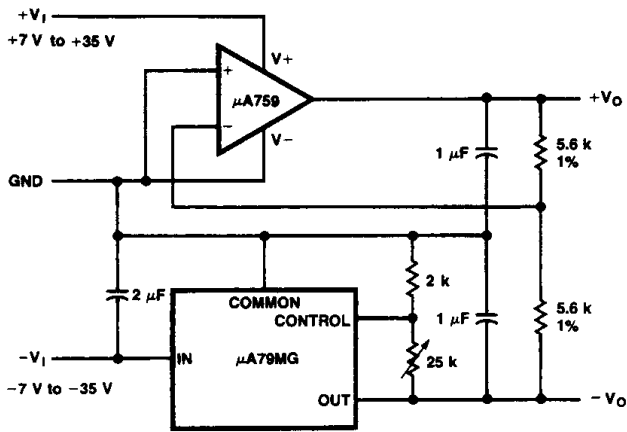

AF00281F

Features

Wide Output Voltage Range (± 2.2 to $\pm 30\text{ V}$)

Excellent Load Regulation $\Delta V_O < \pm 5\text{ mV}$ for

$\Delta I_O = \pm 0.2\text{ A}$

Excellent Line Regulation $\Delta V_O < \pm 2\text{ mV}$ for $\Delta V_I = 10\text{ V}$

Note

1. All resistor values in ohms.

Regulator Applications (Cont.)

10 Amp - 12 Volt Regulator

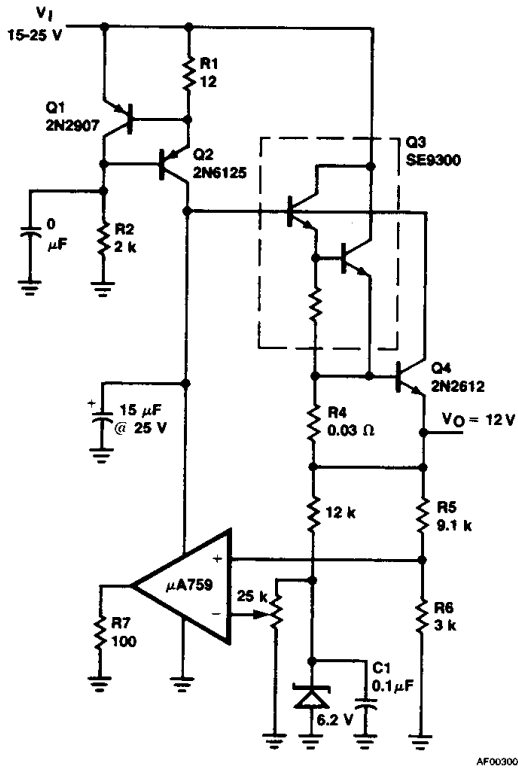

Features

- Excellent Load and Line Regulation
- Excellent Temperature Coefficient-Depends Largely on Tempo of the Reference Zener

Note

1. All resistor values in ohms.