

Features

2 Meg x 8 bit CMOS Static

Random Access Memory

- Access Times 70 thru 100ns
- Data Retention Function (EDI8F82045LP)
- TTL Compatible Inputs and Outputs
- Fully Static, No Clocks

High Density Packaging

- 36 Pin DIP, No. 177

Single +5V ($\pm 10\%$) Supply Operation

2 Megabits x 8 Static RAM CMOS, Module

The EDI8F82045C is a 16 megabit CMOS Static RAM based on four 512Kx8 Static RAMs mounted on a multi-layered epoxy laminate (FR4) substrate.

A low power version with data retention (EDI8F82045LP) is also available.

All inputs and outputs are TTL compatible and operate from a single 5V supply.

Fully asynchronous, the EDI8F82045C requires no clocks or refreshing for operation.

Pin Configurations and Block Diagram

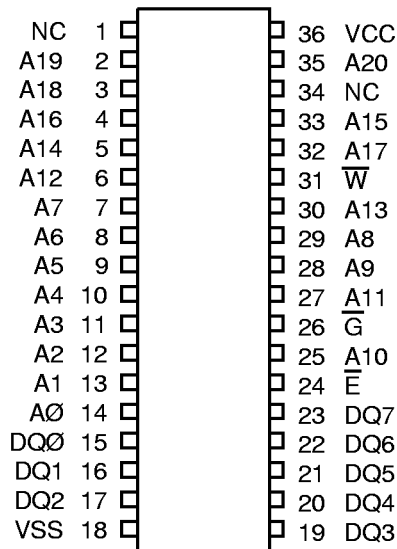

Pin Names

A0-A20	Address Inputs
\bar{E}	Chip Enable
\bar{W}	Write Enable
\bar{G}	Output Enable
DQ0-DQ7	Common Data Input/Output
VCC	Power (+5V $\pm 10\%$)
VSS	Ground
NC	No Connection

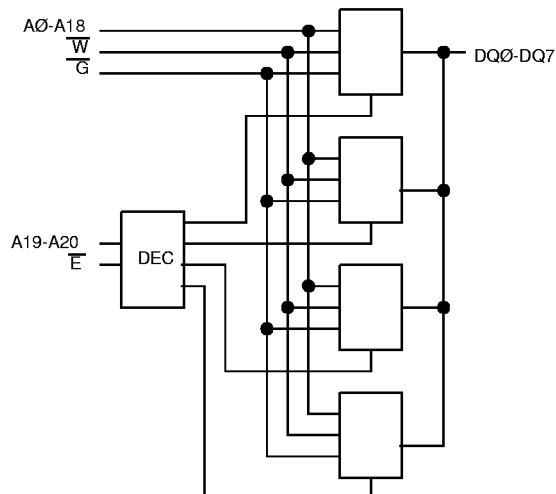

Electronic Designs Incorporated

• One Research Drive • Westborough, MA 01581 USA • 508-366-5151 • FAX 508-836-4850 •
Electronic Designs Europe Ltd. • Shelley House, The Avenue • Lightwater, Surrey GU18 5RF
 United Kingdom • 01276 472637 • FAX: 01276 473748



Absolute Maximum Ratings*

Voltage on any pin relative to VSS	-0.5V to 7.0V
Operating Temperature TA (Ambient)	
Commercial	0°C to +70°C
Industrial	-40°C to +85°C
Storage Temperature	-55°C to +125°C
Power Dissipation	1 Watt
Output Current	20 mA

*Stress greater than those listed under "Absolute Maximum Ratings" may cause permanent damage to the device. This is a stress rating only and functional operation of the device at these or any other conditions greater than those indicated in the operational sections of this specification is not implied. Exposure to absolute maximum rating conditions for extended periods may affect reliability.

Recommended DC Operating Conditions

Parameter	Sym	Min	Typ	Max	Units
Supply Voltage	VCC	4.5	5.0	5.5	V
Supply Voltage	VSS	0	0	0	V
Input High Voltage	VIH	2.2	--	6.0	V
Input Low Voltage	VIL	-0.3	--	0.8	V

AC Test Conditions

Input Pulse Levels	VSS to 3.0V
Input Rise and Fall Times	5ns
Input and Output Timing Levels	1.5V
Output Load	1TTL, CL = 100pF

(note: For TEHQZ, TGHQZ and TWLQZ, CL = 5pF)

DC Electrical Characteristics

Parameter	Sym	Conditions	Min	Typ*	Max	Units
Operating Power	ICC1	$\bar{W}, \bar{E} = VIL, I/O = 0mA,$ Min Cycle	--		150	mA
Standby (TTL) Power	ICC2	$\bar{E} \geq VIH, VIN \leq VIL$ $VIN \geq VIH$	--		55	mA
Full Standby Power	ICC3	$\bar{E} \geq VCC - 0.2V$ $VIN \geq VCC - 0.2V$ or $VIN \leq 0.2V$	C LP	--	2 3 450 600	mA μA
Input Leakage Current	ILI	$VIN = 0V$ to VCC	-10	--	10	μA
Output Leakage Current	ILO	$V I/O = 0V$ to VCC	-10	--	10	μA
Output High Voltage	VOH	$IOH = -1.0mA$	2.4	--	--	V
Output Low Voltage	VOL	$IOL = 2.1mA$	--	--	0.4	V

*Typical: TA = 25°C, VCC = 5.0V

Truth Table

\bar{G}	\bar{E}	\bar{W}	Mode	Output	Power
X	H	X	Standby	High Z	ICC2, ICC3
H	L	H	Output Deselect	High Z	ICC1
L	L	H	Read	DOUT	ICC1
X	L	L	Write	DIN	ICC1

Capacitance

(f=1.0MHz, VIN=VCC or VSS)

Parameter	Sym	Max	Unit
Address Lines	CI	30	pF
Data Lines	CD/Q	43	pF
Chip Enable Line	CC	10	pF
Write and Output Enable Lines	CW	32	pF

These parameters are sampled, not 100% tested.

AC Characteristics Read Cycle

Parameter	Symbol		70ns		85ns		100ns		Units
	JEDEC	Alt.	Min	Max	Min	Max	Min	Max	
Read Cycle Time	TAVAV	TRC	70		85		100		ns
Address Access Time	TAVQV	TAA		70		85		100	ns
Chip Enable Access Time	TELQV	TACS		70		85		100	ns
Chip Enable to Output in Low Z (1)	TELQX	TCLZ	5		5		5		ns
Chip Disable to Output in High Z (1)	TEHQZ	TCHZ		30		35		40	ns
Output Hold from Address Change	TAVQX	TOH	5		5		5		ns
Output Enable to Output Valid	TGLQV	TOE		40		45		50	ns
Output Enable to Output in Low Z (1)	TGLQX	TOLZ	5		5		5		ns
Output Disable to Output in High Z(1)	TGHQZ	TOHZ		30		35		40	ns

NOTE 1: Parameter guaranteed, but not tested.

Read Cycle 1 - W High, \bar{G} , \bar{E} Low

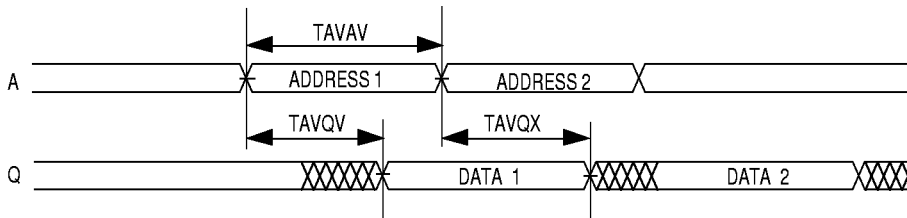

Read Cycle 2 - W High

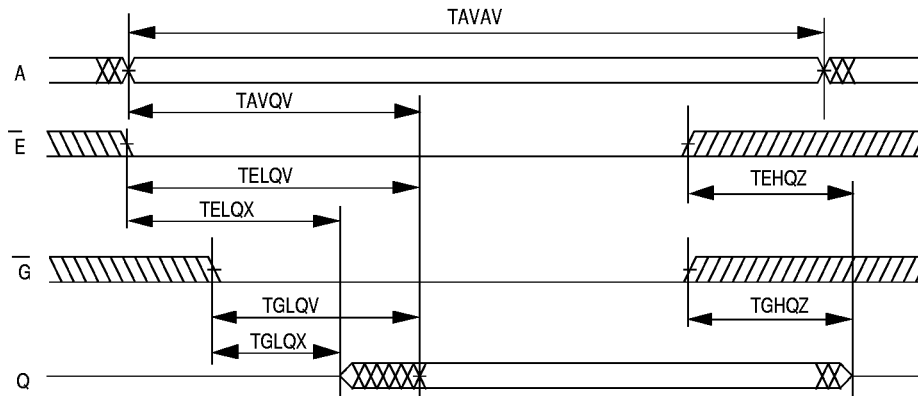

AC Characteristics Write Cycle

Write Cycle	Symbol	70ns	85ns	100ns	Units				
Parameter	JEDEC	Alt.	Min	Max	Min	Max	Min	Max	Units
Write Cycle Time	TAVAV	TWC	70		85		100		ns
Chip Enable to End of Write	TELWH	TCW	65		70		80		ns
	TELEH	TCW	65		70		80		ns
Address Setup Time	TAVWL	TAS	0		0		0		ns
	TAVEL	TAS	0		0		0		ns
Address Valid to End of Write	TAVWH	TAW	65		70		80		ns
	TAVEH	TAW	65		70		80		ns
Write Pulse Width	TWLWH	TWP	65		70		80		ns
	TWLEH	TWP	65		70		80		ns
Write Recovery Time	TWHAX	TWR	5		5		5		ns
	TEHAX	TWR	5		5		5		ns
Data Hold Time	TWHDX	TDH	0		0		0		ns
	TEHDX	TDH	0		0		0		ns
Write to Output in High Z (1)	TWLQZ	TWHZ	0	30	0	35	0	40	ns
Data to Write Time	TDVWH	TDW	30		35		40		ns
	TDVEH	TDW	30		35		40		ns
Output Active from End of Write (1)	TWHQX	TWLZ	5		5		5		ns

Note 1: Parameter guaranteed, but not tested.

Write Cycle 1 - \bar{W} Controlled

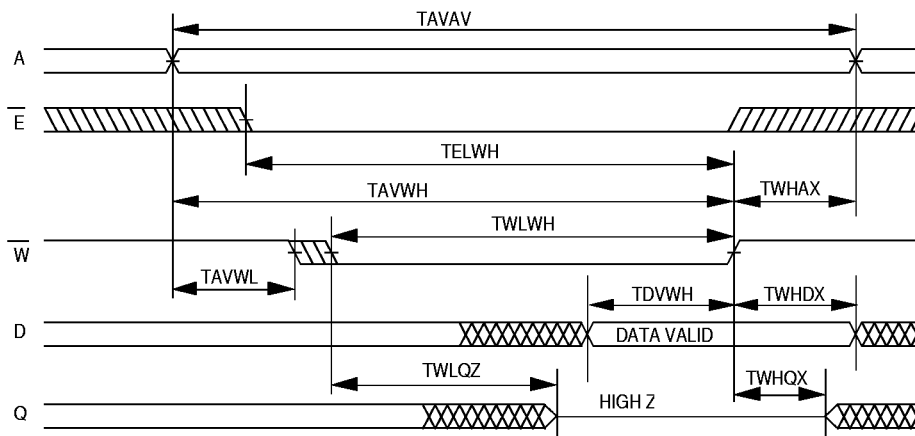

Write Cycle 2 - \bar{E} Controlled

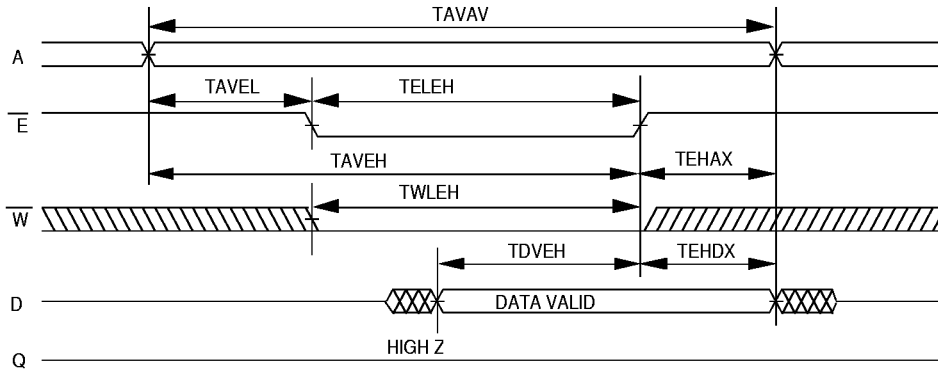

Data Retention Characteristics

LP Version Only

Characteristic	Sym	Test Conditions	VDD	Min	Typ	Max		Unit
						70°C	85°C	
Data Retention Voltage	VDD	$\bar{E} \geq VDD - 0.2V$ $V_{IN} \geq VDD - 0.2V$ or $V_{IN} \leq 0.2V$		2	--	--	--	V
Data Retention Quiescent Current	ICCDR		2V	--	200	260	μA	
			3V	--	320	420	μA	
Chip Disable to Data Retention Time	TCDR(1)			0	--	--	--	ns
Operation Recovery Time	TR(1)		TAVAV*	--	--	--	ns	

Note 1: Parameter guaranteed, but not tested.
* Read Cycle Time

Data Retention - \bar{E} Controlled

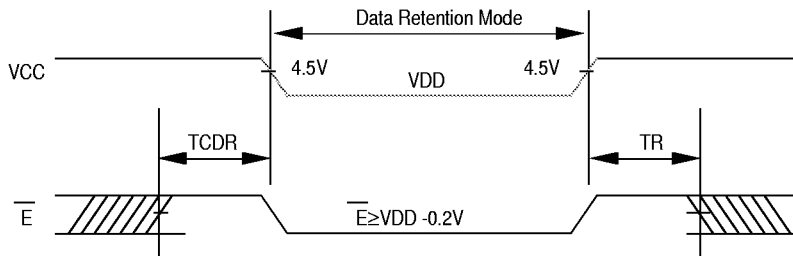



Ordering Information

Standard Power	Low Power with Data Retention	Speed (ns)	Package No.
ED18F82045C70B6C	ED18F82045LP70B6C	70	177
ED18F82045C85B6C	ED18F82045LP85B6C	85	177
ED18F82045C100B6C	ED18F82045LP100B6C	100	177

To order an Industrial grade product substitute the letter C in the Suffix with the letter I, eg. ED18F82045C70B6C becomes EDI8F82045C70B6I.

Package Description

Package No. 177
36 Pin Dual-in-line Package

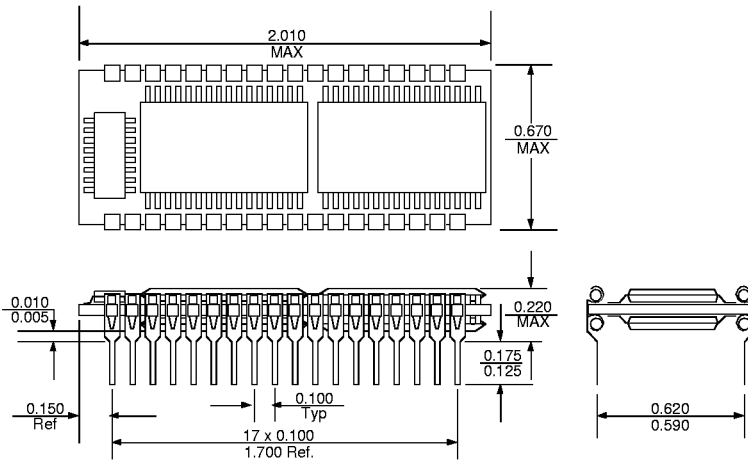

Electronic Designs Incorporated

• One Research Drive • Westborough, MA 01581USA • 508-366-5151 • FAX 508-836-4850 •
Electronic Designs Europe Ltd. • Shelley House, The Avenue • Lightwater, Surrey GU18 5RF
 United Kingdom • 01276 472637 • FAX: 01276 473748

Electronic Designs Inc. reserves the right to change specifications without notice. CAGE No. 66301