

Product Specification

# SPECIFICATION FOR APPROVAL



Alpha Point Ltd.  
Vernissakatu 8A  
01300 Vantaa, Finland  
<http://www.alpha.fi>

Tel.: +358-9-34 64 34 1  
Fax: +358-9-34 64 34 2

- ( ● ) Preliminary Specification  
(   ) Final Specification

Title	20.1" VGA TFT LCD
-------	-------------------

BUYER	-
MODEL	-

SUPPLIER	LG.Philips LCD Co., Ltd.
*MODEL	LC201V02
SUFFIX	A3

\*When you obtain standard approval,  
please use the above model name without suffix

APPROVED BY	SIGNATURE DATE
/	_____
/	_____
/	_____

Please return 1 copy for your confirmation with  
your signature and comments.

APPROVED BY	SIGNATURE DATE
S.W Lee / G.Manager	_____
<b>REVIEWED BY</b>	
J.T Kim / Manager	_____
<b>PREPARED BY</b>	
J.K Choi / Engineer	_____

**MNT/TV Products Engineering Dept.**  
**LG. Philips LCD Co., Ltd**

Product Specification

Contents

No	ITEM	Page
	COVER	1
	CONTENTS	2
	RECORD OF REVISIONS	3
1	GENERAL DESCRIPTION	4
2	ABSOLUTE MAXIMUM RATINGS	5
3	ELECTRICAL SPECIFICATIONS	6
3-1	ELECTRICAL CHARACTERISTICS	6
3-2	INTERFACE CONNECTIONS	9
3-3	SIGNAL TIMING SPECIFICATIONS	11
3-4	SIGNAL TIMING WAVEFORMS	12
3-5	COLOR INPUT DATA REFERENCE	13
3-6	POWER SEQUENCE	14
4	OPTICAL SPECIFICATIONS	15
5	MECHANICAL CHARACTERISTICS	19
6	RELIABILITY	22
7	INTERNATIONAL STANDARDS	23
7-1	SAFETY	23
7-2	EMC	24
8	PACKING	24
8-1	DESIGNATION OF LOT MARK	24
8-2	PACKING FORM	24
9	PRECAUTIONS	25



Product Specification

### 1. General Description

LC201V02 is a Color Active Matrix Liquid Crystal Display with an integral Cold Cathode Fluorescent Lamp(CCFL) backlight system. The matrix employs a-Si Thin Film Transistor as the active element. It is a transmissive type display operating in the normally black mode. It has a 20.1 inch diagonally measured active display area with VGA resolution (480 vertical by 640 horizontal pixel array) Each pixel is divided into Red, Green and Blue sub-pixels or dots which are arranged in vertical stripes. Gray scale or the brightness of the sub-pixel color is determined with a 8-bit gray scale signal for each dot, thus, a palette of more than 16,777,216 colors.

It has been designed to apply the 8Bit parallel CMOS interface.

It is intended to support LCD TV, PCTV where high brightness, wide viewing angle, high color saturation, and high color are important.

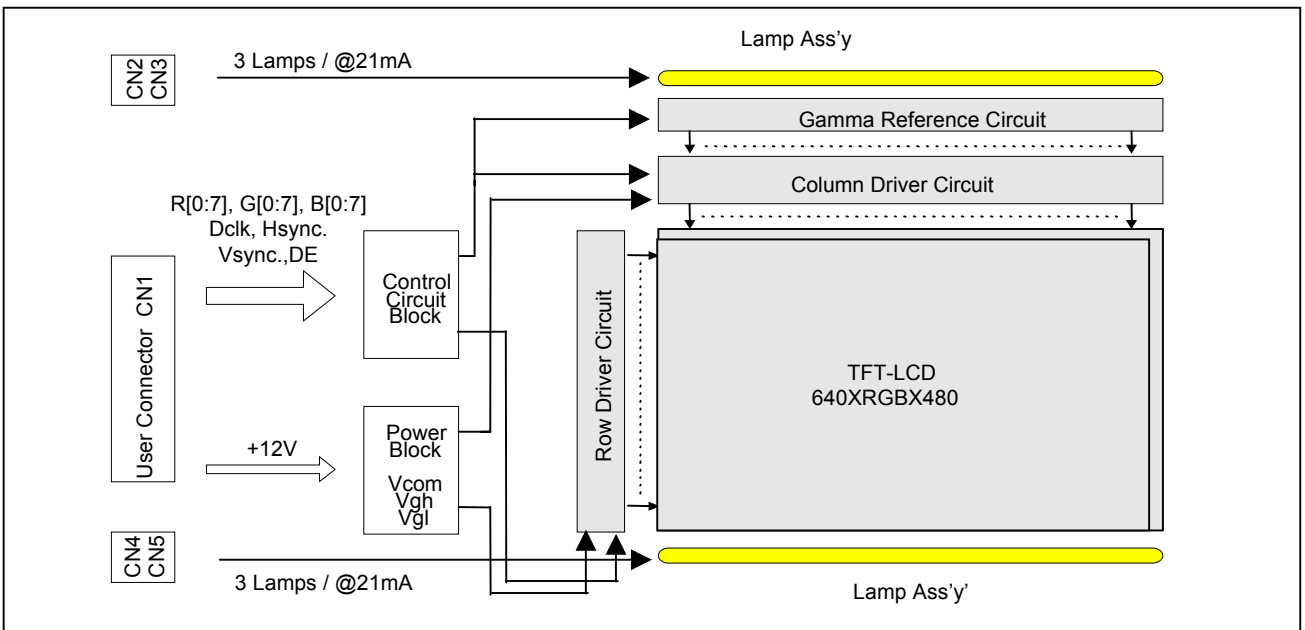

### General Features

Active Screen Size	20.1 inches(510.54mm) diagonal
Outline Dimension	432(H) x 331.5(V) x 25.0(D) mm(Typ.)
Pixel Pitch	0.6375mm x 0.6375mm
Pixel Format	640 horiz. By 480 vert. Pixels RGB stripe arrangement
Color Depth	8-bits,16,777,216 colors
Luminance, White	450 cd/m <sup>2</sup> (Center 1 point (Typ.))
Viewing Angle (CR>10)	Viewing Angle Free [R/L 170(Typ.), U/D 170(Typ.)]
Power Consumption	TBD
Weight	3,200 g (Typ.)
Display Operating Mode	Transmissive mode, normally black
Surface Treatment	Hard coating(3H) & Anti-glare treatment of the front polarizer

Product Specification

## 2. Absolute Maximum Ratings

The following are maximum values which, if exceeded, may cause faulty operation or damage to the unit.

**Table 1. ABSOLUTE MAXIMUM RATINGS**

Parameter	Symbol	Values		Units	Notes
		Min	Max		
Power Input Voltage	VLCD	-0.3	+14.0	Vdc	
Operating Temperature	TOP	0	50	°C	1
Storage Temperature	HST	-20	60	°C	1
Operating Ambient Humidity	HOP	10	90	%RH	1
Storage Humidity	HST	10	90	%RH	1

Note : 1. Temperature and relative humidity range are shown in the figure below.  
Wet bulb temperature should be 39 °C Max, and no condensation of water.

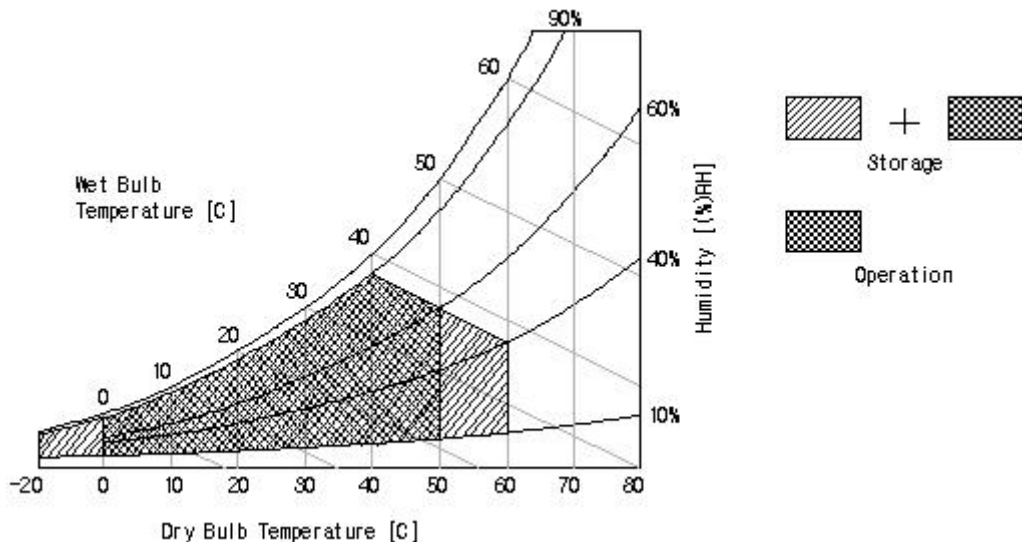



## Product Specification

**Table 2\_2. ELECTRICAL CHARACTERISTICS**

Parameter	Symbol	Values			Unit	Notes
		Min	Typ	Max		
LAMP :						
Operating Voltage	V <sub>BL</sub>	700(7.5mA)	720(7mA)	825(3mA)	V <sub>RMS</sub>	1, 2
Operating Current	I <sub>BL</sub>	3.0	7.0	7.5	mA <sub>RMS</sub>	1
Established Starting Voltage	V <sub>S</sub>					1, 3
	at 25 °C			1,100	V <sub>RMS</sub>	
	at 0 °C			1,430	V <sub>RMS</sub>	
Operating Frequency	f <sub>BL</sub>	40	50	60	kHz	4
Discharge Stabilization Time	T <sub>S</sub>			3	Min	1, 5
Power Consumption	P <sub>BL</sub>		30.24	33.27	Watt	6
Life Time		50,000			Hrs	1, 7

Note : The design of the inverter must have specifications for the lamp in LCD Assembly.

The performance of the Lamp in LCM, for example life time or brightness, is extremely influenced by the characteristics of the DC-AC inverter. So all the parameters of an inverter should be carefully designed so as not to produce too much leakage current from high-voltage output of the inverter.

When you design or order the inverter, please make sure unwanted lighting caused by the mismatch of the lamp and the inverter (no lighting, flicker, etc) never occurs. When you confirm it, the LCD-Assembly should be operated in the same condition as installed in you instrument.

※ Do not attach a conducting tape to lamp connecting wire.

If the lamp wire attach to a conducting tape, TFT-LCD Module has a low luminance and the inverter has abnormal action. Because leakage current is occurred between lamp wire and conducting tape.

- Specified values are for a single lamp.
- Operating voltage is measured at  $25 \pm 2^\circ\text{C}$ . The variance of the voltage is  $\pm 10\%$ .
- The voltage above  $V_S$  should be applied to the lamps for more than 1 second for start-up. (Inverter open voltage must be more than lamp starting voltage.)  
Otherwise, the lamps may not be turned on. The used lamp current is the lamp typical current.
- Lamp frequency may produce interface with horizontal synchronous frequency and as a result this may cause beat on the display. Therefore lamp frequency shall be as away possible from the horizontal synchronous frequency and from its harmonics in order to prevent interference.
- Let's define the brightness of the lamp after being lighted for 5 minutes as 100%.  
 $T_S$  is the time required for the brightness of the center of the lamp to be not less than 95%.
- The lamp power consumption shown above does not include loss of external inverter.  
The used lamp current is the lamp typical current. ( $P_{BL} = V_{BL} \times I_{BL} \times N_{Lamp}$  )
- The life is determined as the time at which brightness of the lamp is 50% compared to that of initial value at the typical lamp current on condition of continuous operating at  $25 \pm 2^\circ\text{C}$ .

**Product Specification**

8. The output of the inverter must have symmetrical(negative and positive) voltage waveform and symmetrical current waveform (Unsymmetrical ratio is less than 10%). Please do not use the inverter which has unsymmetrical voltage and unsymmetrical current and spike wave. Requirements for a system inverter design, which is intended to have a better display performance, a better power efficiency and a more reliable lamp, are following.

It shall help increase the lamp lifetime and reduce leakage current.

- a. The asymmetry rate of the inverter waveform should be less than 10%.
- b. The distortion rate of the waveform should be within  $\sqrt{2} \pm 10\%$ .

\* Inverter output waveform had better be more similar to ideal sine wave.

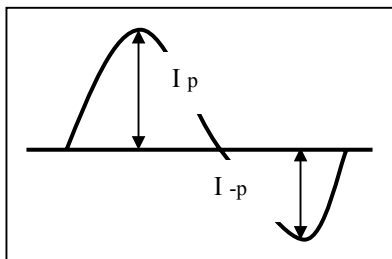

\* Asymmetry rate:

$$\frac{|I_p - I_{-p}|}{I_{rms}} \times 100\%$$

\* Distortion rate

$$I_p \text{ (or } I_{-p}) / I_{rms}$$

9. The inverter which is combined with this LCM, is highly recommended to connect coupling(ballast) condenser at the high voltage output side. When you use the inverter which has not coupling(ballast) condenser, it may cause abnormal lamp lighting because of biased mercury as time goes.
10. In case of edgy type back light with over 4 parallel lamps, input current and voltage wave form should be synchronized



Product Specification

### 3-2. Interface Connections

- LCD Connector(CN1):DF9B-41P-1V (Manufactured by Hirose) or Equivalent
- Mating Connector : DF9B-41S-1V (Manufactured by Hirose) or Equivalent

**Table 3. MODULE CONNECTOR(CN1) PIN CONFIGURATION**

Pin No	Symbol	Description	Pin No	Symbol	Description
1	RBF	NC 1)	21	G4	
2	DCLK	Dot Clock	22	GND	System Ground
3	GND	System Ground 2)	23	G5	
4	Hsync	Horizontal Sync	24	G6	
5	Vsync	Vertical Sync	25	G7	Green Data(MSB)
6	GND		26	B0	Blue Data(LSB)
7	R0	Red Data(LSB)	27	GND	System Ground
8	R1		28	B1	
9	R2		29	B2	
10	R3		30	B3	
11	R4		31	B4	
12	GND	System Ground	32	GND	System Ground
13	R5		33	B5	
14	R6		34	B6	
15	R7	Red Data(MSB)	35	B7	Blue Data(MSB)
16	G0	Green Data(LSB)	36	GND	System Ground
17	GND	System Ground	37	DE	Data Enable
18	G1		38	GND	System Ground
19	G2		39	V <sub>LCD</sub>	Power input(+12.0V)
20	G3		40	V <sub>LCD</sub>	Power input(+12.0V)
			41	V <sub>LCD</sub>	Power input(+12.0V)

**Rear view of LCM**

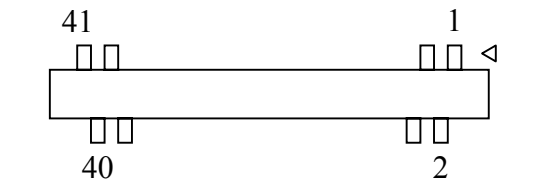

- Note:
1. NC: No Connection.
  2. All GND(ground) pins should be connected together and to Vss which should also be connected to the LCD's metal frame.
  3. All V<sub>LCD</sub> (power input) pins should be connected together.

Product Specification

**Table 4. BACKLIGHT CONNECTOR PIN CONFIGURATION(CN2,CN3,CN4,CN5)**

The backlight interface connector is a model BHSR-02VS-1(CN3/CN4) and BHR-05VS-1(CN2/CN5) manufactured by JST. The mating connector part number are SM02B-BHSS-1-TB(2pin), SM04(9-E2)B-BHS-1-TB(5pin) or equivalent. The pin configuration for the connector is shown in the table below.

No	Pin	Symbol	Description	Notes
CN2	1	HV	Power supply for lamp 1(High voltage side) – Gray	1
	2	HV	Power supply for lamp 2(High voltage side) – Sky Blue	1
	3	NC	NC	
	4	LV	Power supply for lamp 1(Low voltage side) – Black	2
	5	LV	Power supply for lamp 2(Low voltage side) – Dark Blue	2
CN3	1	HV	Power supply for lamp 3(High voltage side) – White	1
	2	LV	Power supply for lamp 3(Low voltage side) – White	2
CN4	1	HV	Power supply for lamp 4(High voltage side) – White	1
	2	LV	Power supply for lamp 4(Low voltage side) – White	2
CN5	1	HV	Power supply for lamp 6(High voltage side) – Gray	1
	2	HV	Power supply for lamp 5(High voltage side) – Sky Blue	1
	3	NC	NC	
	4	LV	Power supply for lamp 6(Low voltage side) – Black	2
	5	LV	Power supply for lamp 5(Low voltage side) – Dark Blue	2

- Notes: 1. The high voltage power terminal is colored white,sky blue,gray.  
2. The low voltage pin color is white,dark blue,black .

<BACKLIGHT CONNECTOR DIAGRAM>

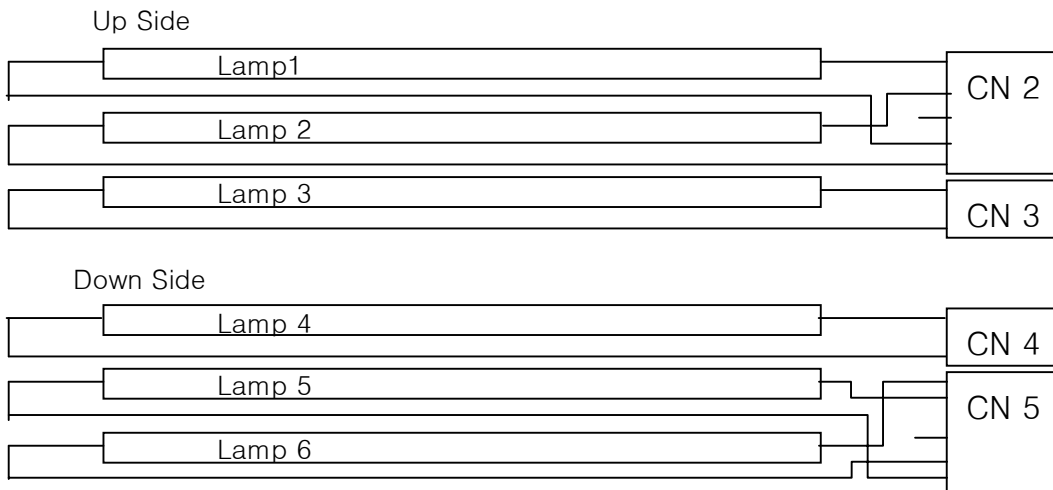

Product Specification

### 3-3. Signal Timing Specifications

This is the signal timing required at the input of the User connector. All of the interface signal timing should be satisfied with the following specifications for it's proper operation.

**Table 5. Timing Table**

ITEM	Symbol		Min	Typ	Max	Unit	Note
DCLK	Period	tCLK	33.3	40	55	ns	
	Frequency	-	18	25	30	MHz	
	High Duration	twCH	10	-	-	ns	
	Low Duration	twCL	10	-	-	ns	
Hsync	Period	tHP	790	800	850	tCLK	
	Width	tWH	16	96	-	tCLK	
Vsync	Period	tVP	490	525	560	tHP	PAL: 47~53Hz
	Frequency	fV	47	60	63	Hz	NTSC: 57~63Hz
	Width	twV	2	3	-	tHP	
DE (Data Enable)	Horizontal Valid	tHV	640	640	640	tCLK	
	Horizontal Back Porch	tHBP	16	48	-		
	Horizontal Front Porch	tHFP	16	16	-		
	Horizontal Blank	-	150	-	tHP-THV		
	Vertical Valid	tVV	480	480	480	tHP	
	Vertical Back Porch	tVBP	3	33	-		
	Vertical Front Porch	tVFP	2	9	-		
	Vertical Blank	-	10	-	tVP-tVV		
	DE SET UP TIME	tSI	3	-	-	ns	
	DE HOLD TIME	tHI	3	-	-		
Input Voltage	High	VrH	0.7Vcc	-	-	V	
	Low	VrL	-	-	0.3Vcc		
Data	Set-up time	tSD	3			ns	For DCLK
	Hold time	tHD	3				

**Note:**

Hsync period and Hsync width-active should be even number times of tCLK. If the value is odd number times of tCLK, display control signal can be asynchronous. In order to operate this LCM a Hsync., Vsync and DE (Data Enable) signals should be used.

1. The performance of the electro-optical characteristics are may be influenced by variance of the vertical refresh rates.
2. Vsync, Hsync should be keep the above specification.
3. Hsync Period, Hsync. Width and Horizontal Back Porch should be any times of a character number (8).

Product Specification

### 3-4. Signal Timing Waveforms

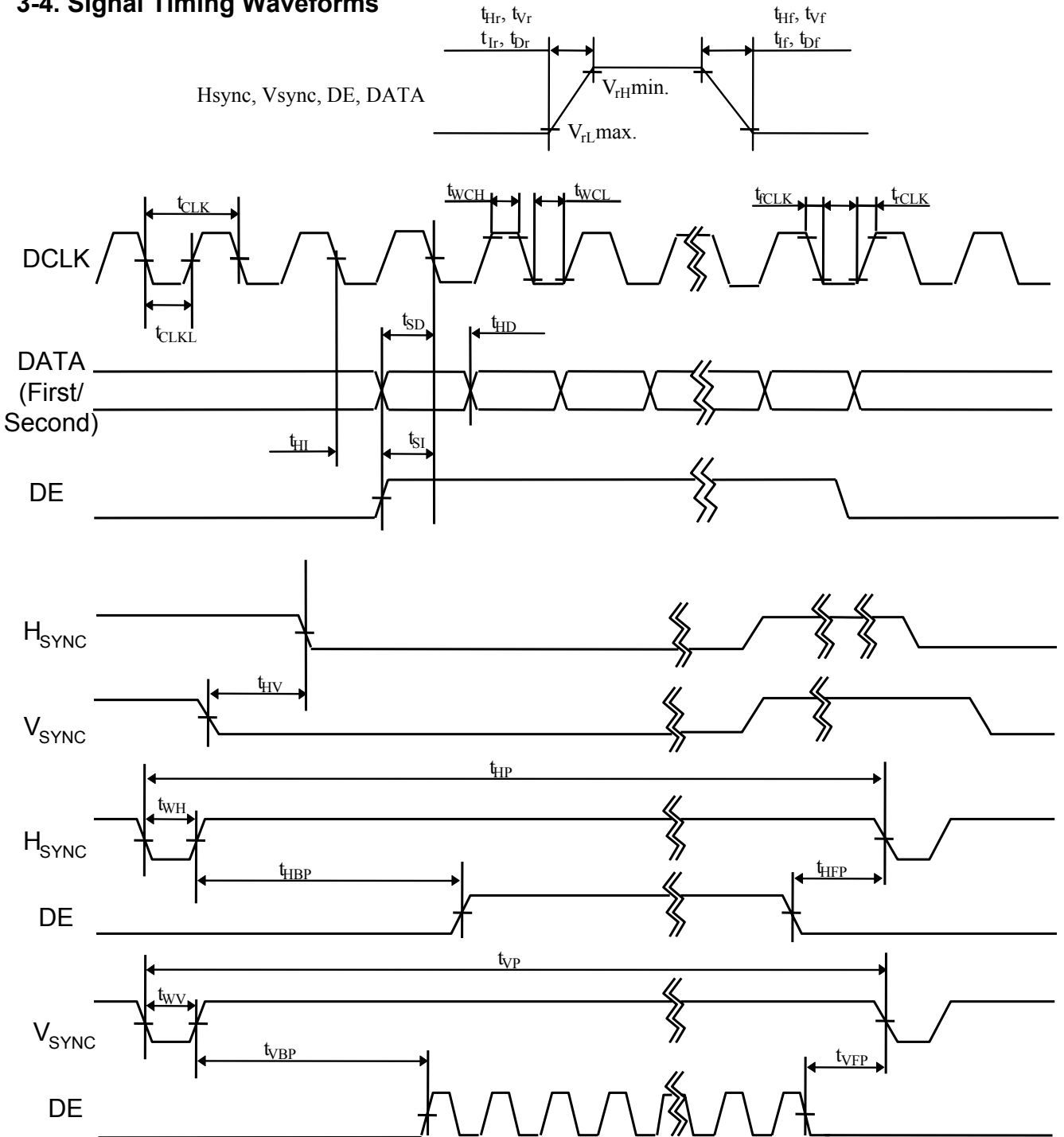

Product Specification

### 3-5. Color Input Data Reference

The Brightness of each primary color(red,green,blue) is based on the 8-bit gray scale data input for the color; the higher the binary input, the brighter the color. The table below provides a reference for color versus data input.

**Table 8. COLOR DATA REFERENCE**

Color		Input Color Data																							
		RED								GREEN								BLUE							
		MSB				LSB				MSB				LSB				MSB				LSB			
		R7	R6	R5	R4	R3	R2	R1	R0	G7	G6	G5	G4	G3	G2	G1	G0	B7	B6	B5	B4	B3	B2	B1	B0
Basic Color	Black	0	0	0	0	0	0	0	0	0	0	0	0	0	0	0	0	0	0	0	0	0	0	0	0
	Red (255)	1	1	1	1	1	1	1	1	0	0	0	0	0	0	0	0	0	0	0	0	0	0	0	0
	Green (255)	0	0	0	0	0	0	0	0	1	1	1	1	1	1	1	1	0	0	0	0	0	0	0	0
	Blue (255)	0	0	0	0	0	0	0	0	0	0	0	0	0	0	0	0	1	1	1	1	1	1	1	1
	Cyan	0	0	0	0	0	0	0	0	1	1	1	1	1	1	1	1	1	1	1	1	1	1	1	1
	Magenta	1	1	1	1	1	1	1	1	0	0	0	0	0	0	0	0	1	1	1	1	1	1	1	1
	Yellow	1	1	1	1	1	1	1	1	1	1	1	1	1	1	1	1	0	0	0	0	0	0	0	0
	White	1	1	1	1	1	1	1	1	1	1	1	1	1	1	1	1	1	1	1	1	1	1	1	1
RED	RED (000)	0	0	0	0	0	0	0	0	0	0	0	0	0	0	0	0	0	0	0	0	0	0	0	0
	RED (001)	0	0	0	0	0	0	0	1	0	0	0	0	0	0	0	0	0	0	0	0	0	0	0	0
	...	...								...								...							
	RED (254)	1	1	1	1	1	1	1	0	0	0	0	0	0	0	0	0	0	0	0	0	0	0	0	0
	RED (255)	1	1	1	1	1	1	1	1	0	0	0	0	0	0	0	0	0	0	0	0	0	0	0	0
GREEN	GREEN (000)	0	0	0	0	0	0	0	0	0	0	0	0	0	0	0	0	0	0	0	0	0	0	0	0
	GREEN (001)	0	0	0	0	0	0	0	0	0	0	0	0	0	0	0	1	0	0	0	0	0	0	0	0
	...	...								...								...							
	GREEN (254)	0	0	0	0	0	0	0	0	1	1	1	1	1	1	1	0	0	0	0	0	0	0	0	0
	GREEN (255)	0	0	0	0	0	0	0	0	1	1	1	1	1	1	1	1	0	0	0	0	0	0	0	0
BLUE	BLUE (000)	0	0	0	0	0	0	0	0	0	0	0	0	0	0	0	0	0	0	0	0	0	0	0	0
	BLUE (001)	0	0	0	0	0	0	0	0	0	0	0	0	0	0	0	0	0	0	0	0	0	0	0	1
	...	...								...								...							
	BLUE (254)	0	0	0	0	0	0	0	0	0	0	0	0	0	0	0	0	1	1	1	1	1	1	1	0
	BLUE (255)	0	0	0	0	0	0	0	0	0	0	0	0	0	0	0	0	1	1	1	1	1	1	1	1

Product Specification

### 3-6. Power Sequence

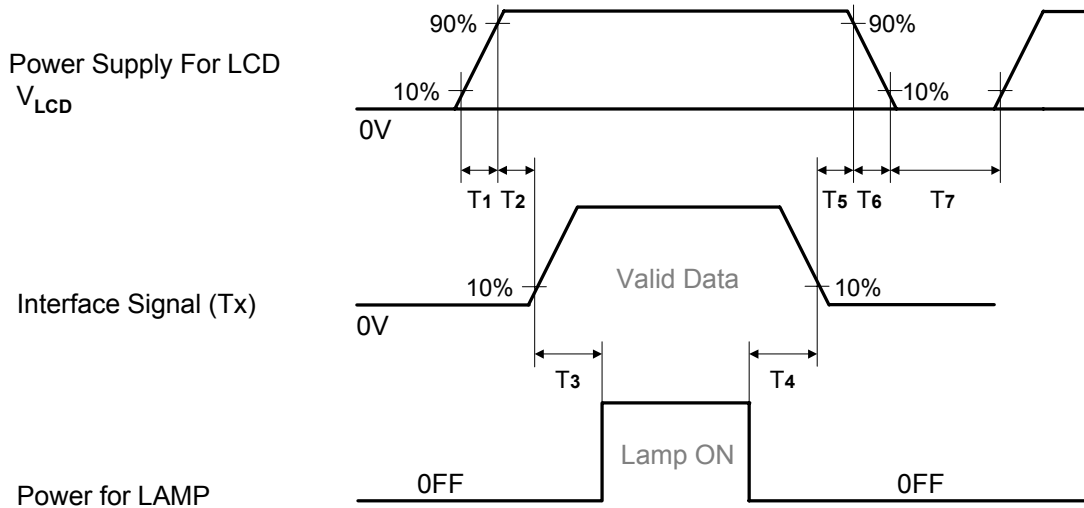

**Table 9. POWER SEQUENCE**

Parameter	Values			Units
	Min	Typ	Max	
T1	0.5	-	10	ms
T2	0.5	-	50	ms
T3	200	-	-	ms
T4	200	-	-	ms
T5	0.5	-	50	ms
T6	-	-	100	ms
T7	1	-	-	s

- Notes :
1. Please avoid floating state of interface signal at invalid period.
  2. When the interface signal is invalid, be sure to pull down the power supply for LCD  $V_{LCD}$  to 0V.
  3. Lamp power must be turn on after power supply for LCD an interface signal are valid.

Product Specification

4. Optical Specification

Optical characteristics are determined after the unit has been 'ON' and stable for approximately 30 minutes in a dark environment at 25°C. The values specified are at an approximate distance 50cm from the LCD surface at a viewing angle of  $\Phi$  and  $\theta$  equal to 0°.

FIG. 1 presents additional information concerning the measurement equipment and method.

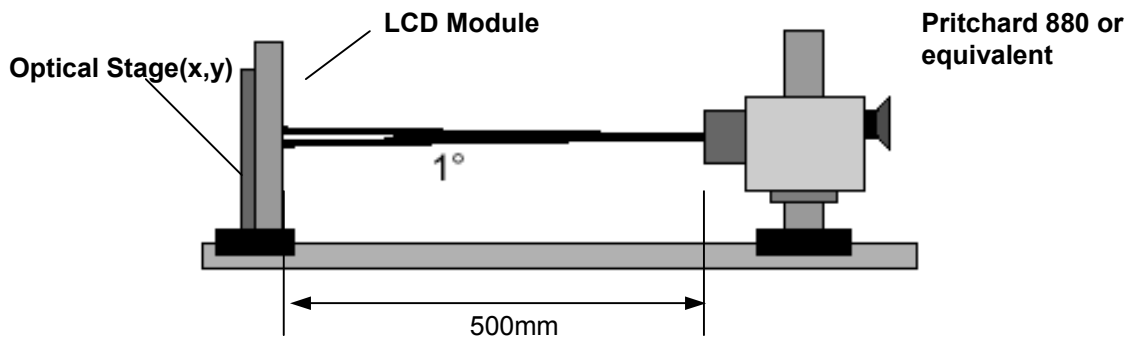

FIG. 1 Optical Characteristic Measurement Equipment and Method

Table 10. OPTICAL CHARACTERISTICS

Ta= 25°C, V<sub>LCD</sub>=12.0V, fv=60HzDclk=25MHz, I<sub>BL</sub>=7mA

Parameter	Symbol	Values			Units	Notes	
		Min	Typ	Max			
Contrast Ratio	CR	300	400	-		1	
Surface Luminance, white	L <sub>WH</sub>	380	450	-	cd/m <sup>2</sup>	2	
Luminance Variation	$\delta_{WHITE}$ 5P			1.3		3	
Response Time	Rise Time	Tr <sub>R</sub>	-	15	25	ms	4
	Decay Time	Tr <sub>D</sub>	-	15	25	ms	4
Color Coordinates [CIE1931]	RED	Rx	Typ -0.03	0.630	Typ +0.03		
		Ry		0.335			
	GREEN	Gx		0.286			
		Gy		0.575			
	BLUE	Bx		0.143			
		By		0.084			
	WHITE	Wx		0.289			
		Wy		0.304			
Viewing Angle (CR>10)							
	x axis, right( $\phi=0^\circ$ )	$\theta_r$	-	85		degree	5
	x axis, left ( $\phi=180^\circ$ )	$\theta_l$	-	85			
	y axis, up ( $\phi=90^\circ$ )	$\theta_u$	-	85			
	y axis, down ( $\phi=270^\circ$ )	$\theta_d$	-	85			
Gray Scale				-			6

Product Specification

Notes 1. Contrast Ratio(CR) is defined mathematically as :

$$\text{Contrast Ratio} = \frac{\text{Surface Luminance with all white pixels}}{\text{Surface Luminance with all black pixels}}$$

It is measured at center point(1).

2. Surface luminance is luminance value at center point (1) across the LCD surface 50cm from the surface with all pixels displaying white. For more information see FIG 2.

3. The variation in surface luminance ,  $\delta$  WHITE is defined as :

$$\delta \text{ WHITE}(5P) = \frac{\text{Maximum}(L_{on1}, L_{on2}, L_{on3}, \dots, L_{on5})}{\text{Minimum}(L_{on1}, L_{on2}, L_{on3}, \dots, L_{on5})}$$

Where  $L_{on1}$  to  $L_{on5}$  are the luminance with all pixels displaying white at 5 locations

4. Response time is the time required for the display to transition from black to white(Rise Time,  $Tr_R$ ) and from white to black(Decay Time,  $Tr_D$ ). For additional information see FIG 3.

5. Viewing angle is the angle at which the contrast ratio is greater than 10. The angles are determined for the horizontal or x axis and the vertical or y axis with respect to the z axis which is normal to the LCD surface. For more information see FIG 4.

6. Gray scale specification

Gamma Value is approximately 2.2. For more information see Table 11.

**Table 11. Gray Scale Specification**

Gray Level	Luminance [%] (Typ)
L0	TBD
L15	TBD
L31	TBD
L47	TBD
L63	TBD
L79	TBD
L95	TBD
L111	TBD
L127	TBD
L143	TBD
L159	TBD
L175	TBD
L191	TBD
L207	TBD
L223	TBD
L239	TBD
L255	TBD





Product Specification

Dimension of viewing angle range

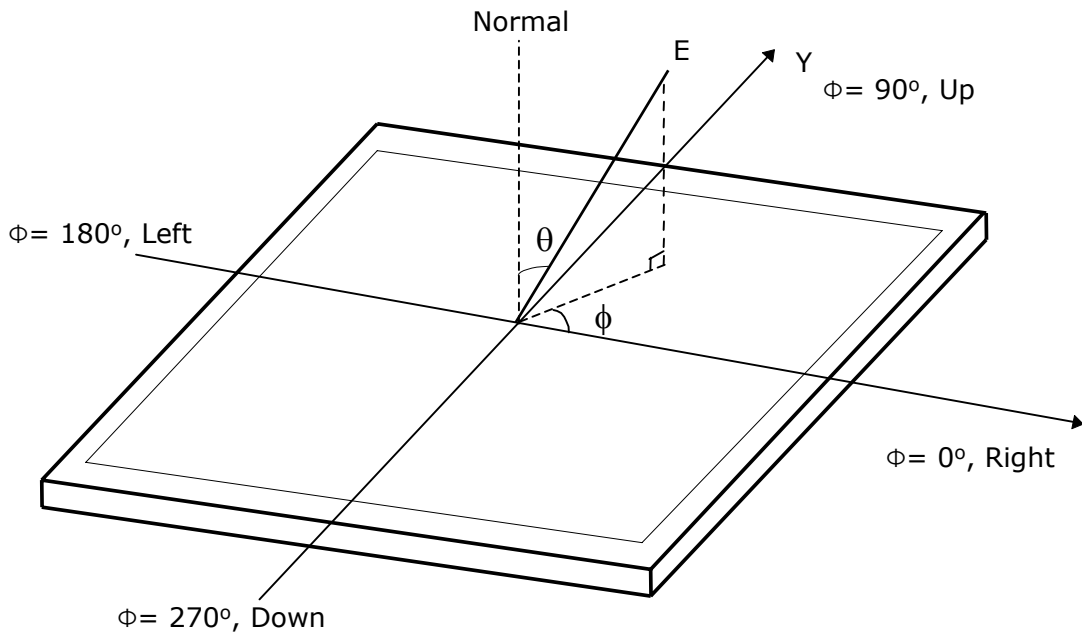

FIG. 4 Viewing angle

Product Specification

### 5. Mechanical Characteristics

The contents provide general mechanical characteristics. In addition the figures in the next page are detailed mechanical drawing of the LCD.

Outline Dimension	Horizontal	432.0mm
	Vertical	331.5mm
	Depth	25.0 mm
Bezel Area	Horizontal	413.0 mm
	Vertical	311.0mm
Active Display Area	Horizontal	408.0mm
	Vertical	306.0mm
Weight	3200g (Typ.),3360g(Max)	
Surface Treatment	Hard coating(3H) Anti-glare treatment of the front polarizer	

Notes : Please refer to a mechanic drawing in terms of tolerance at the next page.

Product Specification

<FRONT VIEW>

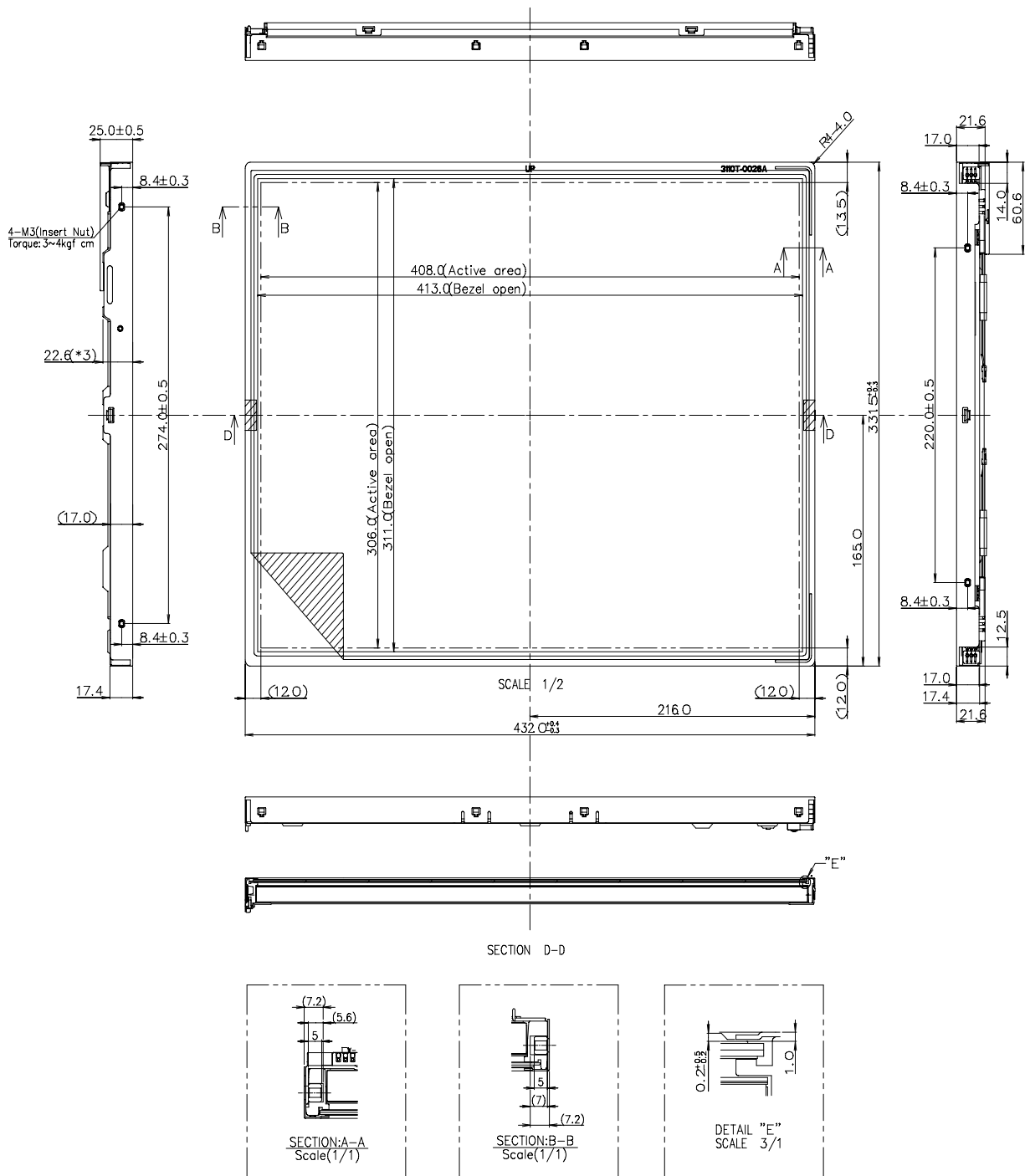

Product Specification

<REAR VIEW>

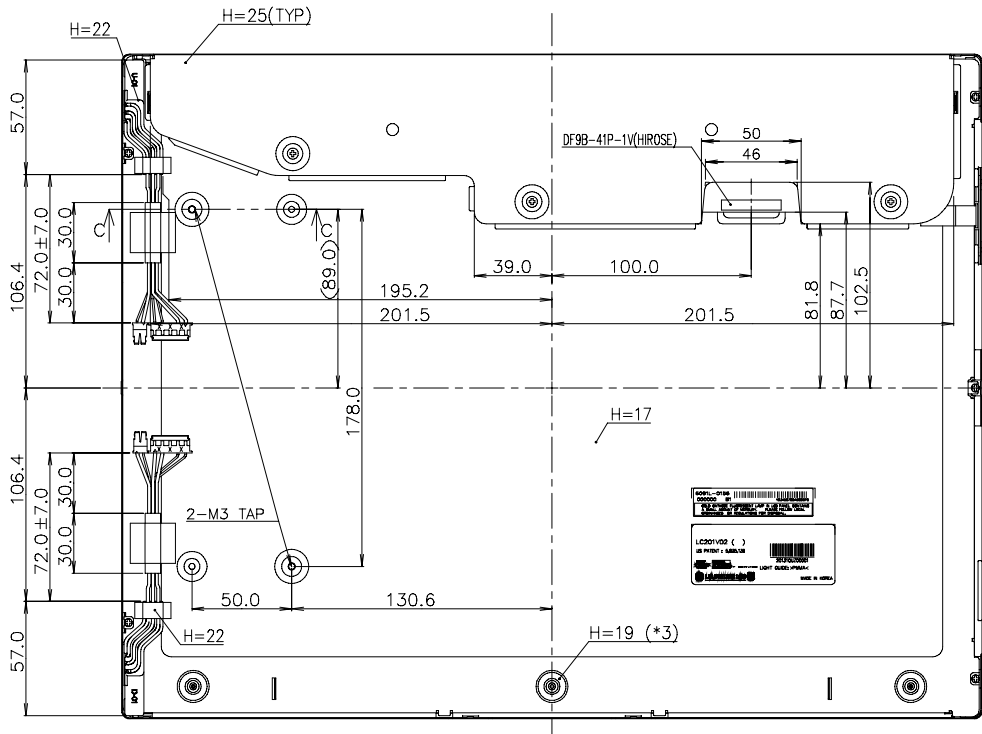

SCALE 1/2

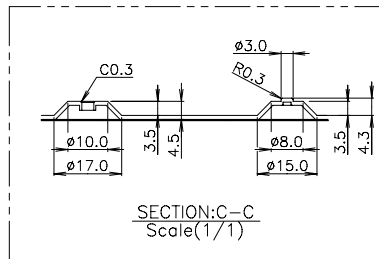

NOTES

1. Unspecified tolerances are to be  $\pm 0.5\text{mm}$ .
2. Both backlight wires and contraction tubes are excluded from outline dimensions.
3. Tilt and partial disposition tolerance of display area are as following.
  - (1) Y-Direction : IA-BI  $\leq 1.0\text{mm}$
  - (2) X-Direction : IC-DI  $\leq 1.0\text{mm}$
4. Lamp(CCFL) lot No.is marked at backlight connector.

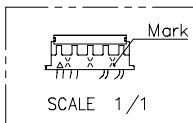
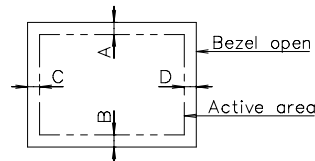

5. Do not wrap conductive tapes around the backlight wires.

Product Specification

## 6. Reliability

Environment test condition

No	Test Item	Condition
1	High temperature storage test	Ta= 60°C 240h
2	Low temperature storage test	Ta= -20°C 240h
3	High temperature operation test	Ta= 50°C 50%RH 240h
4	Low temperature operation test	Ta= 0°C 240h
5	Vibration test (non-operating)	Wave form : random Vibration level : 1.0G RMS Bandwidth : 10-500Hz Duration : X,Y,Z, 20 min One time each direction
6	Shock test (non-operating)	Shock level : 100G Waveform : half sine wave, 2ms Direction : ±X, ±Y, ±Z One time each direction
7	Altitude operating storage / shipment	0 - 10,000 feet(3048m) 0 - 40,000 feet(12,192m)

## 7. International Standards

### 7-1. Safety

- a) UL 1950 Third Edition, Underwriters Laboratories, Inc. Jan. 28, 1995.  
Standard for Safety of Information Technology Equipment Including Electrical Business Equipment.
- b) CAN/CSA C22.2 No. 950-95 Third Edition, Canadian Standards Association, Jan. 28, 1995.  
Standard for Safety of Information Technology Equipment Including Electrical Business Equipment.
- c) EN 60950 : 1992+A1: 1993+A2: 1993+A3: 1995+A4: 1997+A11: 1997  
IEC 950 : 1991+A1: 1992+A2: 1993+A3: 1995+A4: 1996  
European Committee for Electrotechnical Standardization(CENELEC)  
EUROPEAN STANDARD for Safety of Information Technology Equipment Including Electrical Business Equipment.

### 7-2. EMC

- a) ANSI C63.4 "Methods of Measurement of Radio-Noise Emissions from Low-Voltage Electrical and Electrical Equipment in the Range of 9kHz to 40GHz." American National Standards Institute(ANSI), 1992
- b) C.I.S.P.R "Limits and Methods of Measurement of Radio Interface Characteristics of Information Technology Equipment." International Special Committee on Radio Interference.
- c) EN 55022 "Limits and Methods of Measurement of Radio Interface Characteristics of Information Technology Equipment." European Committee for Electrotechnical Standardization.(CENELEC), 1998

Product Specification

## 8. Packing

### 8-1. Designation of Lot Mark

a) Lot Mark

A	B	C	D	E	F	G	H	I	J	K	L	M
---	---	---	---	---	---	---	---	---	---	---	---	---

A,B,C : SIZE

D : YEAR

E : MONTH

F,G : PANEL CODE

H : ASSEMBLY CODE

I,J,K,L,M : SERIAL NO.

Note

1. YEAR

Year	97	98	99	2000	2001	2002	2003	2004	2005	2006	2007
Mark	7	8	9	0	1	2	3	4	5	6	7

2. MONTH

Month	Jan	Feb	Mar	Apr	May	Jun	Jul	Aug	Sep	Oct	Nov	Dec
Mark	1	2	4	4	5	6	7	8	9	A	B	C

3. Serial No.

Year	1 ~ 99999	100000 ~
Mark	00001 ~ 99999	A0001 ~ A9999, ..... , Z9999

b) Location of Lot Mark

Serial NO. is printed on the label. The label is attached to the backside of the LCD module.  
This is subject to change without prior notice.

### 8-2. Packing Form

a) Package quantity in one box : 3 pcs

b) Box Size : 470mm × 253mm × 573mm



## 9. PRECAUTIONS

Please pay attention to the followings when you use this TFT LCD module.

### 9-1. MOUNTING PRECAUTIONS

- (1) You must mount a module using holes arranged in four corners or four sides.
- (2) You should consider the mounting structure so that uneven force (ex. Twisted stress) is not applied to the module. And the case on which a module is mounted should have sufficient strength so that external force is not transmitted directly to the module.
- (3) Please attach the surface transparent protective plate to the surface in order to protect the polarizer. Transparent protective plate should have sufficient strength in order to resist external force.
- (4) You should adopt radiation structure to satisfy the temperature specification.
- (5) Acetic acid type and chlorine type materials for the cover case are not desirable because the former generates corrosive gas of attacking the polarizer at high temperature and the latter causes circuit break by electro-chemical reaction.
- (6) Do not touch, push or rub the exposed polarizers with glass, tweezers or anything harder than HB pencil lead. And please do not rub with dust clothes with chemical treatment. Do not touch the surface of polarizer for bare hand or greasy cloth. (Some cosmetics are detrimental to the polarizer.)
- (7) When the surface becomes dusty, please wipe gently with absorbent cotton or other soft materials like chamois soaks with petroleum benzene. Normal-hexane is recommended for cleaning the adhesives used to attach front / rear polarizers. Do not use acetone, toluene and alcohol because they cause chemical damage to the polarizer.
- (8) Wipe off saliva or water drops as soon as possible. Their long time contact with polarizer causes deformations and color fading.
- (9) Do not open the case because inside circuits do not have sufficient strength.

### 9-2. OPERATING PRECAUTIONS

- (1) The spike noise causes the mis-operation of circuits. It should be lower than following voltage :  
 $V = \pm 200\text{mV}$  (Over and under shoot voltage)
- (2) Response time depends on the temperature. (In lower temperature, it becomes longer.)
- (3) Brightness depends on the temperature. (In lower temperature, it becomes lower.)  
And in lower temperature, response time (required time that brightness is stable after turned on) becomes longer.
- (4) Be careful for condensation at sudden temperature change. Condensation makes damage to polarizer or electrical contacted parts. And after fading condensation, smear or spot will occur.
- (5) When fixed patterns are displayed for a long time, remnant image is likely to occur.
- (6) Module has high frequency circuits. Sufficient suppression to the electromagnetic interference shall be done by system manufacturers. Grounding and shielding methods may be important to minimize the interference.
- (7) Please do not give any mechanical and/or acoustical impact to LCM. Otherwise, LCM can not be operated its full characteristics perfectly.
- (8) A screw which is fastened up the steels should be a machine screw (if not, it causes metal foreign material and deal LCM a fatal blow)

### 9-3. ELECTROSTATIC DISCHARGE CONTROL

Since a module is composed of electronic circuits, it is not strong to electrostatic discharge. Make certain that treatment persons are connected to ground through wrist band etc. And don't touch interface pin directly.

### 9-4. PRECAUTIONS FOR STRONG LIGHT EXPOSURE

Strong light exposure causes degradation of polarizer and color filter.

### 9-5. STORAGE

When storing modules as spares for a long time, the following precautions are necessary.

- (1) Store them in a dark place. Do not expose the module to sunlight or fluorescent light. Keep the temperature between 5°C and 35°C at normal humidity.
- (2) The polarizer surface should not come in contact with any other object.  
It is recommended that they be stored in the container in which they were shipped.

### 9-6. HANDLING PRECAUTIONS FOR PROTECTION FILM

- (1) The protection film is attached to the bezel with a small masking tape.  
When the protection film is peeled off, static electricity is generated between the film and polarizer. This should be peeled off slowly and carefully by people who are electrically grounded and with well ion-blown equipment or in such a condition, etc.
- (2) When the module with protection film attached is stored for a long time, sometimes there remains a very small amount of glue still on the bezel after the protection film is peeled off.
- (3) You can remove the glue easily. When the glue remains on the bezel surface or its vestige is recognized, please wipe them off with absorbent cotton waste or other soft material like chamois soaked with normal-hexane.