

DESCRIPTION

The HY514400 is the new generation and fast dynamic RAM organized 1,048,576 x 4 bits. The HY514400 utilizes Hyundai's CMOS silicon gate process technology as well as advanced circuit techniques to provide wide operating margins to the users. Multiplexed address inputs permit the HY514400 to be packaged in a standard 20/26 pin plastic SOJ.

The package size provides high system bit densities and is compatible with widely available automated-test equipments. System oriented-feature includes single power supply of $5V \pm 10\%$ tolerance and direct interfacing capability with high performance logic families such as Schottky TTL.

FEATURES

- Low power dissipation
Max. CMOS standby 5.5mW
Max. TTL standby 11.0mW
Max. operating

Speed	Power
70	522.5mW
80	467.5mW
10	412.5mW

- Single power supply of $5V \pm 10\%$
- TTL compatible inputs and outputs
- Fast access Time

Speed	t _{RAC}	t _{CAC}	t _{PC}
70	70ns	20ns	50ns
80	80ns	25ns	50ns
10	100ns	25ns	60ns

- Fast page mode operation
- Multi-bit test capability
- Read-Modify-Write capability
- CAS-before-RAS, RAS-only, Hidden refresh
- 1024 refresh cycles / 16ms

PIN DESCRIPTION

RAS	Row Address Strobe
CAS	Column Address Strobe
WE	Write Enable
OE	Output Enable
A0-A9	Address Input
DQ0-DQ3	Data Input/Output
VCC	Power (+ 5V)
VSS	Ground

PIN CONNECTION

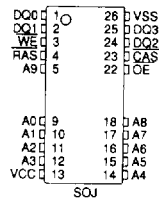

BLOCK DIAGRAM

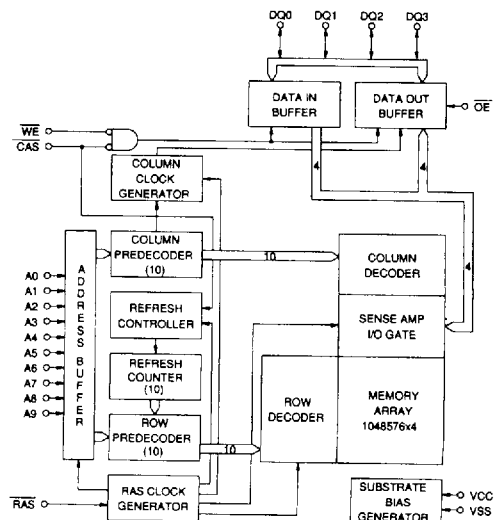

This document is a general product description and is subject to change without notice. Hyundai electronics does not assume any responsibility for use of circuits described. No patent licences are implied.

1AC02-30-MAY94

ABSOLUTE MAXIMUM RATINGS

SYMBOL	PARAMETER	RATING	UNIT
TA	Ambient Temperature	0 to 70	°C
TSTG	Storage Temperature	-55 to 150	°C
VIN, VOUT	Voltage on Any Pin Relative to Vss	-1.0 to 7.0	V
VCC	Voltage on Vcc Relative to Vss	-1.0 to 7.0	V
IOS	Short Circuit Output Current	50	mA
Pd	Power Dissipation	0.67	W
TSOLDER	Soldering Temperature• Time	260•10	°C•sec

NOTE : Operation at or above Absolute Maximum Ratings can adversely affect device reliability.

RECOMMENDED DC OPERATING CONDITIONS

(TA= 0°C to 70°C)

SYMBOL	PARAMETER	MIN.	TYP.	MAX.	UNIT
VCC	Supply Voltage	4.5	5.0	5.5	V
VIH	Input High Voltage	2.4	-	VCC+ 1.0	V
VIL	Input Low Voltage	-1.0	-	0.8	V

NOTE : All voltages are referenced to Vss.

DC CHARACTERISTICS

(TA= 0°C to 70°C, VCC= 5V± 10%, VSS= 0V, unless otherwise noted.)

SYMBOL	PARAMETER	TEST CONDITIONS	SPEED	MIN.	MAX.	UNIT	NOTE
ILI	Input Leakage Current (Any Input Pins)	VSS ≤ VIN ≤ 6.5V, All other pins not under test= VSS		-10	10	μA	
ILO	Output Leakage Current (High Impedance State)	VSS ≤ VOUT ≤ 5.5V, RAS & CAS at VIH		-10	10	μA	
ICC1	VCC Supply Current, Operating	trc= trc (min.)	70	-	95	mA	1,2,3
			80	-	85		
			10	-	75		
ICC2	VCC Supply Current, TTL Standby	RAS & CAS at VIH		-	2	mA	
ICC3	VCC Supply Current, RAS-only refresh	trc= trc (min.)	70	-	95	mA	1,3
			80	-	85		
			10	-	75		
ICC4	VCC Supply Current, Fast Page mode	tpc= tpc (min.)	70	-	80	mA	1,2,3
			80	-	70		
			10	-	60		
ICC5	VCC Supply Current, CMOS Standby	RAS & CAS ≤ VCC-0.2V		-	1	mA	
ICC6	VCC Supply Current, CAS-before-RAS refresh	trc= trc (min.)	70	-	95	mA	1,3
			80	-	85		
			10	-	75		
VOL	Output Low Voltage	IOL= 4.2mA		-	0.4	V	
VOH	Output High Voltage	IOH= -5mA		2.4	-	V	

NOTE :

1. ICC1, ICC3, ICC4, and ICC6 depend on cycle rate.
2. ICC1 and ICC4 depend on output loading. Specified values are obtained with the output open.
3. It depends on user whether column address is changed or not at least once while RAS= VIL and CAS= VIH.

AC CHARACTERISTICS

(TA= 0°C to 70°C, VCC= 5V± 10%, VSS= 0V, unless otherwise noted.) NOTE : 1, 2, 3

#	SYMBOL	PARAMETER	HY514400J						UNIT	NOTE
			-70		-80		-10			
			MIN.	MAX.	MIN.	MAX.	MIN.	MAX.		
1	tRC	Random Read or Write Cycle Time	130	-	150	-	180	-	ns	
2	tRWC	Read-Modify-Write Cycle Time	185	-	210	-	245	-	ns	
3	tPC	Fast Page Mode Cycle Time	50	-	50	-	60	-	ns	
4	tPRWC	Fast Page Mode Read-Modify-Write Cycle Time	105	-	115	-	125	-	ns	
5	tRAC	Access Time from RAS	-	70	-	80	-	100	ns	4,9,10
6	tCAC	Access Time from CAS	-	20	-	25	-	25	ns	4,9
7	tAA	Access Time from Column Address	-	35	-	40	-	45	ns	4,10
8	tCPA	Access Time from CAS Precharge	-	45	-	45	-	55	ns	4
9	tCLZ	CAS to Output Low Impedance	0	-	0	-	0	-	ns	4
10	tOFF	Output Buffer Turn-off Delay	0	20	0	20	0	20	ns	5
11	tT	Transition Time (Rise and Fall)	3	50	3	50	3	50	ns	3
12	tRP	RAS Precharge Time	50	-	60	-	70	-	ns	
13	tRAS	RAS Pulse Width	70	10K	80	10K	100	10K	ns	
14	tRASP	RAS Pulse Width (Fast Page Mode)	70	200K	80	200K	100	200K	ns	
15	tRSH	RAS Hold Time	20	-	25	-	25	-	ns	
16	tCSH	CAS Hold Time	70	-	80	-	100	-	ns	
17	tCAS	CAS Pulse Width	20	10K	25	10K	25	10K	ns	
18	tRCD	RAS to CAS Delay	20	50	20	55	25	75	ns	9
19	tRAD	RAS to Column Address Delay Time	15	35	15	40	20	55	ns	10
20	tCRP	CAS to RAS Precharge Time	5	-	5	-	10	-	ns	
21	tCP	CAS Precharge Time	10	-	10	-	10	-	ns	
22	tASR	Row Address Set-up Time	0	-	0	-	0	-	ns	
23	tRAH	Row Address Hold Time	10	-	10	-	15	-	ns	
24	tASC	Column Address Set-up Time	0	-	0	-	0	-	ns	
25	tCAH	Column Address Hold Time	15	-	15	-	20	-	ns	
26	tAR	Column Address Hold Time from RAS	55	-	60	-	80	-	ns	
27	tRAL	Column Address to RAS Lead Time	35	-	40	-	45	-	ns	
28	tRCS	Read Command Set-up Time	0	-	0	-	0	-	ns	
29	tRCH	Read Command Hold Time Referenced to CAS	0	-	0	-	0	-	ns	6
30	tRRH	Read Command Hold Time Referenced to RAS	0	-	0	-	0	-	ns	6
31	tWCH	Write Command Hold Time	15	-	15	-	20	-	ns	
32	tWCR	Write Command Hold Time from RAS	55	-	60	-	80	-	ns	
33	tWP	Write Command Pulse Width	15	-	15	-	20	-	ns	
34	tRWL	Write Command to RAS Lead Time	20	-	25	-	25	-	ns	
35	tCWL	Write Command to CAS Lead Time	20	-	25	*	25	-	ns	
36	tDS	Data-In Set-up Time	0	-	0	-	0	-	ns	7
37	tDH	Data-In Hold Time	15	-	15	-	20	-	ns	7
38	tDHR	Data-In Hold Time Referenced to RAS	55	-	60	-	80	-	ns	
39	tREF	Refresh Period (1024 cycles)	-	16	-	16	-	16	ms	
40	tWCS	Write Command Set-up Time	0	-	0	-	0	-	ns	8

AC CHARACTERISTICS

(continued)

#	SYMBOL	PARAMETER	HY514400J						UNIT	NOTE
			-70		-80		-10			
			MIN.	MAX.	MIN.	MAX.	MIN.	MAX.		
41	tCWD	CAS to WE Delay Time	50	-	55	-	60	-	ns	8
42	tRWD	RAS to WE Delay Time	100	-	110	-	135	-	ns	8
43	tAWD	Column Address to WE Delay Time	65	-	70	-	80	-	ns	8
44	tCSR	CAS Set-up Time (CBR Cycle)	10	-	10	-	10	-	ns	
45	tCHR	CAS Hold Time (CBR Cycle)	30	-	30	-	30	-	ns	
46	tRPC	RAS to CAS Precharge Time	0	-	0	-	0	-	ns	
47	tCPT	CAS Precharge Time (CBR Counter Test)	40	-	40	-	50	-	ns	
48	tROH	RAS Hold Time Referenced to \overline{OE}	10	-	10	-	20	20	ns	
49	tOEA	\overline{OE} Access Time	-	20	-	20	-	25	ns	
50	tOED	\overline{OE} to Data Delay	20	-	20	-	25	-	ns	
51	tO EZ	Output Buffer Turn Off Delay Time from \overline{OE}	0	20	0	20	0	20	ns	5
52	tOEH	\overline{OE} Command Hold Time	20	-	20	-	25	-	ns	
53	tCPWD	WE Delay Time from CAS Precharge	10	-	10	-	10	-	ns	8
54	tRHCP	RAS Hold Time from CAS Precharge	10	-	10	-	10	-	ns	
55	tWRP	WE to RAS Precharge Time (CBR Cycle)	10	-	10	-	10	-	ns	
56	tWRH	WE to RAS Hold Time (CBR Cycle)	10	-	10	-	10	-	ns	
57	tWTS	Write Command Set-up Time (Test Mode In)	70	-	75	-	85	-	ns	
58	tWTH	Write Command Hold Time (Test Mode In)	40	-	45	-	50	-	ns	

AC CHARACTERISTICS IN TEST MODE NOTE : 11

#	SYMBOL	PARAMETER	HY514400J						UNIT	NOTE
			-70		-80		-10			
			MIN.	MAX.	MIN.	MAX.	MIN.	MAX.		
1	tRC	Random Read or Write Cycle Time	135	-	155	-	185	-	ns	
2	tRWC	Read-Modify-Write Cycle Time	190	-	215	-	250	-	ns	
3	tPC	Fast Page Mode Cycle Time	55	-	55	-	65	-	ns	
4	tPRWC	Fast Page Mode Read-Modify-Write Cycle Time	110	-	120	-	130	-	ns	
5	tRAC	Access Time from RAS	-	75	-	85	-	105	ns	4,9,10
6	tCAC	Access Time from CAS	-	25	-	30	-	30	ns	4,9
7	tAA	Access Time from Column Address	-	40	-	45	-	50	ns	4,10
8	tCPA	Access Time from CAS Precharge	-	50	-	50	-	60	ns	4
13	tRAS	RAS Pulse Width	75	10K	85	10K	105	10K	ns	
14	tRASP	RAS Pulse Width (Fast Page Mode)	75	200K	85	200K	105	200K	ns	
15	tRSH	RAS Hold Time	25	-	30	-	30	-	ns	
16	tCSH	CAS Hold Time	75	-	85	-	105	-	ns	
17	tCAS	CAS Pulse Width	25	10K	30	10K	30	10K	ns	
27	tRAL	Column Address to RAS Lead Time	35	-	45	-	50	-	ns	
41	tCWD	CAS to WE Delay Time	55	-	60	-	65	-	ns	8
42	tRWD	RAS to WE Delay Time	105	-	115	-	140	-	ns	8
43	tAWD	Column Address to WE Delay Time	70	-	75	-	85	-	ns	8
49	tOEA	OE Access Time	-	25	-	25	-	30	ns	
50	tOED	OE to Data Delay	25	-	25	-	30	-	ns	
52	tOEH	OE Command Hold Time	25	-	25	-	30	-	ns	

NOTE :

1. An initial pause of 200 μ s is required after power-up followed by 8 **FAS** cycles before proper device operation is achieved. In case of using internal refresh counter, a minimum of 8 **CAS-before-FAS** initialization cycles instead of 8 **FAS-only** refresh cycles are required. The device should be carefully initialized to be prevented from being entered into multi bit test mode during initialization.
2. AC measurements assume $t_T = 5$ ns.
3. $V_{IH}(\text{min.})$ and $V_{IL}(\text{max.})$ are reference levels for measuring timing of input signals. Also, transition times are measured between V_{IH} and V_{IL} .
4. Measured with a load equivalent to 2 TTL loads and 100pF.
5. $t_{OFF}(\text{max.})$ and t_{OEZ} define the time at which the output achieves the open circuit condition and is not referenced to output voltage levels.
6. Either t_{RCH} or t_{RRH} must be satisfied for a read cycle.
7. These parameters are referenced to **CAS** leading edge in early write cycles and to **WE** leading edge in Read-Modify-Write cycles.
8. t_{WCS} , t_{RWD} , t_{CWD} , t_{AWD} and t_{CPWD} are not restrictive operating parameters. They are included in the data sheet as electrical characteristics only. If $t_{WCS} \geq t_{WCS}(\text{min.})$, the cycle is an early write cycle and data out pin will remain open circuit (high impedance) through the entire cycle. If $t_{RWD} \geq t_{RWD}(\text{min.})$, $t_{CWD} \geq t_{CWD}(\text{min.})$, $t_{AWD} \geq t_{AWD}(\text{min.})$, and $t_{CPWD} \geq t_{CPWD}(\text{min.})$, the cycle is a Read-Modify-Write cycle and data out will contain data read from the selected cell. If neither of the above sets of conditions is satisfied, the condition of the data out (at access time) is indeterminated.
9. Operation within the $t_{RCD}(\text{max.})$ limit insures that $t_{RAC}(\text{max.})$ can be met. $t_{RCD}(\text{max.})$ is specified as a reference point only. If t_{RCD} is greater than the specified $t_{RCD}(\text{max.})$ limit, then access time is controlled by t_{CAC} .
10. Operation within the $t_{RAD}(\text{max.})$ limit insures that $t_{RAC}(\text{max.})$ can be met. $t_{RAD}(\text{max.})$ is specified as a reference point only. If t_{RAD} is greater than the specified $t_{RAD}(\text{max.})$ limit, then access time is controlled by t_{AA} .
11. These specifications are applied to the Test Mode.

CAPACITANCE

($T_A = 25^\circ\text{C}$, $V_{CC} = 5\text{V} \pm 10\%$, $V_{SS} = 0\text{V}$, $f = 1\text{MHz}$, unless otherwise noted.)

SYMBOL	PARAMETER	TYP.	MAX.	UNIT
CIN1	Input Capacitance (A0-A9, D)	-	5	pF
CIN2	Input Capacitance (FAS, CAS, WE, OE)	-	7	pF
COUT	Output Capacitance (Q)	-	7	pF

TIMING DIAGRAM

READ CYCLE

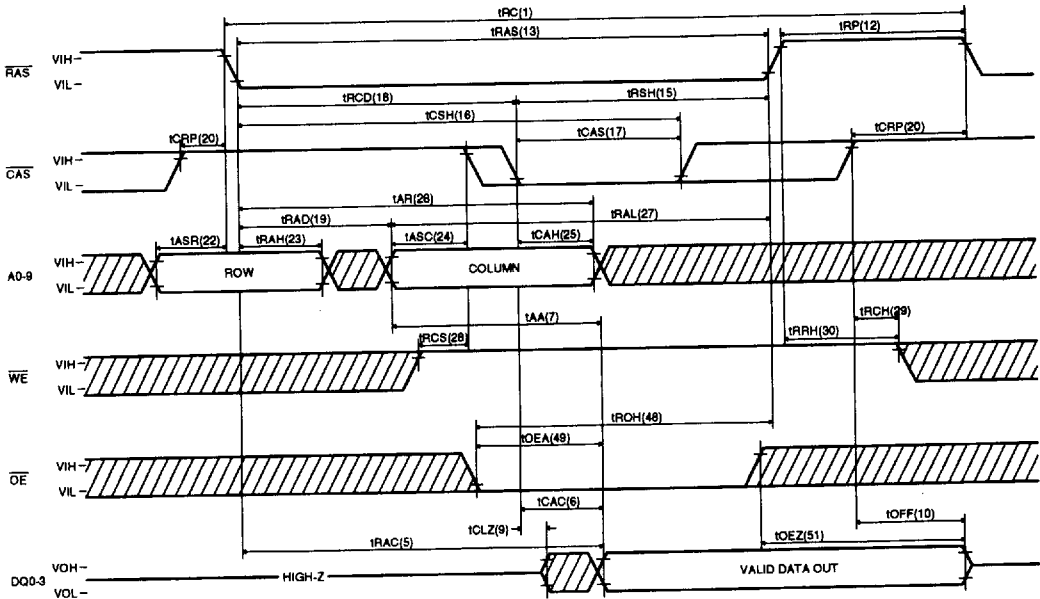

EARLY WRITE CYCLE

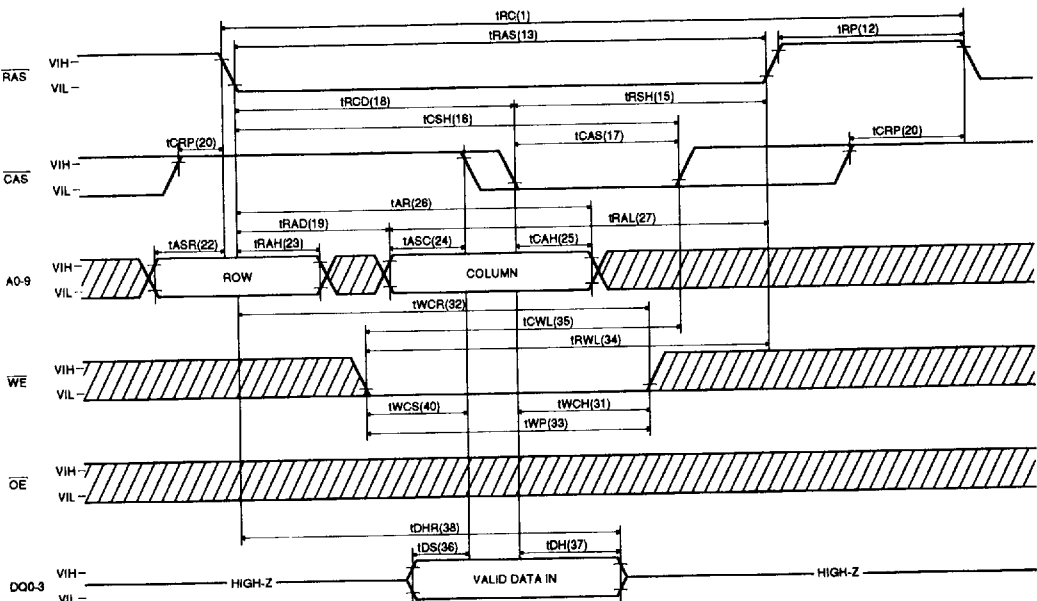

WRITE CYCLE (OE CONTROLLED WRITE)

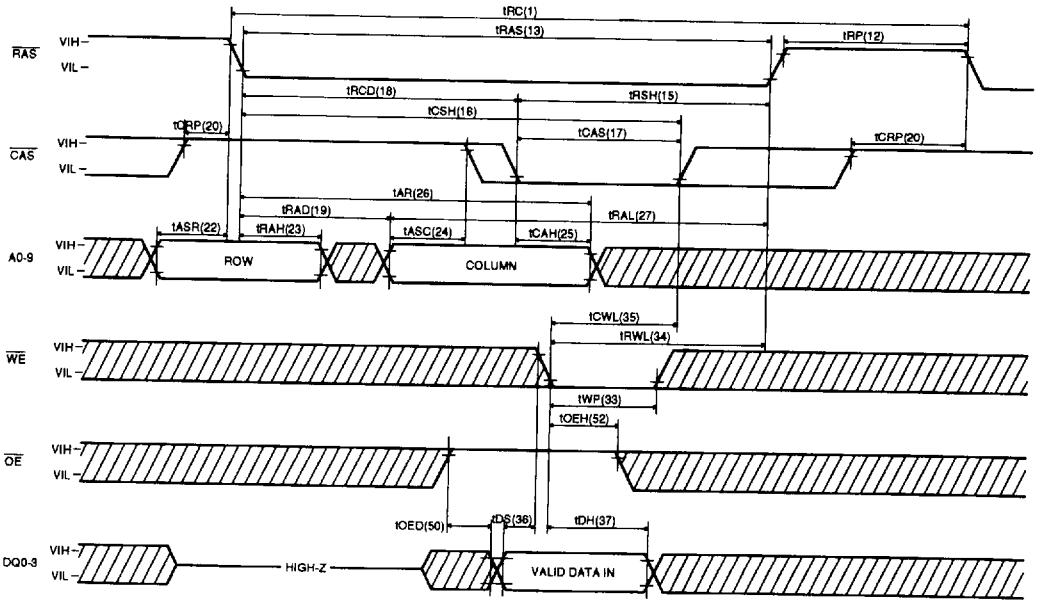

READ-MODIFY-WRITE CYCLE

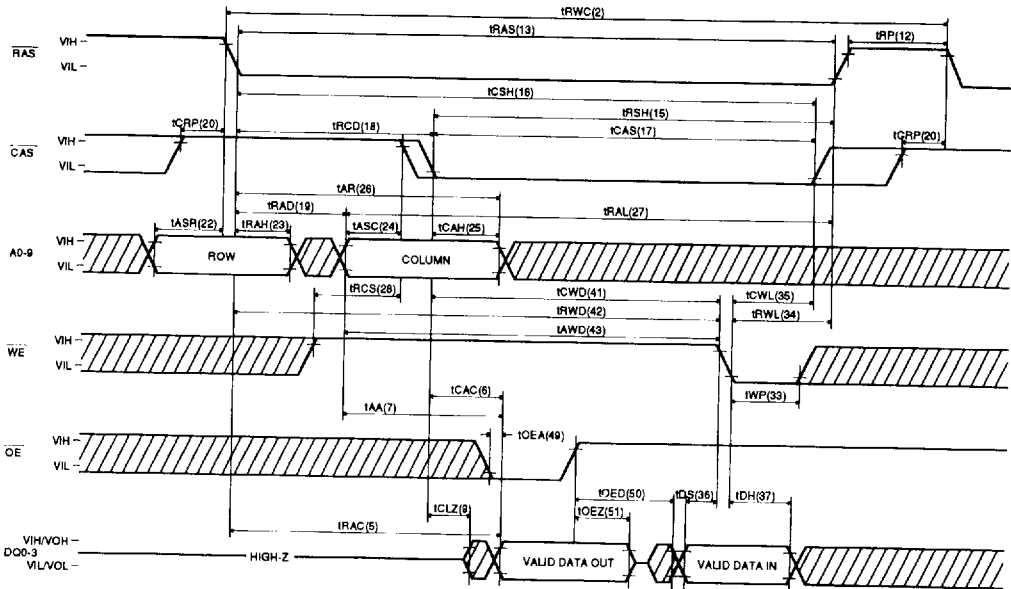

CAS-BEFORE-RAS REFRESH CYCLE

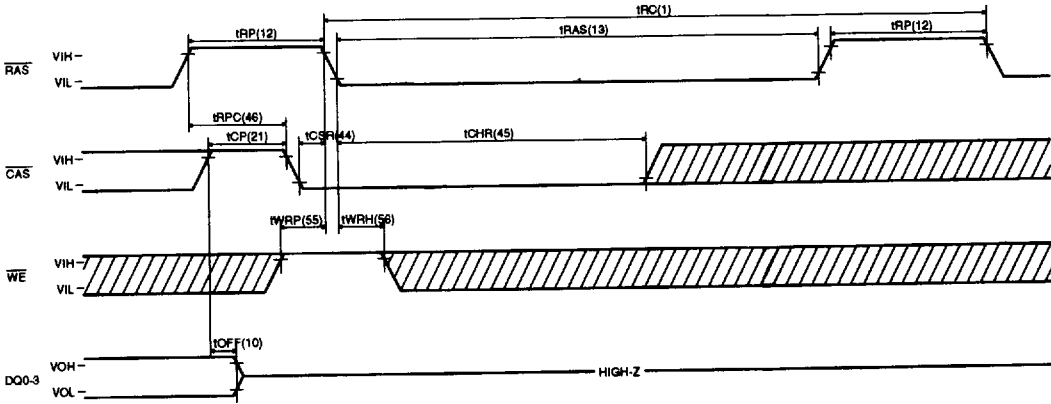

NOTE : A0-9 and OE = "H" or "L"

HIDDEN REFRESH CYCLE (READ)

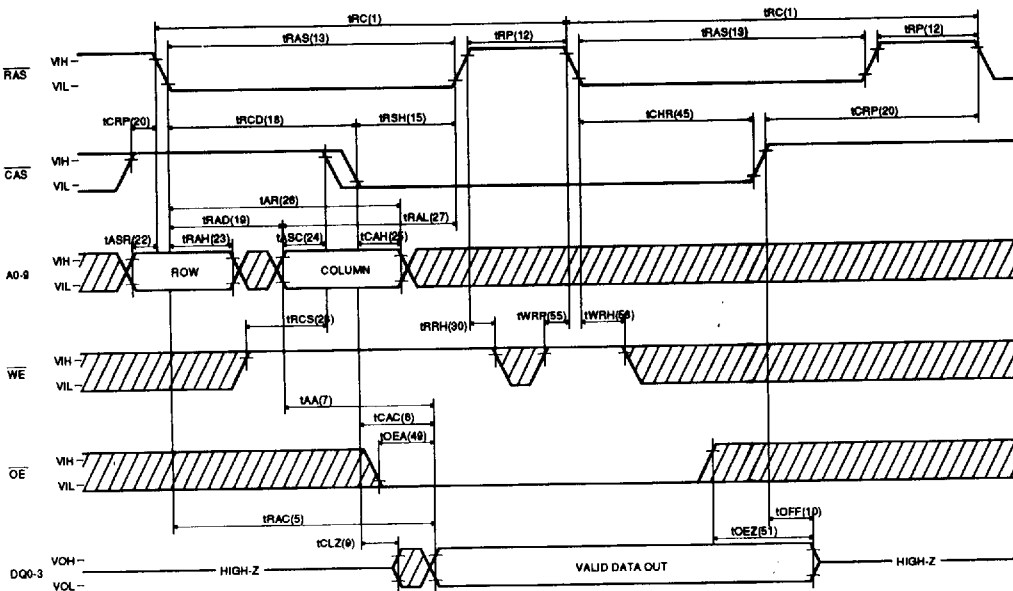

HIDDEN REFRESH CYCLE (WRITE)

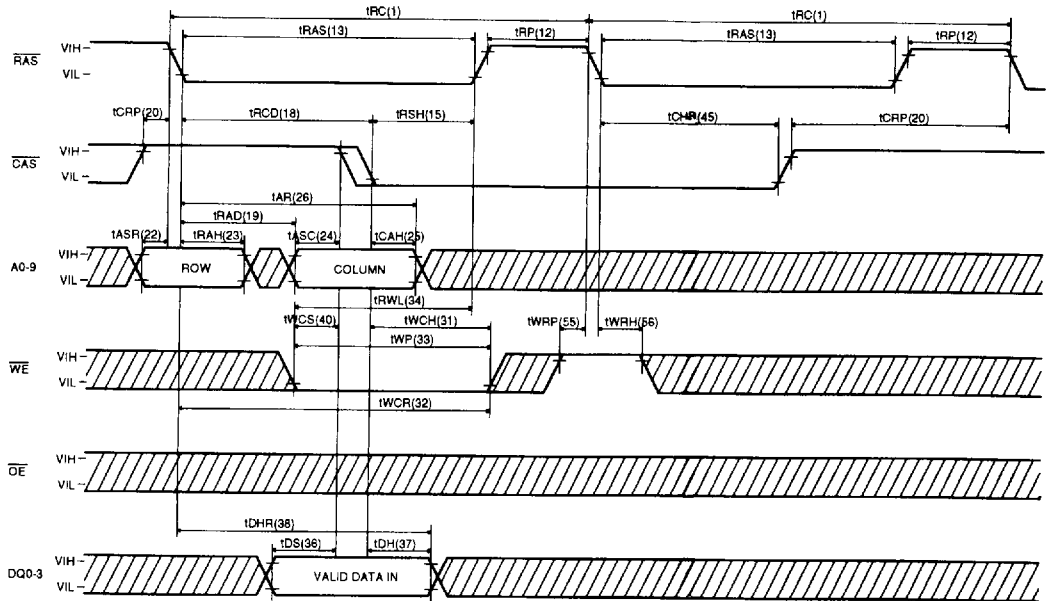

CAS-BEFORE-RAS REFRESH COUNTER TEST CYCLE

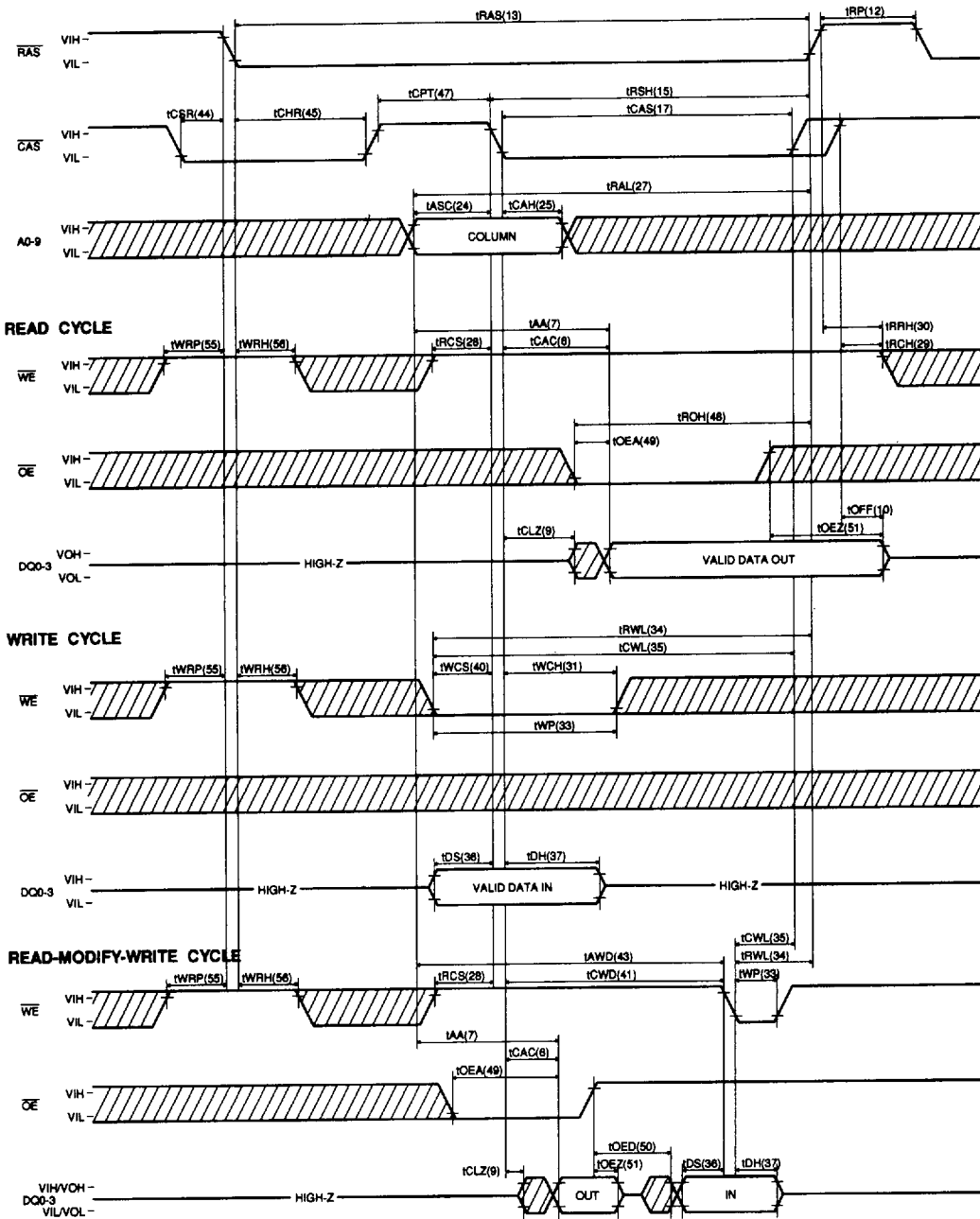

TEST MODE

The HY514400A is a DRAM organized 1,048,576 x 4-bit. It is internally organized 524,288 x 8-bit. In Test Mode, data are written into 8 sectors (Each is composed of 512K bits) in parallel and retrieved the same way. Column address A0 is not used. If, upon reading, all 8-bit data from 8 sectors are equal (all "1"s or "0"s), the DQ2 pin indicates a "1". If they are not equal, the DQ2 pin indicates a "0". The DQ0, DQ1 and DQ3 pins always indicate a "1" in Test Mode Read cycles. The diagram below shows the timing of the HY514400A to enter Test Mode. In Test Mode, the 1Mx4 DRAM can be tested as if it were a 512Kx4 DRAM. WE, CAS-before-RAS cycle (Test Mode In Cycle) puts the HY514400A into Test Mode. CAS-before-RAS or RAS-only refresh cycle puts it back into Normal Mode. In Test Mode, WE, CAS-before-RAS cycle shall be used for the refresh operation. The Test Mode function reduces test time.(1/2 in case of N test pattern)

TEST MODE IN CYCLE

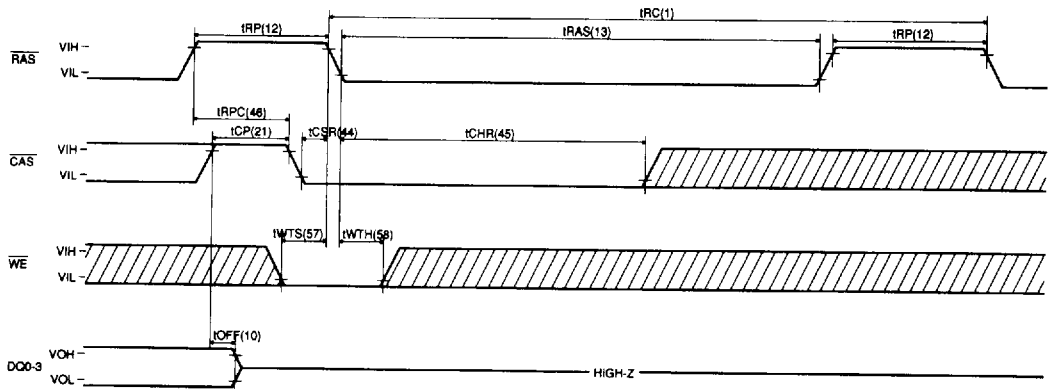

BLOCK DIAGRAM IN TEST MODE

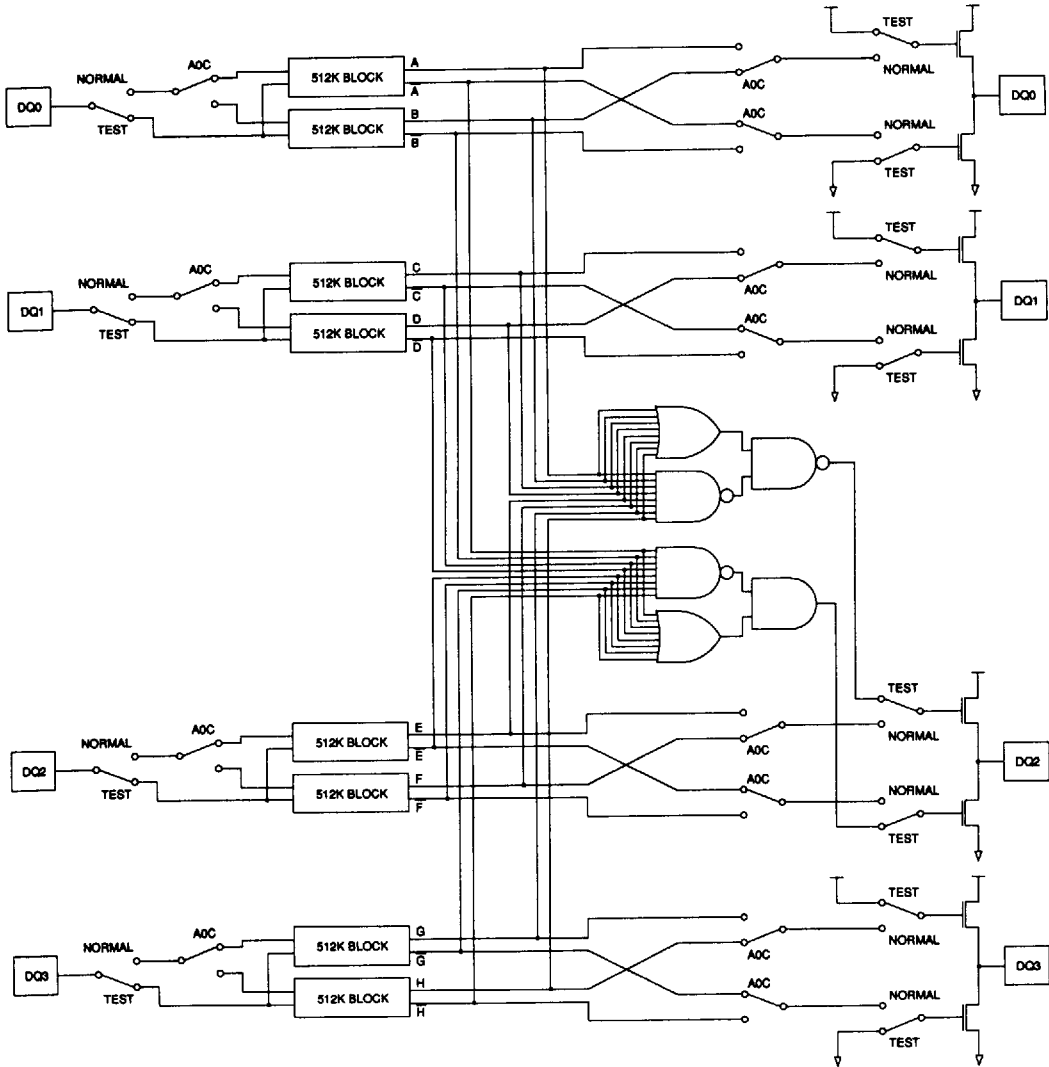

PACKAGE INFORMATION

300 mil 20/26 pin Small Outline J-form Package (J)

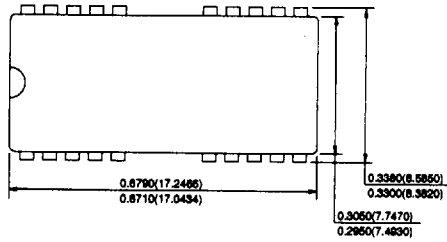

UNIT : INCH(mm)

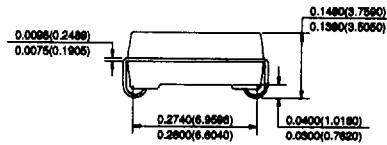
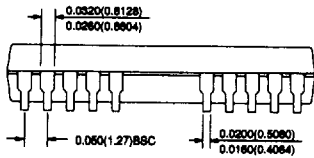

ORDERING INFORMATION

PART NO	SPEED	POWER	PACKAGE
HY514400J	70/80/10		SOJ