

# mass integrated

global part distribution • product lifecycle partner  
excess inventory management • value-ad service provider



Data sheet provided by Mass Integrated

[massintegrated.com](http://massintegrated.com) • [displayalliance.com](http://displayalliance.com)

Please call +1.978.465.6190  
Email: [sales@massintegrated.com](mailto:sales@massintegrated.com)



ISO 9001: 2008

Mass Integrated complies with all DMCA takedown notices. Please send a formal DMCA Takedown Notice to Mass Integrated Systems, Inc. • 18 Henry Graf Jr. Road, Unit 1 • Newburyport, MA 01950.



**PROPRIETARY NOTE**

THIS SPECIFICATION IS THE PROPERTY OF HYDIS AND SHALL NOT BE REPRODUCED OR COPIED WITHOUT THE WRITTEN PERMISSION OF HYDIS AND MUST BE RETURNED TO HYDIS UPON ITS REQUEST

**TITLE : HT121WX2-103**

**Product Specification**

**Rev. D**

**HYDIS TECHNOLOGIES**

SPEC. NUMBER  
S864-1264

PRODUCT GROUP  
TFT-LCD PRODUCTS

REV.  
D

ISSUE DATE  
2008. 04. 28

PAGE  
1/ 27



# PRODUCT GROUP

REV

ISSUE DATE

TFT-LCD PRODUCT

D

2008.04.28

## REVISION HISTORY

REV.	ECN NO.	DESCRIPTION OF CHANGES	DATE	PREPARED
0		.Initial Release	05.12.28	C.Y.Cho
A	E0611-F022	.Repositioning the Product Label (p.23) : Left and down side → Center and down side	06.12.26	Joseph Ha
B	E0704-F016	.Adding the Optical data (p.8) : Minimum value of Viewing Angle & Contrast Ratio Maximum value of Response Time .Elimination of Product Label for BOE China (p.23)	07.04.27	Joseph Ha
C	E0710-F018	.Correcting White Luminance definition : Note3 5points → Center (p.9)	07.10.24	Joseph Ha
D	E0804-F007	.Correction of polarizer type : Anti-Glare → Glare (p.5) . Correction of page error (after p.3)	08.04.28	Joseph Ha

SPEC. NUMBER  
S864-1264SPEC. TITLE  
HT121WX2-103 Product SpecificationPAGE  
2/ 27



# PRODUCT GROUP

REV

ISSUE DATE

TFT-LCD PRODUCT

D

2008.04.28

## CONTENS

NO.	ITEM	PAGE
1.0	General Description	4
2.0	Absolute Maximum ratings	6
3.0	Electrical specifications	7
4.0	Optical specifications	8
5.0	Interface Connection	12
6.0	Signal Timing Specification	14
7.0	Signal Timing waveforms of interface signal (DE mode)	15
8.0	Input Signals, Display Colors & Gray Scale of Colors	16
9.0	Power Sequence	17
10.0	Mechanical Characteristics	18
11.0	Reliability Test	19
12.0	Handling & Cautions	20
13.0	Packing	21
14.0	Environment & Safety	22
15.0	TFT-LCD Module Outline Dimensions	24
16.0	EDID data	26

SPEC. NUMBER  
S864-1264

SPEC. TITLE  
HT121WX2-103 Product Specification

PAGE  
3 / 27



# PRODUCT GROUP

REV

ISSUE DATE

TFT-LCD PRODUCT

D

2008.04.28

## 1.0 GENERAL DESCRIPTION

### 1.1 Introduction

HT121WX2-103 is a color active matrix TFT LCD module using amorphous silicon TFT's (Thin Film Transistors) as an active switching devices. This module has a 12.1 inch diagonally measured active area with WXGA resolutions (1280 horizontal by 800 vertical pixel array). Each pixel is divided into RED, GREEN, BLUE dots which are arranged in vertical stripe and this module can display 262,144 colors. The TFT-LCD panel used for this module is a low reflection and higher color type.

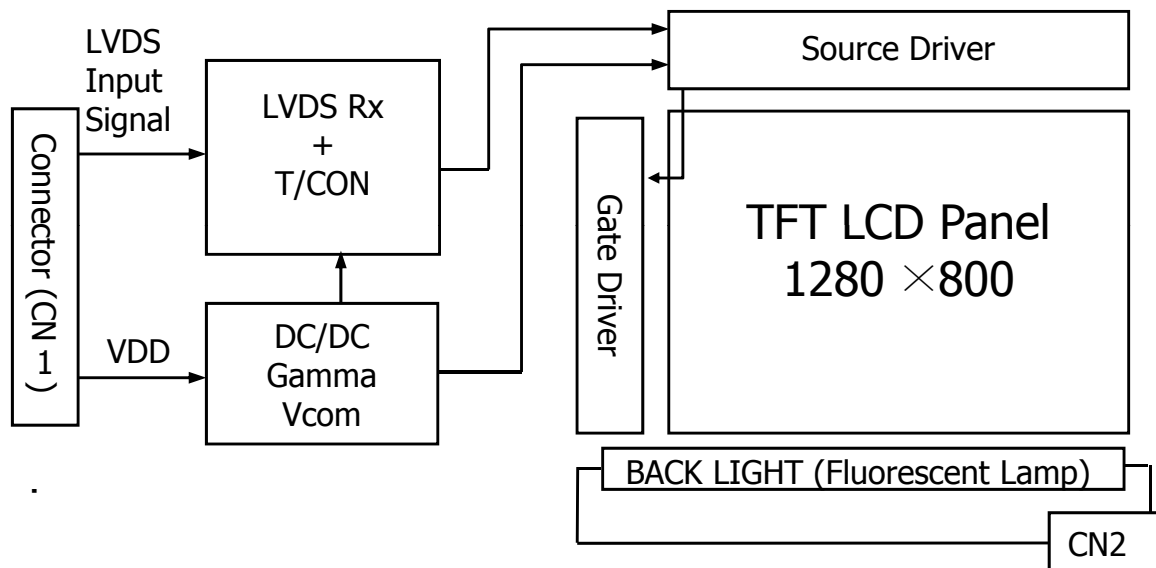

### 1.2 Features

- 1) Thin and light weight
- 2) 6-bit color depth, Display 262,144 colors
- 3) Low driving voltage and low power consumption
- 4) 1 Channel LVDS Interface (DE mode)
- 6) Single CCFL (Bottom side/Horizontal Direction)
- 7) Al Bezel
- 8) On Board EDID chip
- 9) Glare polarizer product
- 10) VESA V1 Compatible
- 11) RoHS Product

### 1.3 Application

Notebook PC

SPEC. NUMBER  
S864-1264

SPEC. TITLE  
HT121WX2-103 Product Specification

PAGE  
4 / 27



# PRODUCT GROUP

REV

ISSUE DATE

TFT-LCD PRODUCT

D

2008.04.28

## 1.3 General Specifications

PARAMETER	SPECIFICATION	UNIT	REMARK
Active area	261.12(H) × 163.20(V)	mm	
Number of pixels	1280(H) × 800(V)	pixels	
Pixel pitch	0.204(H) × 0.204(V)	mm	
Pixel arrangement	RGB Vertical stripe		
Display colors	262,144	colors	
Display mode	Normally White		
Dimensional outline	275.8±0.5 (W) x 178.0±0.5 (V) Thickness : 4.9 Typ (5.2 Max)	mm	
Weight	260 Typ. / 270 Max.	g	
Back-light	Top edge side 1-CCFL type (Cold Cathode Fluorescent Lamp)		
Surface treatment	GlareReflection, 2H		

SPEC. NUMBER  
S864-1264SPEC. TITLE  
HT121WX2-103 Product SpecificationPAGE  
5 / 27



# PRODUCT GROUP

REV

ISSUE DATE

TFT-LCD PRODUCT

D

2008.04.28

## 2.0 ABSOLUTE MAXIMUM RATINGS

The followings are maximum values which, if exceed, may cause faulty operation or damage to the unit.

PARAMETER	SYMBOL	MIN.	MAX.	UNIT	REMARK
Logic Power Supply	$V_{DD}$	VSS-0.3	4.0	V	Ta = 25 ± 2 °C
Logic Input Voltage	$V_{IN}$	VSS-0.3	$V_{DD}+0.3$	V	
Back-light Lamp Current	$I_{BL}$	2.0	7.0	mA	
Back-light Frequency	$F_L$	45	80	KHz	
Operating Temperature	$T_{OP}$	0	+50	°C	Note 1
Storage Temperature	$T_{ST}$	-20	+60	°C	

Note 1. Temperature and relative humidity range are shown in the figure below.

- 90 [%] RH Max. ( $40^{\circ}\text{C} \geq T_a$ )
- Maximum wet-bulb temperature at 39 °C or less. ( $T_a > 40^{\circ}\text{C}$ ) No condensation

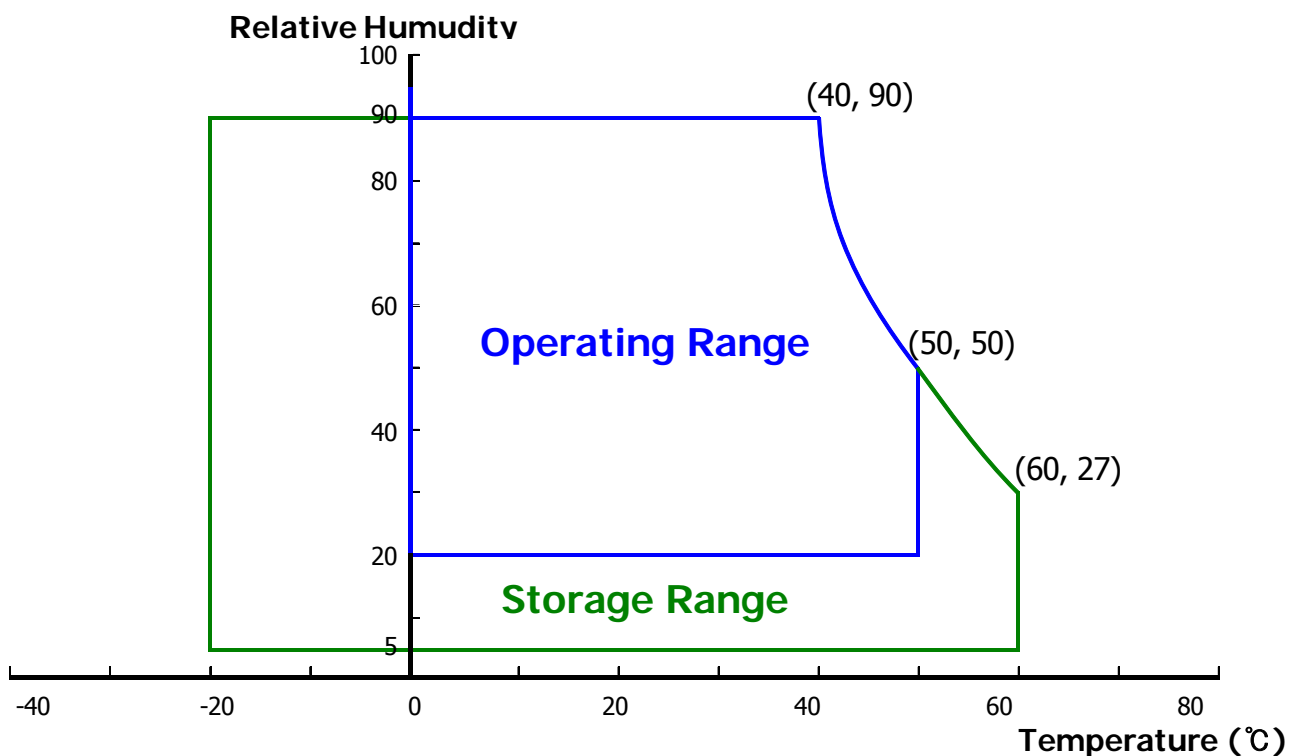

SPEC. NUMBER  
S864-1264

SPEC. TITLE  
HT121WX2-103 Product Specification

PAGE  
6 / 27



# PRODUCT GROUP

REV

ISSUE DATE

TFT-LCD PRODUCT

D

2008.04.28

## 3.0 ELECTRICAL SPECIFICATIONS

Ta = 25±2°C

PARAMETER		MIN.	TYP.	MAX.	UNIT	REMARK
Power Supply Voltage	V <sub>DD</sub>	3.0	3.3	3.6	V	Note 1
Power Supply Current	I <sub>DD</sub>	-	303	-	mA	Note 1
CCFL Ignition Time	t	-	-	1	Sec	
High Level Differential Input Signal Voltage	V <sub>IH</sub>	-	-	+100	mV	
Low Level Differential Input Signal Voltage	V <sub>IL</sub>	-100	-	-	mV	
Back-light Lamp Voltage	V <sub>BL</sub>	760	580	540	V <sub>rms</sub>	Note 2
Back-light Lamp Current	I <sub>BL</sub>	2.0	5.0	7.0	mA <sub>rm</sub>	
Back-light Lamp operating Frequency	F <sub>L</sub>	45	55	80	KHz	One Lamp, Note 3
Lamp Start Voltage		-	-	1120	V <sub>rms</sub>	Ta = 25°C, Note 4
		-	-	1350	V <sub>rms</sub>	Ta = 0°C, Note 4
Lamp Life		10,000	15,000	-	hrs	I <sub>BL</sub> =7.0mA, Note 5
Power Consumption		P <sub>D</sub>	1.0		W	at Windows XP,
		P <sub>BL</sub>	3.5	3.85	W	I <sub>BL</sub> = 6.0mA, Note 6
		P <sub>total</sub>	4.5		W	

- Notes : 1. The supply voltage is measured and specified at the interface connector of LCM.  
 The current draw and power consumption specified is for 3.3V at 25°C.  
 a) Typ. : Windows XP desktop Pattern      b) Max. : V2 Skip Pattern
2. Reference value, which is measured with Samsung Electric SIC-180 Inverter.  
 (VBL Min is value at IBL Min and VBL Max is value at IBL Max)
3. The lamp frequency should be selected as different as possible from the horizontal synchronous frequency and its harmonics to avoid interference which may cause line flow on the display.
4. For starting the backlight unit, the output voltage of DC/AC's transformer should be larger than the minimum lamp starting voltage. (1120 Vrms at 25 °C & 1,350 Vrms at 0 °C)  
 If an inverter has shutdown function it should keep its output for more than 1 second even if the lamp connector open. Otherwise the lamps may not to be turned on.
5. End of Life shall be determined by the time when any of the following is satisfied under continuous lighting at 25°C and IBL = 7.0mA.  
 • Intensity drops to 50% of the Initial Value.
6. Calculated value for reference (VBL × IBL)

SPEC. NUMBER  
S864-1264

SPEC. TITLE  
HT121WX2-103 Product Specification

PAGE  
7 / 27





# PRODUCT GROUP

REV

ISSUE DATE

TFT-LCD PRODUCT

D

2008.04.28

## 4.0 OPTICAL SPECIFICATION

The test of Optical specifications shall be measured in a dark room (ambient luminance  $\leq 1$  lux and temperature =  $25 \pm 2^\circ\text{C}$ ) with the equipment of Luminance meter system (Goniometer system and TOPCONE BM-5) and test unit shall be located at an approximate distance 50cm from the LCD surface at a viewing angle of  $\theta$  and  $\Phi$  equal to  $0^\circ$ . We refer to  $\theta_{\phi=0}$  ( $=\theta_3$ ) as the 3 o'clock direction (the "right"),  $\theta_{\phi=90}$  ( $=\theta_{12}$ ) as the 12 o'clock direction ("upward"),  $\theta_{\phi=180}$  ( $=\theta_9$ ) as the 9 o'clock direction ("left") and  $\theta_{\phi=270}$  ( $=\theta_6$ ) as the 6 o'clock direction ("bottom"). While scanning  $\theta$  and/or  $\phi$ , the center of the measuring spot on the Display surface shall stay fixed. The backlight should be operating for 30 minutes prior to measurement... VDD shall be  $3.3 \pm 0.3\text{V}$  at  $25^\circ\text{C}$ . Optimum viewing angle direction is 6 o'clock.

PARAMETER		SYMBOL	CONDITION	MIN.	TYP.	MAX.	UNIT	REMARK
Viewing Angle Range	Horizontal	$\theta_3$	CR > 10	40	45	-	Deg.	Note 1
		$\theta_9$		40	45	-	Deg.	
	Vertical	$\theta_{12}$		15	20	-	Deg.	
		$\theta_6$		40	45	-	Deg.	
Luminance Contrast ratio		CR	$\theta = 0^\circ$	250	300	-		Note 2
Luminance of White	1 Point	$Y_w$	$\theta = 0^\circ$ IBL = 6mA	170	200	-	cd/m <sup>2</sup>	Note 3
White Luminance Uniformity	5 Points	$\Delta Y_5$		80	85	-	%	Note 4
	13 Points	$\Delta Y_{13}$		65	75	-		
White Chromaticity		$x_w$	$\theta = 0^\circ$	0.283	0.313	0.343		Note 5
		$y_w$		0.299	0.329	0.359		
Reproduction of Color	Red	$x_R$	$\theta = 0^\circ$	0.559	0.589	0.619		
		$y_R$		0.301	0.331	0.361		
	Green	$x_G$		0.273	0.303	0.333		
		$y_G$		0.510	0.540	0.570		
	Blue	$x_B$		0.117	0.147	0.177		
		$y_B$		0.115	0.145	0.175		
Response Time	$T_r + T_d$		Ta = $25^\circ\text{C}$ $\theta = 0^\circ$		10	22.5	ms	Note 6
	$T_d$				15	27.5	ms	
Cross Talk		CT	$\theta = 0^\circ$			2.0	%	Note 7

SPEC. NUMBER  
S864-1264

SPEC. TITLE  
HT121WX2-103 Product Specification

PAGE  
8 / 27



# PRODUCT GROUP

REV

ISSUE DATE

TFT-LCD PRODUCT

D

2008.04.28

- Note :
1. Viewing angle is the angle at which the contrast ratio is greater than 10. The viewing are determined for the horizontal or 3, 9 o'clock direction and the vertical or 6, 12 o'clock direction with respect to the optical axis which is normal to the LCD surface . (see FIGURE 1)
  2. Contrast measurements shall be made at viewing angle of  $\Theta = 0^\circ$  and at the center of the LCD surface. Luminance shall be measured with all pixels in the view field set first to white, then to the dark (black) state. (See FIGURE 1)  
Luminance Contrast Ratio (CR) is defined mathematically.

$$CR = \frac{\text{Luminance when displaying a white raster}}{\text{Luminance when displaying a black raster}}$$

3. Luminance of white is defined as a center point (1) on LCD surface. Luminance shall be measured with all pixels in the view field set first to white. This measurement shall be taken at the locations shown in FIGURE 2 for a total of the measurements per display.
4. The White luminance uniformity on LCD surface is then expressed. (See FIGURE 2)

$$\text{Uniformity } \Delta Y = \frac{\text{Minimum Luminance of 5(or 13) points}}{\text{Maximum Luminance of 5(or 13) points}} \times 100 (\%)$$

5. The color chromaticity coordinates specified in Table 4 shall be calculated from the spectral data measured with all pixels first in red, green, blue and white. Measurements shall be made at the center of the panel.
6. The electro-optical response time measurements shall be made as FIGURE 3 by switching the "data" input signal OFF and ON. The times needed for the luminance to change from 10% to 90% is  $T_r$ , and 90% to 10% is  $T_d$ .
7. Cross-Talk of one area of the LCD surface by another shall be measured by comparing the luminance (YA) of a 25mm diameter area, with all display pixels set to a gray level, to the luminance (YB) of that same area when any adjacent area is driven dark. (See FIGURE 4 ).

SPEC. NUMBER  
S864-1264

SPEC. TITLE  
HT121WX2-103 Product Specification

PAGE  
9 / 27



# PRODUCT GROUP

REV

ISSUE DATE

TFT-LCD PRODUCT

D

2008.04.28

Figure 1. Measurement Set Up

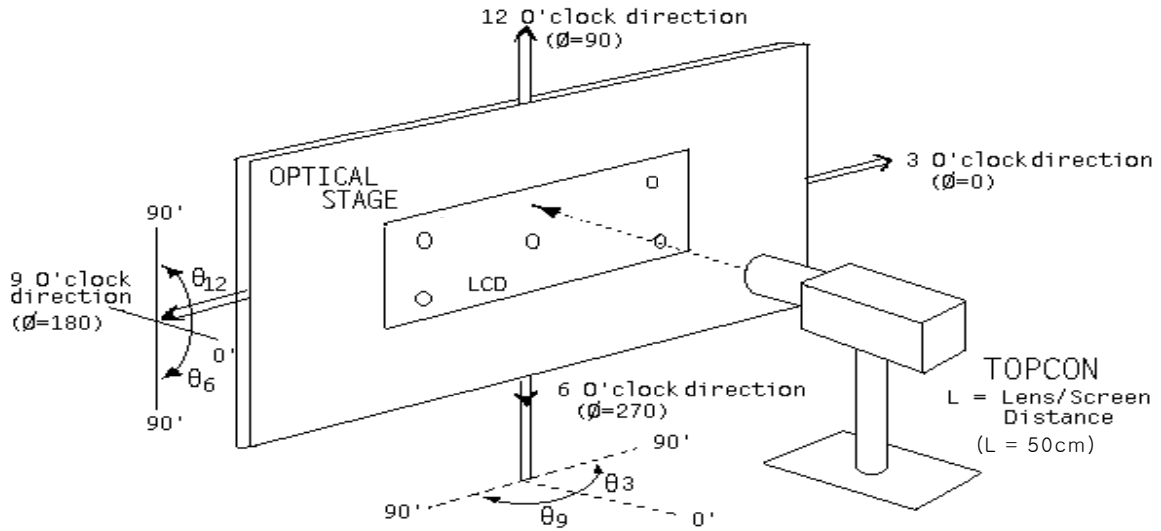
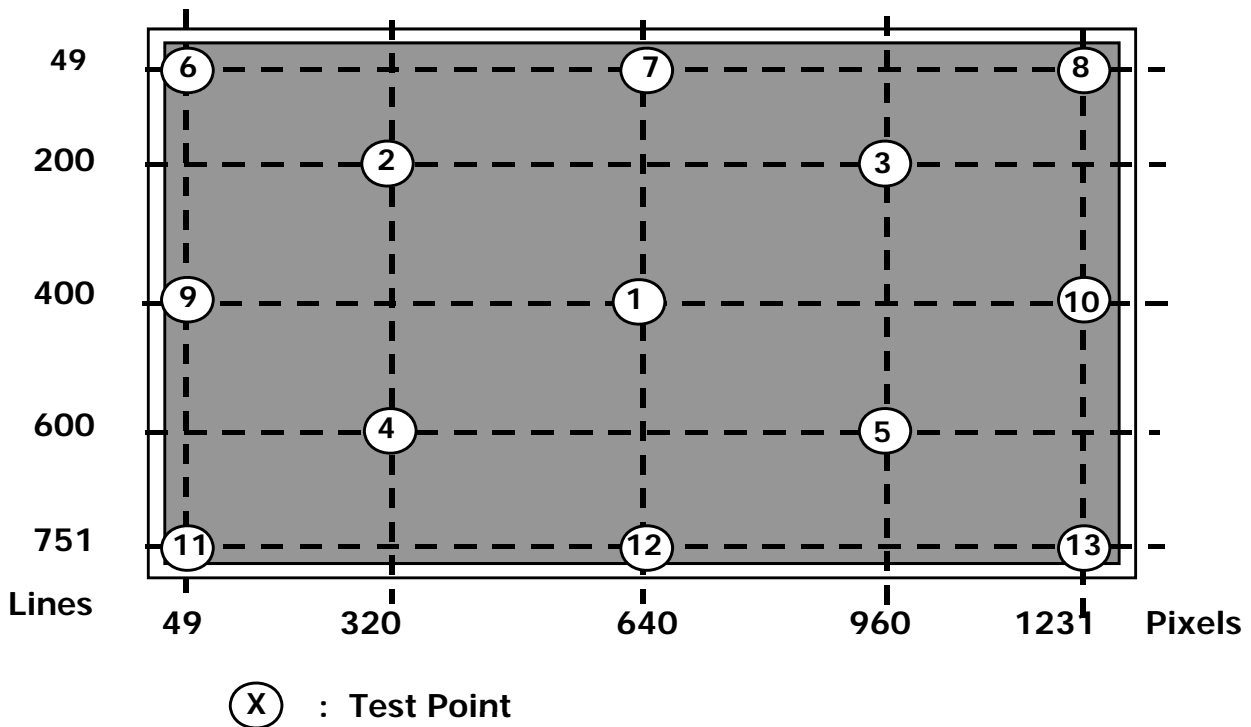

Figure 2. Average Luminance Measurement Locations & Uniformity Measurement Locations



SPEC. NUMBER  
S864-1264

SPEC. TITLE  
HT121WX2-103 Product Specification

PAGE  
10 / 27



# PRODUCT GROUP

REV

ISSUE DATE

TFT-LCD PRODUCT

D

2008.04.28

Figure 3. Response Time Testing

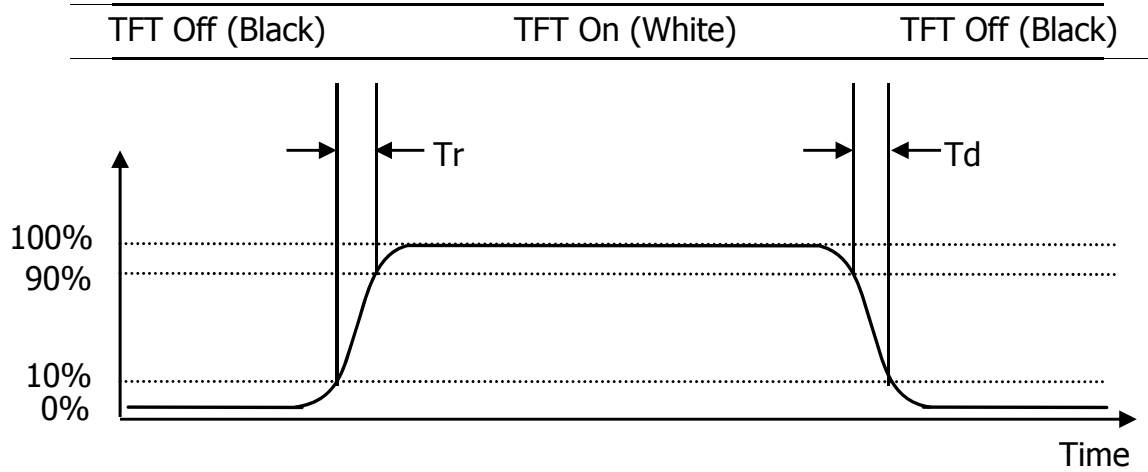
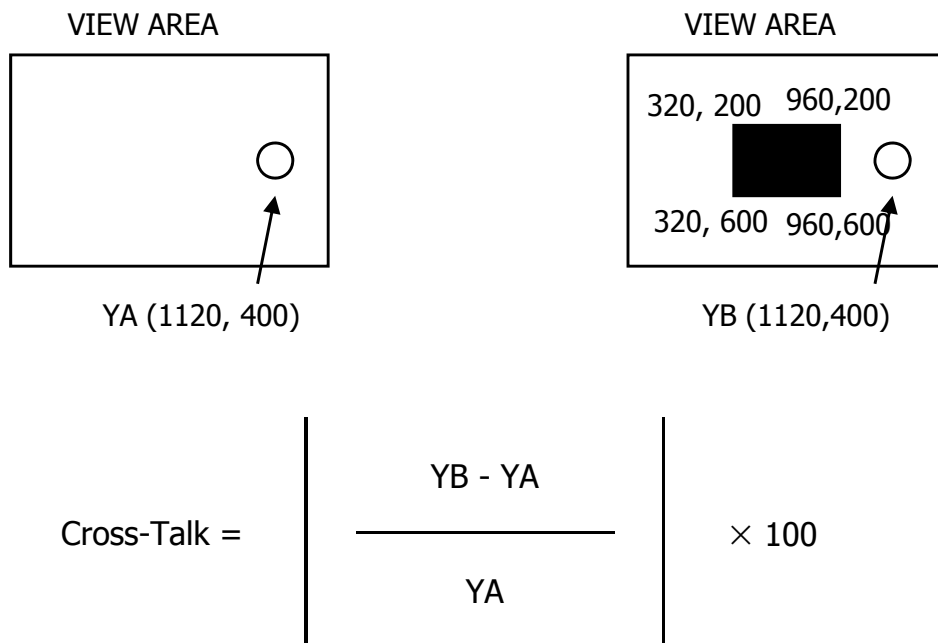

Figure 4. Cross Modulation Test Description



Where:  $Y_A$  = Initial luminance of measured area ( $cd/m^2$ )

$Y_B$  = Subsequent luminance of measured area ( $cd/m^2$ )

The location measured will be exactly the same in both patterns.

SPEC. NUMBER  
S864-1264

SPEC. TITLE  
HT121WX2-103 Product Specification

PAGE  
11 / 27



# PRODUCT GROUP

REV

ISSUE DATE

TFT-LCD PRODUCT

D

2008.04.28

## 5.0 INTERFACE CONNECTION

### 5.1 Electrical Interface

CN1	Interface Connector	DF19L-14P-1H (HIROSE) or equivalent
	User side Connector	DF19G-14S-1C (HIROSE) or equivalent

PIN NO.	SYMBOL	FUNCTION	REMARK
1	VSS	Ground	
2	VDD1	Power Supply: +3.3V	
3	VDD2	Power Supply: +3.3V	
4	Vdd_EDID	EDID +3.3V	
5	NC	Reserved	
6	Clk_EDID	EDID Clk	
7	Clk_Data	EDID Data	
8	RIN0-	LVDS Negative data signal (-)	Tx pin # 48
9	RIN0+	LVDS Positive data signal (+)	Tx pin # 47
10	VSS	Ground	Tx pin # 46
11	RIN1-	LVDS Negative data signal (-)	Tx pin # 45
12	RIN1+	LVDS Positive data signal (+)	Tx pin # 42
13	VSS	Ground	Tx pin # 41
14	RIN2-	LVDS Negative data signal (-)	Tx pin # 40
15	RIN2+	LVDS Positive data signal (+)	Tx pin # 39
16	VSS	Ground	
17	RCLKIN-	LVDS Negative clock signal (-)	
18	RCLKIN+	LVDS Positive clock signal (+)	
19	VSS	Ground	
20	VSS	Ground	

### 5.2 Back-light Interface

CN2	Interface Connector	BHSR-02VS-1 (JST) or equivalent
	User side Connector	SM02B-BHSS-1 (JST) or equivalent

PIN NO.	INPUT	FUNCTION	REMARK
1	HOT	High voltage	Pink
2	COLD	Ground	Black

SPEC. NUMBER  
S864-1264

SPEC. TITLE  
HT121WX2-103 Product Specification

PAGE  
12 / 27



# PRODUCT GROUP

REV

ISSUE DATE

TFT-LCD PRODUCT

D

2008.04.28

## 5.3 LVDS Interface

LVDS Transmitter : THC63LVDM83A or equivalent

INPUT SIGNAL	TRANSMITTER		INTERFACE		DF19KR-20P-1H	REMARK
	PIN NO.	PIN NO.	SYSTEM (Tx)	TFT-LCD (Rx)	PIN NO.	
R0	51	48 47	OUT0- OUT0+	IN0- IN0+	5 6	
R1	52					
R2	54					
R3	55					
R4	56					
R5	3					
G0	4	46 45	OUT1- OUT1+	IN1- IN1+	8 9	
G1	6					
G2	7					
G3	11					
G4	12					
G5	14					
B0	15	42 41	OUT2- OUT2+	IN2- IN2+	11 12	
B1	19					
B2	20					
B3	22					
B4	23					
B5	24					
HSYNC	27	40	CLKOUT-	CLKIN-	14	
VSYNC	28					
DE	30	39	CLKOUT+	CLKIN+	15	
MCLK	31					

## 5.4 Data Input Format

Display position of input data

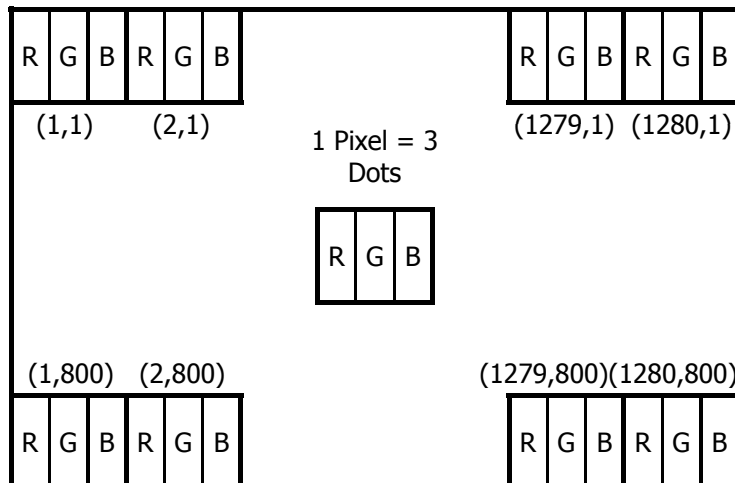

SPEC. NUMBER  
S864-1264

SPEC. TITLE  
HT121WX2-103 Product Specification

PAGE  
13 / 27



# PRODUCT GROUP

REV

ISSUE DATE

TFT-LCD PRODUCT

D

2008.04.28

## 6.0 SIGNAL TIMING SPECIFICATION

### 6.1 LVDS Transmitter Input

The 12.1" WXGA LCM is operated by the only DE (Data enable) mode.

ITEM	SYMBOL	MIN	TYP	MAX	UNIT
Frame Period	T1	804	823	-	lines
Vertical Display Period	T2	-	800	-	lines
One Line Scanning Period	T3	1350	1440	-	clocks
Horizontal Display Period	T4	-	1280	-	clocks
Clock Frequency	1/T5	-	71.11	-	MHz

### 6.2 LVDS Rx Interface Timing Parameter

ITEM	SYMBOL	MIN	TYP	MAX	UNIT	REMARK
CLKIN Period	tRCIP	12.5	14.06	25.00	nsec	
Input Data 0	tRIP0	-0.4	0.0	+0.4	nsec	
Input Data 1	tRIP1	tRCIP/7-0.4	tRCIP/7	tRCIP/7+0.4	nsec	
Input Data 2	tRIP2	2 × tRCIP/7-0.4	2 × tRCIP/7	2 × tRCIP/7+0.4	nsec	
Input Data 3	tRIP3	3 × tRCIP/7-0.4	3 × tRCIP/7	3 × tRCIP/7+0.4	nsec	
Input Data 4	tRIP4	4 × tRCIP/7-0.4	4 × tRCIP/7	4 × tRCIP/7+0.4	nsec	
Input Data 5	tRIP5	5 × tRCIP/7-0.4	5 × tRCIP/7	5 × tRCIP/7+0.4	nsec	
Input Data 6	tRIP6	6 × tRCIP/7-0.4	6 × tRCIP/7	6 × tRCIP/7+0.4	nsec	

\* Vdiff = (RINz+)-(RINz-), (RCLKIN+)-(RCLKIN-)

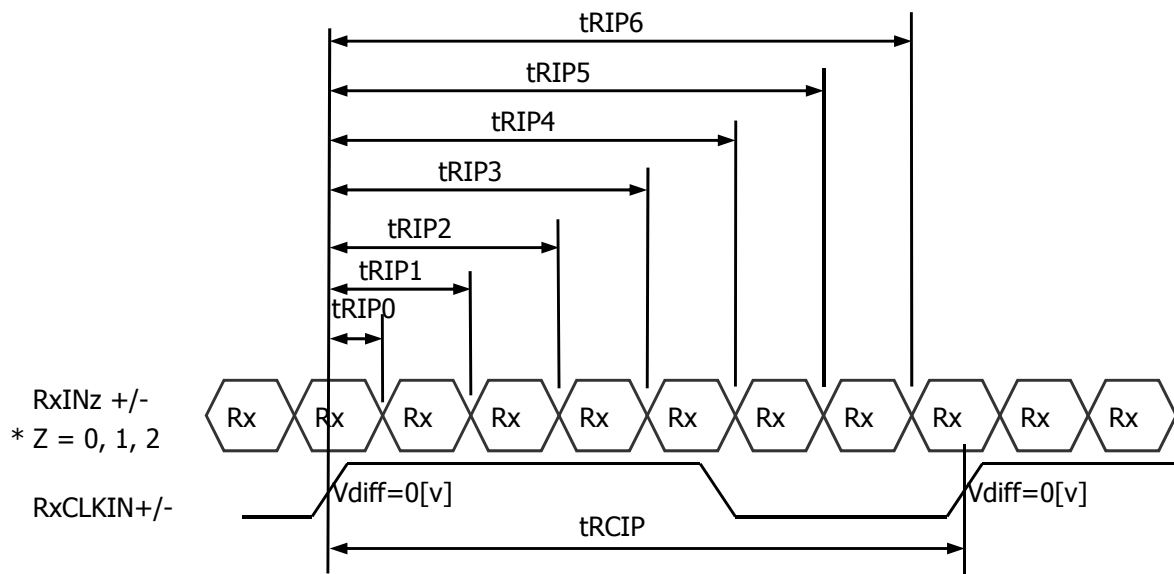

SPEC. NUMBER  
S864-1264

SPEC. TITLE  
HT121WX2-103 Product Specification

PAGE  
14 / 27



PRODUCT GROUP

REV

ISSUE DATE

TFT-LCD PRODUCT

D

2008.04.28

## 7.0 SIGNAL TIMING WAVEFORMS OF INTERFACE SIGNAL (DE MODE)

### 7.1 Timing Waveforms of Interface Signal

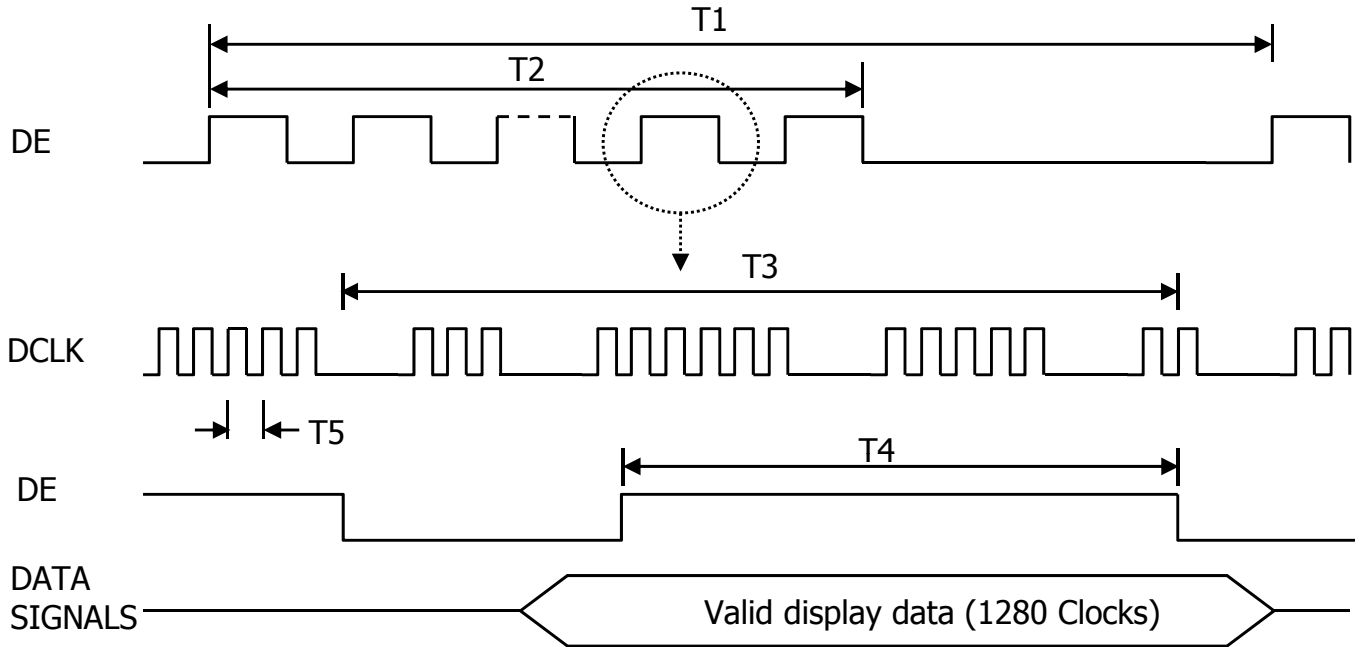

SPEC. NUMBER  
S864-1264

SPEC. TITLE  
HT121WX2-103 Product Specification

PAGE  
15 / 27





# PRODUCT GROUP

REV

ISSUE DATE

TFT-LCD PRODUCT

D

2008.04.28

## 8.0 INPUT SIGNALS, BASIC DISPLAY COLORS & GRAY SCALE OF COLORS

Each color is displayed in sixty-four gray scales from a 6 bit data signal input. A total of 262,144 colors are derived from the resultant 18 bit data.

Colors & Gray Scale		Red Data						Green Data						Blue Data					
		R5	R4	R3	R2	R1	R0	G5	G4	G3	G2	G1	G0	B5	B4	B3	B2	B1	B0
Basic Colors	Black	0	0	0	0	0	0	0	0	0	0	0	0	0	0	0	0	0	0
	Blue	0	0	0	0	0	0	0	0	0	0	0	0	1	1	1	1	1	1
	Green	0	0	0	0	0	0	1	1	1	1	1	1	0	0	0	0	0	0
	Cyan	0	0	0	0	0	0	1	1	1	1	1	1	1	1	1	1	1	1
	Red	1	1	1	1	1	1	0	0	0	0	0	0	0	0	0	0	0	0
	Magenta	1	1	1	1	1	1	0	0	0	0	0	0	1	1	1	1	1	1
	Yellow	1	1	1	1	1	1	1	1	1	1	1	1	0	0	0	0	0	0
	White	1	1	1	1	1	1	1	1	1	1	1	1	1	1	1	1	1	1
Gray Scale Of Red	Black	0	0	0	0	0	0	0	0	0	0	0	0	0	0	0	0	0	0
	△	0	0	0	0	0	1	0	0	0	0	0	0	0	0	0	0	0	0
	Darker	0	0	0	0	1	0	0	0	0	0	0	0	0	0	0	0	0	0
	△	↓						↓						↓					
	▽	↓						↓						↓					
	Brighter	1	1	1	1	0	1	0	0	0	0	0	0	0	0	0	0	0	0
	▽	1	1	1	1	1	0	0	0	0	0	0	0	0	0	0	0	0	0
	Red	1	1	1	1	1	1	0	0	0	0	0	0	0	0	0	0	0	0
Gray Scale Of Green	Black	0	0	0	0	0	0	0	0	0	0	0	0	0	0	0	0	0	0
	△	0	0	0	0	0	0	0	0	0	0	0	1	0	0	0	0	0	0
	Darker	0	0	0	0	0	0	0	0	0	0	1	0	0	0	0	0	0	0
	△	↓						↓						↓					
	▽	↓						↓						↓					
	Brighter	0	0	0	0	0	0	1	1	1	1	0	1	0	0	0	0	0	0
	▽	0	0	0	0	0	0	1	1	1	1	1	0	0	0	0	0	0	0
	Green	0	0	0	0	0	0	1	1	1	1	1	1	0	0	0	0	0	0
Gray Scale Of Blue	Black	0	0	0	0	0	0	0	0	0	0	0	0	0	0	0	0	0	0
	△	0	0	0	0	0	0	0	0	0	0	0	0	0	0	0	0	0	1
	Darker	0	0	0	0	0	0	0	0	0	0	0	0	0	0	0	0	1	0
	△	↓						↓						↓					
	▽	↓						↓						↓					
	Brighter	0	0	0	0	0	0	0	0	0	0	0	0	1	1	1	1	0	1
	▽	0	0	0	0	0	0	0	0	0	0	0	0	1	1	1	1	1	0
	Blue	0	0	0	0	0	0	0	0	0	0	0	0	1	1	1	1	1	1
Gray Scale Of White & Black	Black	0	0	0	0	0	0	0	0	0	0	0	0	0	0	0	0	0	0
	△	0	0	0	0	0	1	0	0	0	0	0	1	0	0	0	0	0	1
	Darker	0	0	0	0	1	0	0	0	0	0	1	0	0	0	0	0	1	0
	△	↓						↓						↓					
	▽	↓						↓						↓					
	Brighter	1	1	1	1	0	1	1	1	1	1	0	1	1	1	1	1	0	1
	▽	1	1	1	1	1	0	1	1	1	1	1	0	1	1	1	1	1	0

SPEC. NUMBER  
S864-1264

SPEC. TITLE  
HT121WX2-103 Product Specification

PAGE  
16 / 27



# PRODUCT GROUP

REV

ISSUE DATE

TFT-LCD PRODUCT

D

2008.04.28

## 9.0 POWER SEQUENCE

To prevent a latch-up or DC operation of the LCD module, the power on/off sequence shall be as shown in below

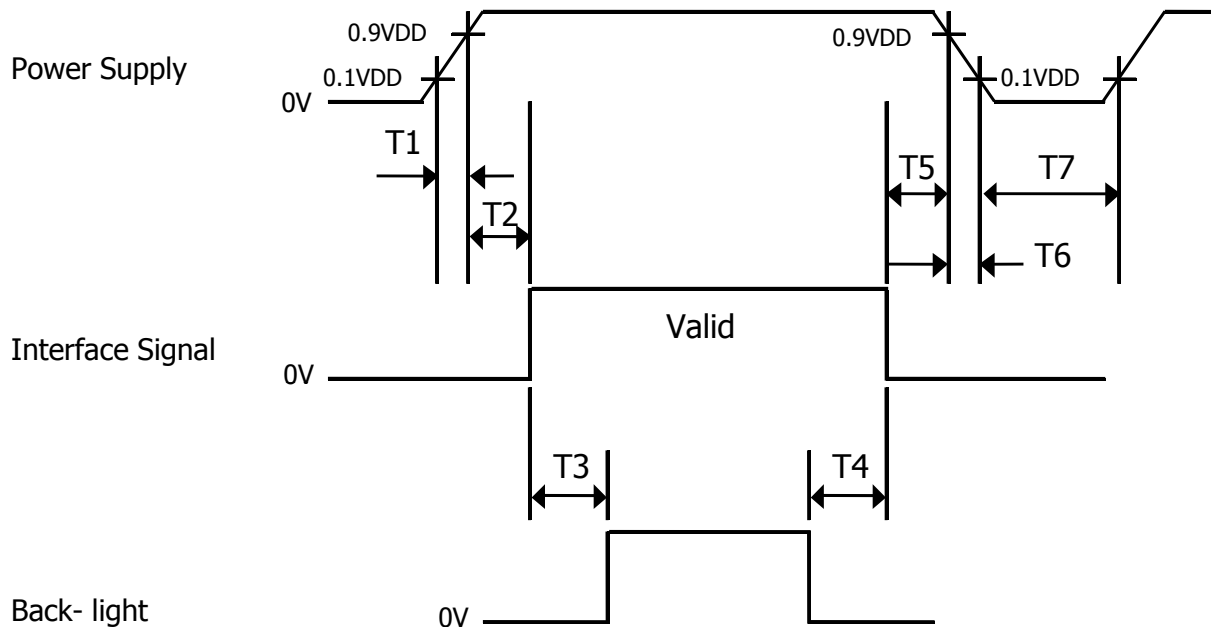

- 1)  $0 < T1 \leq 10 \text{ ms}$
- 2)  $0 < T2 \leq 50 \text{ ms}$
- 3)  $200 \text{ ms} \leq T3$
- 4)  $200 \text{ ms} \leq T4$
- 5)  $0 \leq T5 \leq 50 \text{ ms}$
- 6)  $0 \leq T6 \leq 10 \text{ ms}$
- 7)  $150 \text{ ms} \leq T7$

- Notes :
1. When the power supply VDD is 0V, Keep the level of input signals on the low or keep high impedance.
  2. Do not keep the interface signal high impedance when power is on.
  3. Back Light must be turn on after power for logic and interface signal are valid.

SPEC. NUMBER  
S864-1264

SPEC. TITLE  
HT121WX2-103 Product Specification

PAGE  
17 / 27



# PRODUCT GROUP

REV

ISSUE DATE

TFT-LCD PRODUCT

D

2008.04.28

## 10.0 MECHANICAL CHARACTERISTICS

### 10.1 Dimensional Requirements

FIGURE 5, 6 shown in appendix shows mechanical outlines for the model.

PARAMETER	SPECIFICATION	UNIT
Active area	261.12 (H) × 163.20 (V)	mm
Number of pixels	1280 (H) × 800 (V) (1 pixel = R + G + B dots)	pixels
Pixel pitch	0.2055 (H) × 0.2055 (V)	mm
Pixel arrangement	RGB Vertical stripe	
Display colors	262,144	colors
Display mode	Normally White	
Dimensional outline	275.8±0.5(W) x 178.0±0.5(V) x 4.9Typ.(D) (5.2Max)	mm
Weight	260 Typ. / 270 Max.	g
Back-light	CCFL, horizontal-lamp type	

### 10.2 Mounting

See FIGURE 5. (shown in Appendix)

### 10.3 Glare Polarizer

The surface of the LCD has an glare coating.

### 10.4 Light Leakage

There shall not be visible light from the back-lighting system around the edges of the screen as seen from a distance 50 cm from the screen with an overhead light level of 150lux. The manufacture shall furnish limit samples of the panel showing the light leakage acceptable.

SPEC. NUMBER  
S864-1264

SPEC. TITLE  
HT121WX2-103 Product Specification

PAGE  
18 / 27



# PRODUCT GROUP

REV

ISSUE DATE

TFT-LCD PRODUCT

D

2008.04.28

## 11.0 RELIABILITY TEST

NO	TEST ITEM	CONDITIONS
1	High temperature storage test	Ta = 60 °C, 240 hrs
2	Low temperature storage test	Ta = -20 °C, 240 hrs
3	High temperature & high humidity operation test	Ta = 50 °C, 80%RH, 240hrs
4	High temperature operation test	Ta = 50 °C, 240 hrs
5	Low temperature operation test	Ta = 0 °C, 240 hrs
6	Thermal shock	Ta = -20 °C ↔ 60 °C (30 min), 100 cycle
7	Vibration test (non-operating)	Frequency : 10~500Hz Gravity/AMP : 1.5G Period : X,Y,Z 30min
8	Shock test (non-operating)	Gravity : 220G Pulse width : 2ms, half sine wave ±X, ±Y, ±Z Once for each direction
9	Electro-Static Discharge Test (non-operating)	Air : 150pF, 330ohm, 15KV Contact : 150pF, 330ohm, 8KV

SPEC. NUMBER  
S864-1264

SPEC. TITLE  
HT121WX2-103 Product Specification

PAGE  
19 / 27



## PRODUCT GROUP

REV

ISSUE DATE

TFT-LCD PRODUCT

D

2008.04.28

### 12.0 HANDLING & CAUTIONS

#### 12.1 Cautions when taking out the module

- 1) Pick the pouch only, when taking out module from a shipping package.

#### 12.2 Cautions for handling the module

- 1) As the electrostatic discharges may break the LCD module, handle the LCD module with care. Peel a protection sheet off from the LCD panel surface as slowly as possible.
- 2) As the LCD panel and backlight element are made from fragile glass material, impulse and pressure to the LCD module should be avoided.
- 3) As the surface of the polarizer is very soft and easily scratched, use a soft dry cloth without chemicals for cleaning.
- 4) Do not pull the interface connector in or out while the LCD module is operating.
- 5) Put the module display side down on a flat horizontal plane.
- 6) Handle connectors and cables with care.

#### 12.3 Cautions for the operation

- 1) When the module is operating, do not lose MCLK, DE signals. If any one of these signals were lost, the LCD panel would be damaged.
- 2) Obey the supply voltage sequence. If wrong sequence were applied, the module would be damaged.

#### 12.4 Cautions for the atmosphere

- 1) Dewdrop atmosphere should be avoided.
- 2) Do not store and/or operate the LCD module in a high temperature and/or humidity atmosphere. Storage in an electro-conductive polymer-packing pouch and under relatively low temperature atmosphere is recommended.

#### 12.5 Cautions for the module characteristics

- 1) Do not apply fixed pattern data signal to the LCD module at product aging.
- 2) Applying fixed pattern for a long time may cause image sticking.

#### 12.6 Other cautions

- 1) Do not disassemble and/or re-assemble LCD module.
- 2) Do not re-adjust variable resistor or switch etc.
- 3) When returning the module for repair or etc, please pack the module not to be broken.
- 4) We recommend using the original shipping packages.

SPEC. NUMBER  
S864-1264

SPEC. TITLE  
HT121WX2-103 Product Specification

PAGE  
20 / 27



# PRODUCT GROUP

REV

ISSUE DATE

TFT-LCD PRODUCT

D

2008.04.28

## 13.0 PACKING

### 13.1 Packing Order

- Notes : 1. Box Dimension: 261mm(W) X 349mm(D) X 311mm(H)
- 2. Package Quantity in one Box: 10pcs

Put Pad into the box.

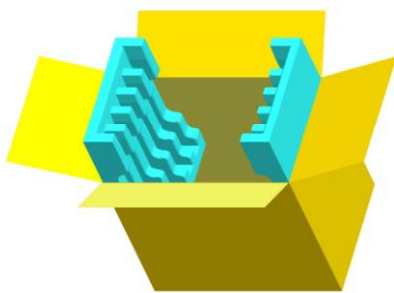

Put silica gels in the box.

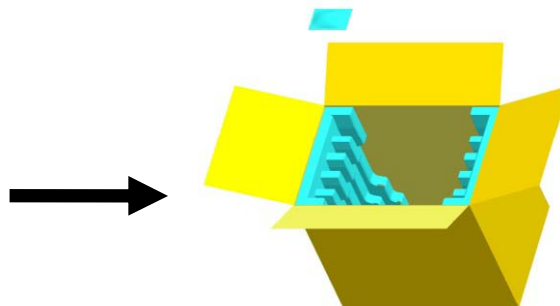

After sealing the box, attach Packing Label on the attach position sign area of the box.

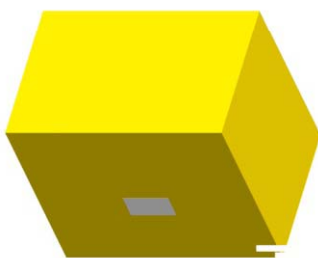

Place a cover on the top of the box.

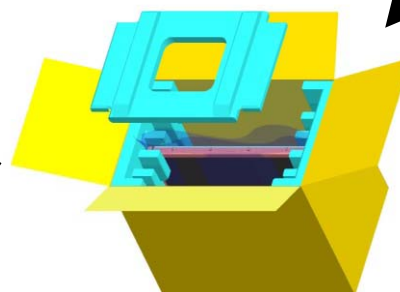

As shown in the figure, place the Modules bundled by shielding bag in the box.



SPEC. NUMBER  
S864-1264

SPEC. TITLE  
HT121WX2-103 Product Specification

PAGE  
21 / 27



# PRODUCT GROUP

REV

ISSUE DATE

TFT-LCD PRODUCT

D

2008.04.28

## 14.0 Environment & Safety

### 14.1 Packing Label

1) Label Size: 108 mm (L) × 56 mm (W)

2) Contents

Model : HT121WX2-103

Q`ty : Module Q`ty in one box

Serial No. : Box Serial No. See next figure for detail description.

Date : Packing Date

FG Code : FG Code of Product

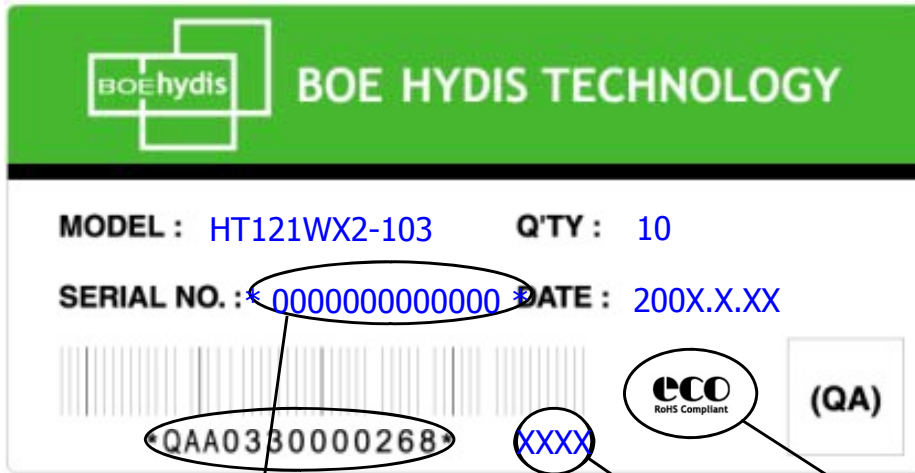

<u>00</u>	<u>0</u>	<u>00</u>	<u>0</u>	<u>0</u>	<u>000000</u>
Type	Grade	Year	Month	ITEM-CODE	Serial_no

FG CODE

RoHS Mark

### 14.2 Mercury disposal & High voltage caution

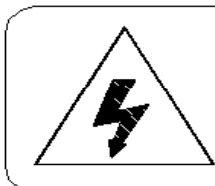

**HIGH VOLTAGE CAUTION**

RISK OF ELECTRIC SHOCK. DISCONNECT THE ELECTRIC POWER BEFORE SERVICING

COLD CATHODE FLUORESCENT LAMP IN LCD PANEL CONTAINS A SMALL AMOUNT OF MERCURY. PLEASE FOLLOW LOCAL ORDINANCES OR REGULATIONS FOR DISPOSAL.

SPEC. NUMBER  
S864-1264

SPEC. TITLE  
HT121WX2-103 Product Specification

PAGE  
22 / 27



# PRODUCT GROUP

REV

ISSUE DATE

TFT-LCD PRODUCT

D

2008.04.28

## 14.3 Product Label

### 1) Picture



Barcode

### 2) BOE HYDIS Barcode

No 1. Control Number

No 2. Rank / Grade

No 3. Line Classification (BOE HYDIS : H, LCM : L, BOE OT : A/B/C)

No 4. Year (5 : 2005, 6 : 2006, ...)

No 5. Month (1, 2, 3, ..., 9, X, Y, Z)

No 6. FG Code

No 7. Serial Number

SPEC. NUMBER  
S864-1264

SPEC. TITLE  
HT121WX2-103 Product Specification

PAGE  
23 / 27





PRODUCT GROUP

REV

ISSUE DATE

TFT-LCD PRODUCT

D

2008.04.28

### 15.0 TFT-LCD Module Outline Dimensions

#### 15.1 Font View

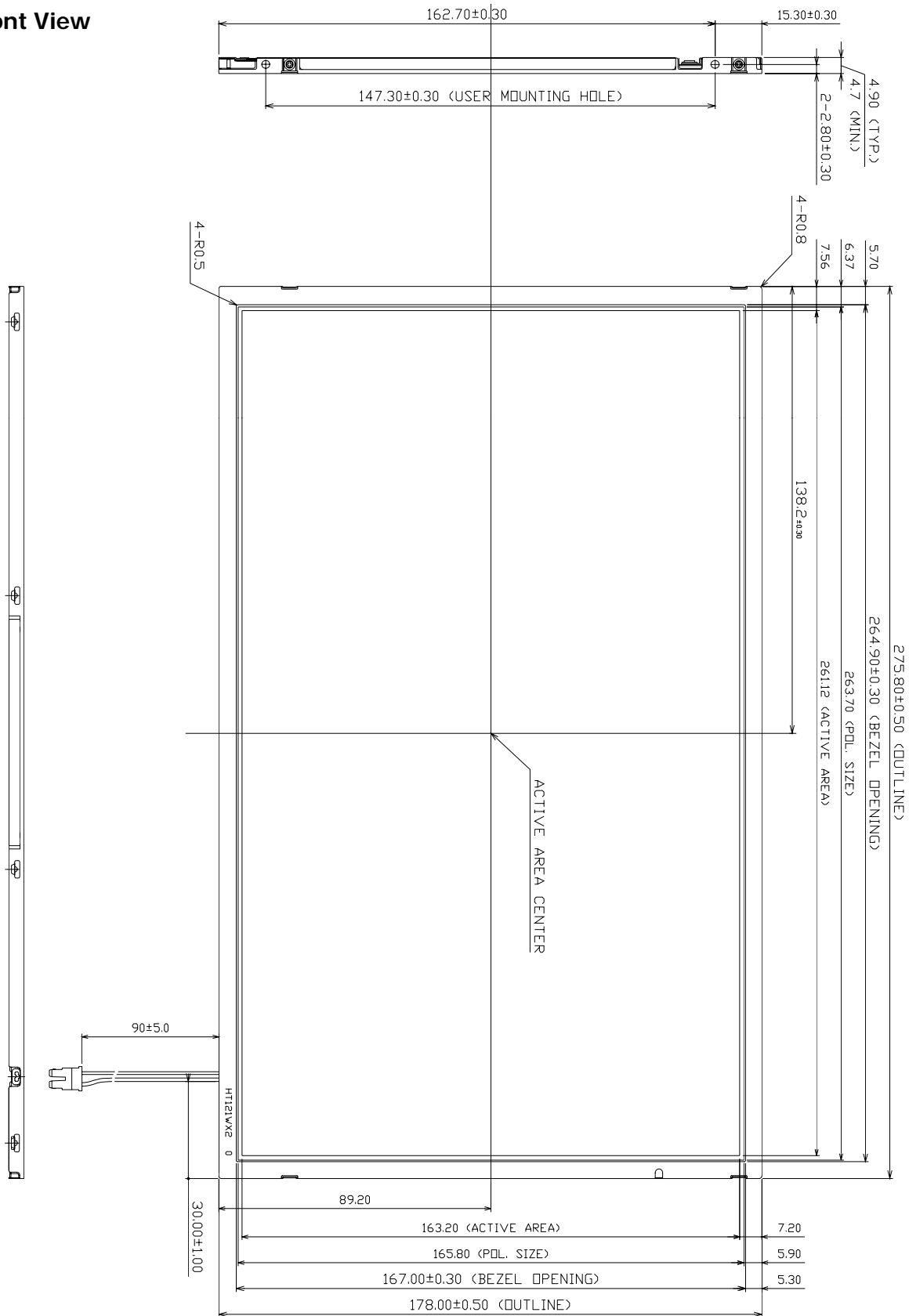

SPEC. NUMBER  
S864-1264

SPEC. TITLE  
HT121WX2-103 Product Specification

PAGE  
24 / 27



# PRODUCT GROUP

REV

ISSUE DATE

## TFT-LCD PRODUCT

D

2008.04.28

### 15.0 TFT-LCD Module Outline Dimensions

#### 15.1 Rear View

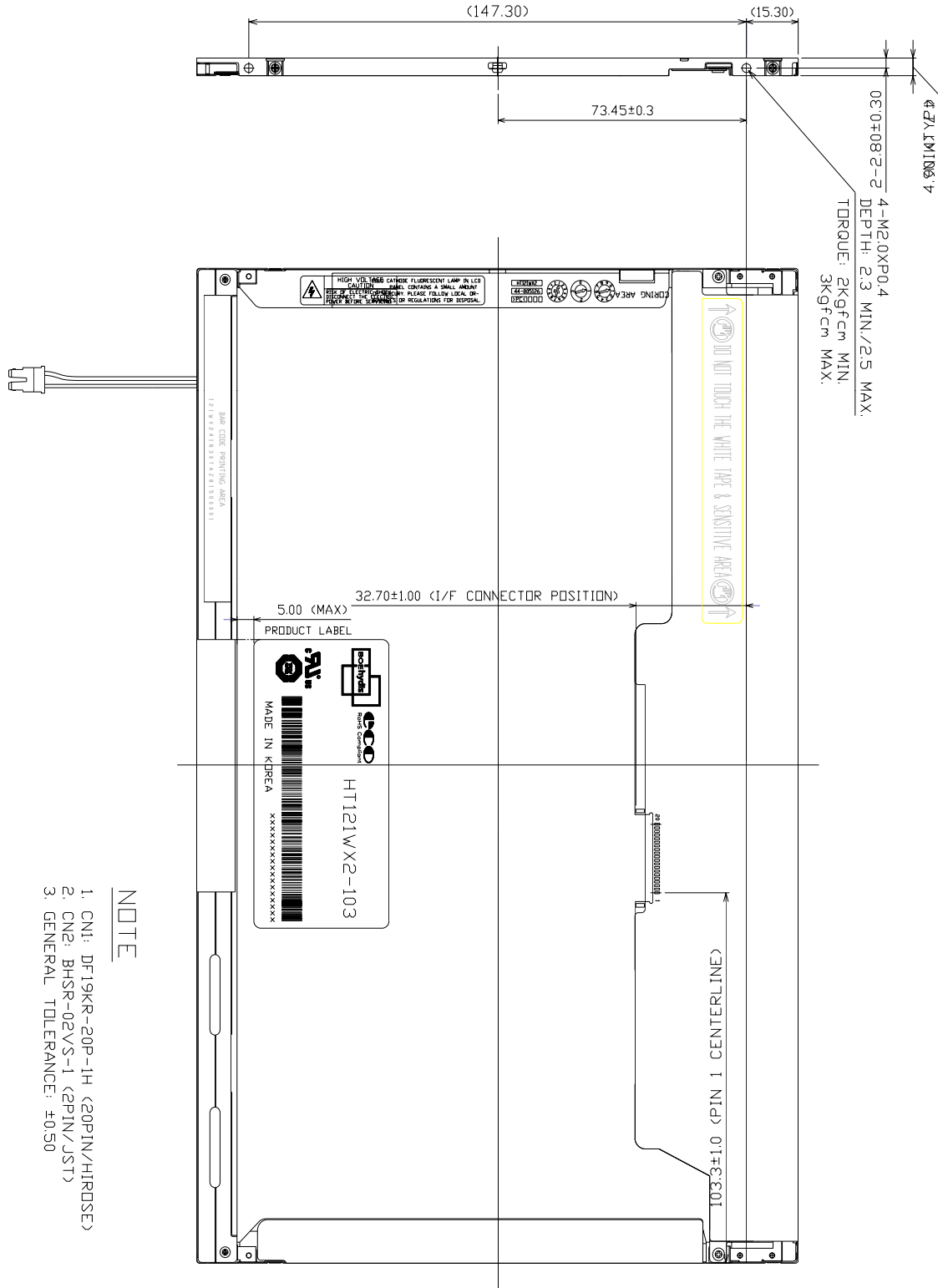

#### NOTE

1. CNI: DF19KR-20P-1H (20PIN/HIRDSE)
2. CNG: BHSR-02VS-1 (2PIN/JST)
3. GENERAL TOLERANCE: ±0.50

SPEC. NUMBER  
S864-1264

SPEC. TITLE  
HT121WX2-103 Product Specification

PAGE  
25 / 27



# PRODUCT GROUP

REV

ISSUE DATE

TFT-LCD PRODUCT

D

2008.04.28

## 15.0 EDID Data

Add	Function	Hex	Input Value	Add	Function	Hex	Input Value
00	Header	00	EDID	20	Blue y high bits	25	0.145
01		FF		21	White x high bits	50	0.313
02		FF		22	White y high bits	54	0.329
03		FF		23	Established timing 1	00	
04		FF		24	Established timing 2	00	
05		FF		25	Established timing 3	00	
06		FF		26	Standard timing #1	01	Not Used
07		00		27		01	
08	ID Manufacturer Name	09		28	Standard timing #2	01	Not Used
09		E5		29		01	
0A	ID Product Code	B3	1203	2A	Standard timing #3	01	Not Used
0B		04		2B		01	
0C	32-bit serial No.	00		2C	Standard timing #4	01	Not Used
0D		00		2D		01	
0E		00		2E	Standard timing #5	01	Not Used
0F		00		2F		01	
10	Week of manufacture	00	0	30	Standard timing #6	01	Not Used
11	Year of Manufacture	0F	2005	31		01	
12	EDID Structure Ver.	01	1	32	Standard timing #7	01	Not Used
13	EDID revision #	03	3	33		01	
14	Video input definition	80		34	Standard timing #8	01	Not Used
15	Max H image size	1A	26	35		01	
16	Max V image size	10	16	36	Detailed timing / monitor descriptor #1	C6	. Main clock : 71.1MHz . Hor. Active : 1280 . Hor. Blanking : 160 . 4 bits of Hor. Active + . 4 bits of Hor. Blanking . Ver. Active : 800 . Ver. Blanking : 23 . 4 bits of Ver. Active + . 4 bits of Ver. Blanking . Hor. Sync Offset : 48 . H sync Pulse Width : 32 . V sync Offset : 3 line . V Sync Pulse width : 6 line
17	Display Gamma	78	2.2	37		1B	
18	Feature support	0A	RGB mode	38		00	
19	Red/Green low bits	E8		39		A0	
1A	Blue/White low bits	80		3A		50	
1B	Red x high bits	96	0.589	3B		20	
1C	Red y high bits	54	0.331	3C		17	
1D	Green x high bits	4D	0.303	3D		30	
1E	Green y high bits	8A	0.540	3E	30		
1F	Blue x high bits	25	0.147	3F	20		

SPEC. NUMBER  
S864-1264

SPEC. TITLE  
HT121WX2-103 Product Specification

PAGE  
26 / 27



# PRODUCT GROUP

REV

ISSUE DATE

TFT-LCD PRODUCT

D

2008.04.28

Add	Function	Hex	Input Value	Add	Function	Hex	Input Value				
40	Detailed timing / monitor descriptor #1	36	Horizontal Image Size : 261 mm (Low 8 bits) Vertical Image Size : 163 mm (Low 8 bits) 4 bits of Hor. Image Size + 4 bits of Ver. Image Size Hor. Border : 0 pixel Vertical Border : 0 line	60	Detailed timing / monitor descriptor #3	4F	Company name : HYDIS				
41		00		61		45					
42		05		62		20					
43		A3		63		48					
44		10		64		59					
45		00		65		44					
46		00		66		49					
47		19		67		53					
48	Detailed timing / monitor descriptor #2	00		68	Detailed timing / monitor descriptor #4	0A	Model name : HT121WX2-102				
49		00		69		20					
4A		00		6A		20					
4B		FE		6B		20					
4C		00		6C		00					
4D		0A		6D		00					
4E		20		6E		00					
4F		20		6F		FE					
50		20		70		00					
51		20		71		48					
52		20		72		54					
53		20		73		31					
54		20		74		32					
55		20		75		31					
56		20		76		57					
57	20	77	58								
58	20	78	32								
59	20	79	2D								
5A	Detailed timing / monitor descriptor #3	00		7A		31					
5B		00		7B		30					
5C		00		7C		33					
5D		FE		7D		0A					
5E		00		7E		00					
5F				42				Extension flag		00	
								Checksum		2B	

SPEC. NUMBER  
S864-1264

SPEC. TITLE  
HT121WX2-103 Product Specification

PAGE  
27 / 27