

# TOSHIBA MOS MEMORY PRODUCTS

8,192 WORD × 8 BIT UV ERASABLE AND  
ELECTRICALLY PROGRAMMABLE READ ONLY MEMORY

TMM2764AD-15, TMM2764AD-150  
TMM2764AD-20, TMM2764AD-200

## DESCRIPTION

The TMM2764AD is a 8192 word × 8 bit ultraviolet light erasable and electrically programmable read only memory. For read operation, the TMM2764AD's access time is 150ns/200ns, and the TMM2764AD operates from a single 5-volt power supply and has a low power standby mode which reduces the power dissipation without increasing access time.

The standby mode is achieved by applying a TTL-high level signal to the  $\overline{CE}$  input.

For program operation, the programming is achieved by using the high speed programming mode.

The TMM2764AD is fabricated with the N-channel silicon double layer gate MOS technology.

## FEATURES

	-15	-20	-150	-200
V <sub>CC</sub>	5V ± 5%		5V ± 10%	
t <sub>ACC</sub>	150ns	200ns	150ns	200ns
I <sub>CC2</sub>	100mA		120mA	
I <sub>CC1</sub>	30mA		35mA	

- Fully static operation
- High speed programming mode
- Single location programming
- Three state outputs
- Inputs and outputs TTL compatible
- Pin compatible with i2764A

## PIN CONNECTION (TOP VIEW)

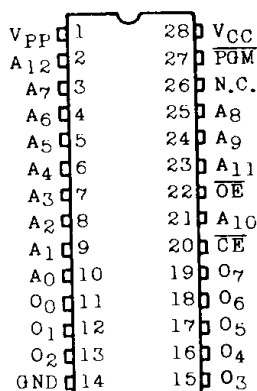

## PIN NAMES

A <sub>0</sub> ~A <sub>14</sub>	Address Inputs
O <sub>0</sub> ~O <sub>7</sub>	Outputs (Inputs)
$\overline{CE}$	Chip Enable Input
$\overline{OE}$	Output Enable Input
$\overline{PGM}$	Program Control Input
N. C.	No Connection
V <sub>PP</sub>	Program Supply Voltage
V <sub>CC</sub>	V <sub>CC</sub> Supply Voltage (+5V)
GND	Ground

## BLOCK DIAGRAM

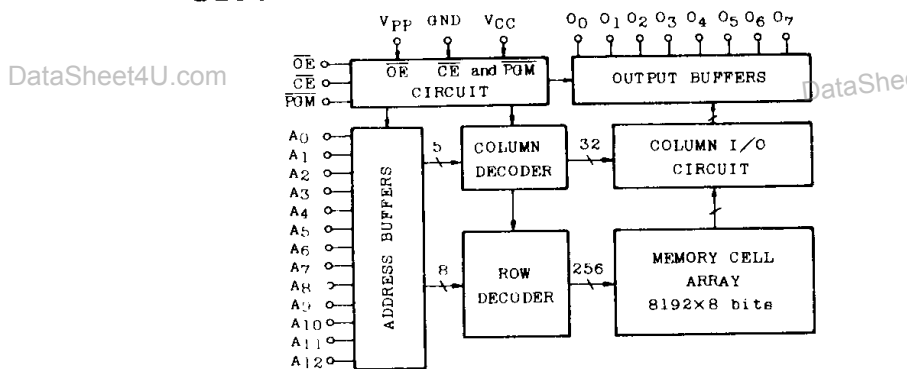

## MODE SELECTION

MODE	PIN PGM (27)	CE (20)	OE (22)	V <sub>PP</sub> (1)	V <sub>CC</sub> (28)	O <sub>0</sub> ~O <sub>7</sub> (11~13, 15~19)	POWER
Read	H	L	L	5V	5V	Data Out	Active
Output Deselect	*	*	H			High Impedance	
Standby	*	H	*	12.5V	6V	High Impedance	Standby
Program	L	L	*			Data In	Active
Program Inhibit	*	H	*			High Impedance	
Program Verify	H	L	H	High Impedance			
Program Verify	H	L	L			Data Out	

Note \* : H or L

# TMM2764AD-15, TMM2764AD-150 TMM2764AD-20, TMM2764AD-200

## MAXIMUM RATINGS

SYMBOL	ITEM	RATING	UNIT
V <sub>CC</sub>	V <sub>CC</sub> Power Supply Voltage	-0.6~7.0	V
V <sub>PP</sub>	Program Supply Voltage	-0.6~14.0	V
V <sub>IN</sub>	Input Voltage	-0.6~7.0	V
V <sub>OUT</sub>	Output Voltage	-0.6~7.0	V
P <sub>D</sub>	Power Dissipation	1.5	W
T <sub>SOLDER</sub>	Soldering Temperature · Time	260 · 10	°C·sec
T <sub>STRG</sub>	Storage Temperature	-65~125	°C
T <sub>OPR</sub>	Operating Temperature	0~70	°C

## READ OPERATION

### D. C. AND A. C. RECOMMENDED OPERATING CONDITIONS

SYMBOL	PARAMETER	TMM2764AD-15/20	TMM2764AD-150/200
T <sub>a</sub>	Operating Temperature	0~70°C	0~70°C
V <sub>CC</sub>	V <sub>CC</sub> Power Supply Voltage	5V±5%	5V±10%
V <sub>PP</sub>	V <sub>PP</sub> Power Supply Voltage	2.0~V <sub>CC</sub> ±0.6V	2.0~V <sub>CC</sub> ±0.6V

### D. C. AND OPERATING CHARACTERISTICS

SYMBOL	PARAMETER	CONDITION	MIN.	TYP.	MAX.	UNIT
I <sub>LI</sub>	Input Current	V <sub>IN</sub> =0~V <sub>CC</sub>	—	—	±10	μA
I <sub>LO</sub>	Output Leakage Current	V <sub>OUT</sub> =0.4~V <sub>CC</sub>	—	—	±10	μA
I <sub>CC1</sub>	Supply Current (Standby)	$\overline{CE}=V_{IH}$	-15/20	—	30	mA
			-150/200	—	35	
I <sub>CC2</sub>	Supply Current (Active)	$\overline{CE}=V_{IL}$	-15/20	—	100	mA
			-150/200	—	120	
V <sub>IH</sub>	Input High Voltage	—	2.0	—	V <sub>CC</sub> +1.0	V
V <sub>IL</sub>	Input Low Voltage	—	-0.3	—	0.8	V
V <sub>OH</sub>	Output High Voltage	I <sub>OH</sub> =-400μA	2.4	—	—	V
V <sub>OL</sub>	Output Low Voltage	I <sub>OL</sub> =2.1mA	—	—	0.4	V
I <sub>PP1</sub>	V <sub>PP</sub> Current	V <sub>PP</sub> =0~V <sub>CC</sub> +0.6	—	—	±10	μA

# TMM2764AD-15, TMM2764AD-150 TMM2764AD-20, TMM2764AD-200

## A. C. CHARACTERISTICS

SYMBOL	PARAMETER	TMM2764AD-15/150		TMM2764AD-20/200		UNIT
		MIN.	MAX.	MIN.	MAX.	
$t_{ACC}$	Address Access Time	—	150	—	200	ns
$t_{CE}$	CE to Output Valid	—	150	—	200	ns
$t_{OE}$	OE to Output Valid	—	70	—	70	ns
$t_{PGM}$	PGM to Output Valid	—	70	—	70	ns
$t_{DF1}$	CE to Output in High-Z	0	60	0	60	ns
$t_{DF2}$	OE to Output in High-Z	0	60	0	60	ns
$t_{DF3}$	PGM to Output in High-Z	0	60	0	60	ns
$t_{OH}$	Output Data Hold Time	0	—	0	—	ns

## A. C. TEST CONDITIONS

- Output Load : 1 TTL Gate and  $C_L = 100\text{pF}$
- Input Pulse Rise and Fall Times : 10ns Max.
- Input Pulse Levels : 0.45V to 2.4V
- Timing Measurement Reference Level : Inputs 0.8V and 2.0V, Outputs 0.8V and 2.0V

## CAPACITANCE \* ( $T_a = 25^\circ\text{C}$ , $f = 1\text{MHz}$ )

SYMBOL	PARAMETER	TEST CONDITION	MIN.	TYP.	MAX.	UNIT
$C_{IN}$	Input Capacitance	$V_{IN} = 0\text{V}$	—	4	6	pF
$C_{OUT}$	Output Capacitance	$V_{OUT} = 0\text{V}$	—	8	12	pF

\* This parameter is periodically sampled and is not 100% tested.

## TIMING WAVEFORMS (READ)

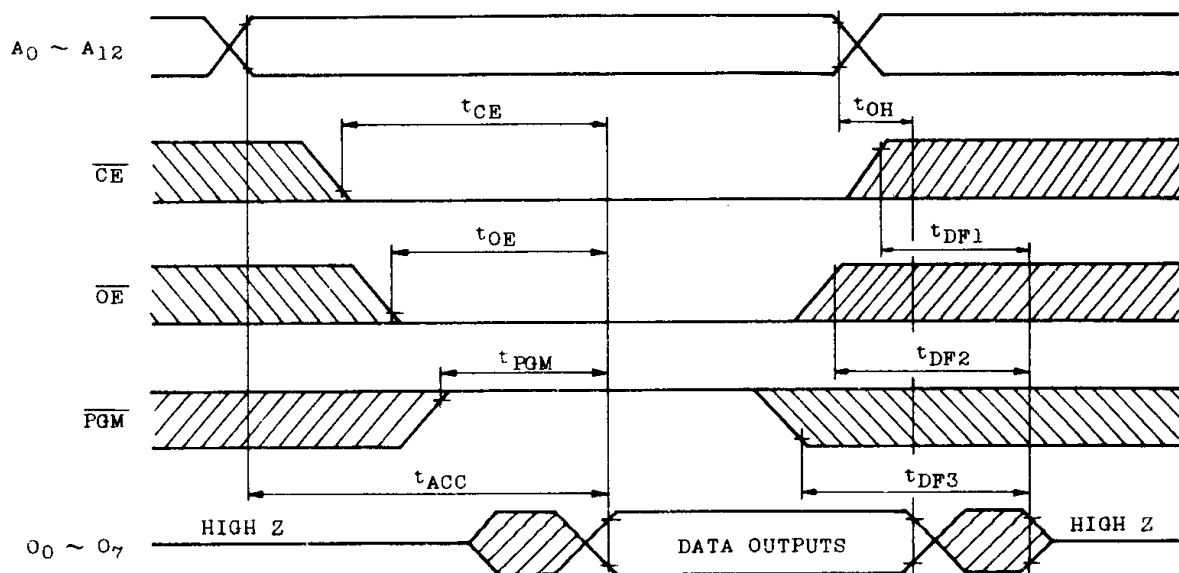

# TMM2764AD-15, TMM2764AD-150 TMM2764AD-20, TMM2764AD-200

## HIGH SPEED PROGRAM OPERATION

### D. C. RECOMMENDED OPERATING CONDITIONS

SYMBOL	PARAMETER	MIN.	TYP.	MAX.	UNIT
$V_{IH}$	Input High Voltage	2.0	—	$V_{CC} + 1.0$	V
$V_{IL}$	Input Low Voltage	-0.3	—	0.8	V
$V_{CC}$	$V_{CC}$ Power Supply Voltage	5.75	6.0	6.25	V
$V_{PP}$	$V_{PP}$ Power Supply Voltage	12.0	12.5	13.0	V

### D. C. and OPERATING CHARACTERISTICS ( $T_a = 25 \pm 5^\circ\text{C}$ , $V_{CC} = 6V \pm 0.25V$ , $V_{PP} = 12.5V \pm 0.5V$ )

SYMBOL	PARAMETER	TEST CONDITION	MIN.	TYP.	MAX.	UNIT
$I_{LI}$	Input Current	$V_{IN} = 0 \sim V_{CC}$	—	—	$\pm 10$	$\mu\text{A}$
$V_{OH}$	Output High Voltage	$I_{OH} = -400\mu\text{A}$	2.4	—	—	V
$V_{OL}$	Output Low Voltage	$I_{OL} = 2.1\text{mA}$	—	—	0.4	V
$I_{CC}$	$V_{CC}$ Supply Current	—	—	—	120	mA
$I_{PP2}$	$V_{PP}$ Supply Current	$V_{PP} = 13.0V$	—	—	50	mA
$V_{ID}$	A9 Auto Select Voltage	—	11.5	12.0	12.5	V

### A. C. PROGRAMMING CHARACTERISTICS ( $T_a = 25 \pm 5^\circ\text{C}$ , $V_{CC} = 6V \pm 0.25V$ , $V_{PP} = 12.5V \pm 0.5V$ )

SYMBOL	PARAMETER	TEST CONDITION	MIN.	TYP.	MAX.	UNIT
$t_{AS}$	Address Setup Time	—	2	—	—	$\mu\text{s}$
$t_{AH}$	Address Hold Time	—	2	—	—	$\mu\text{s}$
$t_{CES}$	$\overline{CE}$ Setup Time	—	2	—	—	$\mu\text{s}$
$t_{CEH}$	$\overline{CE}$ Hold Time	—	2	—	—	$\mu\text{s}$
$t_{DS}$	Data Setup Time	—	2	—	—	$\mu\text{s}$
$t_{DH}$	Data Hold Time	—	2	—	—	$\mu\text{s}$
$t_{VS}$	$V_{PP}$ Setup Time	—	2	—	—	$\mu\text{s}$
$t_{PW}$	Program Pulse Width	—	0.95	1.0	1.05	ms
$t_{OPW}$	Additional Program Pulse Width	Note 1	2.85	—	78.75	ms
$t_{PRT}$	Program Pulse Rise Time	—	5	—	—	ns
$t_{PFT}$	Program Pulse Fall Time	—	5	—	—	ns
$t_{OE}$	$\overline{OE}$ to Output Valid	—	—	—	100	ns
$t_{DF2}$	$\overline{OE}$ to Output in High Z	$\overline{CE} = V_{IL}$	—	—	90	ns

#### A. C. Test Conditions

- Output Load : 1 TTL Gate and  $C_L(100\text{pF})$
- Input Pulse Rise and Fall Time : 10ns Max.
- Input Pulse Levels : 0.45 to 2.4V
- Timing Measurement Reference Level : Input 1V and 2V ; Output 0.8V and 2.0V

Note : 1.  $t_{OPW}$  depends on the program pulse width which is required in the initial Program.

# TMM2764AD-15, TMM2764AD-150 TMM2764AD-20, TMM2764AD-200

## TIMING WAVEFORMS (PROGRAM)

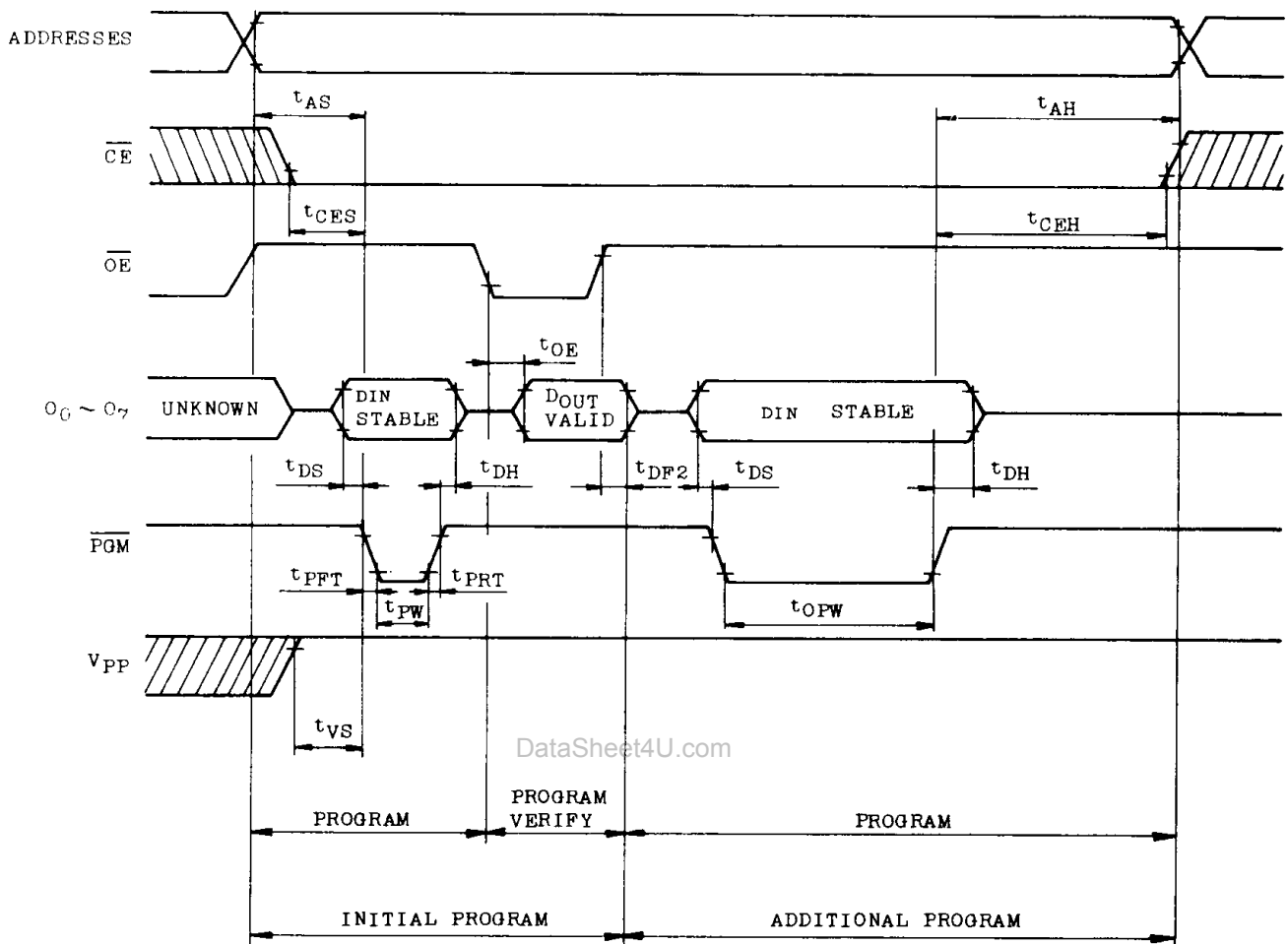

- Note :
1.  $V_{CC}$  must be applied simultaneously or before  $V_{PP}$  and cut off simultaneously or after  $V_{PP}$ .
  2. Removing the device from socket and setting the device in socket with  $V_{PP}=12.5V$  may cause permanent damage to the device.
  3. The  $V_{PP}$  supply voltage is permitted up to 14V for program operation, so the voltage over 14V should not be applied to the  $V_{PP}$  terminal.

When the switching pulse voltage is applied to the  $V_{PP}$  terminal, the overshoot voltage of its pulse should not be exceeded 14V.

# TMM2764AD-15, TMM2764AD-150 TMM2764AD-20, TMM2764AD-200

## ERASURE CHARACTERISTICS

The TMM2764AD's erasure is achieved by applying shortwave ultraviolet light which has a wave length of 2537Å (Angstroms) to the chip through the transparent window.

The integrated dose (Ultraviolet light intensity [ $\mu\text{w}/\text{cm}^2$ ]  $\times$  exposure time [sec.]) for erasure should be a minimum of 15 [ $\text{W sec}/\text{cm}^2$ ]

When the Toshiba sterilizing lamp GL-15 is used and the device is exposed at a distance of 1cm from the lamp surface, the erasure will be achieved within 60 minutes.

And using commercial lamps whose ultraviolet light intensity is 12000 [ $\mu\text{w}/\text{cm}^2$ ] will reduce the exposure time to about 20 minutes. (In this case, the integrated dose is 12000 [ $\mu\text{w}/\text{cm}^2$ ]  $\times$  (20 $\times$ 60) [sec]  $\cong$  15 [ $\text{W sec}/\text{cm}^2$ ].)

The TMM2764AD's erasure begins to occur when exposed to light with wavelength shorter than 4000Å. The sunlight and the fluorescent lamps will include 3000~4000Å wavelength components. Therefore when used under such lighting for extended periods of time, the opaque seals-Toshiba EPROM Protect Seal AC901-are available

## OPERATION INFORMATION

The TMM2764AD's six operation modes are listed in the following table.

Mode selection can be achieved by applying TTL level signal to all inputs.

In the read operation mode, a single 5V power supply is required and the levels required for all inputs are TTL

		PGM (27)	$\overline{\text{CE}}$ (20)	$\overline{\text{OE}}$ (22)	$V_{PP}$ (1)	$V_{CC}$ (28)	$O_0 \sim O_7$ (11~13, 15~19)	POWER
READ OPERATION ( $T_a = 0 \sim 70^\circ\text{C}$ )	Read	H	L	L	5V	5V	Data Out	Active
	Output Deselect	*	*	H			High Impedance	Active
	Standby	*	H	*			High Impedance	Standby
PROGRAM OPERATION ( $T_a = 25 \pm 5^\circ\text{C}$ )	Program	L	L	*	12.5V	6V	Data In	Active
	Program Inhibit	*	H	*			High Impedance	Active
	Program Verify	H	L	H			High Impedance	Active
		H	L	L			Data Out	Active

Note H :  $V_{IL}$ , L :  $V_{IL}$ , \* :  $V_{IH}$  or  $V_{IL}$

## READ MODE

The TMM2764AD has three control functions. The chip enable ( $\overline{\text{CE}}$ ) controls the operation power and should be used for device selection.

The output enable ( $\overline{\text{OE}}$ ) and the program control ( $\overline{\text{PGM}}$ ) control the output buffers, independent of device selection.

Assuming that  $\overline{\text{CE}} = \overline{\text{OE}} = V_{IL}$  and  $\overline{\text{PGM}} = V_{IH}$ , the output data is valid at the outputs after address access time from stabilizing of all addresses.

The  $\overline{\text{CE}}$  to output valid ( $t_{CE}$ ) is equal to the address access time ( $t_{ACC}$ ).

Assuming that  $\overline{\text{CE}} = V_{IL}$ ,  $\overline{\text{PGM}} = V_{IH}$  and all addresses are valid, the output data is valid at the outputs after  $t_{OE}$  from the falling edge of  $\overline{\text{OE}}$ .

And assuming that  $\overline{\text{CE}} = \overline{\text{OE}} = V_{IL}$  and all addresses are valid, the output data is valid at the outputs after  $t_{PGM}$  from the rising edge of  $\overline{\text{PGM}}$ .

## OUTPUT Deselect MODE

Assuming that  $\overline{\text{CE}} = V_{IH}$  or  $\overline{\text{OE}} = V_{IH}$ , the outputs will be in a high impedance state.

So two or more TMM2764AD can be connected

together on a common bus line.

When  $\overline{\text{CE}}$  is decoded for device selection, all deselected devices are in low power standby mode.

# TMM2764AD-15, TMM2764AD-150 TMM2764AD-20, TMM2764AD-200

## STANDBY MODE

The TMM2764AD has a low power standby mode controlled by the  $\overline{CE}$  signal.

By applying a TTL high level to the  $\overline{CE}$  input, the TMM2764AD is placed in the standby mode which

## PROGRAM MODE

Initially, when received by customers, all bits of the TMM2764AD are in the "1" state which is erased state.

Therefore the program operation is to introduce "0s" data into the desired bit locations by electrically

## PROGRAM VERIFY MODE

The verify mode is to check that the desired data is correctly programmed on the programmed bits.

## PROGRAM INHIBIT MODE

Under the condition that the program voltage (+12.5V) is applied to  $V_{PP}$  terminal, a high level  $\overline{CE}$  or  $\overline{PGM}$  input inhibits the TMM2764AD from being programmed.

Programming of two or more TMM2764AD's in parallel with different data is easily accomplished.

## HIGH SPEED PROGRAMMING MODE

The program time can be greatly decreased by using this high speed programming mode.

The device is set up in the high speed programming mode when the programming voltage (+12.5V) is applied to the  $V_{PP}$  terminal with  $V_{CC} = 6V$  and  $\overline{PGM} = V_{IH}$ .

The programming is achieved by applying a single TTL low level 1ms pulse the  $\overline{PGM}$  input after addresses and data are stable. Then the programmed data is verified by using Program Verify Mode.

If the programmed data is not correct, another

reduce 70% of the operating current and then the outputs are in a high impedance state, independent of the  $\overline{OE}$  and the  $\overline{PGM}$  inputs.

programming.

The levels required for all inputs are TTL.

The TMM2764AD can be programmed any location at anytime—either individually, sequentially, or at random.

The verify is accomplished with  $\overline{OE}$  and  $\overline{CE}$  at  $V_{IL}$  and  $\overline{PGM}$  at  $V_{IH}$ .

That is, all inputs except for  $\overline{CE}$  or  $\overline{PGM}$  may be commonly connected, and a TTL low level program pulse is applied to the  $\overline{CE}$  and  $\overline{PGM}$  of the desired device only and TTL high level signal is applied to the other devices.

program pulse of 1ms is applied and then programmed data is verified. This should be repeated until the program operates correctly (max. 25 times)

After correctly programming the selected address, one additional program pulse with pulse width 3 times that needed for programming is applied.

When programming has been completed, the data in all addresses should be verified with  $V_{CC} = V_{PP} = 5V$ .

**The High Speed Program II Algorithm (shown in figure 2, page G-5) may also be used to reduce the programming time further.**

# TMM2764AD-15, TMM2764AD-150 TMM2764AD-20, TMM2764AD-200

## HIGH SPEED PROGRAM MODE FLOW CHART

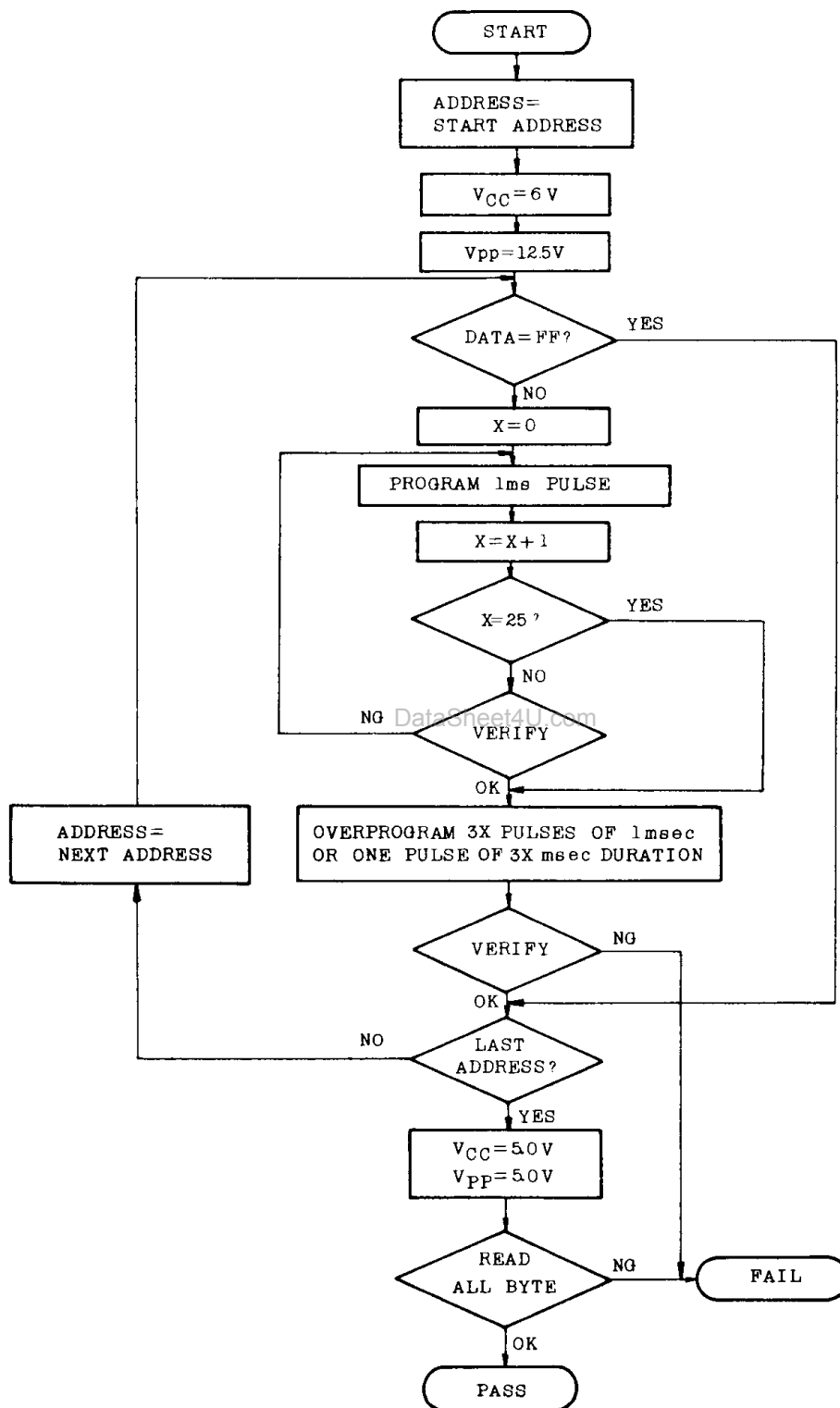



# TMM2764AD-15, TMM2764AD-150 TMM2764AD-20, TMM2764AD-200

## ELECTRIC SIGNATURE MODE

Electric signature mode allows to read out a code from TMM2764AD which identifies its manufacture and device type.

The programming equipment may read out manufacturer code and device code from TMM2764AD by using this mode before program operation and automatically set program voltage ( $V_{PP}$ ) and algorithm.

Electric signature mode is set up when 12V is

applied to address line A9 and the rest of address lines is set to  $V_{IL}$  in read operation. Data output in this conditions is manufacturer code. Device code is identified when address A0 is set to  $V_{IH}$ . These two codes possess an odd parity with the parity bit of MSB (O7).

The following table shows electric signature of TMM2764AD.

SIGNATURE \ PINS	A <sub>9</sub> (10)	O <sub>7</sub> (19)	O <sub>6</sub> (18)	O <sub>5</sub> (17)	O <sub>4</sub> (16)	O <sub>3</sub> (15)	O <sub>2</sub> (13)	O <sub>1</sub> (12)	O <sub>0</sub> (11)	HEX. DATA
Manufacture Code	$V_{IL}$	1	0	0	1	1	0	0	0	98
Device Code	$V_{IH}$	0	1	0	1	0	0	1	0	52

Notes : A9 = 12V ± 0.5V

A1 ~ A8, A10 ~ A12,  $\overline{CE}$ ,  $\overline{OE}$  =  $V_{IL}$

PGM =  $V_{IH}$

# TMM2764AD-15, TMM2764AD-150 TMM2764AD-20, TMM2764AD-200

## OUTLINE DRAWINGS

Unit in mm

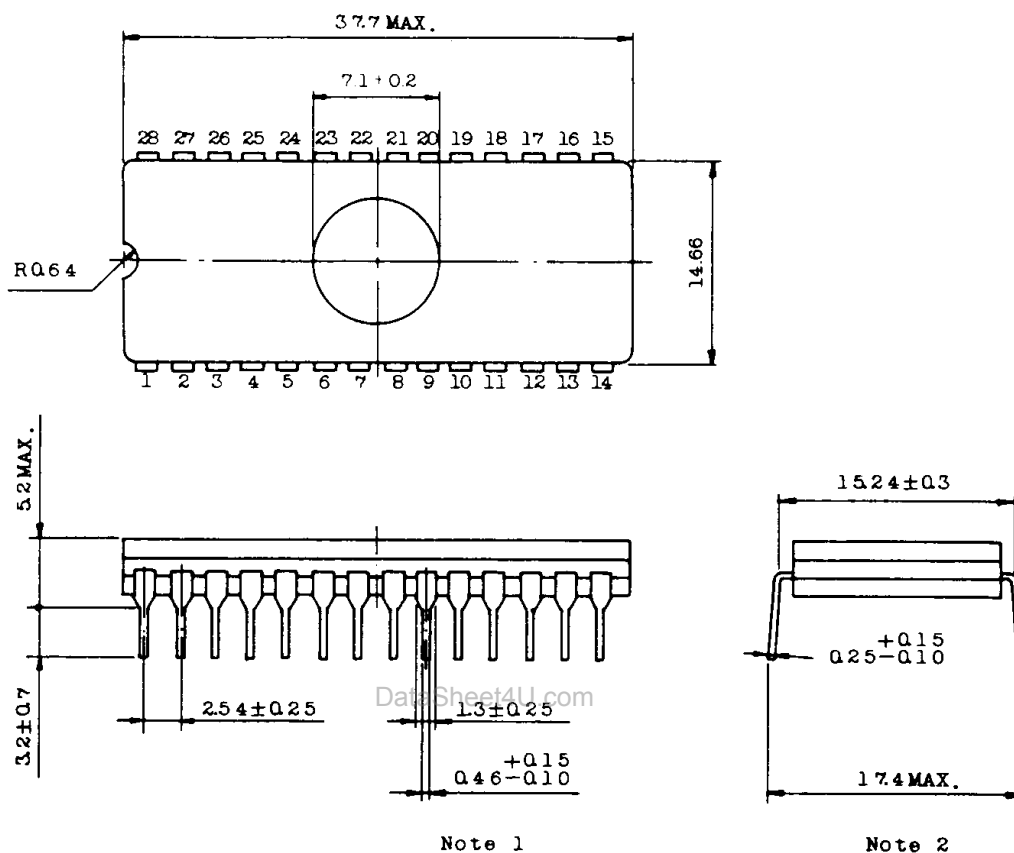

Note 1

Note 2

- Note: 1. Each lead pitch is 2.54mm. All leads are located within 0.25mm of their true longitudinal position with respect No.1 and No.28 leads.  
2. This value is measured at the end of leads.  
3. All dimensions are in millimeters.

Note: Toshiba does not assume any responsibility for use of any circuitry described; no circuit patent licenses are implied, and Toshiba reserves the right, at any time without notice, to change said circuitry.

©May., 1986 Toshiba Corporation