

MC33039, NCV33039

Closed Loop Brushless Motor Adapter

The MC33039 is a high performance closed-loop speed control adapter specifically designed for use in brushless DC motor control systems. Implementation will allow precise speed regulation without the need for a magnetic or optical tachometer. This device contains three input buffers each with hysteresis for noise immunity, three digital edge detectors, a programmable monostable, and an internal shunt regulator. Also included is an inverter output for use in systems that require conversion of sensor phasing. Although this device is primarily intended for use with the MC33035 brushless motor controller, it can be used cost effectively in many other closed-loop speed control applications.

- Digital Detection of Each Input Transition for Improved Low Speed Motor Operation
- TTL Compatible Inputs With Hysteresis
- Operation Down to 5.5 V for Direct Powering from MC33035 Reference
- Internal Shunt Regulator Allows Operation from a Non-Regulated Voltage Source
- Inverter Output for Easy Conversion between 60°/300° and 120°/240° Sensor Phasing Conventions



ON Semiconductor®

<http://onsemi.com>

MARKING DIAGRAMS

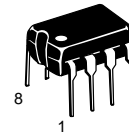

**DIP-8
N SUFFIX
CASE 626**

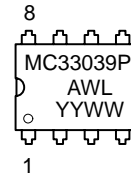

**SO-8
D SUFFIX
CASE 751**

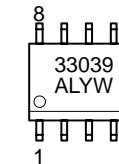

A = Assembly Location
WL, L = Wafer Lot
YY, Y = Year
WW, W = Work Week

PIN CONNECTIONS

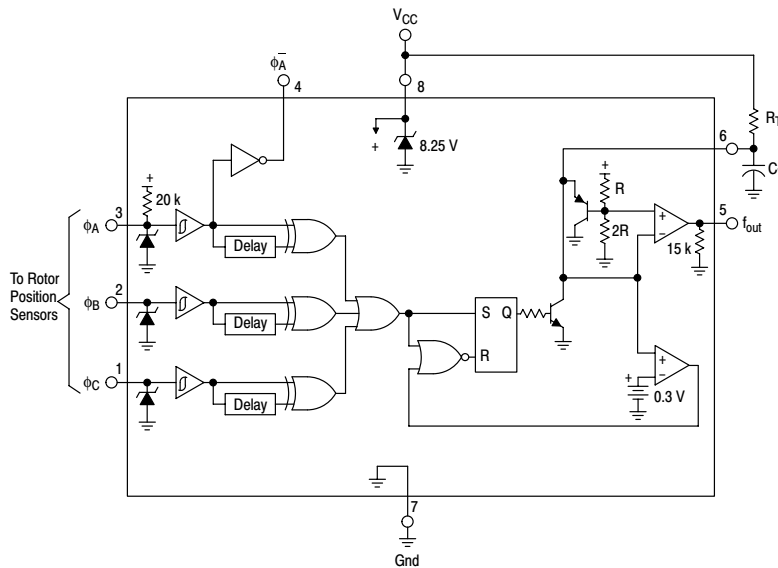
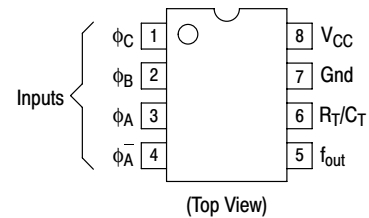

Representative Block Diagram

ORDERING INFORMATION

See detailed ordering and shipping information in the package dimensions section on page 6 of this data sheet.

MC33039, NCV33039

MAXIMUM RATINGS

Rating	Symbol	Value	Unit
V _{CC} Zener Current	I _{Z(V_{CC})}	30	mA
Logic Input Current (Pins 1, 2, 3)	I _{IH}	5.0	mA
Output Current (Pins 4, 5), Sink or Source	I _{DRV}	20	mA
Power Dissipation and Thermal Characteristics Maximum Power Dissipation @ T _A = +85°C Thermal Resistance, Junction-to-Air	P _D R _{θJA}	650 100	mW °C/W
Operating Junction Temperature	T _J	+150	°C
Operating Ambient Temperature Range MC33039 NCV33039	T _A	-40 to +85 -40 to +125	°C
Storage Temperature Range	T _{stg}	-65 to +150	°C

ELECTRICAL CHARACTERISTICS (V_{CC} = 6.25 V, R_T = 10 k, C_T = 22 nF, T_A = 25°C, unless otherwise noted)

Characteristic	Symbol	Min	Typ	Max	Unit
----------------	--------	-----	-----	-----	------

LOGIC INPUTS

Input Threshold Voltage					V
High State	V _{IH}	2.4	2.1	—	
Low State	V _{IL}	—	1.4	1.0	
Hysteresis	V _H	0.4	0.7	0.9	
Input Current					μA
High State (V _{IH} = 5.0 V)	I _{IH}	-40	-60	-80	
φ _A		—	-0.3	-5.0	
φ _B , φ _C					
Low State (V _{IL} = 0 V)	I _{IL}	-190	-300	-380	
φ _A		—	-0.3	-5.0	
φ _B , φ _C					

MONOSTABLE AND OUTPUT SECTIONS

Output Voltage					V
High State	V _{OH}	3.60	3.95	4.20	
f _{out} (I _{source} = 5.0 mA)		4.20	4.75	—	
φ _A (I _{source} = 2.0 mA)					
Low State	V _{OL}	—	0.25	0.50	
f _{out} (I _{sink} = 10 mA)		—	0.25	0.50	
φ _A (I _{sink} = 10 mA)					
Capacitor C _T Discharge Current	I _{dischg}	20	35	60	mA
Output Pulse Width (Pin 5)	t _{PW}	205	225	245	μs

POWER SUPPLY SECTION

Power Supply Operating Voltage Range MC33039 (T _A = -40° to +85°C) NCV33039 (T _A = -40° to +125°C)	V _{CC}	5.5	—	V _Z	V
Power Supply Current	I _{CC}	1.8	3.9	5.0	mA
Zener Voltage (I _Z = 10 mA)	V _Z	7.5	8.25	9.0	V
Zener Dynamic Impedance (ΔI _Z = 10 mA to 20 mA, f ≤ 1.0 kHz)	Z _{ka}	—	2.0	5.0	Ω

MC33039, NCV33039

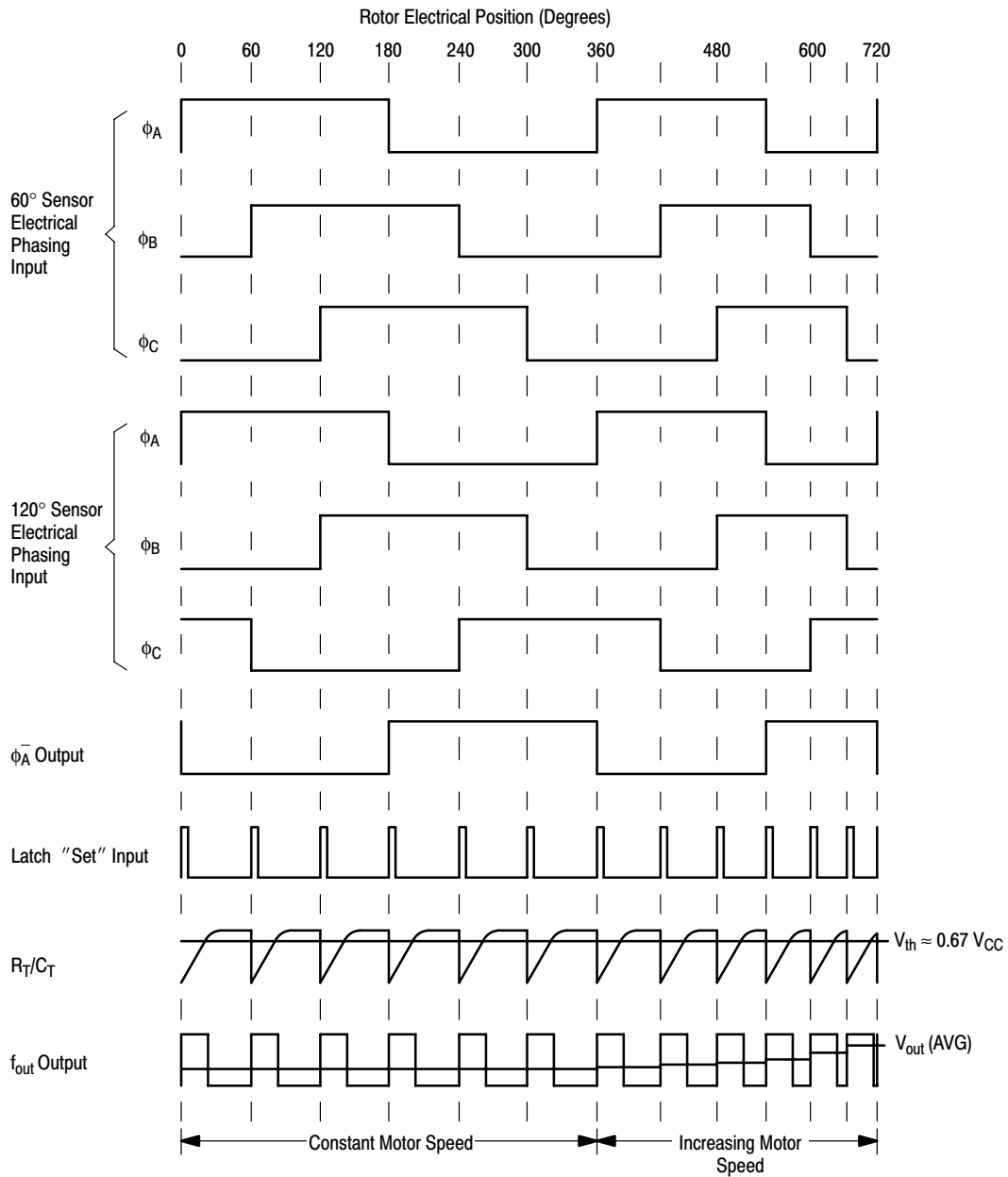

Figure 1. Typical Three Phase, Six Step Motor Application

OPERATING DESCRIPTION

The MC33039 provides an economical method of implementing closed-loop speed control of brushless DC motors by eliminating the need for a magnetic or optical tachometer. Shown in the timing diagram of Figure 1, the three inputs (Pins 1, 2, 3) monitor the brushless motor rotor position sensors. Each sensor signal transition is digitally detected, OR'ed at the Latch 'Set' Input, and causes C_T to discharge. A corresponding output pulse is generated at f_{out} (Pin 5) of a defined amplitude, and programmable width determined by the values selected for R_T and C_T (Pin 6). The average voltage of the output pulse train increases with motor speed. When fed through a low pass filter or integrator, a DC voltage proportional to speed is generated. Figure 2 shows the proper connections for a typical closed

loop application using the MC33035 brushless motor controller. Constant speed operation down to 100 RPM is possible with economical three phase four pole motors.

The ϕ_A inverter output (Pin 4) is used in systems where the controller and motor sensor phasing conventions are not compatible. A method of converting from either convention to the other is shown in Figure 3. For a more detailed explanation of this subject, refer to the text above Figure 39 on the MC33035 data sheet.

The output pulse amplitude V_{OH} is constant with temperature and controlled by the supply voltage on V_{CC} (Pin 8). Operation down to 5.5 V is guaranteed over temperature. For systems without a regulated power supply, an internal 8.25 V shunt regulator is provided.

MC33039, NCV33039

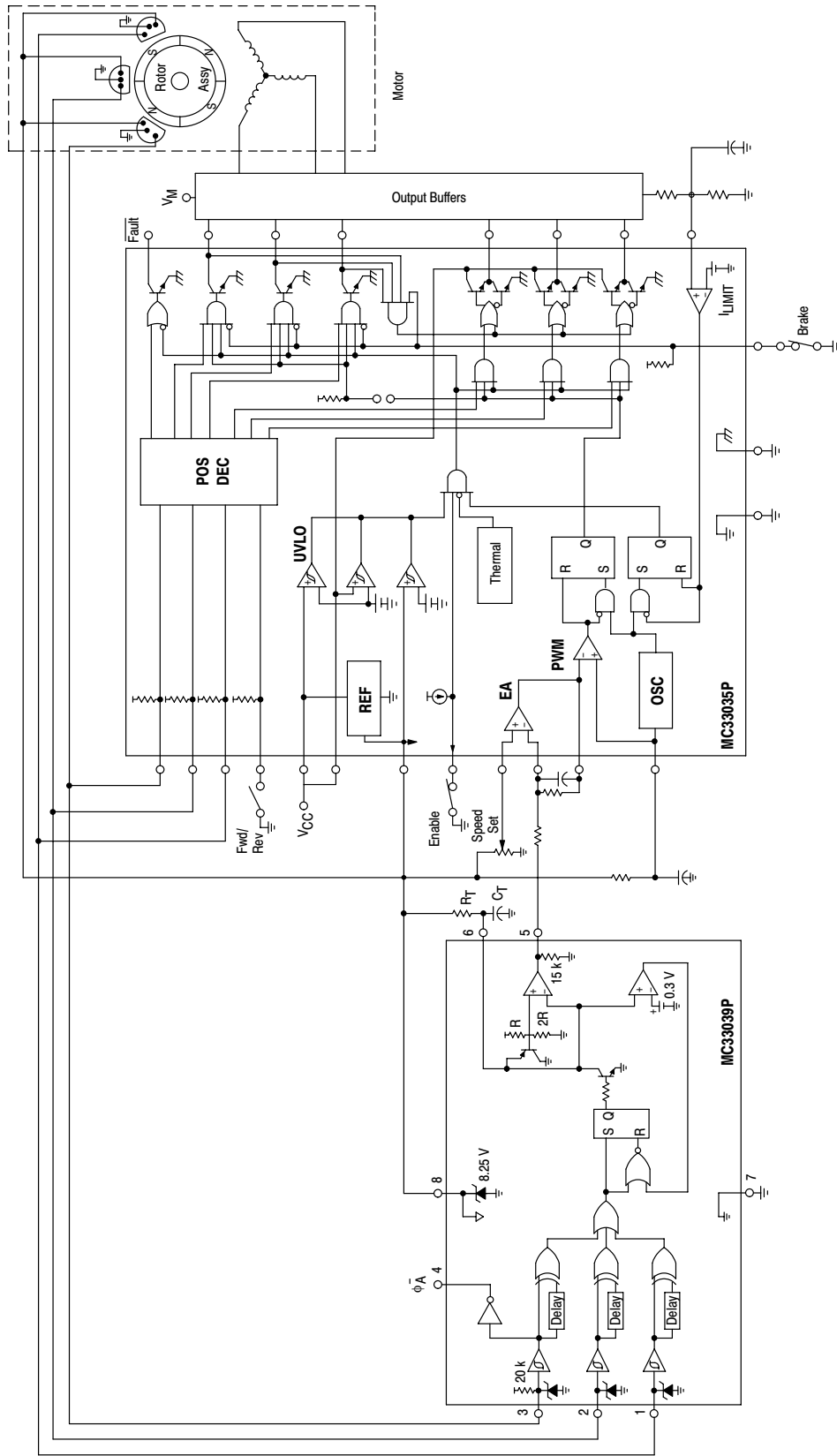

Figure 2. Typical Closed Loop Speed Control Application

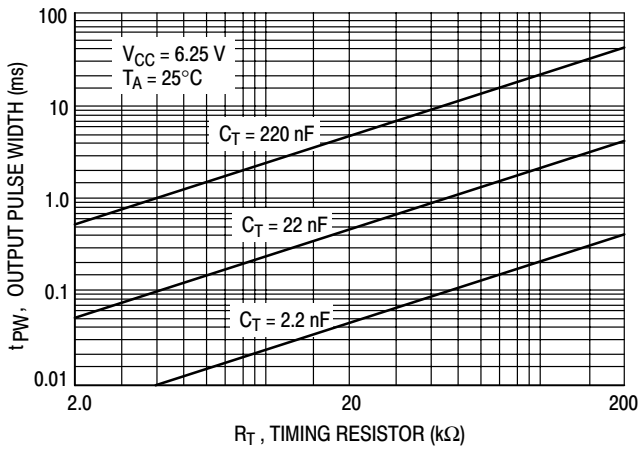

Figure 3. f_{out} , Pulse Width versus Timing Resistor

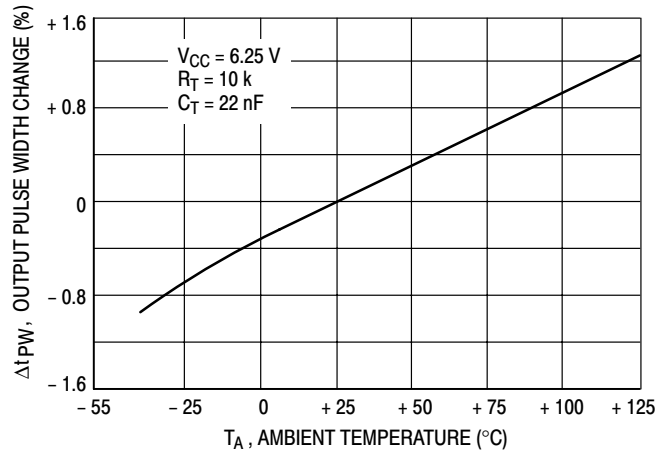

Figure 4. f_{out} , Pulse Width Change versus Temperature

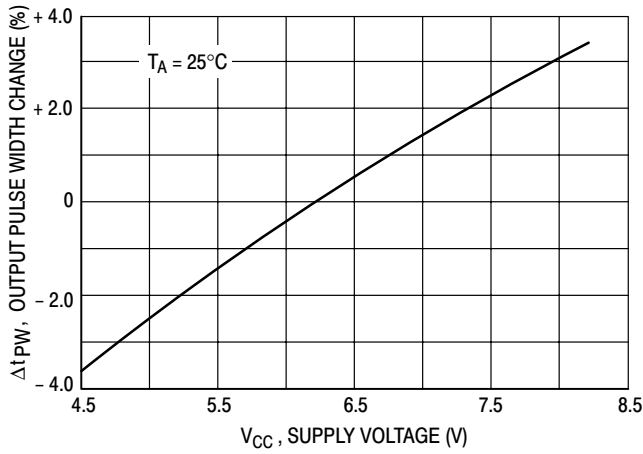

Figure 5. f_{out} , Pulse Width Change versus Supply Voltage

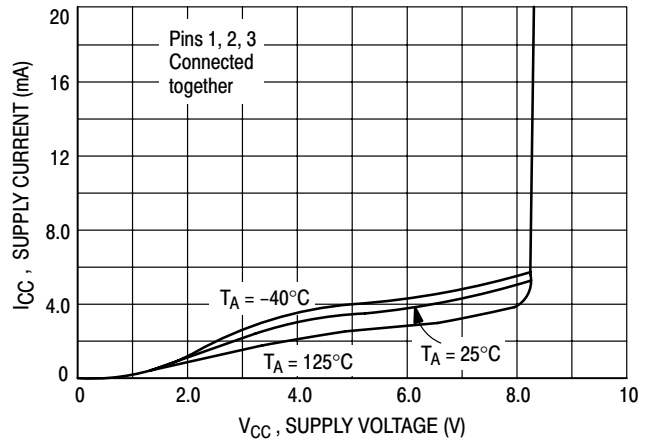

Figure 6. Supply Current versus Supply Voltage

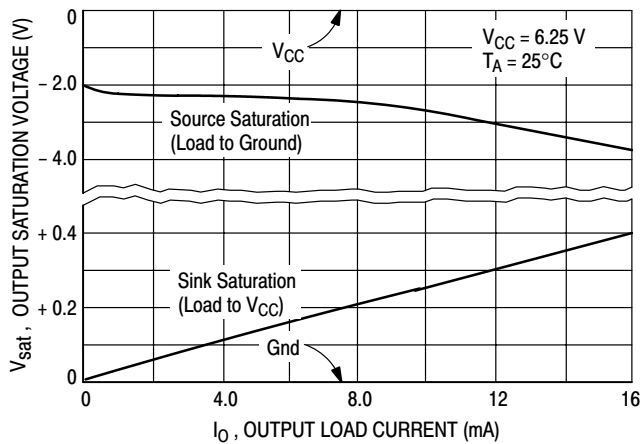

Figure 7. f_{out} , Saturation versus Load Current

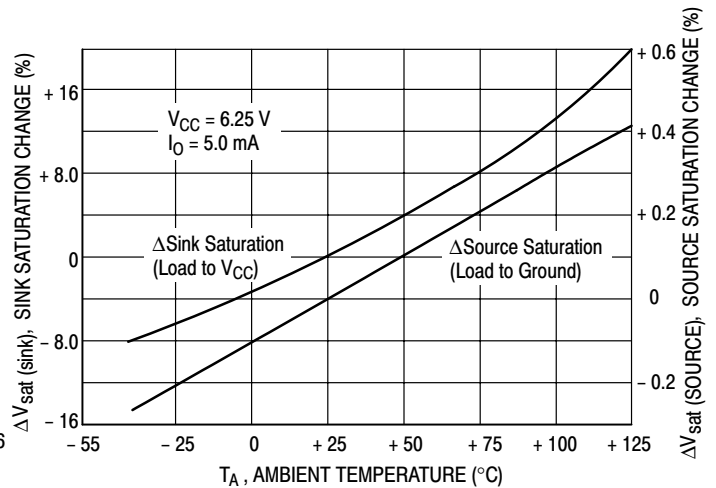
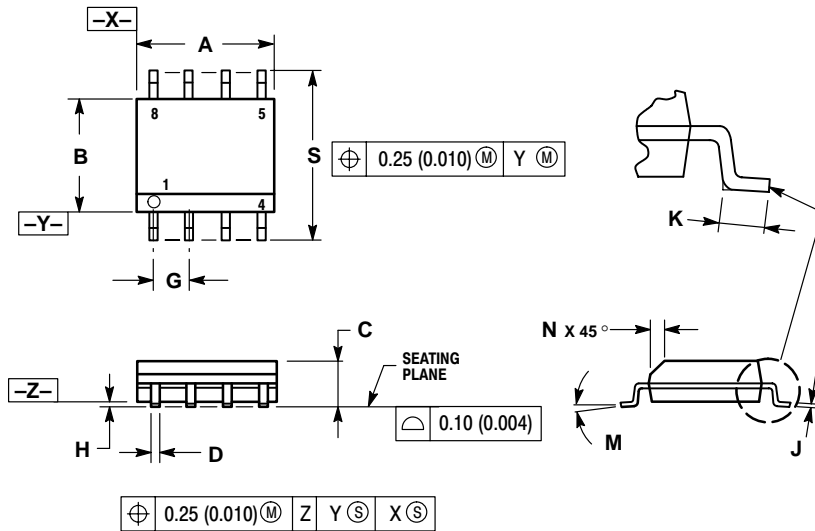

Figure 8. f_{out} , Saturation Change versus Temperature

MC33039, NCV33039

PACKAGE DIMENSIONS

D SUFFIX
PLASTIC PACKAGE
CASE 751-07
ISSUE W



- NOTES:
1. DIMENSIONING AND TOLERANCING PER ANSI Y14.5M, 1982.
 2. CONTROLLING DIMENSION: MILLIMETER.
 3. DIMENSION A AND B DO NOT INCLUDE MOLD PROTRUSION.
 4. MAXIMUM MOLD PROTRUSION 0.15 (0.006) PER SIDE.
 5. DIMENSION D DOES NOT INCLUDE DAMBAR PROTRUSION. ALLOWABLE DAMBAR PROTRUSION SHALL BE 0.127 (0.005) TOTAL IN EXCESS OF THE D DIMENSION AT MAXIMUM MATERIAL CONDITION.

DIM	MILLIMETERS		INCHES	
	MIN	MAX	MIN	MAX
A	4.80	5.00	0.189	0.197
B	3.80	4.00	0.150	0.157
C	1.35	1.75	0.053	0.069
D	0.33	0.51	0.013	0.020
G	1.27 BSC		0.050 BSC	
H	0.10	0.25	0.004	0.010
J	0.19	0.25	0.007	0.010
K	0.40	1.27	0.016	0.050
M	0°	8°	0°	8°
N	0.25	0.50	0.010	0.020
S	5.80	6.20	0.228	0.244

ON Semiconductor and  are registered trademarks of Semiconductor Components Industries, LLC (SCILLC). SCILLC reserves the right to make changes without further notice to any products herein. SCILLC makes no warranty, representation or guarantee regarding the suitability of its products for any particular purpose, nor does SCILLC assume any liability arising out of the application or use of any product or circuit, and specifically disclaims any and all liability, including without limitation special, consequential or incidental damages. "Typical" parameters which may be provided in SCILLC data sheets and/or specifications can and do vary in different applications and actual performance may vary over time. All operating parameters, including "Typicals" must be validated for each customer application by customer's technical experts. SCILLC does not convey any license under its patent rights nor the rights of others. SCILLC products are not designed, intended, or authorized for use as components in systems intended for surgical implant into the body, or other applications intended to support or sustain life, or for any other application in which the failure of the SCILLC product could create a situation where personal injury or death may occur. Should Buyer purchase or use SCILLC products for any such unintended or unauthorized application, Buyer shall indemnify and hold SCILLC and its officers, employees, subsidiaries, affiliates, and distributors harmless against all claims, costs, damages, and expenses, and reasonable attorney fees arising out of, directly or indirectly, any claim of personal injury or death associated with such unintended or unauthorized use, even if such claim alleges that SCILLC was negligent regarding the design or manufacture of the part. SCILLC is an Equal Opportunity/Affirmative Action Employer.

PUBLICATION ORDERING INFORMATION

Literature Fulfillment:

Literature Distribution Center for ON Semiconductor
P.O. Box 5163, Denver, Colorado 80217 USA
Phone: 303-675-2175 or 800-344-3860 Toll Free USA/Canada
Fax: 303-675-2176 or 800-344-3867 Toll Free USA/Canada
Email: ONlit@hibbertco.com

N. American Technical Support: 800-282-9855 Toll Free USA/Canada

JAPAN: ON Semiconductor, Japan Customer Focus Center
4-32-1 Nishi-Gotanda, Shinagawa-ku, Tokyo, Japan 141-0031
Phone: 81-3-5740-2700
Email: r14525@onsemi.com

ON Semiconductor Website: <http://onsemi.com>

For additional information, please contact your local Sales Representative.