

# NEW

# MCP ASSEMBLY

## F9890-11/-12, F9892-11/-12

### HIGH TIME RESOLUTION TOF-MS DETECTOR HIGH VOLTAGE FLOATING OPERATION

#### FEATURES

- High voltage floating operation  
MCP-IN  $\pm 10$  kV
- Fast time response
- Large effective area  
F9890-11/-12  $\phi 27$  mm  
F9892-11/-12  $\phi 42$  mm
- Excellent MCP flatness
- Robust MCP
- Less ringing
- Small time jitter

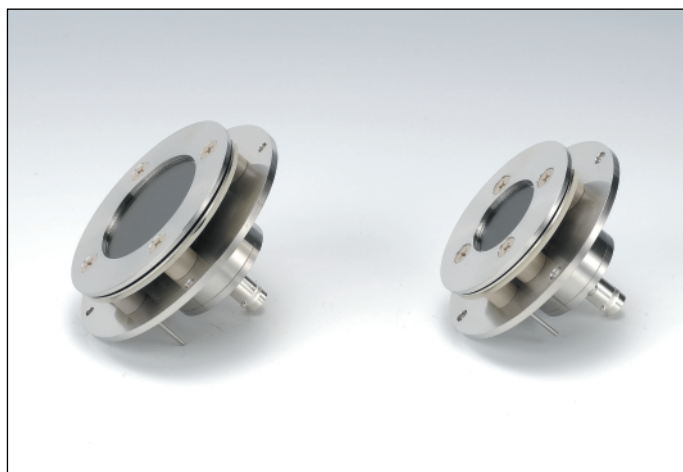

#### OVERVIEW

The F9890-11/-12 and F9892-11/-12 are ideal detectors with large effective area for TOF-MS (Time of Flight Mass Spectrometry).

Our own advanced technology in optimizing the assembly design with flat MCP allows excellent time resolution of 1.2 ns (FWHM: F9892-11/-12) with negligible ringing at both  $\pm 10$  kV high voltage floating operation.

Figure 1: Typical Output Waveform (F9892-12)

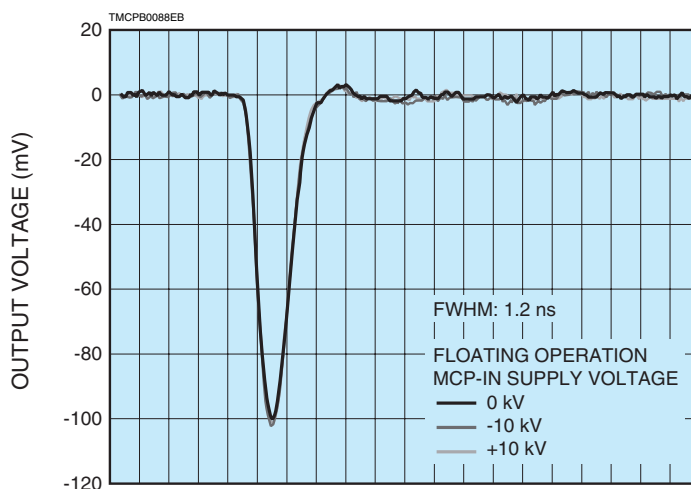

RESPONSE TIME (1 ns/div.)

# SPECIFICATIONS

## GENERAL

Parameter	F9890-11	F9890-12	F9892-11	F9892-12	Unit
MCP Channel Diameter	12	6	12	6	μm
Bias Angle	12				degree
Effective Area	φ27		φ42		mm
Assembly Outer Size	φ81		φ92		mm
Assembly Height Size	54.1	53.7	54.1	53.7	mm
Number of MCPs	2				—

## TYPICAL ELECTRICAL CHARACTERISTICS (Supply Voltage: 2 kV, Vacuum: $1.3 \times 10^{-4}$ Pa, Operating Ambient Temperature: +25 °C)

Parameter	F9890-11	F9890-12	F9892-11	F9892-12	Unit
Gain (Min.)	$1 \times 10^6$				—
Plate Resistance per MCP	10 to 40		8 to 32		MΩ
Dark Count (Max.)	3				$s^{-1} \cdot cm^{-2}$
Pulse Width (FWHM) (TYP.)	0.9		1.2		ns

## RATINGS

Parameter	F9890-11	F9890-12	F9892-11	F9892-12	Unit
MCP Supply Voltage (Max.)	2.0				kV
MCP-OUT to Anode Supply Voltage (Max.)	0.5				kV
MCP-IN Supply Voltage (Max.)	±10				kV
Operating Vacuum Condition (Max.)	$1.3 \times 10^{-4}$ <sup>(A)</sup>				Pa

NOTE: (A) Better vacuum than  $1.3 \times 10^{-4}$  Pa.

## DIMENSIONAL OUTLINES (Unit: mm)

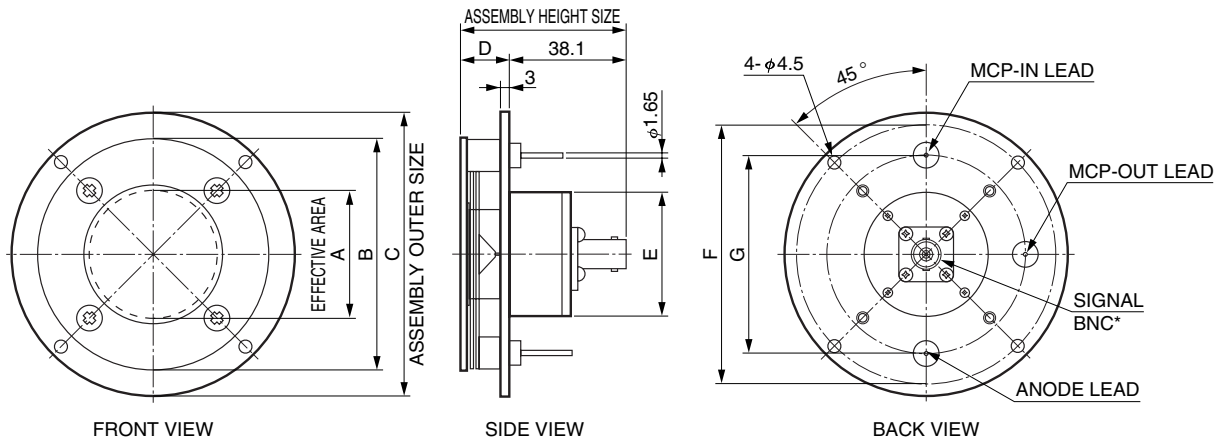

\* SMA connector type also available.

Type No.	A	B	C	D	E	F	G
F9890-11	φ27	φ63	φ81	16	φ35	φ72	φ52
F9890-12				15.6			
F9892-11	φ42	φ75	φ92	16	φ40	φ84	φ64
F9892-12				15.6			

### CIRCUIT DIAGRAM

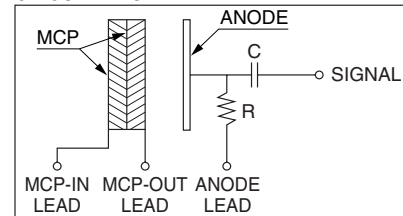

TMCPA0072EA

Subject to local technical requirements and regulations, availability of products included in this promotional material may vary. Please consult with our sales office. Information furnished by HAMAMATSU is believed to be reliable. However, no responsibility is assumed for possible inaccuracies or omissions. Specifications are subject to change without notice. No patent rights are granted to any of the circuits described herein. ©2007 Hamamatsu Photonics K.K.

# HAMAMATSU

WEB SITE [www.hamamatsu.com](http://www.hamamatsu.com)

HAMAMATSU PHOTONICS K.K., Electron Tube Division

314-5, Shimokanzo, Iwata City, Shizuoka Pref., 438-0193, Japan, Telephone: (81)539/62-5248, Fax: (81)539/62-2205

U.S.A.: Hamamatsu Corporation, 360 Foothill Road, P. O. Box 6910, Bridgewater, N.J. 08807-0910, U.S.A., Telephone: (1)908-231-0960, Fax: (1)908-231-1218 E-mail: [usa@hamamatsu.com](mailto:usa@hamamatsu.com)

Germany: Hamamatsu Photonics Deutschland GmbH: Arzbergerstr. 10, D-82211 Herrsching am Ammersee, Germany, Telephone: (49)8152-375-0, Fax: (49)8152-2658 E-mail: [info@hamamatsu.de](mailto:info@hamamatsu.de)

France: Hamamatsu Photonics France S.A.R.L.: 19, Rue du Saule Trapu, Parc du Moulin de Massy, 91882 Massy Cedex, France, Telephone: (33)1 69 53 71 00, Fax: (33)1 69 53 71 10 E-mail: [infos@hamamatsu.fr](mailto:infos@hamamatsu.fr)

United Kingdom: Hamamatsu Photonics UK Limited: 2 Howard Court, 10 Tewin Road Welwyn Garden City Hertfordshire AL7 1BW, United Kingdom, Telephone: 44-(0)1707-294888, Fax: 44(0)1707-325777 E-mail: [info@hamamatsu.co.uk](mailto:info@hamamatsu.co.uk)

North Europe: Hamamatsu Photonics Norden AB: Smidsvägen 12, SE-171-41 SOLNA, Sweden, Telephone: (46)8-509-031-00, Fax: (46)8-509-031-01 E-mail: [info@hamamatsu.se](mailto:info@hamamatsu.se)

Italy: Hamamatsu Photonics Italia: S.R.L.: Strada della Moia, 1/E, 20020 Arese, (Milano), Italy, Telephone: (39)02-935 81 733, Fax: (39)02-935 81 741 E-mail: [info@hamamatsu.it](mailto:info@hamamatsu.it)

TMCP1033E01  
MAY 2007 IP