

# MAGNUM

## Terminal Blocks Catalog



## Contents

	PAGES
<b>BARRIER STYLE TERMINAL BLOCKS</b>	
Magnum® 5000 Series .250" Centers; 10A, 300V	2-3
Magnum® 1000 Series .325" Centers; 15A, 250V	4-6
Magnum® 2000 Series .375" Centers; 30A, 150-300V	7-12
Magnum® 3000 Series .437" Centers; 30A, 150-600V	13-18
Magnum® A38/B38 Series .437" Centers; 30-50A, 300-600V	19-20
Magnum® 4000 Series .562" Centers; 35-50A, 150-600V	21-22
Magnum® Accessories Marking, Marker Strips, Covers	23-24
<b>DOUBLE ROW TERMINAL BLOCKS</b>	
Magnum® TB Series 100 .375" Centers; 20A, 150-250V	25-26
Magnum® TB Series 200 .437" Centers; 20A, 300-600V	27-28
Magnum® TB Series 300 .562" Centers; 30-45A, 600V	29-30
Magnum® TB Series 400 .687" Centers; 75A, 600V	31
Magnum® TB Series Accessories Marking, Marker Strips, Covers	32-33
<b>EUROPEAN STYLE TERMINAL BLOCKS</b>	
Euro-Mag® .150" Centers; 10A, 125V	
EM3503 Series – Single Piece	36
EM3563 Series – Depluggable	48
EM3573 Series – Header	54
Euro-Mag® .197" Centers; 10-15A, 300V	
EM2585 Series – Single Piece, Stackable	35
EM2665 Series – Single Piece	37
EM3665 Series – Single Piece, Low Profile	38
EM3675 Series – Single Piece, Stackable	39
EM2555 Series – 45° Angle, Stackable	42
EM2445 Series – Two-Tier, Stackable	44
EM2525 Series – Depluggable, Horizontal	46
EM2465 Series – Depluggable, Vertical	47
EM5015 Series – Depluggable	49
EM2535 Series – Header (Mates with EM2525)	52
EM2475 Series – Header (Mates with EM2465)	53
EM5025 Series – Header (Mates with EM5015)	50
Euro-Mag® .200" Centers; 10-15A, 300V	
EM2505 Series – Single Piece, Stackable	34
EM2515 Series – 45° Angle, Stackable	40
EM2545 Series – Two-Tier, Stackable	43
EM2565 Series – Depluggable	45
EM2575 Series – Header (Mates with EM2565)	51
EM2795 Series – Screwless, Stackable	41
Euro-Mag® .300" Centers; 15A, 300V	
EM7000 Series – Two-Tier	55
<b>I/O CONNECTORS</b>	
Magnum® 15133 Series .375" Centers; 20A, 300V	56
Magnum® 13926 Series .200" Centers; 8A, 250V	57
Magnum® 1384X Series .375" Centers; 5A, 250V	58
Magnum® 15104 Series .375" Centers; 10A, 300V	59
<b>INTERFACE SYSTEMS</b>	
Mag-Master® 7000 Series	60-63
<b>CUSTOM PRODUCTS</b>	
	64-65
<b>COMPLIANCE REFERENCES</b>	
UL, CSA, IEC, CE	66

This catalog is intended to present product data and provide technical information that will help you, the end user, with design application. Bussmann reserves the right, without notice, to change design or construction of any products and to discontinue or limit distribution of any products. Bussmann also reserves the right to change or update, without notice, any technical information contained in this catalog. Once a product has been selected, it should be tested by the user in all possible applications.

# MAGNUM®

## Series A5000 & Series CB5000

### Single Row Terminal Blocks

#### SPECIFICATIONS

**Rating:** 10A, 300V\*

**Center Spacing:** .250" (6.35 mm)

**Wire Size:** #16-30 AWG CU

**Screw Size:** #3-48 zinc plated phillslot SEMS screws, wire-ready standard

**Torque Rating:** 4 in.-lbs. max.

**Distance Between Barriers:** .20" (5.08 mm)

**Recommended PCB Hole Diameter:** .062" (1.57 mm)

**Operating Temperature:** 105°C (221°F) max., -40°C (-40°F) min.

**Molded Material:** Black, UL Rated 94VO Thermoplastic

**Breakdown Voltage:** 1600V rms

**Approvals:** UL E62622; CSA LR15364; CE Certified

\* Max. rating shown; some options may be rated lower – consult factory.

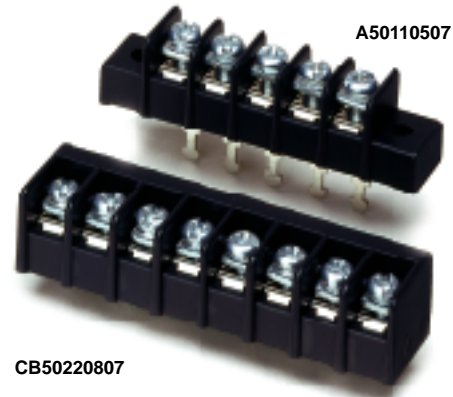

Poles	MOUNTING ENDS		BARRIER ENDS	
	A Mount Centers	B Overall Length	A Pole Centers	B Overall Length
02	.75	1.06	.25	.56
03	1.00	1.31	.50	.81
04	1.25	1.56	.75	1.06
05	1.50	1.81	1.00	1.31
06	1.75	2.06	1.25	1.56
07	2.00	2.31	1.50	1.81
08	2.25	2.56	1.75	2.06
09	2.50	2.81	2.00	2.31
10	2.75	3.06	2.25	2.56
11	3.00	3.31	2.50	2.81
12	3.25	3.56	2.75	3.06
13	3.50	3.81	3.00	3.31
14	3.75	4.06	3.25	3.56
15	4.00	4.31	3.50	3.81
16	4.25	4.56	3.75	4.06
17	4.50	4.81	4.00	4.31
18	4.75	5.06	4.25	4.56
19	5.00	5.31	4.50	4.81
20	5.25	5.56	4.75	5.06
21	5.50	5.81	5.00	5.31
22	5.75	6.06	5.25	5.56
23	6.00	6.31	5.50	5.81
24	6.25	6.56	5.75	6.06
25	6.50	6.81	6.00	6.31
26	6.75	7.06	6.25	6.56
27	7.00	7.31	6.50	6.81
28	7.25	7.56	6.75	7.06
29			7.00	7.31
30			7.25	7.56

\* Dimensions in inches. To convert to millimeters, multiply by 25.4.

#### A5000 Series

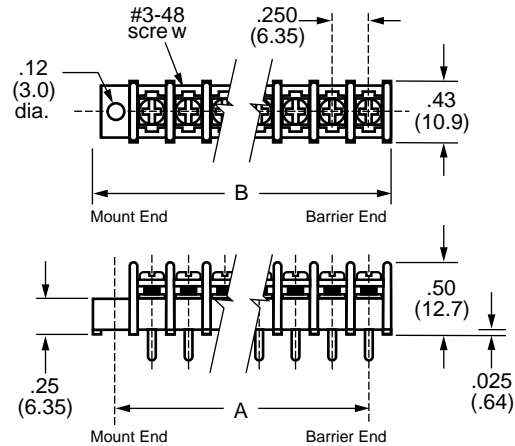

#### CB5000 Series

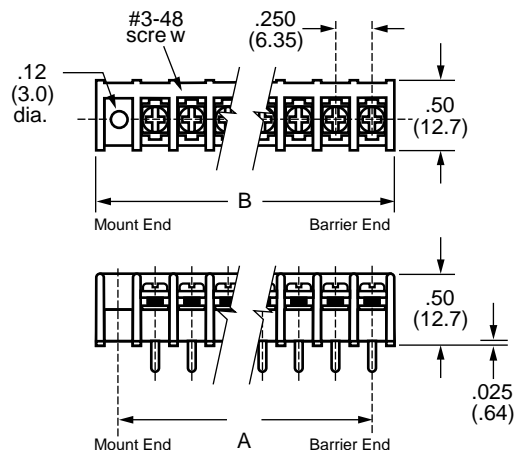

## Part Numbering System

Series	Terminal Style	Base/End	Poles	Screw Options	Options
A5 CB5	nn	n	nn nn	nn	nnn
A5 - standard barrier CB5 - closed barrier	01 - handwired 02 - printed circuit 03 - non feed-thru 04 - wire wrap tail	1 - mount end 2 - barrier end	02 to 30 02 to 28 on mount end base	07 - steel SEMS std. wire ready	C1 to C8 - .110" QC L1 to L6 marking options (pg 23) LT1 to LT6 marking options (CB5 only-pg 23) OJ - over barrier jumper S1 - single solder lug/flat S2 - double solder lug/flat (A5 only)

## Terminal Styles

Inches (Millimeters)

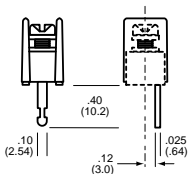

01  
Handwired

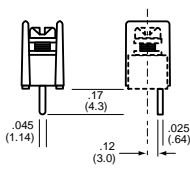

02  
Circuit Board



03  
Non Feed-Thru

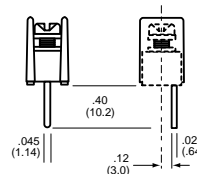

04  
Wire Wrap Tail

## CB5 Terminal Exit Options

Inches (Millimeters)

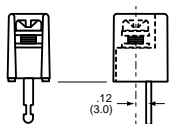

Exit Rear (std.)

## Screw Options Wire ready screws standard on all terminal styles



07  
Steel SEMS  
Zinc Plated



07  
Standard  
Wire Ready

## Hardware Options (Bulk ordering part numbers are in parentheses.)

### Jumpers



OJ12

### Quick Connects Blade Width .110" (For other orientations, contact factory.)

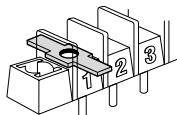

C1 (5C1) \*

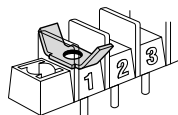

C2 (5C2) \*

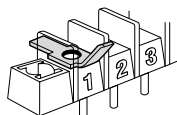

C4 (5C4) \*

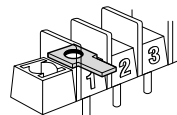

C7 (5C7)

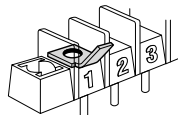

C8 (5C8)

### Solder Lugs

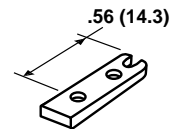

S1 (5S1)

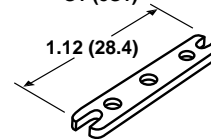

S2 (5S2)

\* N/A on CB5 Series.



# MAGNUM<sup>®</sup>

## Series A1000 & Series CB1000

### Single Row Terminal Blocks

#### SPECIFICATIONS

**Rating:** 15A, 250V

**Center Spacing:** .325" (8.26 mm)

**Wire Size:** #14-22 AWG CU

**Screw Size:** #6-32 zinc plated phillot wire-ready screws with a #2 driving recess.

**Torque Rating:** 9 in-lb. max.

**Base:** Standoffs are standard on CB1000 Series for easy flux washing.

**Distance Between Barriers:** .26" (6.6 mm)

**Recommended PCB Hole Diameter:** .070" (1.78 mm)

**Operating Temperature:** 105°F (221°F) max., -40°C

(-40°F) min.

**Molded Material:** Black, UL Rated 94VO Thermoplastic

**Breakdown Voltage:** 1600V rms

**Approvals:** UL E62622; CSA LR15364; IEC Compliance; CE Certified



A102206



CB10210707

#### A1000 Series

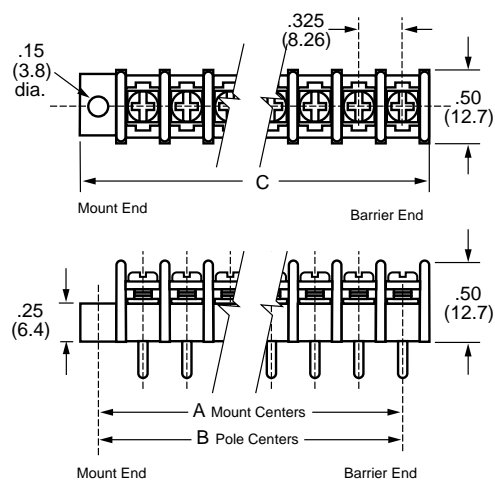

#### CB1000 Series

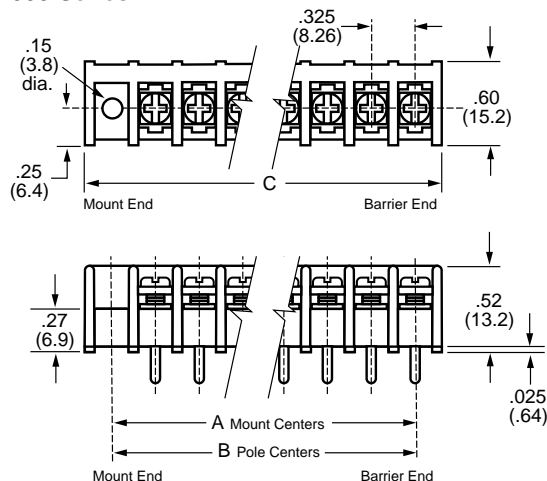

Poles	MOUNTING ENDS ONLY		BARRIER & MOUNTING ENDS B Pole Ctrs.	BARRIER ENDS ONLY C Length
	A Mount Ctrs.	C Length		
02	.98	1.37	.33	.72
03	1.30	1.69	.65	1.04
04	1.63	2.02	.98	1.37
05	1.95	2.34	1.30	1.69
06	2.28	2.67	1.63	2.02
07	2.60	2.99	1.95	2.34
08	2.93	3.32	2.28	2.67
09	3.25	3.64	2.60	2.99
10	3.58	3.97	2.93	3.32
11	3.90	4.29	3.25	3.64
12	4.23	4.62	3.58	3.97
13	4.55	4.94	3.90	4.29
14	4.88	5.27	4.23	4.62
15	5.20	5.59	4.55	4.94
16	5.53	5.92	4.88	5.27
17	5.85	6.24	5.20	5.59
18	6.18	6.57	5.53	5.92
19	6.50	6.89	5.85	6.24
20	6.83	7.22	6.18	6.57
21	7.15	7.54	6.50	6.89
22	7.48	7.87	6.83	7.22
23	7.80	8.19	7.15	7.54
24	8.13	8.52	7.48	7.87
25	8.45	8.84	7.80	8.19
26	8.78	9.17	8.13	8.52
27	9.10	9.49	8.45	8.84
28	9.43	9.82	8.78	9.17
29	9.75	10.14	9.10	9.49
30	10.08	10.47	9.43	9.82
31	10.40	10.79	9.75	10.14
32	10.73	11.12	10.08	10.47
33	11.05	11.44	10.40	10.79
34	11.38	11.77	10.73	11.12
35			11.05	11.44
36			11.38	11.77

\* Dimensions in inches. To convert to millimeters, multiply by 25.4.

## Part Numbering System

Series	Terminal Style	Base/End	Poles	Screw Options	Options
<b>A n</b> <b>CB n</b>	<b>n n</b>	<b>n</b>	<b>n n</b>	<b>n n n n</b>	<b>n n n n</b>
<b>A1</b> - standard barrier <b>CB1</b> - closed barrier	<b>02</b> - printed circuit <b>03</b> - non feed-thru <b>04</b> - wire wrap tail <b>07</b> - extended pin	<b>1</b> - mount end <b>2</b> - barrier end	<b>02 to 36</b> <b>02 to 34</b> on mount end base	<b>Blank</b> - std. screws <b>03</b> - stainless steel <b>07</b> - steel SEMS & washer (not available with hardware options) <b>CA</b> - standard captive screw <b>07CA</b> - SEMS captive	<b>AB &amp; DR</b> - angle mts. (A1 only-pg 6) <b>B1 to B9</b> - .187" QC (all positions) <b>EB</b> - exit back terminals on CB1 w/07 screw option only <b>JA, JB &amp; JC</b> - barrier jumpers <b>L1 to L6</b> marking options (pg 23) <b>LT1 to LT6</b> marking options (CB1 only-pg 23) <b>MP &amp; MT</b> - mounting plates (pg 6) <b>R26 &amp; R45</b> - right angle bends (A1 only-pg 6)

## Terminal Styles

Inches (Millimeters)

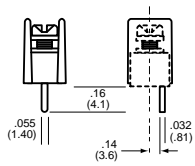

**02**  
Circuit Board



**03**  
Non Feed-Thru

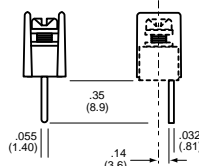

**04**  
Wire Wrap Tail

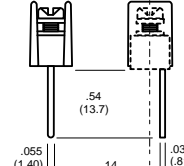

**07**  
Extended Pin

## CB1 Terminal Exit Options Tail length is .025" shorter on exit bottom terminals Inches (Millimeters)

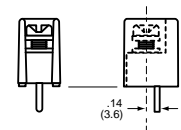

Exit Rear (std.)

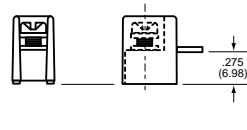

EB  
Exit Back

## Screw Options Wire ready screws standard on all terminal styles



Standard  
Zinc Plated Steel



**03**  
Stainless Steel



**07**  
Steel SEMS Zinc Plated

## Hardware Options (Bulk ordering part numbers are in parentheses.)

### Jumpers

Quick Connects Blade Width B = .187". (For other orientations, contact factory.)

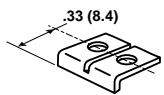

**JA (JA1-XX)**

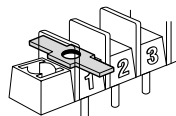

**B1 (1B1) \***

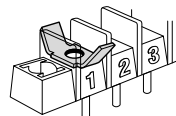

**B2 (1B2) \***

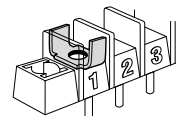

**B3 (1B3) \***

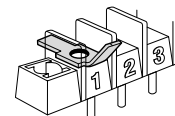

**B4 (1B4) \***

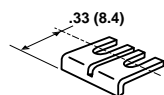

**JB (JB1-XX)**

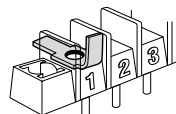

**B5 (1B5) \***

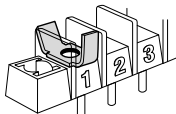

**B6 (1B6) \***

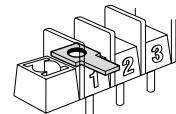

**B7 (1B7)**

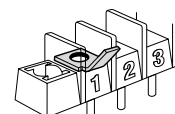

**B8 (1B8)**

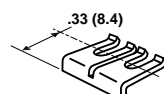

**JC (JC1-XX)**

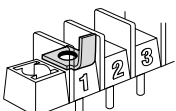

**B9 (1B9)**

\* N/A on CB1 Series.

Continued

# MAGNUM®

## Series A1000 & CB1000

### Single Row Terminal Blocks *Continued*

## Mounting Options Inches (Millimeters)

#### Right Angle Bends (A1 only)

Right angle terminals are offered on the A1000 Series. Configurations are defined in these dimensions: X = pin extension beyond the block base; Z = length from block base to centerline of the terminal tip. Standard bends consist of the X and Z dimensions shown in the chart. Specify by adding the selected Bend Option Code to the terminal part no.

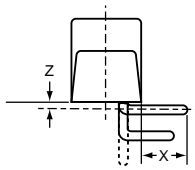

Bend Option Code	X (minimum)	Z
R26 (04 terminal only)	.14	.09
R45 (07 terminal only)	.33	.09

Dimensions in inches. To convert to millimeters, multiply by 25.4.

#### Angle Brackets (A1 only)

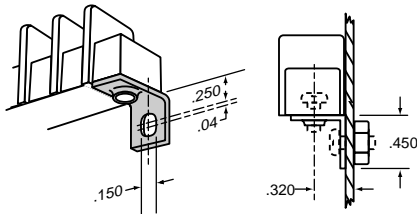

#### Option AB

Angle brackets enable block to be fastened at right angles to normal mount position. Bulk part no. **1AB**.

#### Drilled Right Angle (A1 only)

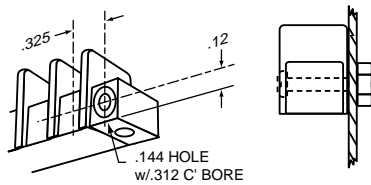

#### Option DR

Counterbored holes across mount ends of block enable fastening with two screws at right angles to normal mount position.

#### Mounting Plates

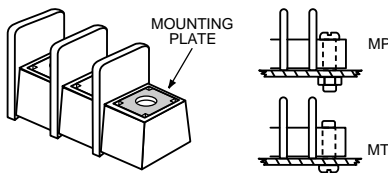

#### Options MP & MT

**MP** Metal inserts with .150" dia. hole accept #6 screw. **MT** Metal inserts with tapped hole accept #6-32 screw. Bulk Part Nos. **1MP & 1MT**.

## Series A2000, LP2000 & CB2000 Single Row Terminal Blocks

### SPECIFICATIONS

**Rating:** A2: 30A, 300V\*  
 LP2: 30A, 150V\*  
 CB2: 30A, 300V\*

**Center Spacing:** .375" or 3/8" (9.52 mm)

**Wire Size:** #12-22 AWG CU

**Screw Size:** #6-32 zinc plated phillslot

**Torque Rating:** 9 in.-lb. max.

**Base:** Standoffs standard for easy flux washing

**Distance Between Barriers:** .32" (8.1 mm)

**Recommended PCB Hole Diameter:** .076" (1.93 mm);  
 .062" (1.59 mm) on .045" terminals.

**Operating Temperature:** 105°F (221°F) max., -40°C (-40°F) min.

**Molded Material:** Black, UL Rated 94VO Thermoplastic

**Breakdown Voltage:** 3400V rms (A2 & LP2); 4100V rms (CB2).

**Approvals:** UL E62622; CSA LR15364; IEC Compliance;  
 CE Certified



### A2000 & LP2000 Series

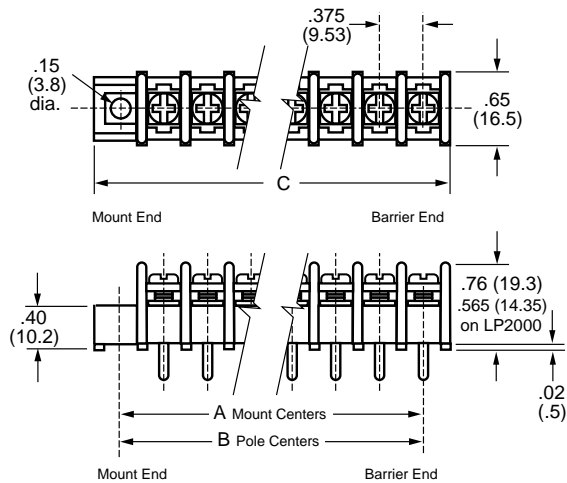

### CB2000 Series

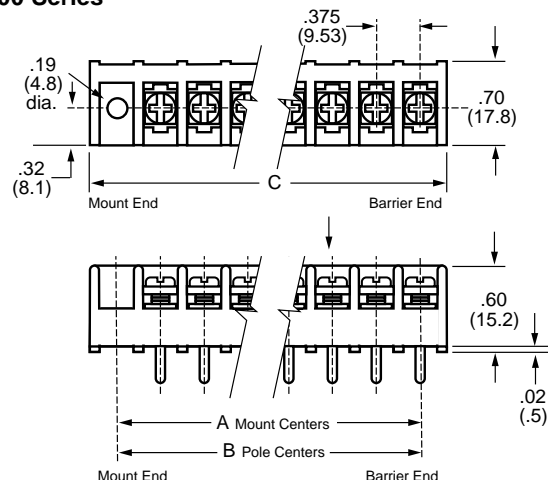

Poles	MOUNTING ENDS ONLY		BARRIER & MOUNTING ENDS B Pole Ctrs.	BARRIER ENDS ONLY C Length
	A Mount Ctrs.	C Length		
02	1.13	1.56	.38	.81
03	1.50	1.93	.75	1.18
04	1.88	2.30	1.13	1.56
05	2.25	2.68	1.50	1.93
06	2.63	3.06	1.88	2.31
07	3.00	3.43	2.25	2.68
08	3.38	3.81	2.63	3.06
09	3.75	4.18	3.00	3.43
10	4.13	4.56	3.38	3.81
11	4.50	4.93	3.75	4.18
12	4.88	5.31	4.13	4.56
13	5.25	5.69	4.50	4.93
14	5.63	6.06	4.88	5.31
15	6.00	6.43	5.25	5.68
16	6.38	6.81	5.63	6.06
17	6.75	7.18	6.00	6.43
18	7.13	7.56	6.38	6.81
19	7.50	7.93	6.75	7.18
20	7.88	8.31	7.13	7.56
21	8.25	8.68	7.50	7.93
22	8.63	9.06	7.88	8.31
23	9.00	9.43	8.25	8.68
24	9.38	9.81	8.63	9.06
25	9.75	10.18	9.00	9.43
26	10.13	10.56	9.38	9.81
27	10.50	10.93	9.75	10.18
28	10.88	11.31	10.13	10.55
29	11.25	11.68	10.50	10.93
30	11.63	12.05	10.88	11.31
31			11.25	11.68
32			11.63	12.05

\* Dimensions in inches. To convert to millimeters, multiply by 25.4.

# MAGNUM

## Series A2000 & LP2000 Single Row Terminal Blocks

### Part Numbering System

Series	Terminal Style	Base/End (Views pg. 9)	Poles	Screw Options	Options
<b>A2</b> - standard barrier <b>LP2</b> - low profile barrier	<b>01</b> - handwired <b>02</b> - printed circuit <b>03</b> - non feed-thru <b>04</b> - wire wrap tail <b>05</b> - extended handwired <b>06</b> - handwired <b>07</b> - extended pin <b>08</b> - printed circuit <b>09</b> - .250 QC w/o insulated base <b>10</b> - .187 QC <b>14</b> - printed circuit <b>19</b> - .250 QC with insulated base	<b>0</b> - flat base/molded mount end <b>1</b> - flat base/mnt. end <b>2</b> - flat base/barrier end <b>3</b> - insulator base/mnt. end <b>4</b> - insulator base/barrier end <b>5</b> - closed base/mount end <b>6</b> - closed base/molded mount end <b>9</b> - insulator base/molded mount end	<b>02 to 32</b> <b>02 to 30</b> on mount end base	<b>Blank</b> - std. screw <b>00</b> - screws shipped bulk <b>03</b> - stainless steel <b>04</b> - brass nickel plated <b>07</b> - steel SEMS (not available with hardware options) <b>09</b> - brass SEMS nickel plated (not available with hardware options) <b>CA</b> - captive screw <b>03CA</b> - stainless steel captive <b>04CA</b> - brass captive <b>07CA</b> - SEMS captive <b>09CA</b> - brass SEMS captive <b>07WR</b> - steel SEMS wire ready (not available on LP2)	<b>AB</b> - angle mnt. options (pg 10) <b>A1 to A9</b> - .250" QC <b>B1 to B9</b> - .187" QC <b>DR</b> - drilled right angle (pg 10) <b>JA, JB &amp; JC</b> - barrier jumpers <b>L1 to L6</b> marking options (pg 23) <b>MP, MP8 &amp; MT</b> mounting plates (pg 10) <b>OJ2 &amp; OJ4</b> - over barrier jumpers (not available w/covers) <b>RC</b> - retaining clips (pg 10) <b>R30 to R77</b> - right angle bends (pg 10) <b>SO</b> - stand off insulators (pg 10) <b>S1</b> - solder lug/flat

Base/End Note: 0, 6, 9 styles not available with covers. 3, 4, 9 Styles not available with 02, 03, 06, 08, 09 & 14 terminals. 5 & 6 Styles only available with 03 terminals.

### Terminal Styles

Inches (Millimeters)

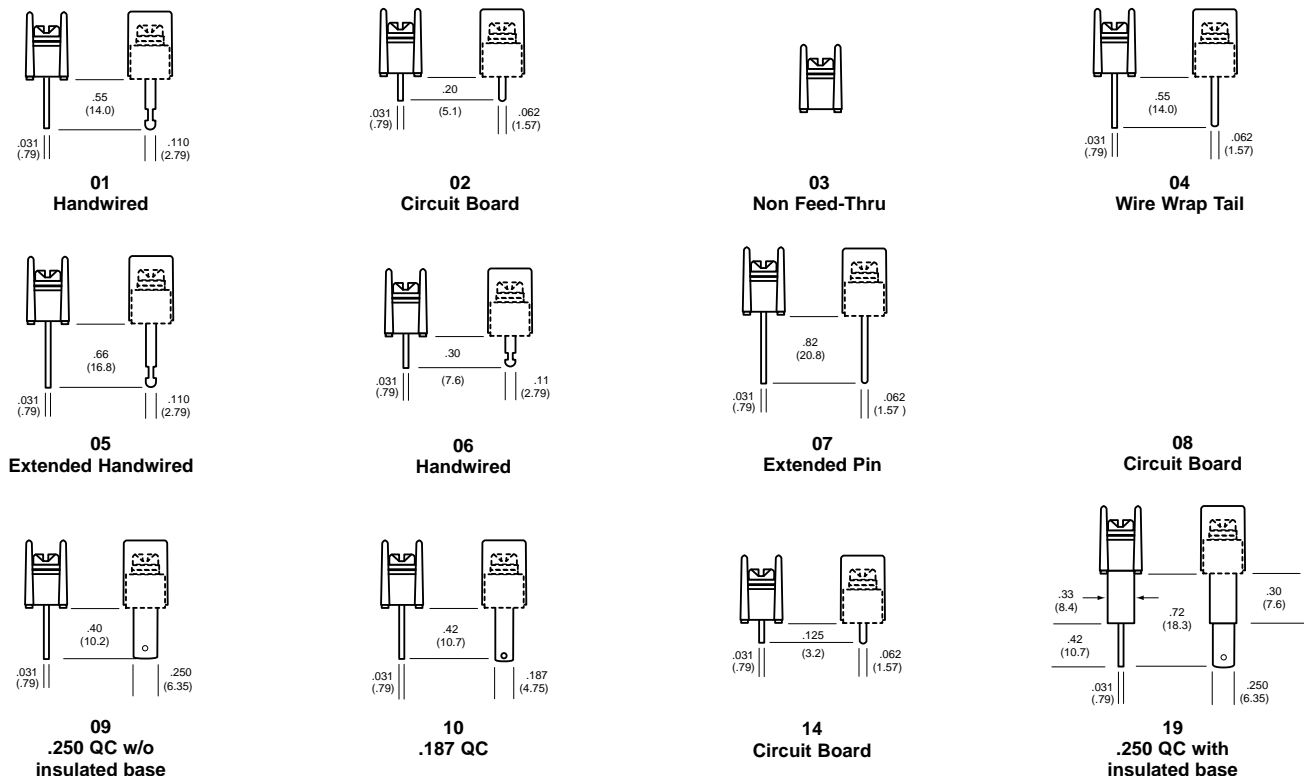



## Screw Options



**Standard**  
Zinc Plated Steel



**03**  
Stainless Steel



**04**  
Brass  
Nickel Plated



**07**  
Steel SEMS



**09**  
Brass SEMS  
Nickel Plated



**07WR**  
Wire Ready  
(A2 only)

## Hardware Options (Bulk ordering part numbers are in parentheses.)

Inches (Millimeters)

### Solder Lugs

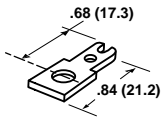

**S1**  
(2S1)

### Jumpers

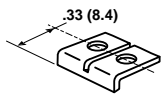

**JA**  
(JA2-XX)

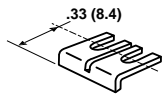

**JB**  
(JB2-XX)

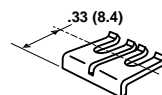

**JC**  
(JC2-XX)



**OJ2**



**OJ4**

### Quick Connects

Blade Width A = .250" Blade Width B = .187"

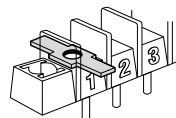

**A1 & B1**  
(2A1 & 2B1)

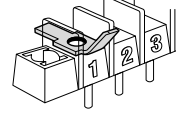

**A4 & B4**  
(2A4 & 2B4)

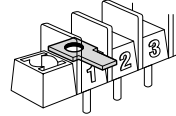

**A7 & B7**  
(2A7 & 2B7)

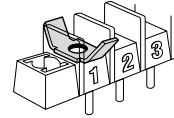

**A2 & B2**  
(2A2 & 2B2)

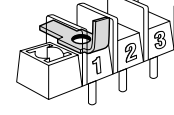

**A5 & B5**  
(2A5 & 2B5)

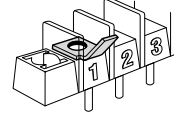

**A8 & B8**  
(2A8 & 2B8)

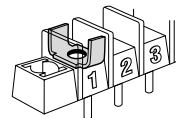

**A3 & B3**  
(2A3 & 2B3)

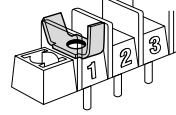

**A6 & B6**  
(2A6 & 2B6)

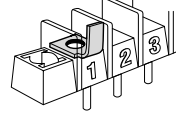

**A9 & B9**  
(2A9 & 2B9)

### Base/End Options

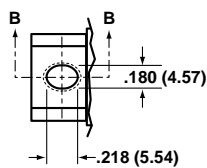

SECTION A-A

0, 6 & 9 Mount Ends

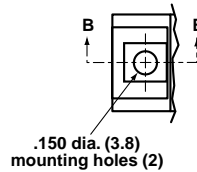

.150 dia. (3.8)  
mounting holes (2)

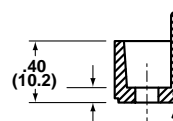

SECTION B-B

1, 3 & 5 Mount Ends

# MAGNUM®

## Series A2000 & LP2000

### Single Row Terminal Blocks *Continued*

## Mounting Options

### Right Angle Bends (A2, LP2 only)

Right angle terminals are offered on the A2000 & LP2000 Series. Configurations are defined in these dimension: X = pin extension beyond the block base; Z = length from block base to centerline of the terminal tip. Standard bends consist of the X and Z dimensions shown in the chart. Specify by adding the selected Bend Option Code to the terminal part no.

### 07 Terminal Bend Configurations

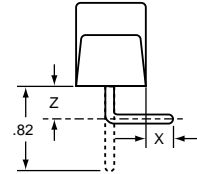

### 04 Terminal Bend Configurations

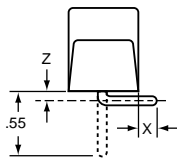

Bend Option Code	X (minimum)	Z	Available w/insulator base
R30	-.04	.28	No
R35	.01	.23	No
R36	.02	.22	No
R39	.05	.19	No
R42	.08	.16	No
R46	.12	.12	No
R48	.14	.10	No
R50	.16	.08	No

Bend Option Code	X (minimum)	Z	Available w/insulator base
R30	-.04	.55	Yes
R35	.01	.50	Yes
R36	.02	.49	Yes
R42	.08	.43	Yes
R46	.12	.39	Yes
R50	.16	.35	No
R53	.19	.32	No
R66	.32	.19	No
R69	.35	.16	No
R75	.41	.10	No
R77	.43	.08	No

Dimensions in inches. To convert to millimeters, multiply by 25.4.

### Angle Brackets (A2, LP2 only)

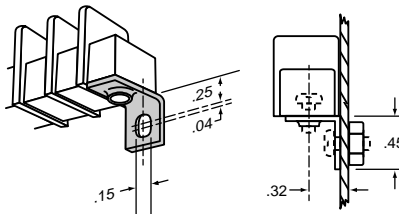

### Drilled Right Angle (A2, LP2 only)

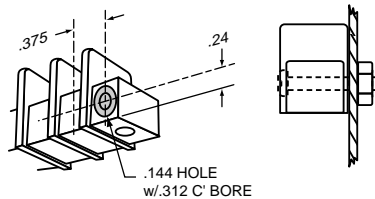

### Option AB

Angle brackets enable block to be fastened at right angles to normal mount position. Bulk part no. **2AB**.

### Option DR

Counterbored holes across mount ends of block enable fastening with two screws at right angles to normal mount position.

### Mounting Plates

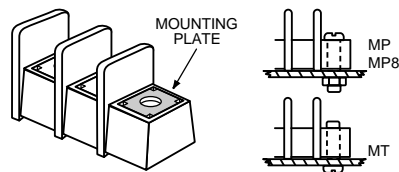

### Options MP, MP8 & MT

**MP** Metal inserts with .150" dia. hole accept #6 screw. **MP8** Metal inserts with .187" dia. hole accept #8-32 screw. **MT** Metal inserts with tapped hole accept #6-32 screw.

### Standoffs

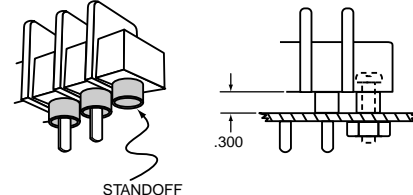

### Option SO

Standoff mounts are tubes molded to the mounting positions. Available with insulator bases only.

### Retaining Clip

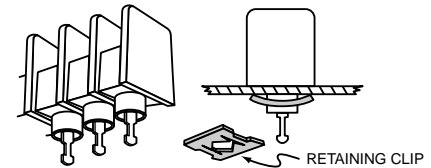

### Option RC

Use on standoff tubes. Fit panels up to .125" thick. Two clips for every five positions. Supplied unassembled. Bulk Part No. **H541**.

**Series CB2000**  
Single Row Terminal Blocks

**Part Numbering System**

Series	Terminal Style	Base/End	Poles	Screws	Options
<b>CB2</b>	<b>01</b> - handwired <b>02</b> - circuit board <b>03</b> - non feed-thru <b>07</b> - extended pin <b>14</b> - circuit board <b>22</b> - dual tail circuit board	<b>1</b> - mount end <b>2</b> - barrier end	<b>02 to 32</b> <b>02 to 30</b> on mount end base	<b>07</b> - steel SEMS standard <b>09</b> - brass SEMS nickel plated <b>CA</b> - captive screw <b>07CA</b> - SEMS captive	<b>AB</b> - angle mounting brackets (pg 12) <b>A7 to A9</b> - .250" QC <b>B7 to B9</b> - .187" QC <b>EB</b> - exit back terminals <b>EF</b> - exit front terminals <b>JA, JB &amp; JC</b> - barrier jumpers <b>L1 to L6</b> marking options (pg 23) <b>LT1 to LT6</b> marking options (pg 23) <b>OJ2 &amp; OJ4</b> - over barrier jumpers <b>MP, MP8, MT &amp; MT8</b> mtg. plates (pg 12) <b>S1</b> - solder lug/flat

**Terminal Styles** Inches (Millimeters)

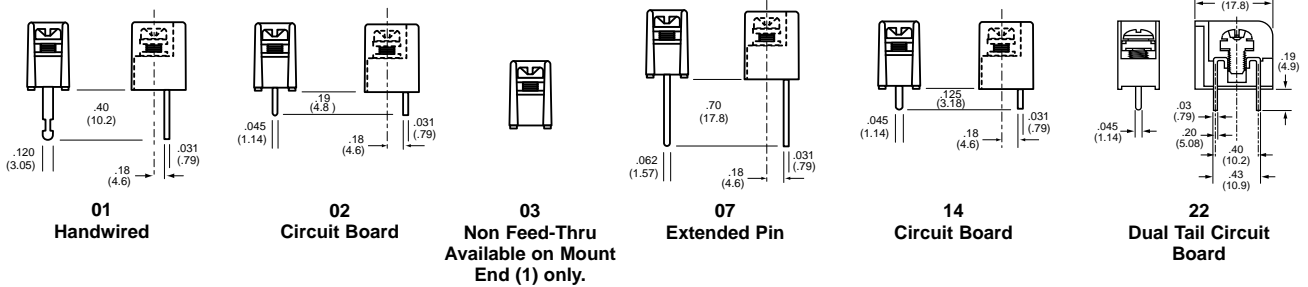

**CB2 Terminal Exit Options** Inches (Millimeters)

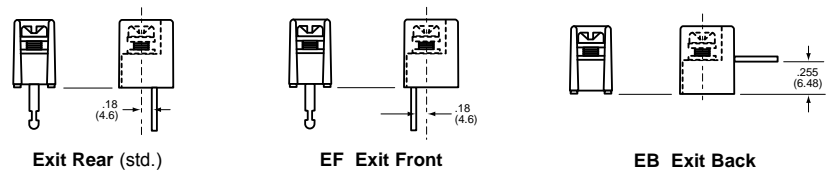

**Screw Options** Wire ready screws standard on all terminal styles

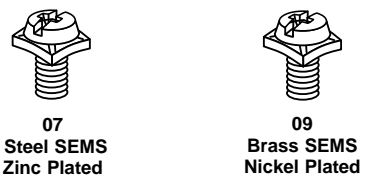

# MAGNUM®

## Series CB2000 Single Row Terminal Blocks *Continued*

### Hardware Options (Bulk ordering part numbers are in parentheses.) Inches (Millimeters)

<p><b>Solder Lugs</b></p> <p><b>S1</b></p>	<p><b>Jumpers</b></p> <p><b>JA</b> (JA2-XX)</p> <p><b>JB</b> (JB2-XX)</p> <p><b>JC</b> (JC2-XX)</p>	<p><b>OJ2</b></p> <p><b>OJ4</b></p>	<p><b>Quick Connects</b> Blade Width A = .250". Blade Width B = .187".</p> <p><b>A7 &amp; B7</b> (2A7 &amp; 2B7)</p> <p><b>A8 &amp; B8</b> (2A8 &amp; 2B8)</p> <p><b>A9 &amp; B9</b> (2A9 &amp; 2B9)</p>
--	---	-------------------------------------	--

### Mounting Options Inches (Millimeters)

**Right Angle Mounting Bracket**

- Mounts blocks on PC boards at a right angle.**
- Protects solder joints.
  - Recommended for all EB (Exit Back) PCB terminal blocks.
  - Bracket snaps securely on block (no hardware required).
  - Minimum strip length (end positions are usable).
  - Mount with #6-32 or #8-32 screws (not supplied).

**Option AB**

**Mounting Plates**

**MP**  
**MP8**

**MT**  
**MT8**

- Options MP, MP8, MT & MT8**
- MP** Metal inserts with .150" dia. hole accept #6 screw. **MP8** Metal inserts with .187" dia. hole accept #8-32 screw. **MT** Metal inserts with tapped hole accept #6-32 screw. **MT8** Metal inserts with tapped hole accept #8-32 screw.



## Series A3000, LP3000 & CB3000

### Single Row Terminal Blocks

#### SPECIFICATIONS

**Rating:** A3: 30A, 600V\*  
 LP3: 30A, 150V  
 CB3: 30A, 600V

**Center Spacing:** .437" or 7/16" (11.10 mm)

**Wire Size:** #12-22 AWG CU

**Screw Size:** #6-32 zinc plated phillslot screws.

**Torque Rating:** 9 in.-lb. max.

**Base:** Standoffs standard for easy flux washing.

**Distance Between Barriers:** .32" (8.1 mm)

**Recommended PCB Hole Diameter:** .076" (1.93 mm);  
 .062" (1.59 mm) on .045" terminals

**Operating Temperature:** 105°F (221°F) max., -40°C (-40°F) min.

**Molded Material:** Black, UL Rated 94VO Thermoplastic

**Breakdown Voltage:** 3500V rms (A3 & LP3); 8200V rms (CB3)

**Approvals:** UL E62622; CSA LR15364; IEC Compliance, CE Certified

\*30A Rating achieved with a #10 copper wire crimped to a ring terminal;  
 20 Rating without ring terminal.

A31940707WR

LP30110507

CB31420807



Poles	MOUNTING ENDS ONLY		BARRIER & MOUNTING ENDS B Pole Ctrs.	BARRIER ENDS ONLY C Length
	A Mount Ctrs.	C Length		
02	1.31	1.73	.43	.98
03	1.75	2.17	.87	1.43
04	2.18	2.61	1.31	1.87
05	2.62	3.05	1.75	2.31
06	3.06	3.48	2.18	2.75
07	3.50	3.92	2.62	3.18
08	3.93	4.36	3.06	3.62
09	4.37	4.80	3.50	4.06
10	4.81	5.23	3.93	4.50
11	5.25	5.67	4.37	4.93
12	5.68	6.11	4.81	5.37
13	6.12	6.55	5.25	5.81
14	6.56	6.98	5.68	6.25
15	7.00	7.42	6.12	6.68
16	7.43	7.86	6.56	7.12
17	7.87	8.30	7.00	7.56
18	8.31	8.73	7.43	8.00
19	8.75	9.17	7.87	8.43
20	9.18	9.60	8.31	8.87
21	9.62	10.05	8.50	9.31
22	10.06	10.48	9.18	9.75
23	10.50	10.92	9.62	10.18
24	10.93	11.36	10.06	10.62
25	11.37	11.80	10.50	11.06
26	11.81	12.23	10.93	11.50
27			11.37	11.93
28			11.81	12.37

Dimensions in inches. To convert to millimeters, multiply by 25.4.

#### A3000 & LP3000 Series

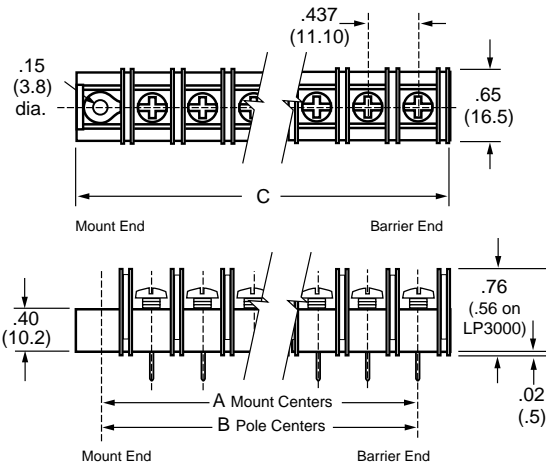

#### CB3000 Series

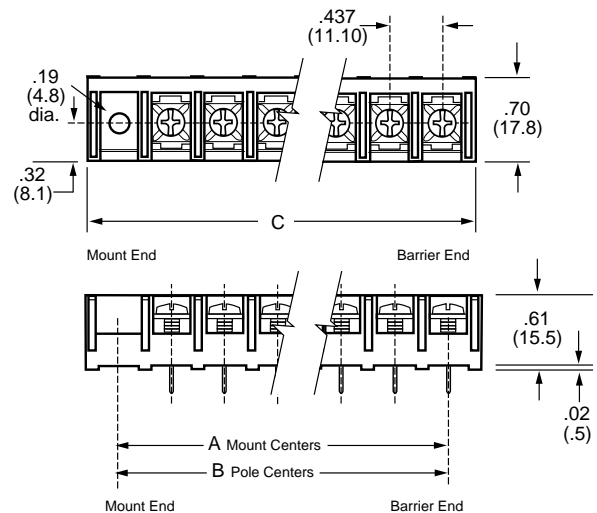

# MAGNUM®

## Series A3000 & LP3000 Single Row Terminal Blocks

### Part Numbering System

Series	Terminal Style	Base/End (Views pg. 15)	Poles	Screw Options	Options
<b>A3</b> - standard barrier <b>LP3</b> - low profile barrier	<b>01</b> - handwired <b>02</b> - printed circuit <b>03</b> - non feed-thru <b>04</b> - wire wrap tail <b>06</b> - handwired <b>07</b> - extended pin <b>08</b> - printed circuit <b>09</b> - .250 QC w/o insulated base <b>10</b> - .187 QC <b>14</b> - printed circuit <b>19</b> - .250 QC with insulated base	<b>1</b> - flat base/mnt. end <b>2</b> - flat base/barrier end <b>3</b> - insulator base/ mnt. end <b>4</b> - insulator base/ barrier end <b>5</b> - closed base/ mount end	<b>02 to 28</b> <b>02 to 26</b> on mount end base	<b>Blank</b> - std. screw <b>00</b> - screws shipped bulk <b>03</b> - stainless steel <b>04</b> - brass nickel plated <b>07</b> - steel SEMS zinc plated (not available with hardware options) <b>09</b> - brass SEMS nickel plated (not available with hardware options) <b>03CA</b> - stainless steel captive <b>04CA</b> - brass captive <b>07CA</b> - SEMS captive <b>09CA</b> - brass SEMS captive <b>07WR</b> - steel SEMS wire ready (N/A on LP3)	<b>AB</b> - angle mnt. options (pg 16) <b>A1 to A9</b> - .250" QC <b>B1 to B9</b> - .187" QC <b>DR</b> - drilled right angle (pg 16) <b>J201</b> - flat slip-on jumper <b>L1 to L6</b> marking options (pg 23) <b>MP, MP8 &amp; MT</b> mounting plates (pg 16) <b>OJ3 &amp; OJ4</b> - over barrier jumpers <b>RC</b> - retaining clips (pg 16) <b>R30 to R77</b> - right angle bends (pg 16) <b>SO</b> - stand off insulators (pg 16) <b>S1</b> - solder lug/flat

Base/End Note: 3, 4 styles not available with 02, 03, 06, 08, 09 & 14 terminals.  
5 Style only available with 03 terminals.

### Terminal Styles

Inches (Millimeters)

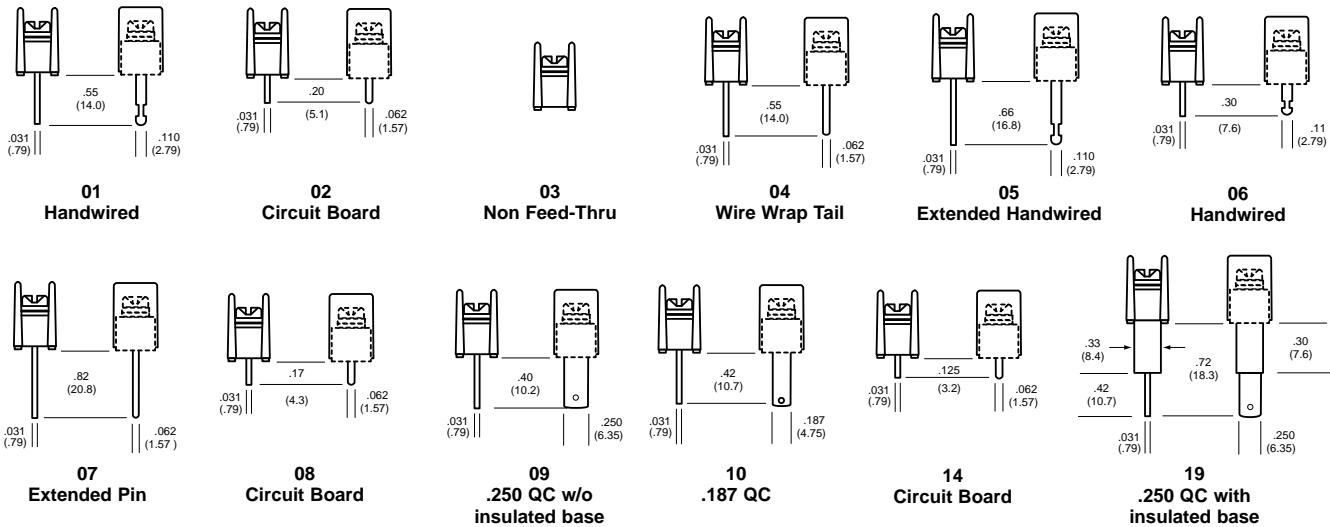

### Screw Options

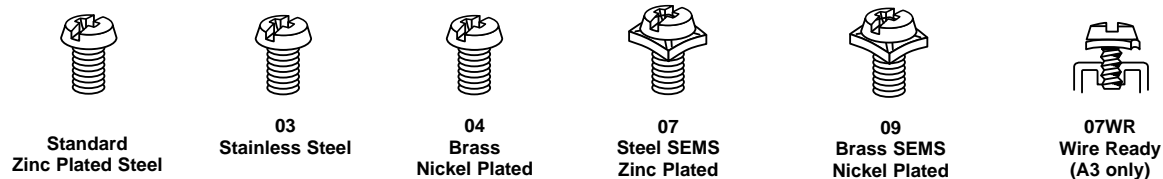

**Hardware Options** (Bulk ordering part numbers are in parentheses.)

Inches (Millimeters)

**Solder Lugs**

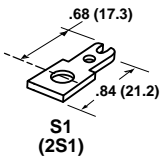

**Jumpers**

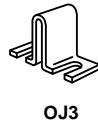
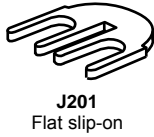

**Quick Connects**

Blade Width A = .250" Blade Width B = .187"

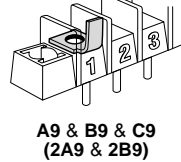
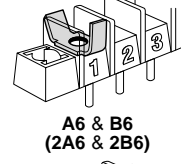
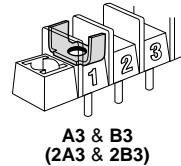
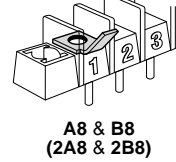
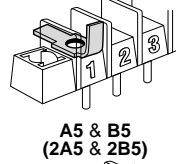
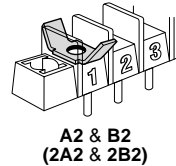
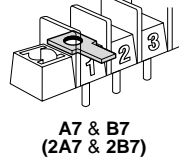
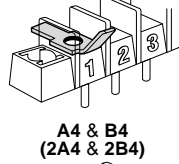
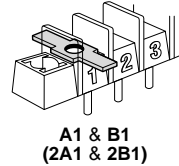

**Base/End Options**

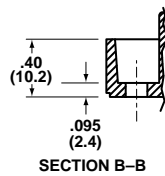
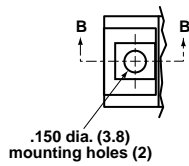

1, 3 & 5 Mount Ends

# MAGNUM®

## Series A3000 & LP3000

### Single Row Terminal Blocks *Continued*

### Mounting Options

#### Right Angle Bends (A3, LP3 only)

Right angle terminals are offered on the A3000 & LP3000 Series. Configurations are defined in these dimensions: X = pin extension beyond the block base; Z = length from block base to centerline of the terminal tip. Standard bends consist of the X and Z dimensions shown in the chart. Specify by adding the selected Bend Option Code to the terminal part no.

#### 04 Terminal Bend Configurations

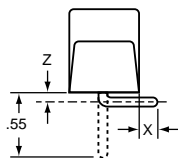

Bend Option Code	X (minimum)	Z	Available w/insulator base
R30	-.04	.28	No
R35	.01	.23	No
R36	.02	.22	No
R39	.05	.19	No
R42	.08	.16	No
R46	.12	.12	No
R48	.14	.10	No
R50	.16	.08	No

#### 07 Terminal Bend Configurations

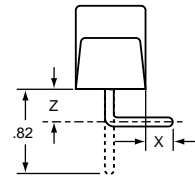

Bend Option Code	X (minimum)	Z	Available w/insulator base
R30	-.04	.55	Yes
R35	.01	.50	Yes
R36	.02	.49	Yes
R50	.16	.35	No
R53	.19	.32	No
R66	.32	.19	No
R69	.35	.16	No
R75	.41	.10	No
R77	.43	.08	No

Dimensions in inches. To convert to millimeters, multiply by 25.4.

#### Angle Brackets (A3, LP3 only)

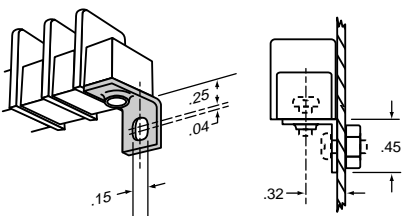

#### Option AB

Angle brackets enable block to be fastened at right angles to normal mount position. Bulk part no. **2AB**.

#### Drilled Right Angle (A3, LP3 only)

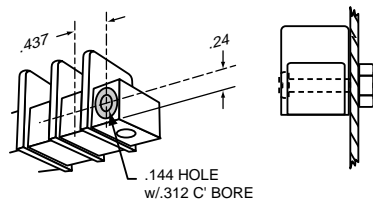

#### Option DR

Counterbored holes across mount ends of block enable fastening with two screws at right angles to normal mount position.

#### Mounting Plates

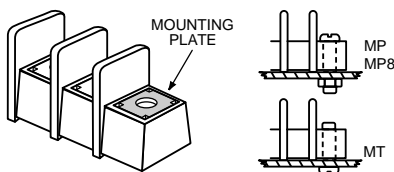

#### Options MP, MP8 & MT

**MP** Metal inserts with .150" dia. hole accept #6 screw. **MP8** Metal inserts with .187" dia. hole accept #8-32 screw. **MT** Metal inserts with tapped hole accept #6-32 screw.

#### Standoffs

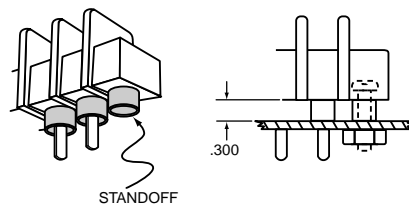

#### Option SO

Standoff mounts are tubes molded to the mounting positions. Available with insulator bases only.

#### Retaining Clip

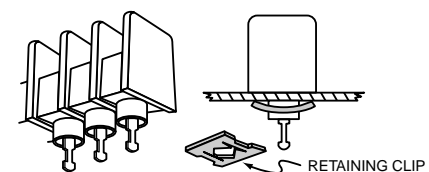

#### Option RC

Use on standoff tubes. Fit panels up to .125" thick. Two clips for every five positions. Supplied unassembled. Bulk Part No. **H541**.



**Series CB3000**  
Single Row Terminal Blocks

**Part Numbering System**

Series	Terminal Style	Base/End	Poles	Screws	Options
<b>CB3</b>	<b>nn</b>	<b>n</b>	<b>nn</b>	<b>nnnn</b>	<b>nnn</b>
<b>CB3</b> - closed back	<b>01</b> - handwired #6-32 screw <b>02</b> - circuit board #6-32 screw <b>03</b> - non feed-thru #6-32 screw <b>07</b> - extended pin #6-32 screw <b>14</b> - circuit board #6-32 screw <b>51</b> - handwired #8-32 screw <b>52</b> - circuit board #8-32 screw <b>53</b> - non feed-thru #8-32 screw <b>57</b> - extended pin #8-32 screw <b>64</b> - circuit board #8-32 screw	<b>1</b> - mount end <b>2</b> - barrier end <b>5</b> - closed base/ mount end	<b>02 to 28</b> <b>02 to 26</b> on mount end base	<b>07</b> - steel SEMS <b>09</b> - brass SEMS nickel plated <b>07CA</b> - SEMS captive	<b>AB</b> - angle mounting brackets (pg 18) <b>A7 to A9</b> - .250" QC <b>B7 to B9</b> - .187" QC <b>EB</b> - exit back terminals <b>EF</b> - exit front terminals <b>L1 to L6</b> marking options (pg 23) <b>LT1 to LT6</b> marking options (pg 23) <b>OJ3 &amp; OJ7</b> - over barrier jumpers <b>MP, MP8, MT &amp; MT8</b> mtg. plates (pg 18) <b>S1</b> - solder lug/flat
Base/End Note: 5 Style only available with 03 terminals.					

**Terminal Styles** Inches (Millimeters)

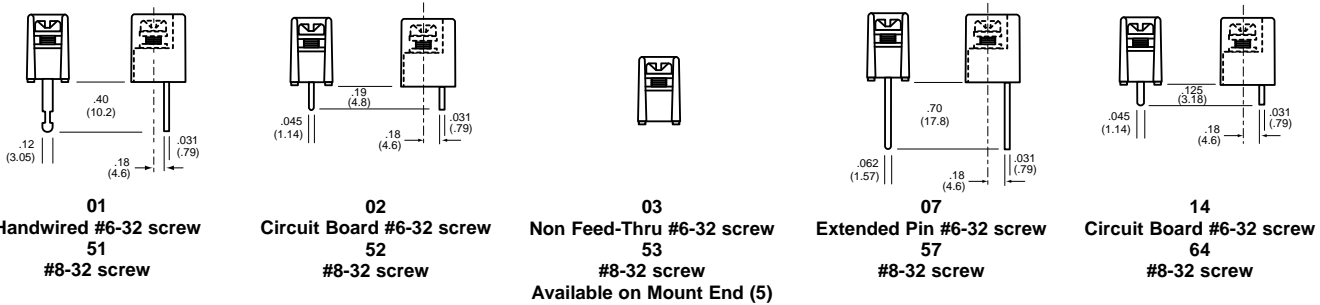

**CB3 Terminal Exit Options** Inches (Millimeters)

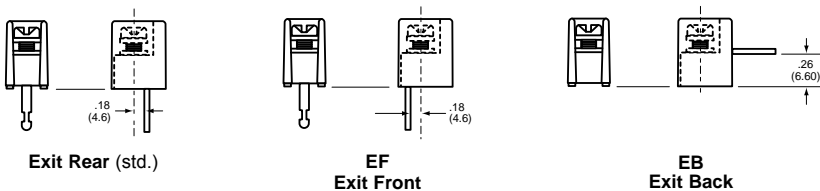

**Screw Options** Wire ready screws standard on all terminal styles

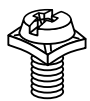

**07**  
Steel SEMS  
Zinc Plated

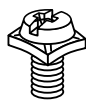

**09**  
Brass SEMS  
Nickel Plated

# MAGNUM<sup>®</sup>

## Series CB3000

### Single Row Terminal Blocks *Continued*

#### Hardware Options (Bulk ordering part numbers are in parentheses.)

Inches (Millimeters)

##### Solder Lugs

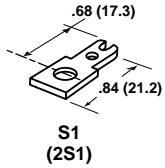

##### Jumpers

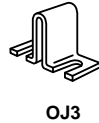
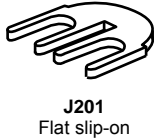

##### Quick Connects

Blade Width A = .250". Blade Width B = .187".

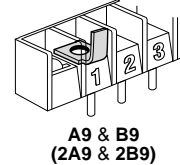
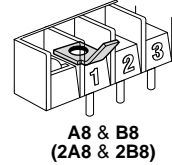
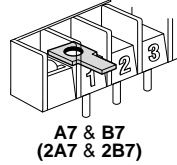

#### Mounting Options

Inches (Millimeters)

##### Right Angle Mounting Bracket

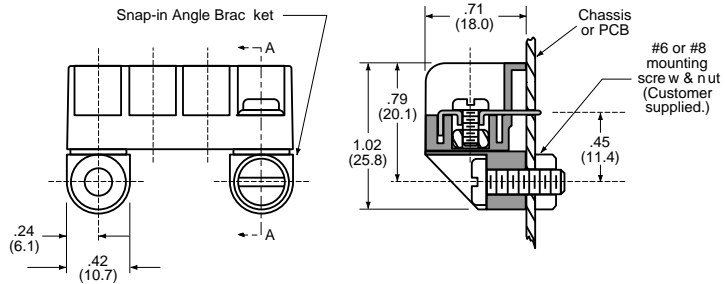
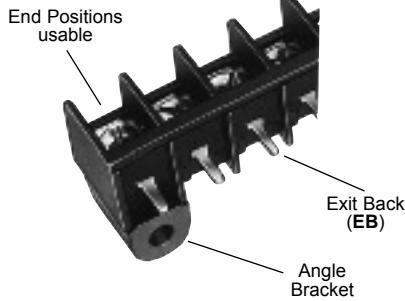

##### Mounts blocks on PC boards at a right angle.

- Protects solder joints.
- Recommended for all EB (Exit Back) PCB terminal blocks.
- Bracket snaps securely on block (no hardware required).
- Minimum strip length (end positions are usable).
- Mount with #6-32 or #8-32 screws (not supplied).

##### Mounting Plates

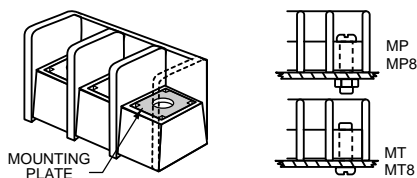

##### Options MP, MP8, MT & MT8

- MP** Metal inserts with .150" dia. hole accept #6 screw.
- MP8** Metal inserts with .187" dia. hole accept #8-32 screw.
- MT** Metal inserts with tapped hole accept #6-32 screw.
- MT8** Metal inserts with tapped hole accept #8-32 screw.

**Series A38 / B38**  
Single Row Terminal Blocks

**SPECIFICATIONS**

**Rating:** A38: 30A, 600V  
B38: 50A, 600V  
**Center Spacing:** .437" (11.10 mm)  
**Wire Size:** #10-22 AWG CU  
**Screw Size:** #8-32 Zinc Plated Steel  
**Torque Rating:** A38: 9 in-lb; B38: 15 in-lb  
**Distance Between Barriers:** .378" (9.60mm)  
**Operating Temperature:** 221°F (105°C)  
**Molded Material:** Black, UL Rated 94VO Thermoplastic  
**Breakdown Voltage:** 5000V rms  
**Recommended PCB Hole Diameter (A38):** .076" (1.93mm)  
**Approvals:** UL E62622; CSA LR15364; CE Certified

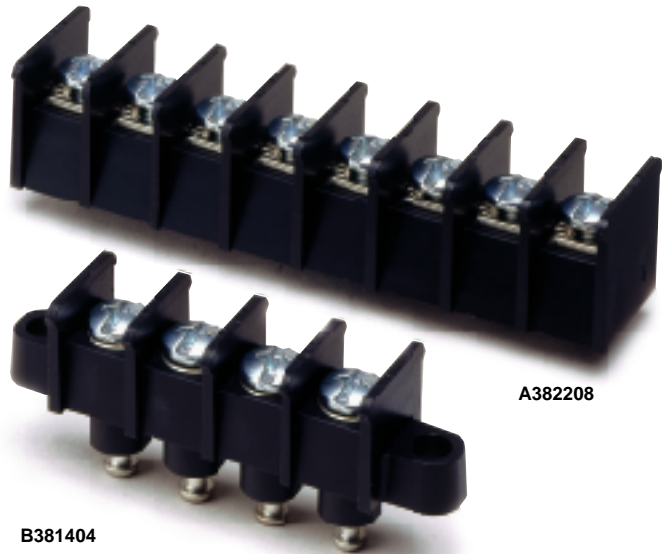
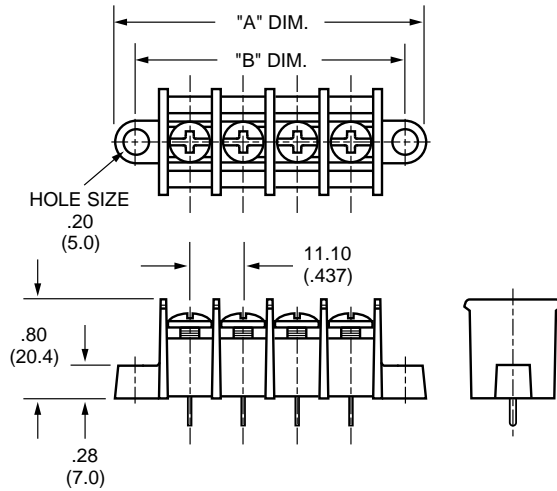

**TABLE A**

Poles	MOUNTING ENDS ONLY		BARRIER ENDS ONLY
	B Mount Ctrs.	"A" Dim. Length	"A" Dim. Length
02	1.31	1.67	0.93
03	1.75	2.10	1.37
04	2.19	2.54	1.81
05	2.62	2.98	4.05
06	3.06	3.41	2.68
07	3.50	3.85	3.12
08	3.93	4.29	3.56
09	4.37	4.72	3.99
10	4.81	5.16	4.43
11	5.24	5.60	4.87
12	5.68	6.04	5.30
13	6.12	6.47	5.74
14	6.56	6.91	6.18
15	6.99	7.35	6.61
16	7.43	7.78	7.05

\* Dimensions in inches. To convert to millimeters, multiply by 25.4.

**Series A38**



**Series B38**

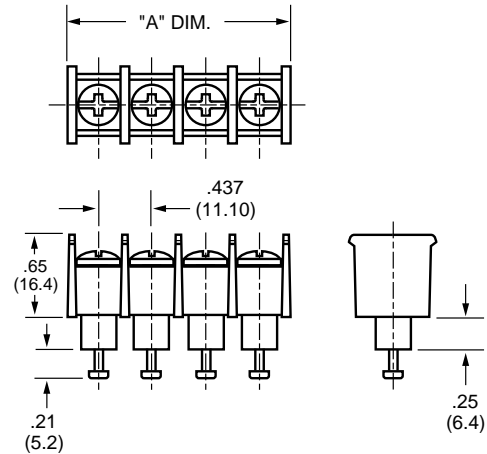

# MAGNUM®

## Part Numbering System

Series	Terminal Style	Base/End	# of Poles	Screw Options	Options
<b>A A A</b>	<b>n</b>	<b>n</b>	<b>n n</b>	<b>n n</b>	<b>n n</b>
	<ul style="list-style-type: none"> <li>1 - hand wired</li> <li>2 - pc tail</li> <li>7 - extended wire wrap</li> <li>8 - short pc tail</li> <li>9 - .250" QC male tab</li> </ul>	<ul style="list-style-type: none"> <li>1 - flat base, mount ends</li> <li>2 - flat base, barrier ends</li> <li>3 - insulator base* mount ends</li> <li>4 - insulator base* barrier ends</li> </ul> <p>*N/A on 2 &amp; 8 terminal styles.</p>	<b>02 to 16</b>	<ul style="list-style-type: none"> <li><b>Blank</b> - standard screw (steel zinc plated, philslot BHMS)</li> <li><b>04</b> - brass, nickel plated, philslot BHMS</li> <li><b>07</b> - steel, SEMS zinc plated philslot screw</li> <li><b>92</b> - steel, zinc plated slotted BHMS</li> <li><b>94</b> - brass, nickel plated slotted BHMS</li> </ul>	<ul style="list-style-type: none"> <li><b>L1 to L6</b> marking options (pg 23)</li> <li><b>RC</b> - retaining clips (pg 16)</li> <li><b>Covers</b> - (pg 24)</li> </ul>
<b>B A A</b>	<b>n</b>	<b>n</b>	<b>n n</b>	<b>n n</b>	<b>n n</b>
	<ul style="list-style-type: none"> <li>1 - long turret</li> <li>2 - short turret</li> <li>3 - screw terminal #6-32 screw top &amp; bottom)</li> <li>4 - stud (#8-32 screw top, #6-32 screw bottom)</li> <li>5 - double stud (#6-32 stud top &amp; bottom)</li> </ul>	<ul style="list-style-type: none"> <li>0 - flat base, mount ends</li> <li>4 - insulator base, barrier ends</li> <li>9 - insulator base mount ends</li> </ul>	<b>02 to 16</b>	<ul style="list-style-type: none"> <li><b>Blank</b> - standard screw steel zinc plated philslot BHMS)</li> <li><b>04</b> - brass, nickel plated, philslot BHMS</li> <li><b>32</b> - #6-32 zinc plated steel philslot BHMS*</li> <li><b>34</b> - #6-32 nickel plated brass philslot BHMS*</li> <li><b>92</b> - steel, zinc plated slotted BHMS</li> <li><b>94</b> - brass, nickel plated slotted BHMS</li> </ul>	<ul style="list-style-type: none"> <li><b>L1 to L6</b> marking options (pg 23)</li> <li><b>RC</b> - retaining clips (pg 16)</li> <li><b>Covers</b> - (pg 24)</li> </ul> <p>*Note: 32 &amp; 34 screws only available with 3 terminal style.</p>

## A38 Terminal Styles Wire ready screws standard

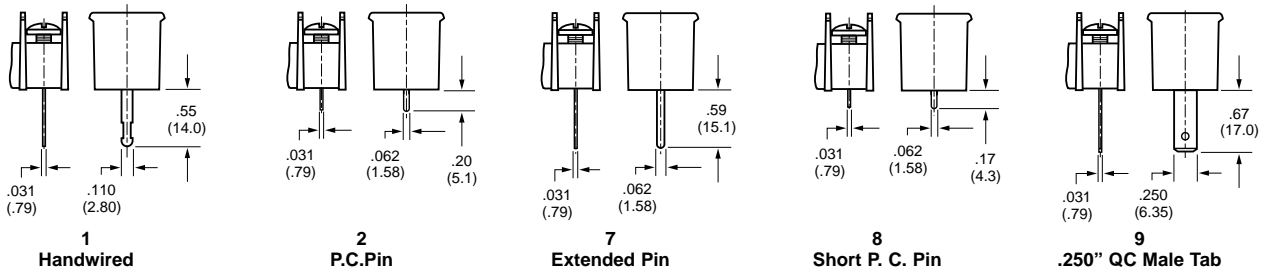

## B38 Terminal Styles

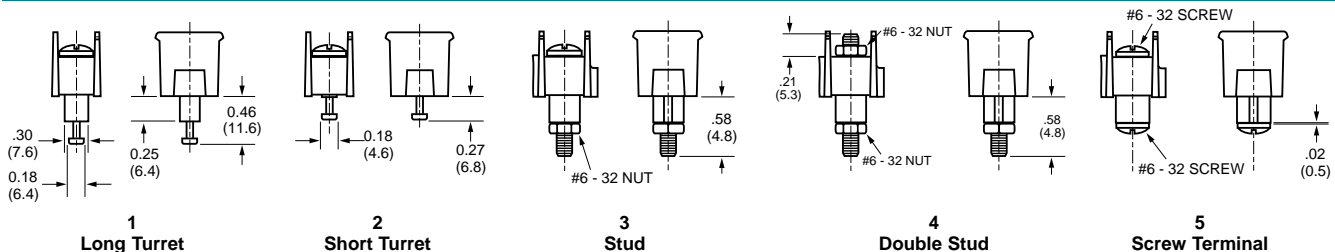

## Screw Options

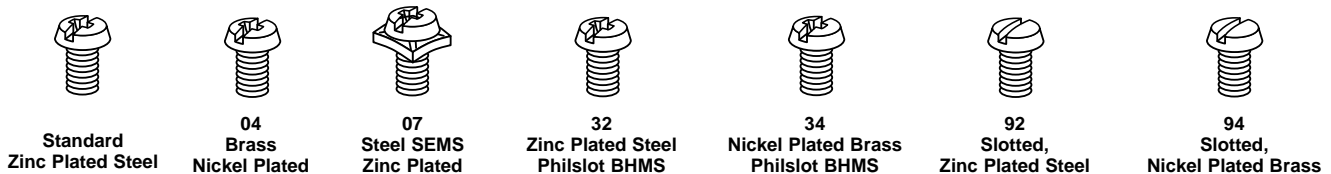



## Series A4000 & Series B4000

### Single Row Terminal Blocks

#### SPECIFICATIONS

**Rating:** See table.

**Center Spacing:** .562" or 9/16" (14.28 mm)

**Wire Size:** See rating table.

**Screw Size:** #8-32 or #10-32 zinc plated screws

**Torque Rating:** #8 screw size 16 in-lb. max; #10 screw size 20 in-lb. max.

**Distance Between Barriers:** .47" (11.9 mm)

**Operating Temperature:** 105°C (221°F) max., -40°C (-40°F) min.

**Molded Material:** Black, UL Rated 94VO Thermoplastic

**Hardware:** Bottom studs supplied with nuts assembled.

Cup washers are optional on bottom studs but are not recommended with ring terminals.

**Extended Hex Nuts:** Optional extended, slotted hex nuts enable easier installation and removal with hex wrench or screwdriver. Available in bulk for the #10-32 studs on Series A4953 blocks. Specify part no. F582 and quantity.

**Approvals:** UL E62622; CSA LR15364; CE Certified

#### RATING TABLE

Part Number	Terminal Top	Terminal Bottom	Wire Range CU	Rated Voltage	Rated Current*
A4003XX	# 8 Screw	#8 Stud	10-16 AWG	150V;	50 amps
A4011XX	# 8 Screw	Solder	10-16 AWG	600V;	35 amps
A4013XX	# 8 Screw	Solder	10-16 AWG	600V;	35 amps
A4021XX	# 8 Screw	.250 QC	10-16 AWG	600V;	35 amps
A4035XX	# 8 Screw	Closed	10-16 AWG	600V;	50 amps
A4041XX	#10 Screw	Solder	10-16 AWG	600V;	35 amps
A4051XX	#10 Screw	250 QC	10-16 AWG	600V;	35 amps
A4803XX	#10 Screw	#8 Stud	10-16 AWG	150V;	50 amps
A4813XX	#10 Screw	Solder Turret	10-16 AWG	600V;	35 amps
A4843XX	#10 Screw	#8 Screw	10-16 AWG	150V;	50 amps
A4953XX	#10 Stud	#10 Stud	10-16 AWG	150V;	50 amps
B4843XX	#10 Screw	#8 Screw	10-16 AWG	600V;	50 amps

\* All models 30A Max. with 10 AWG;

35-50A ratings with 8 AWG using ring or fork type terminals.

Note: 1. 50A rating achieved with #8 copper wire crimped to ring terminal.

2. Insulated ring terminal required for bottom termination on B4843XX.

Poles	A (in.) Mount Centers	B (in.) Length
2	1.69	2.12
3	2.25	2.68
4	2.81	3.24
5	3.37	3.80
6	3.93	4.36
7	4.50	4.93
8	5.06	5.34
9	5.62	6.05
10	6.18	6.61
11	6.74	7.17
12	7.31	7.74
13	7.87	8.30
14	8.43	8.86
15	8.99	9.44
16	9.55	9.98
17	10.12	10.55
18	10.68	11.11

\* Dimensions in inches. To convert to millimeters, multiply by 25.4.

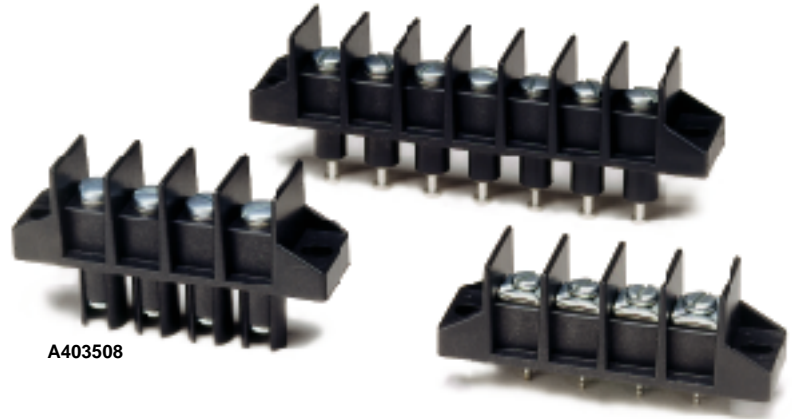

#### A4000 Series

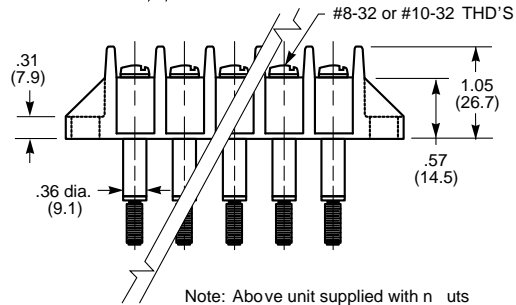
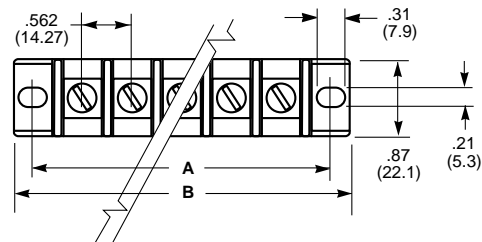

Note: Above unit supplied with nuts assembled. Cup washers are optional.

#### Optional Cup Washers Assembled

Available on A4003, A4803, A4843, A4953 & B4843.

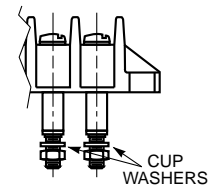

#### Reference Panel Cutout for 6 Position Block

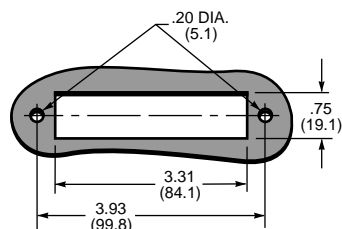

## Part Numbering System

Series	Terminal Style	Base/End	Poles	Screw Options	Options
<b>A</b> A4 - standard B4 - barrier	<b>n n</b> 00 - screw top; stud bottom 01 - screw top; solder bottom 02 - #8 screw top; .250 QC bottom 03 - screw top only 04 - #10 screw top; solder term. b. 05 - #10 screw top; .250 QC bottom 80 - screw top; stud bottom insulated base 81 - screw top; solder turret bottom 84 - screw top; screw bottom 95 - stud top; stud bottom	<b>n</b> 1 - flat base/ mount end 3 - insulator base/ mount end 5 - closed base/ mount end	<b>n n</b> 02 to 18	<b>n n</b> Blank - std. screw 00 - screws shipped bulk 04 - brass nickel plated 07 - steel SEMS zinc plated (not available with hardware options; not available on A4003, A4803, A4813, A4843, B4843)	<b>n n</b> A1 to A9 - .250" QC CW - cup washer J301 - flat slip-on jumper (2 position only) L1 to L6 marking options (pg 23) S1 & S2 - solder lugs/flat

## Terminal Styles

Inches (Millimeters)

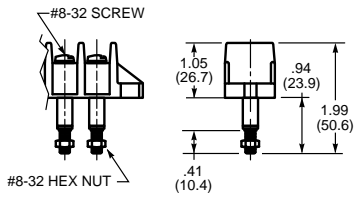

A4003XX

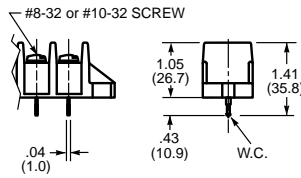

A4011XX (#8-32)  
A4041XX (#10-32)

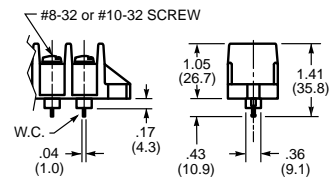

A4013XX (#8-32)  
A4043XX (#10-32)

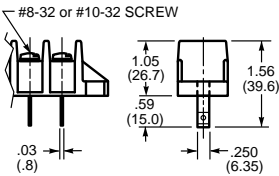

A4021XX (#8-32)  
A4051XX (#10-32)

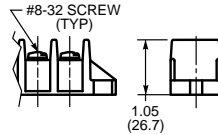

A4035XX

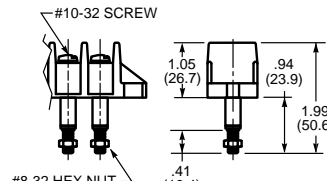

A4803XX

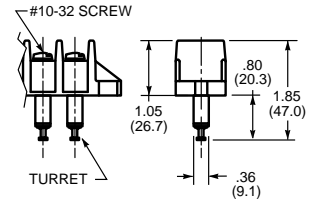

A4813XX

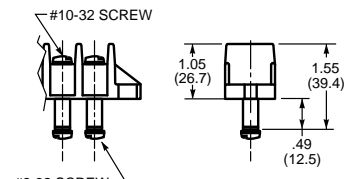

A4843XX

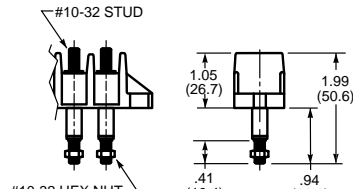

A4953XX

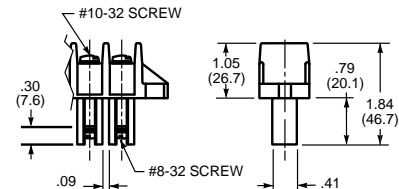

B4843XX

## Hardware Options (Bulk ordering part numbers are in parentheses.)

Inches (Millimeters)

### Solder Lugs

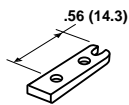

S1  
(2S1)

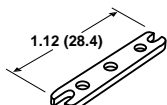

S2  
(2S2)

### Jumpers



J301

### Quick Connects Blade Width A = .250". (For other orientations, contact factory.)

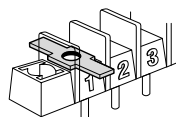

A1  
(4A1)

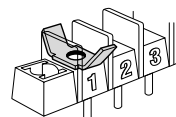

A2  
(4A2)

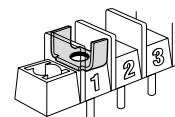

A3  
(4A3)

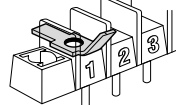

A4  
(4A4)

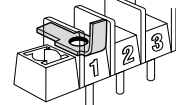

A5  
(4A5)



A6  
(4A6)

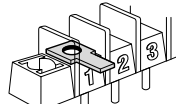

A7  
(4A7)

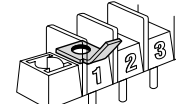

A8  
(4A8)

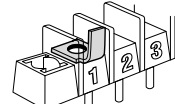

A9  
(4A9)

## All Series Marking Options Single Row Terminal Blocks

### Marking Options & Accessories

#### Standard Marking

Markings are applied directly to the sides of Series 1000, 2000, 3000, 4000 & 5000. Standard characters are white and 1/8" high. Factory may substitute 3/32" high characters.

Blocks to be marked on both sides require a different code for each side. Example: "L1" on one side of the block requires "L2" on the other side to ensure common terminal marking. Specify by adding suffix to part no.

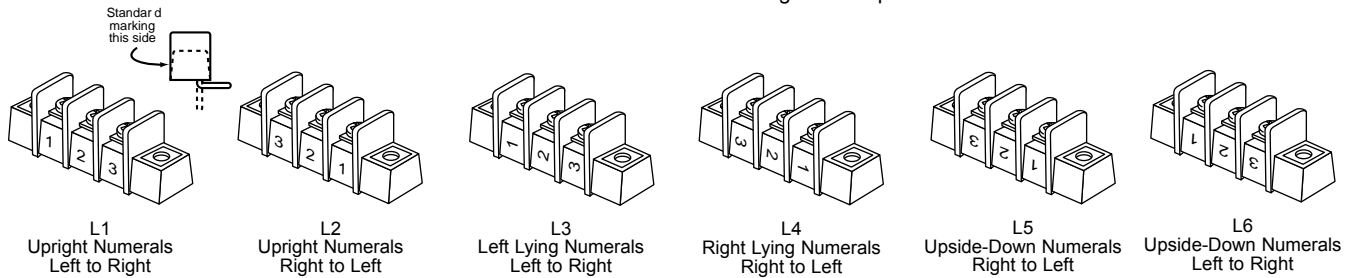

#### Special Marking

Special markings are available for Series 1000, 2000, 3000, 4000 & 5000 at an additional charge for preparation. Production charges for setup, handling and marking are the same as for standard marking and the same quantity discounts apply. Consult factory for price and delivery.

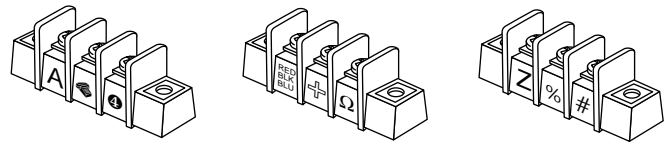

#### Closed Barrier Terminal Block Marking Options

- L1 & LT1 = Upright numerals, numbered from left to right
- L2 & LT2 = Upright numerals, numbered from right to left
- L3 = Left lying numerals, numbered from left to right
- L4 = Right lying numerals, numbered from right to left
- L5 & LT5 = Upside down numerals, numbered from right to left
- L6 & LT6 = Upside down numerals, numbered from left to right

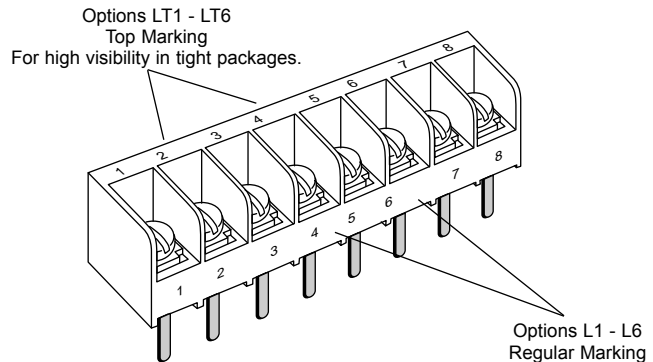

#### Marker Strips

Black marker strips with white numerals mount beneath the terminal blocks to clearly identify terminal and wire positions. Available with

forward or reverse markings, top or bottom of strip. If special markings are required, submit a drawing.

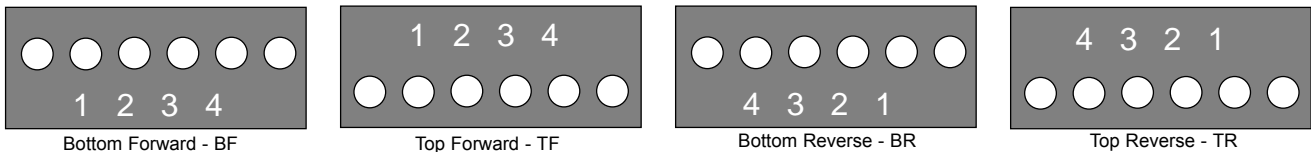

#### Series

M 6 n n

- MS1 - 1000 Series
- MS2 - 2000 Series
- MS3 - 3000 Series

#### Base

n

- 1 - mount end, feed thru
- 2 - barrier end, feed thru
- 3 - mount end, insulator tubes
- 4 - barrier end, insulator tubes
- 5 - mount end, non feed-thru

#### Poles

n n

- 02 to 36

#### Marking

n n

- BF - bottom forward
- TF - top forward
- BR - bottom reverse
- TR - top reverse

# MAGNUM®

## All Series Accessories

### Single Row Terminal Blocks Continued

## Cover Options - Single Row

#### Terminal Block Covers

Available for Series A1000, A2000, A3000, LP3000, CB2000 & CB3000. Three styles of thermoplastic covers are offered in yellow or black. Covers are ordered separately and supplied with two clips each, unless ordered without clips. Optional markings may be specified (black on yellow; white on black).

Notes: Covers can not be used with mounting plate options MP & MT.  
Covers can not be used with certain quick connect terminals.  
Covers can not be used with 0, 6, & 9 base/end styles on A2 or A3

Bulk Cover Clips: Series 1000 = CC1; Series 2000 & 3000 = CC2.

#### Standard Cover Markings

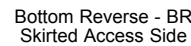
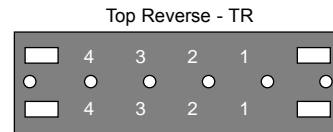
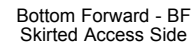
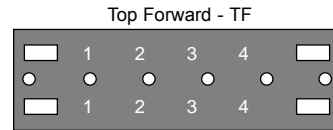

Cover Options  
BB & CB  
Skirted access  
on both sides.



Cover Options  
BO & CO  
Skirted access  
on one side only.

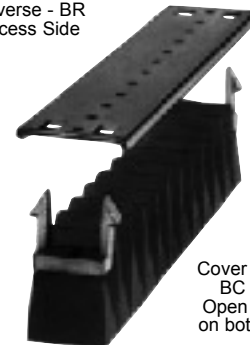

Cover Options  
BC & TC  
Open access  
on both sides.

Cover	Series	Poles	Markings	Options
nn	n	nn	nn	nn
BB - skirted access, both sides, black CB - skirted access, both sides, yellow BO - skirted access, one side, black CO - skirted access, one side, yellow BC - open access, both sides, black TC - open access, both sides, yellow	1 - 1000 2 - 2000 3 - 3000	02 to 36	BF - bottom forward TF - top forward BR - bottom reverse TR - top reverse	00 - without clips

## New Snap-On Covers for A38/B38 Series & CB2/CB3 Series



Poles  
n A n - n n A38 Series  
n B n - n n B38 Series



Poles  
n A n - n n CB2 Series  
n B n - n n CB3 Series

## Series TB100 Double Row Terminal Blocks

### SPECIFICATIONS

Rating: UL: 20A, 250V\*

CSA: 20A, 150V\*

Center Spacing: .375" or 3/8" (9.52 mm)

Wire Size: #14 - 22 AWG CU

Screw Size: #6-32 philslot screws

Torque Rating: 9 in-lb. max.

Distance Between Barriers: .30" (7.62 mm)

Mounting: #6 screws

Materials: Molded base: Black, UL rated 94VO thermoplastic

Terminal plating: Tin over brass; Screws: Zinc plated steel

Operating Temperature: 130°C (260°F) max., -40°C (-40°F) min.

Breakdown Voltage: 3600V rms

Approvals: UL E62622; CSA LR15364; IEC Compliance;

CE Certified

\* Max. rating shown; some options may be rated lower - consult factory.



TB100-08



TB100-045P

Poles	A	B	Poles	A	B	Poles	A	B
02	1.40	1.12	14	5.90	5.62	26	10.40	10.12
03	1.78	1.50	15	6.28	6.00	27	10.78	10.50
04	2.16	1.88	16	6.66	6.38	28	11.16	10.88
05	2.53	2.25	17	7.03	6.75	29	11.53	11.25
06	2.90	2.62	18	7.40	7.12	30	11.90	11.62
07	3.28	3.00	19	7.78	7.50	31	12.28	12.00
08	3.66	3.38	20	8.16	7.88	32	12.66	12.38
09	4.03	3.75	21	8.53	8.25	33	13.03	12.75
10	4.40	4.12	22	8.90	8.62	34	13.40	13.12
11	4.78	4.50	23	9.28	9.00	35	13.78	13.50
12	5.16	4.88	24	9.66	9.38	36	14.16	13.88
13	5.53	5.25	25	10.03	9.75			

\* Dimensions in inches. To convert to millimeters, multiply by 25.4.

TB100

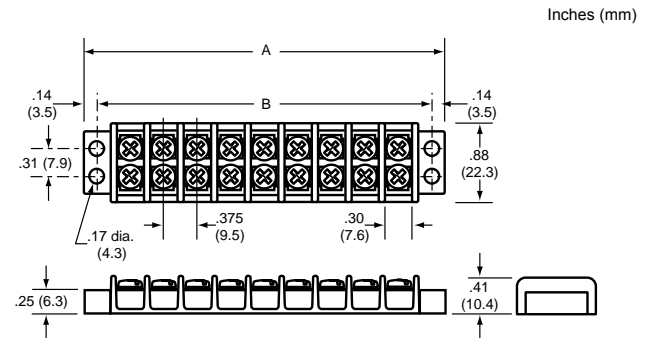

## Part Numbering System

Series

**TB100**

Poles

**nn**

02 to 36

Screw Options

**nn**

Blank - std. screws  
 00 - screws shipped bulk  
 B - brass philslot, nickel plated  
 BS - brass Sems philslot, nickel plated  
 SP - steel Sems philslot, zinc plated  
 ST - stainless steel, philslot

Marking

**nn**

L1 to L6 - std. marking  
 Marker strips (pg 33)  
 Covers (pg 32)

Hardware Options

**nnnn**

QC1 to QC20 - quick connects

Screw Options



B  
Brass Philslot  
Nickel Plated



BS  
Brass SEMS  
Philslot Nickel Plated



SP  
Steel SEMS  
Philslot Zinc Plated



ST  
Stainless Steel  
Philslot

Hardware Options

Quick Connects – Assembled Terminals .187" x .020". Max. current rating 13 Amps. For other orientations, contact factory.

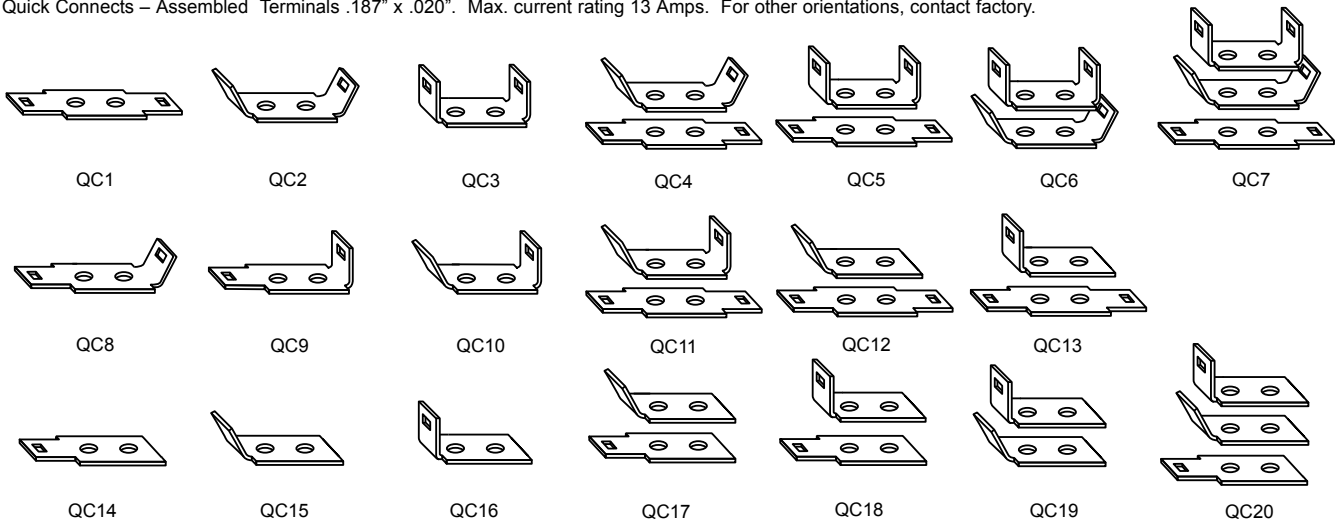

Quick Connects – Bulk Min. order per part no. – 100 pieces.

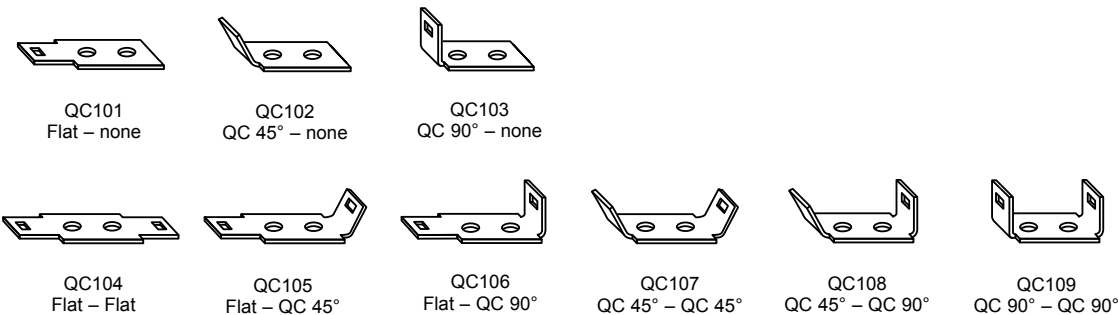

Jumpers – Bulk Min. order per part no. – 100 pieces. Contact factory for jumper assembly.

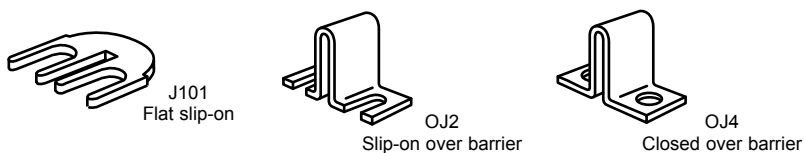



## Series TB200 & TB200HB Double Row Terminal Blocks

### SPECIFICATIONS

Rating: TB200 – 20A, 300V\*  
 TB200HB – 20A, 600\*.  
 Center Spacing: .437" or 7/16" (11.10 mm)  
 Wire Size: #12 - 22 AWG CU  
 Screw Size: #6-32 phillslot screws  
 Torque Rating: 9 in-lb. max.  
 Distance Between Barriers: .353" (8.97 mm)  
 Mounting: #6 screws  
 Materials: Molded base: Black, UL rated 94VO thermoplastic  
 Terminal plating: Tin over brass; Screws: Zinc plated steel  
 Operating Temperature: 130°C (260°F) max., -40°C (-40°F) min.  
 Breakdown Voltage: 4800V rms  
 Approvals: UL E62622; CSA LR15364; IEC Compliance;  
 CE Certified

\* Max. rating shown; some options may be rated lower - consult factory.

Poles	A	B	Poles	A	B	Poles	A	B
02	1.63	1.31	12	6.00	5.68	22	10.37	10.06
03	2.07	1.75	13	6.44	6.12	23	10.81	10.50
04	2.51	2.18	14	6.87	6.56	24	11.25	10.93
05	2.94	2.62	15	7.31	7.00	25	11.68	11.37
06	3.38	3.06	16	7.75	7.43	26	12.12	11.81
07	3.82	3.50	17	8.19	7.87	27	12.56	12.25
08	4.25	3.93	18	8.62	8.31	28	13.00	12.68
09	4.69	4.37	19	9.06	8.75	29	13.44	13.12
10	5.13	4.81	20	9.50	9.18	30	13.87	13.56
11	5.57	5.25	21	9.94	9.62			

\* Dimensions in inches. To convert to millimeters, multiply by 25.4.

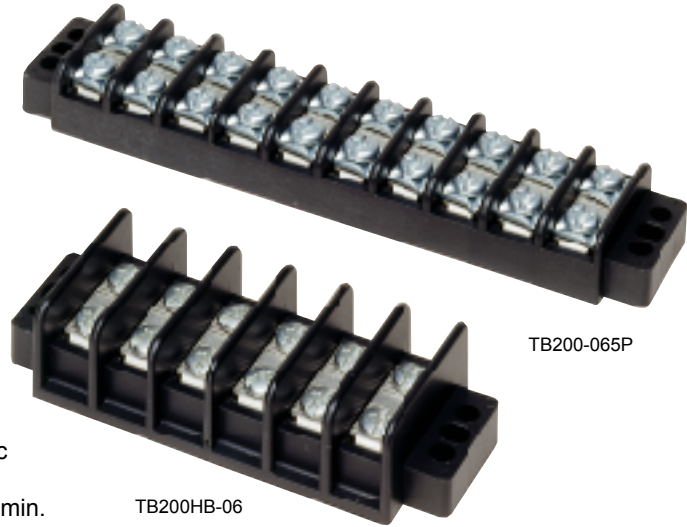

TB200

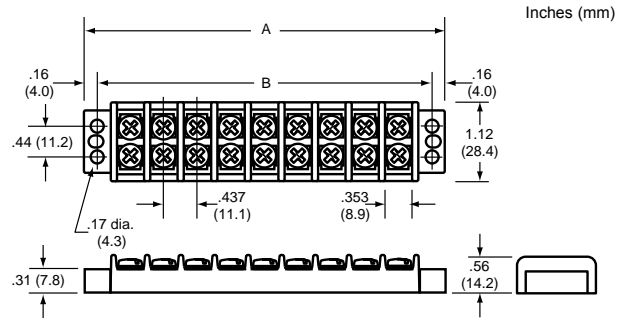

TB200HB

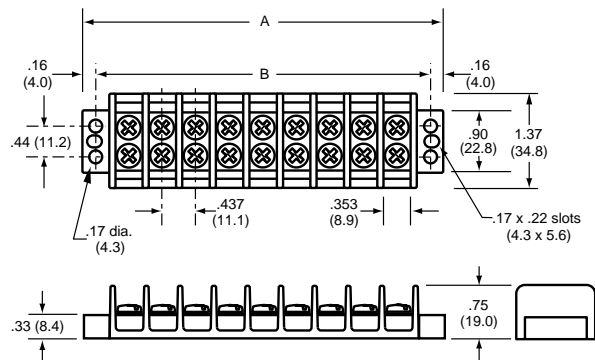

## Part Numbering System

Series

**TB200**nn-nn

200 - Standard  
 200HB - High barrier

Poles

02 to 30

Screw Options

nn

Blank - std. screws  
 00 - screws shipped bulk  
 B - brass phillslot, nickel plated  
 BS - brass Sems phillslot, zinc plated  
 SP - steel Sems phillslot, zinc plated  
 ST - stainless steel, phillslot

Marking

nn

L1 to L6 - std. marking  
 Marker strips (pg 33)  
 Covers (pg 32)

Hardware Options

nnnn

QC1 to QC20 - quick connects

# MAGNUM®

## Screw Options



**B**  
Brass Phillips  
Nickel Plated

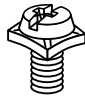

**BS**  
Brass SEMS  
Phillips Nickel Plated



**SP**  
Steel SEMS  
Phillips Zinc Plated



**ST**  
Stainless Steel  
Phillips

## Hardware Options

Quick Connects – Assembled Terminals .250" x .031". Max. current rating 20 Amps. For other orientations, contact factory.

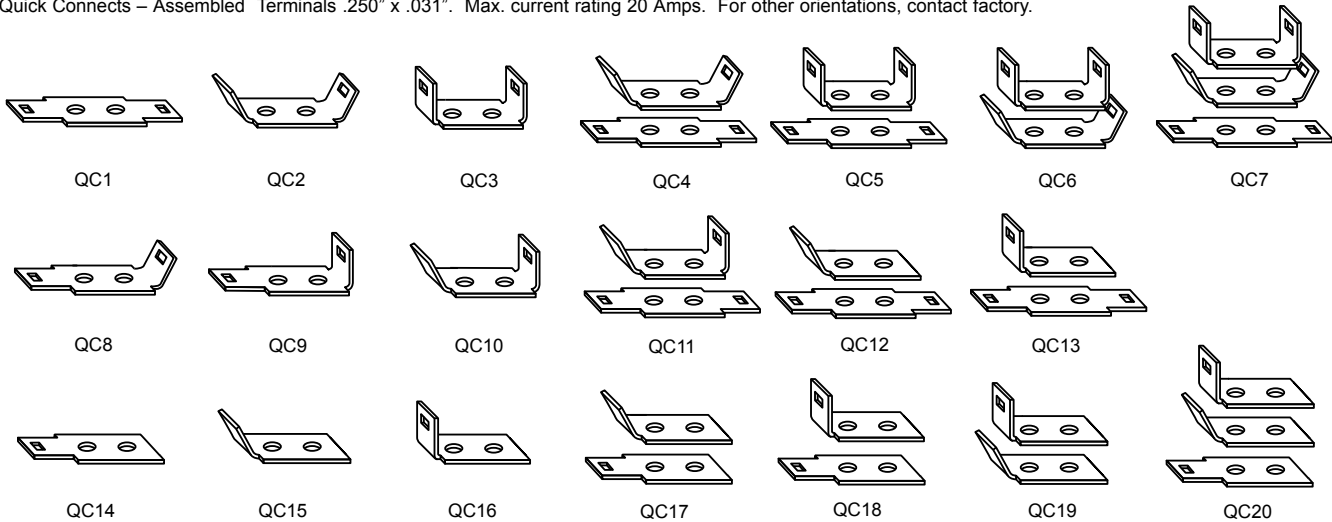

Quick Connects – Bulk Min. order per part no. – 100 pieces.

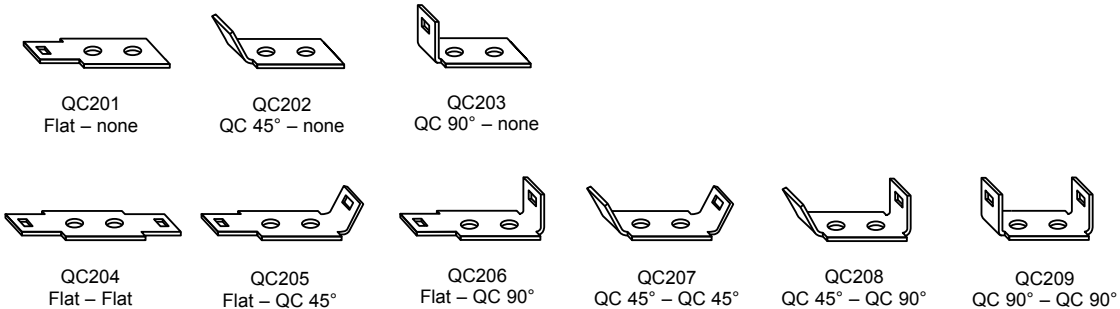

Jumpers – Bulk Min. order per part no. – 100 pieces. Contact factory for jumper assembly.

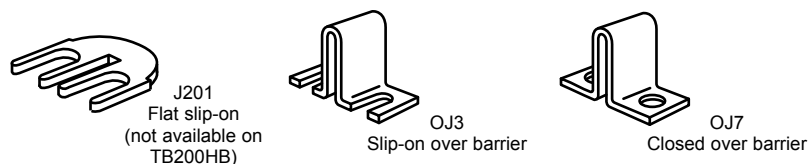

## Series TB300 & TB345 Double Row Terminal Blocks

### SPECIFICATIONS

Rating: TB300 – 30A, 600V\*

TB345 – 45A, 600V\*

Center Spacing: .562" or 9/16" (14.28 mm)

Wire Size: #10 - 22 AWG CU

Screw Size: TB300 – #8-32 philslot screws  
TB345 – #10-32 philslot screws

Torque Rating: #8 screws - 16 in-lb.;

#10 screws - 20 in-lb.

Distance Between Barriers: .41" (10.5 mm)

Mounting: TB300 – #8 screws; TB345 – #10 screws

Material: Molded base: Black, UL rated 94VO thermoplastic

Terminal plating: Tin over brass; Screws: Zinc plated steel

Operating Temperature: 130°C (260°F) max., -40°C (-40°F) min.

Breakdown Voltage: 7500V rms

Approvals: UL E62622; CSA LR15364; IEC Compliance;  
CE Certified

\* Max. rating shown; some options may be rated lower - consult factory.



Poles	A	B	Poles	A	B	Poles	A	B
02	2.13	1.69	10	6.62	6.19	18	11.12	10.68
03	2.69	2.25	11	7.18	6.75	19	11.68	11.25
04	3.25	2.81	12	7.75	7.31	20	12.24	11.81
05	3.81	3.37	13	8.31	7.87	21	12.80	12.37
06	4.37	3.94	14	8.87	8.44	22	13.37	12.93
07	4.94	4.50	15	9.43	9.00	23	13.93	13.50
08	5.50	5.06	16	9.99	9.56	24	14.49	14.06
09	6.06	5.62	17	10.56	10.12			

\* Dimensions in inches. To convert to millimeters, multiply by 25.4.

TB300 & TB345

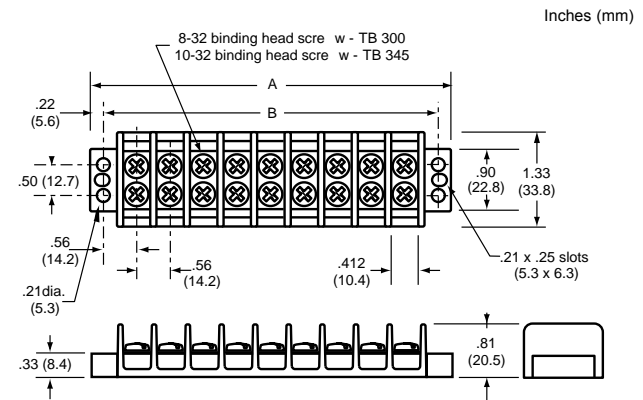

## Part Numbering System

Series	Poles	Screw Options	Marking	Hardware Options
<b>TB300</b>	<b>nn</b>	<b>nn</b>	<b>nn</b>	<b>nnnnn</b>
300 - 8/32 screw 345 - 10/32 screw	02 to 24	Blank - std. screws 00 - screws shipped bulk B - brass philslot, nickel plated BS - brass Sems philslot, zinc plated (TB300 only) SP - steel Sems philslot, zinc plated ST - stainless steel, philslot	L1 to L6 - std. marking Marker strips (pg 33) Covers (pg 32)	QC1 to QC20 - quick connects (TB300 only)

## Screw Options



**B**  
Brass Phillips  
Nickel Plated



**BS**  
Brass SEMS  
Phillips Nickel Plated



**SP**  
Steel SEMS  
Phillips Zinc Plated



**ST**  
Stainless Steel  
Phillips

## Hardware Options

Quick Connects – Assembled TB300 only. Terminals .250" x .031". Max. current rating 20 Amps. For other orientations, contact factory.

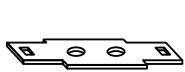

QC1



QC2

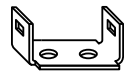

QC3

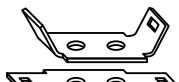

QC4



QC5

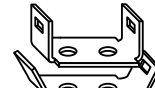

QC6

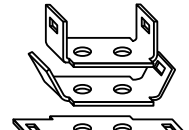

QC7



QC8

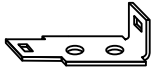

QC9



QC10

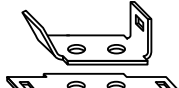

QC11

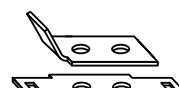

QC12

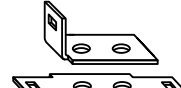

QC13



QC14



QC15

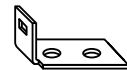

QC16

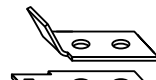

QC17

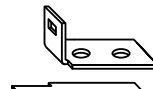

QC18

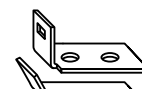

QC19

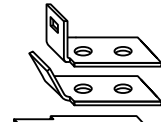

QC20

Quick Connects – Bulk \*TB300 only. Min. order per part no. – 100 pieces.



QC201  
Flat – none



QC202  
QC 45° – none

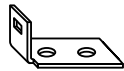

QC203  
QC 90° – none



QC204  
Flat – Flat



QC205  
Flat – QC 45°



QC206  
Flat – QC 90°



QC207  
QC 45° – QC 45°



QC208  
QC 45° – QC 90°

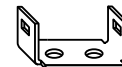

QC209  
QC 90° – QC 90°

Jumpers – Bulk Min. order per part no. – 100 pieces. Contact factory for jumper assembly.



J301  
Flat slip-on  
(TB300 only)

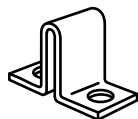

OJ6  
Closed over barrier

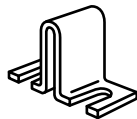

OJ11  
Slip-on over barrier

## Series TB400 Double Row Terminal Blocks

### SPECIFICATIONS

Rating: 75A, 600V\*  
 \* 75A max. with pressure terminal connector and #4 AWG;  
 30A max. with #10 AWG;  
 Center Spacing: .687" or 11/16" (17.45 mm)  
 Wire Size: #10-14 AWG CU  
 Screw Size: #10-32 philslot screws  
 Torque Rating: 20 in-lb.  
 Distance Between Barriers: .56" (14.3 mm)  
 Mounting: #10 screws  
 Material: Molded base: Black, UL rated 94VO thermoplastic  
 Terminal plating: Tin over brass; Screws: Zinc plated steel  
 Operating Temperature: 130°C (260°F) max., -40°C (-40°F) min.  
 Breakdown Voltage: 7500V rms  
 Approvals: UL E62622; CSA LR15364; IEC Compliance;  
 CE Certified



TB400-05

Poles	A	B	Poles	A	B	Poles	A	B
02	2.51	2.06	06	5.26	4.81	10	8.01	7.56
03	3.20	2.75	07	5.95	5.50	11	8.70	8.25
04	3.89	3.44	08	6.64	6.19	12	9.39	8.94
05	4.58	4.13	09	7.33	6.88			

\* Dimensions in inches. To convert to millimeters, multiply by 25.4.

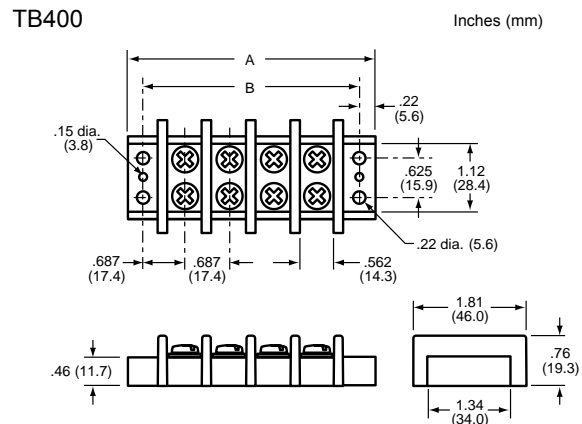

### Screw Options



B  
Brass Philslot  
Nickel Plated



ST  
Stainless Steel  
Philslot

### Part Numbering System

Series	Poles	Screw Options	Marking	Hardware Options
TB400	- nn 02 to 12	nn Blank - std. screws 00 - screws shipped bulk B - brass philslot, nickel plated ST - stainless steel, philslot	Not available	Not available

# MAGNUM®

## All Series Marking Options & Accessories Double Row Terminal Blocks

### Marking Options

#### Standard Marking

Standard markings are applied directly to the side(s) of a block. Standard color is white. Standard height is .125".

Note: Blocks marked on both sides require a different code for each side. Example Style L1 on one side of the block requires Style L2 on the other side to ensure common terminal marking. To order, add appropriate suffix (L1, L2, L3, L4, L5 and/or L6) to block part number in the proper sequence.

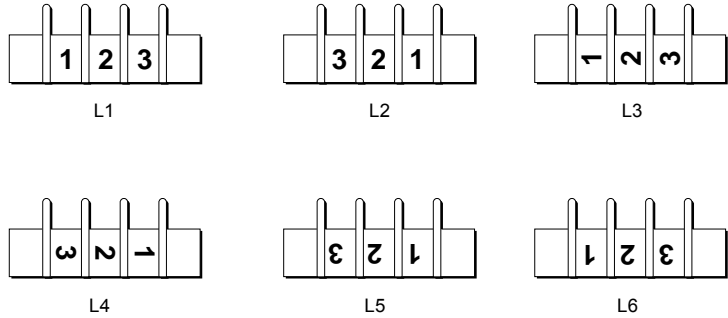

#### Special Marking

Special markings are available at an additional charge for preparation. Production charges for setup, handling and marking are the same as for standard marking. Drawing(s) must be submitted to ensure accuracy of part required. Consult factory for price and delivery.

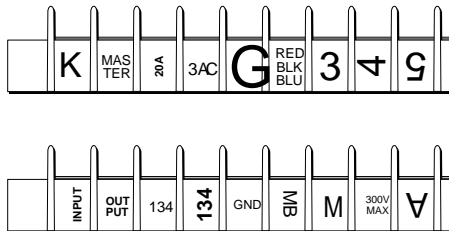

Note: Marking is not available on TB400 Series

### Covers

Covers prevent personnel, screws and foreign items from contacting live terminals. Available in white or clear plastic. Two cover clips supplied with each cover. Cover width is 1.31 inches.

All covers must be ordered separately. Consult factory for special legends.

Example: 10 position cover, white, TB100 Series, no legends . . . Part No. is X12010.

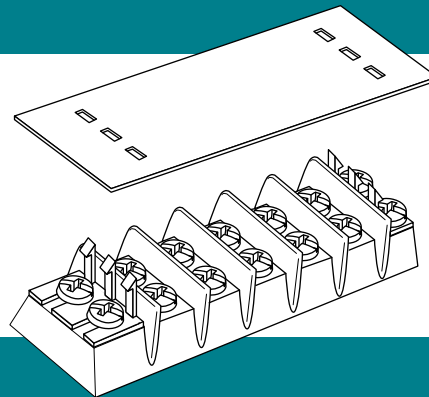

### Part Numbering System

Series	Cover Strip	Poles	Cover Clips – Bulk
	<b>nnn</b>	<b>nn</b>	Part Number
	120 - TB100/white	02 to 36 (TB100)	DD1 – TB100 Series
	119 - TB100/clear	02 to 30 (TB200/TB200HB)	DD2 – TB200 Series
	220 - TB200 & TB200HB* - white	02 to 24 (TB300/TB345)	DD2HB – TB200HB Series
	219 - TB200 & TB200HB* - clear		DD3 – TB300 Series
	320 - TB300 & TB345 - white		
	319 - TB300 & TB345 - clear		

Note: Covers are not available on TB400 Series.  
\* For use on TB200HB, specify HB after Part No. i.e., X21902HB



## Top & Bottom Marking Strips Double Row Terminal Blocks

### Top Marker Strips

Top mounting marker strips are available in white (opaque) plastic. Two cover clips are supplied with each marker strip.

All top marker strips must be ordered separately. Consult factory for special legends.

Example: 12 position cover, TB200, .032" x .312", with no legends . . . Part No. is X20312.

Example: 12 position cover, TB200HB, .060" x .500", with no legends . . . Part No. is X23312HB.

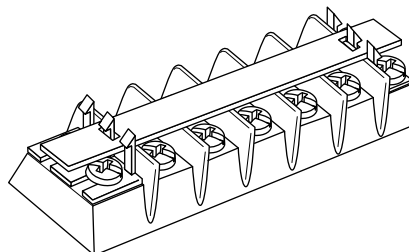

## Part Numbering System

Series



Top Marker Strip



- 133 - TB100 (.060 thk x .500w)
- 103 - TB100 (.032 thk x .312w)
- 233 - TB200 & TB200HB\* (.060 thk x .500w)
- 203 - TB200 & TB200HB\* (.032 thk x .312w)
- 333 - TB300 & TB345 (.060 thk x .500w)
- 303 - TB300 & TB345 (.032 thk x .380w)

Poles



- 02 to 36 (TB100)
- 02 to 30 (TB200/TB200HB)
- 02 to 24 (TB300/TB345)

Note: Marking Strips are not available on TB400 Series.

\* For use on TB200HB, specify HB after Part No. i.e., X23302HB

### Bottom Marker Strips

Bottom mounting marker strips are made of black PVC, .030" thick. Space is available to handle most marking situations. All marker strips must be ordered separately.

To order, specify part number, required legends and (BF) bottom forward, (BR) bottom reverse, (TF) top forward, or (TR) top reverse. Consult factory for specials.

Example: 13 position strip, TB100 with no legends, space for marking one side . . . Part No. is X10513.

Position for legends (one side, two sides) can be specified standard. Standard legend height is .125". Standard legends are 0-99 and A-Z. Special legends are available on special order. Drawing(s) must be submitted to ensure accuracy of part required.

Space for marking one side

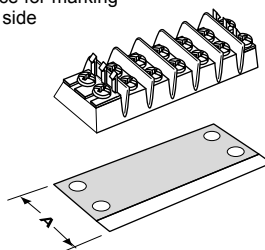

Space for marking two sides

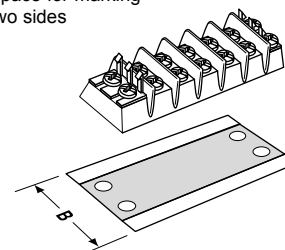

	TB100	TB200	TB200HB	TB300	TB345	TB400
Dim. A	1.13"	1.37"	1.62"	1.58"	1.58"	N/A
Dim. B	1.38"	1.62"	1.81"	1.81"	1.81"	N/A

## Part Numbering System

Series



Bottom Marker Strip



- 105 - TB100 – marking one side
- 101 - TB100 – marking both sides
- 205 - TB200 – marking one side
- 201 - TB200 – marking both sides
- 295 - TB200HB – marking one side
- 291 - TB200HB – marking both sides
- 305 - TB300 & TB345 – marking one side
- 301 - TB300 & TB345 – marking both sides

Poles



- 02 to 36 (TB100)
- 02 to 30 (TB200/TB200HB)
- 02 to 24 (TB300/TB345)

Orientation



- BF – bottom forward
- BR – bottom reverse
- TF – top forward
- TR – top reverse

Note: Marking Strips are not available on TB400 Series.

# MAGNUM®

## EM2505 Series Euro-Mag Terminal Blocks Stackable, 5.08 Centers

### SPECIFICATIONS

Rating: 15A, 300V  
 Center Spacing: .200" (5.08 mm)  
 Consult factory for .300" (7.62 mm) and .400" (10.16 mm)  
 Wire Size: #12-22 AWG  
 Housing Material: Green Polyamide Type 6/6, 94VO  
 Contact Material: Brass Tin Plated  
 Screw Size: M 3x5 Zinc Plated Steel  
 Operating Temperature: 105°C (221°F) max., -40°C (-40°F) min.  
 Torque Rating: 4.5 in-lb. max.  
 Recommended PCB Hole Diameters: .055" (1.40)  
 Construction: Modular design features dove-tails for interlocking to achieve longer lengths.  
 Approvals: UL E62622; CSA LR701941; CE Certified

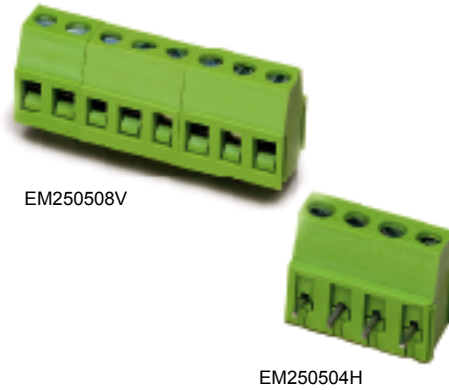
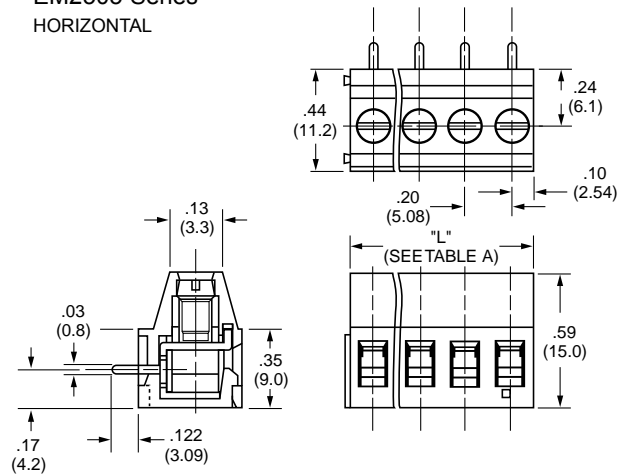

TABLE A

Position	L (mm)	Position	L (mm)
02*	10.16	14	71.12
03*	15.24	15	76.20
04	20.32	16	81.28
05	25.40	17	86.36
06	30.48	18	91.44
07	35.56	19	96.52
08*	40.64	20	101.60
09	45.72	21	106.68
10	50.80	22	111.76
11	55.88	23	116.84
12	60.96	24	121.92
13	66.04		

\* Mold To Length  
 To convert to inches, divide by 25.4

EM2505 Series  
HORIZONTAL



VERTICAL

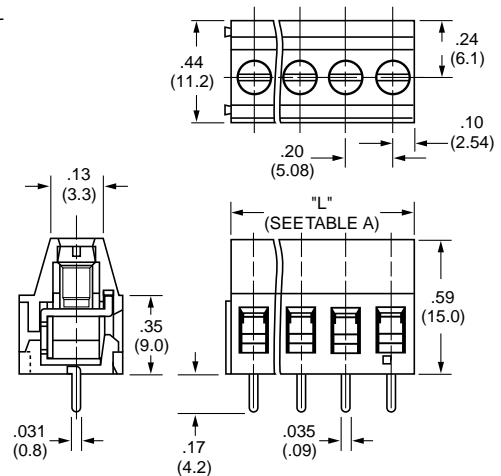

### Part Numbering System

Series	# of Positions	Orientation
EM2505	nn	n
	02 to 24	H - horizontal V - vertical

**EM2585 Series**  
**Euro-Mag Terminal Blocks**  
 Stackable, 5.00 Centers

**SPECIFICATIONS**

Rating: 15A, 300V  
 Center Spacing: .197" (5.00 mm)  
 Consult factory for .393" (10.00 mm)  
 Wire Size: #12-22 AWG  
 Housing Material: Green Polyamide Type 6/6, 94VO  
 Contact Material: Brass Tin Plated  
 Screw Size: M 3x5 Zinc Plated Steel  
 Operating Temperature: 105°C (221°F) max., -40°C (-40°F) min.  
 Torque Rating: 4.5 in-lb. max.  
 Recommended PCB Hole Diameters: .055" (1.40)  
 Construction: Modular design features dove-tails for interlocking to achieve longer lengths.  
 Approvals: UL E62622; CSA LR701941; CE Certified

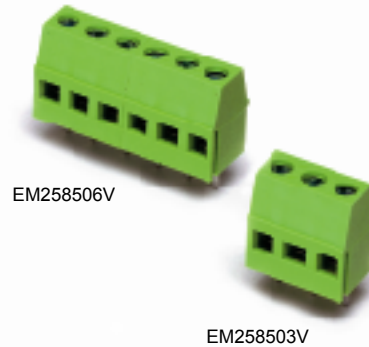

**EM2585 Series**  
 HORIZONTAL

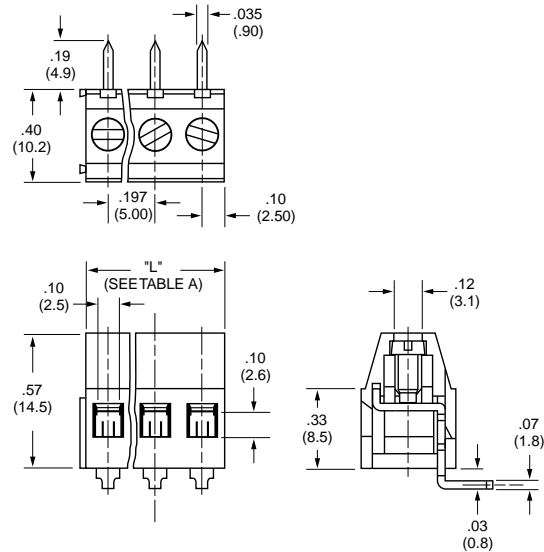

**VERTICAL**

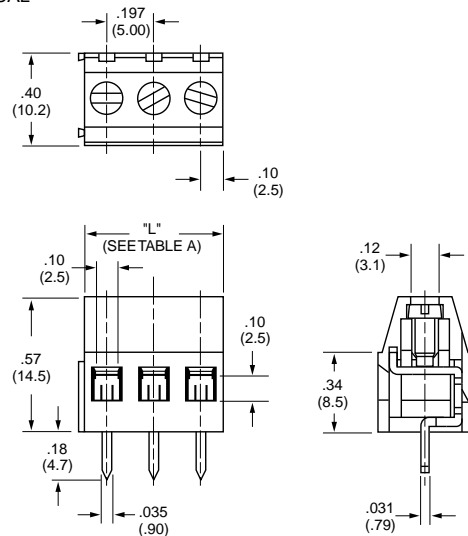

**TABLE A**

Position	L (mm)	Position	L (mm)
02*	10.00	14	70.00
03*	15.00	15	75.00
04	20.00	16	80.00
05	25.00	17	85.00
06	30.00	18	90.00
07	35.00	19	95.00
08	40.00	20	100.00
09	45.00	21	105.00
10	50.00	22	110.00
11	55.00	23	115.00
12	60.00	24	120.00
13	65.00		

\* Mold To Length  
 To convert to inches, divide by 25.4

**Part Numbering System**

Series	# of Positions	Orientation
EM2585	nn	n
	02 to 24	H - horizontal V - vertical

# MAGNUM®

## EM3503 Series Euro-Mag Terminal Blocks 3.81 Centers

### SPECIFICATIONS

Rating: 10A, 125V  
 Center Spacing: .150" (3.81 mm)  
 Wire Size: #16 AWG  
 Housing Material: Green Polyamide Type 6/6, 94VO  
 Contact Material: Brass Tin Plated  
 Screw Size: M 2x3 Zinc Plated Steel  
 Operating Temperature: 105°C (221°F) max., -40°C (-40°F) min.  
 Torque Rating: 4.5 in-lb.  
 Recommended PCB Hole Diameters: .055" (1.40)  
 Construction: Mold to Length  
 Approvals: UL & CSA Approvals Pending; CE Certified

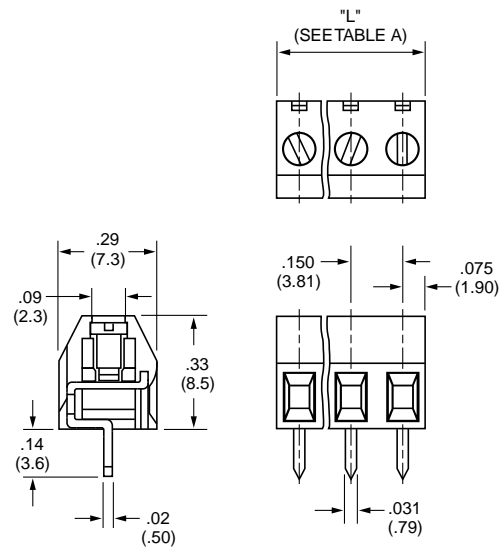

TABLE A

Position	L (mm)
02	7.61
03	11.42

To convert to inches, divide by 25.4

### EM3503 Series



## Part Numbering System

Series # of Positions

EM3503 nn

02  
03

**EM2665 Series**  
**Euro-Mag Terminal Blocks**  
**5.00 Centers**

**SPECIFICATIONS**

Rating: 15A, 300V  
 Center Spacing: .197" (5.00 mm)  
 Consult factory for .393" (10.00 mm)  
 Wire Size: #14-22 AWG  
 Housing Material: Green Polyamide Type 6/6, 94VO  
 Contact Material: Brass Tin Plated  
 Screw Size: M 3x5 Zinc Plated Steel  
 Operating Temperature: 105°C (221°F) max., -40°C (-40°F) min.  
 Torque Rating: 4.5 in-lb.  
 Recommended PCB Hole Diameters: .055" (1.40)  
 Construction: Mold to Length  
 Approvals: UL E62622; CSA LR 701941; CE Certified

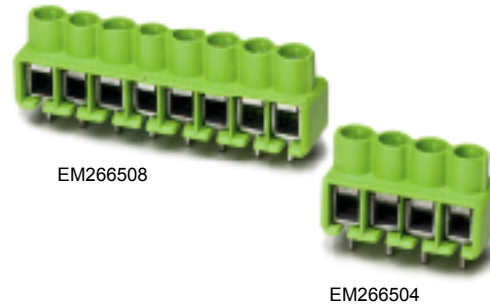
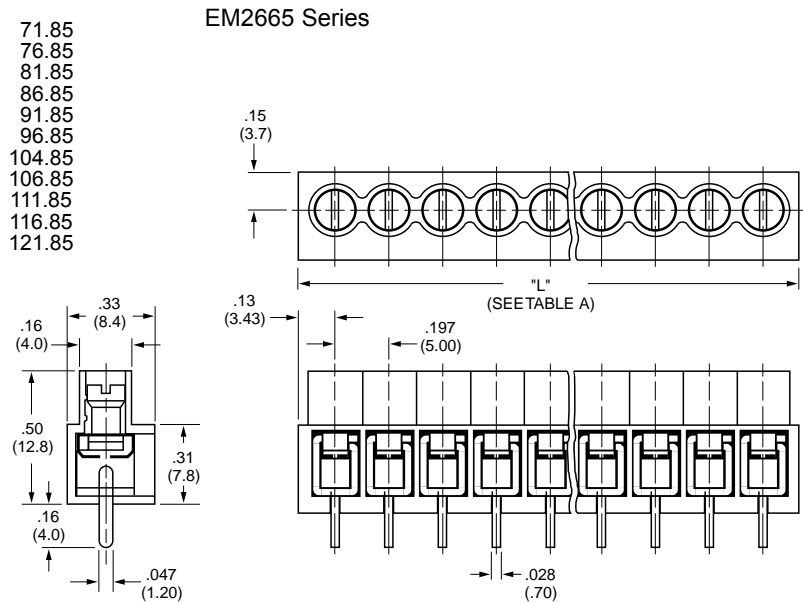

**TABLE A**

Position	L (mm)	Position	L (mm)
02	11.85	14	71.85
03	16.85	15	76.85
04	21.85	16	81.85
05	26.85	17	86.85
06	31.85	18	91.85
07	36.85	19	96.85
08	41.85	20	104.85
09	46.85	21	106.85
10	51.85	22	111.85
11	56.85	23	116.85
12	61.85	24	121.85
13	66.85		

To convert to inches, divide by 25.4

**EM2665 Series**



**Part Numbering System**

Series # of Positions

**EM2665** n n

02 to 24

# MAGNUM®

## EM3665 Series Euro-Mag Terminal Blocks Stackable, 5.00 Centers

### SPECIFICATIONS

Rating: 10A, 300V  
 Center Spacing: .197" (5.00)  
 Wire Size: #16-22 AWG  
 Housing Material: Green Polyamide Type 6/6, 94VO  
 Contact Material: Tin Plated Brass  
 Screw Size: M 2.5x5 Zinc Plated Steel  
 Operating Temperature: 105°C (221°F) max., -40°C (-40°F) min.  
 Torque Rating: 3.0 in-lb.  
 Recommended PCB Hole Diameters: .055" (1.40)  
 Construction: Modular design features dove-tails for interlocking to achieve longer lengths.  
 Agency Approvals: UL & CSA Approvals Pending;  
 CE Certified



EM366502

EM3665 Series

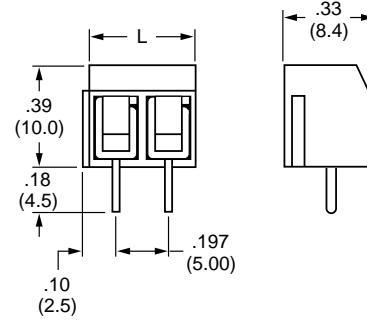

TABLE A

Poles	L (mm)	Poles	L (mm)
2	10.00	14	70.00
3	15.00	15	75.00
4	20.00	16	80.00
5	25.00	17	85.00
6	30.00	18	90.00
7	35.00	19	95.00
8	40.00	20	100.00
9	45.00	21	105.00
10	50.00	22	110.00
11	55.00	23	115.00
12	60.00	24	120.00
13	65.00		

To convert to inches, divide by 25.4

## Part Numbering System

Series # of Poles

EM3665 nn

02 to 24



**EM3675 Series**  
**Euro-Mag Terminal Blocks**  
**5.00 Centers**

**SPECIFICATIONS**

Rating: 10A, 300V  
 Center Spacing: .197" (5.00)  
 Wire Size: #14-26 AWG  
 Housing Material: Polyamide 66 (UL94V-0) Green Polyamide Type 6/6 94VO  
 Contact Material: Tin Plated Brass  
 Screw Size: M 2x6, Nickel Plated Steel  
 Operating Temperature: 105°C (221°F) max., -40°C (-40°F) min.  
 Torque Rating: 4.0 in-lb.  
 Recommended PCB Hole Diameters: .055" (1.40)  
 Construction: Mold to Length  
 Agency Approvals: UL362622; CSA Pending; CE Certified

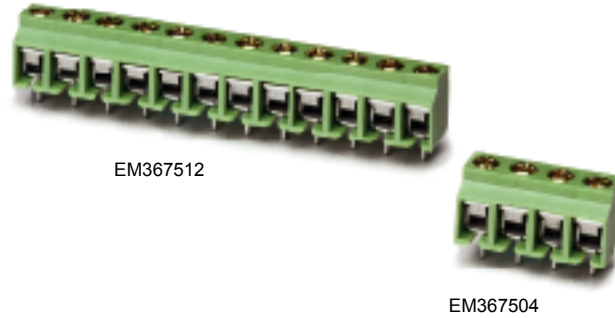
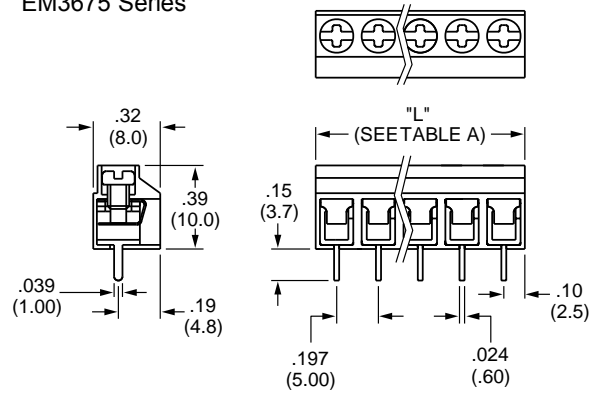

**TABLE A**

Poles	L (mm)	Poles	L (mm)
2	10.00	15	75.00
3	15.00	16	80.00
4	20.00	17	85.00
5	25.00	18	90.00
6	30.00	19	95.00
7	35.00	20	100.00
8	40.00	21	105.00
9	45.00	22	110.00
10	50.00	23	115.00
11	55.00	24	120.00
12	60.00	25	125.00
13	65.00	26	130.00
14	70.00	27	135.00

To convert to inches, divide by 25.4

**EM3675 Series**



**Part Numbering System**

Series # of Poles  
**EM3675** **nn**  
 02 to 27

# MAGNUM®

## EM2515 Series Euro-Mag Terminal Blocks 45° Angle, Stackable, 5.08 Centers

### SPECIFICATIONS

Rating: 15A, 300V  
 Center Spacing: .200" (5.08 mm)  
 Consult factory for .400" (10.16mm)  
 Wire Size: #12-22 AWG  
 Housing Material: Green Polyamide Type 6/6, 94VO  
 Contact Material: Brass Tin Plated  
 Screw Size: M 3x5 Zinc Plated Steel  
 Operating Temperature: 105°C (221°F) max., -40°C (-40°F) min.  
 Torque Rating: 4.5 in-lb.  
 Recommended PCB Hole Diameters: .055" (1.40)  
 Construction: Modular design features dove-tails for interlocking to achieve longer lengths.  
 Approvals: UL E62622; CSA LR701941; CE Certified

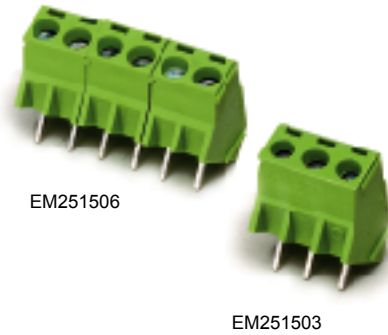

EM2515 Series

TABLE A

Position	L (mm)	Position	L (mm)
02*	10.16	14	71.12
03*	15.24	15	76.20
04	20.32	16	81.28
05	25.40	17	86.36
06	30.48	18	91.44
07	35.56	19	96.52
08	40.64	20	101.60
09	45.72	21	106.68
10	50.80	22	111.76
11	55.88	23	116.84
12	60.96	24	121.92
13	66.04		

\* Mold To Length  
 To convert to inches, divide by 25.4

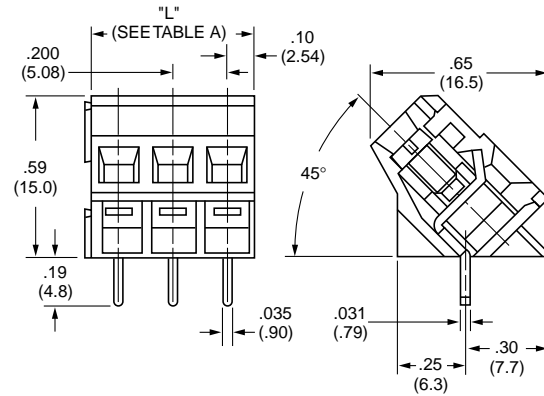

## Part Numbering System

Series # of Positions

EM2515 nn

02 to 24

**EM2795 Series**  
**Euro-Mag Terminal Blocks**  
**Screwless, Stackable, 5.08 Centers**

**SPECIFICATIONS**

Rating: 10A, 300V  
 Center Spacing: .200" (5.08)  
 Wire Size: #14-24 AWG  
 Housing Material: Green Polyamide Type 6/6, 94VO  
 Contact Material: Tin Plated Brass  
 Operating Temperature: 105°C (221°F) max., -40°C (-40°F) min.  
 Recommended PCB Hole Diameters: .051" (1.30)  
 Construction: Stackable to achieve longer lengths  
 Agency Approvals: UL E62622; CSA 701941; CE Certified

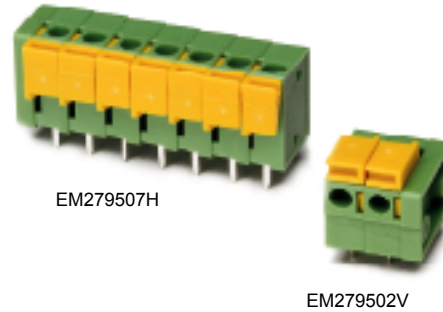

**TABLE A**

Poles	L (mm)	Poles	L (mm)
1	7.62	13	68.58
2	12.70	14	73.66
3	17.78	15	78.74
4	22.86	16	83.82
5	27.94	17	88.90
6	33.02	18	93.98
7	38.10	19	99.06
8	43.18	20	104.14
9	48.26	21	109.22
10	53.34	22	114.30
11	58.42	23	119.38
12	63.50	24	124.46

To convert to inches, divide by 25.4

**EM2795 Series**

**VERTICAL**

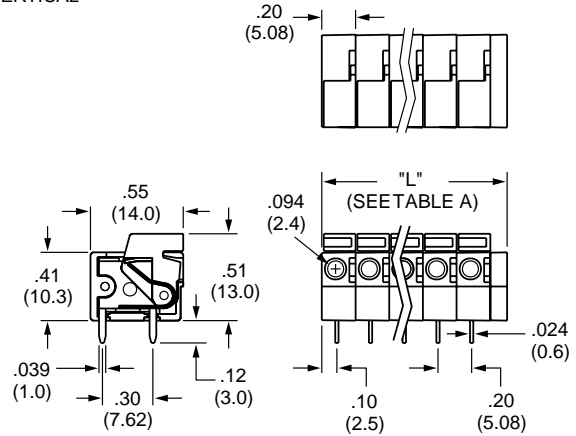

**HORIZONTAL**

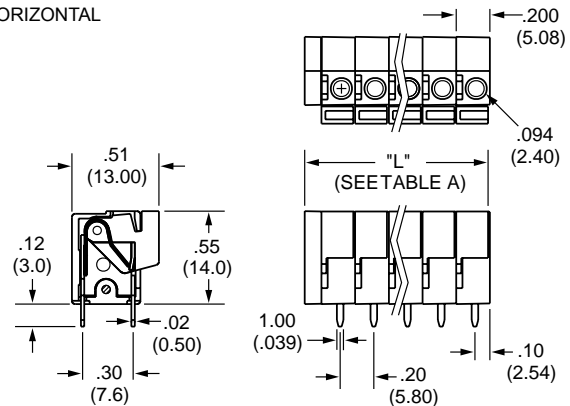

**Part Numbering System**

Series: **EM2795**      # of Positions: **nn**      Orientation: **n**

01 to 24      H - horizontal  
 V - vertical

# MAGNUM®

## EM2555 Series Euro-Mag Terminal Blocks 45° Angle, Stackable, 5.00 Centers

### SPECIFICATIONS

Rating: 15A, 300V  
 Center Spacing: .197" (5.00 mm)  
 Consult factory for .393" (10.00 mm)  
 Wire Size: #12-22 AWG  
 Housing Material: Green Polyamide Type 6/6, 94VO  
 Contact Material: Brass Tin Plated  
 Screw Size: M 3x5 Zinc Plated Steel  
 Operating Temperature: 105°C (221°F) max., -40°C (-40°F) min.  
 Torque Rating: 4.5 in-lb.  
 Recommended PCB Hole Diameters: .055" (1.40)  
 Construction: Modular design features dove-tails for interlocking to achieve longer lengths.  
 Approvals: UL E62622; CE Certified

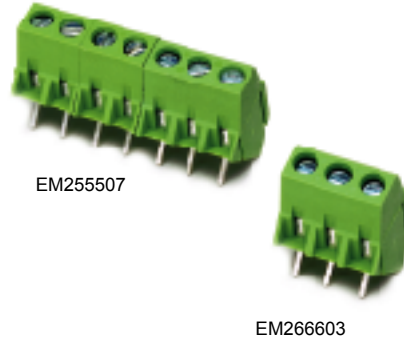
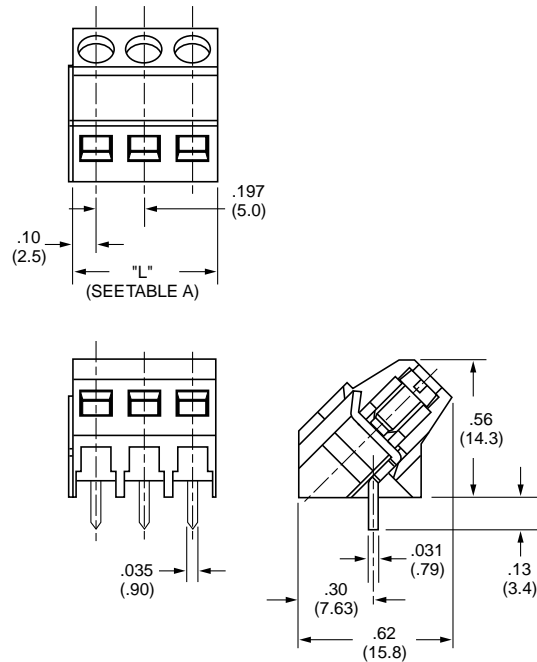

TABLE A

Position	L (mm)	Position	L (mm)
02*	10.00	14	70.00
03*	15.00	15	75.00
04	20.00	16	80.00
05	25.00	17	85.00
06	30.00	18	90.00
07	35.00	19	95.00
08	40.00	20	100.00
09	45.00	21	105.00
10	50.00	22	110.00
11	55.00	23	115.00
12	60.00	24	120.00
13	65.00		

\* Mold to Length  
 To convert to inches, divide by 25.4

EM2555 Series



## Part Numbering System

Series # of Positions

EM2555 nn

02 to 24

**EM2545 Series**  
**Euro-Mag Terminal Blocks**  
**Two-Tier, Stackable, 5.08 Centers**

**SPECIFICATIONS**

Rating: 15A, 300V  
 Center Spacing: .200" (5.08 mm)  
 Wire Size: #12-22 AWG  
 Housing Material: Green Polyamide Type 6/6, 94VO  
 Contact Material: Brass Tin Plated  
 Screw Size: M 3x5 Zinc Plated Steel  
 Operating Temperature: 105°C (221°F) max., -40°C (-40°F) min.  
 Torque Rating: 4.5 in-lb.  
 Recommended PCB Hole Diameters: .055" (1.40)  
 Construction: Modular design features dove-tails for interlocking to achieve longer lengths.  
 Approvals: UL E62622; CSA LR701941; CE Certified

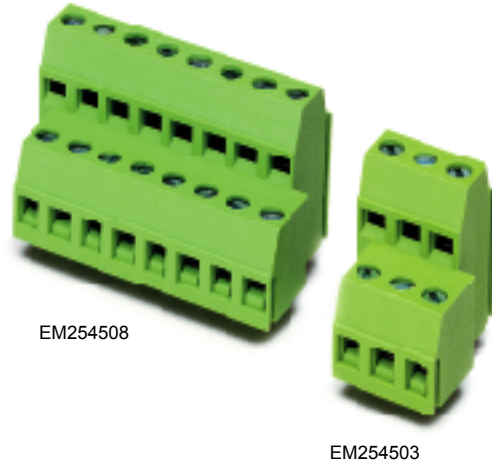
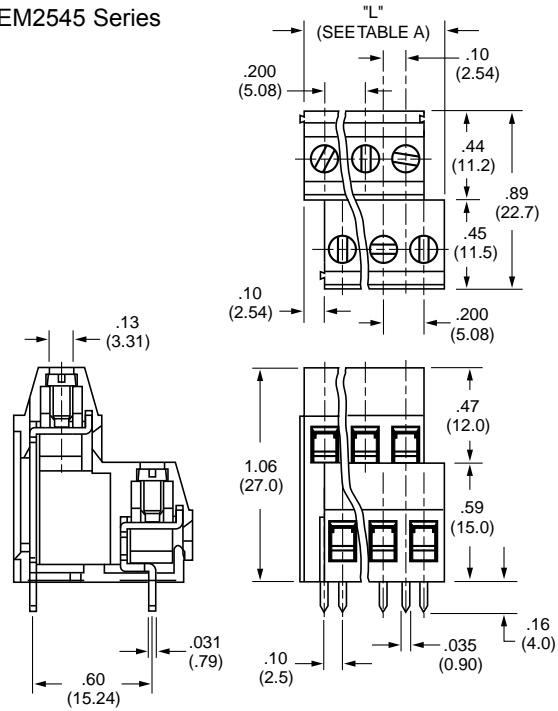

**TABLE A**

Position	L (mm)	Position	L (mm)
02*	10.16	14	71.12
03*	15.24	15	76.20
04	20.32	16	81.28
05	25.40	17	86.36
06	30.48	18	91.44
07	35.56	19	96.52
08*	40.64	20	101.60
09	45.72	21	106.68
10	50.80	22	111.76
11	55.88	23	116.84
12	60.96	24	121.92
13	66.04		

\* Mold To Length  
 To convert to inches, divide by 25.4

**EM2545 Series**



\* Also available with 10.16 mm front-to-rear spacing, consult factory

**Part Numbering System**

Series # of Positions

**EM2545** n n

02 to 24

# MAGNUM®

## EM2445 Series Euro-Mag Terminal Blocks Two Tier, Stackable, 5.00 Centers

### SPECIFICATIONS

Rating: 12A, 300V  
 Center Spacing: .197" (5.00)  
 Wire Size: #14-24 AWG  
 Housing Material: Green Polyamide Type 6/6, 94VO  
 Contact Material: Tin Plated Brass  
 Screw Size: M 2x6 Nickel Plated Steel  
 Operating Temperature: 105°C (221°F) max., -40°C (-40°F) min.  
 Torque Rating: 5.0 in-lb.  
 Recommended PCB Hole Diameters: .055" (1.40)  
 Construction: Modular design features dove tails for interlocking to achieve longer lengths.  
 Agency Approvals: UL E62622; CSA Pending; CE Certified

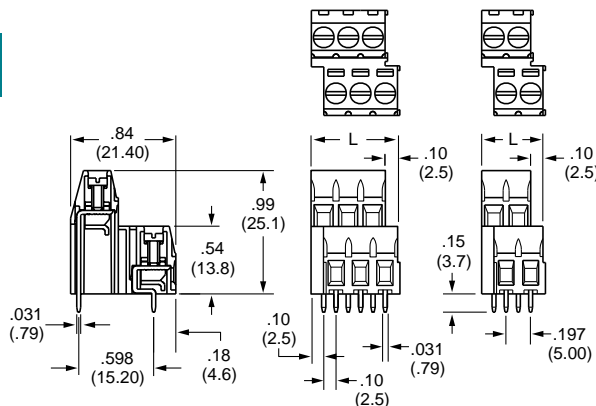

TABLE A

Poles	L (mm)	Poles	L (mm)
2	12.50	13	67.50
3	17.50	14	72.50
4	22.50	15	77.50
5	27.50	16	82.50
6	32.50	17	87.50
7	37.50	18	92.50
8	42.50	19	97.50
9	47.50	20	102.50
10	52.50	21	107.50
11	57.50	22	112.50
12	62.50	23	117.50
		24	122.50

To convert to inches, divide by 25.4

EM2445 Series



## Part Numbering System

Series # of Poles  
**EM2445** **nn**  
 02 to 24



**EM2565 Series**  
**Euro-Mag Terminal Blocks**  
 Depluggable Block (Mates with EM2575 Header), 5.08 Centers

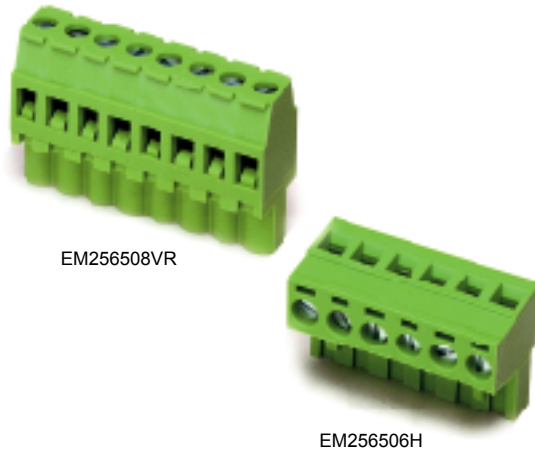

**SPECIFICATIONS**

Rating: 15A, 300V  
 Center Spacing: .200" (5.08 mm)  
 Consult factory for .400" (10.16 mm)  
 Wire Size: #12-22 AWG  
 Housing Material: Green Polyamide Type 6/6, 94VO  
 Contact Material: Brass Tin Plated  
 Screw Size: M 3x5 Zinc Plated Steel  
 Operating Temperature: 105°C (221°F) max., -40°C (-40°F) min.  
 Torque Rating: 4.5 in-lb.  
 Construction: Mold to Length  
 Approvals: UL E62622; CSA LR701941; CE Certified

**TABLE A**

Position	L (mm)	Position	L (mm)
02	10.16	14	71.12
03	15.24	15	76.20
04	20.32	16	81.28
05	25.40	17	86.36
06	30.48	18	91.44
07	35.56	19	96.52
08	40.64	20	101.60
09	45.72	21	106.68
10	50.80	22	111.76
11	55.88	23	116.84
12	60.96	24	121.92
13	66.04		

To convert to inches, divide by 25.4

**EM2565 Series**  
**HORIZONTAL**

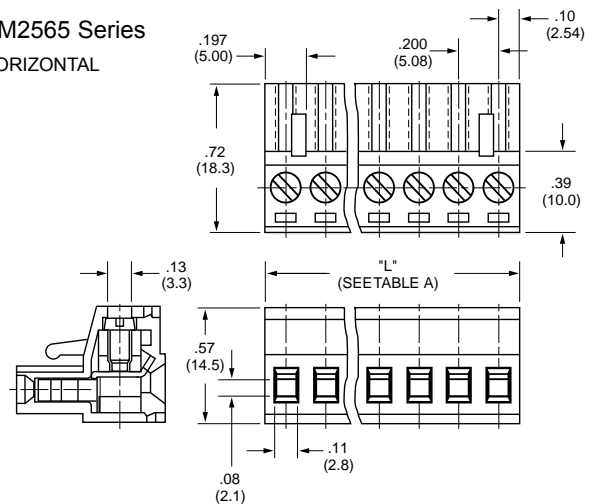

**VERTICAL**

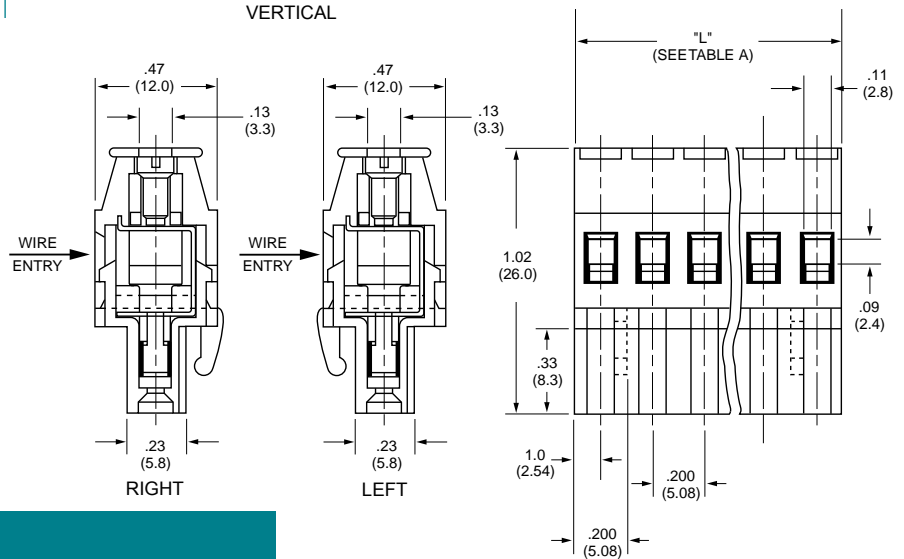

**Part Numbering System**

Series	# of Positions	Orientation	Wire Entry (Vertical Only)
EM2565	nn	n	n
	02 to 24	H - horizontal V - vertical	L - left R - right

# MAGNUM®

## EM2525 Series Euro-Mag Terminal Blocks Depluggable Block (Mates with EM2535 Header), 5.00 Centers

### SPECIFICATIONS

Rating: 15A, 300V  
 Center Spacing: .197" (5.00 mm)  
 Consult factory for .393" (10.0 mm)  
 Wire Size: #12-22 AWG  
 Housing Material: Green Polyamide Type 6/6, 94VO  
 Contact Material: Brass Tin Plated  
 Screw Size: M 3x5 Zinc Plated Steel  
 Operating Temperature: 105°C (221°F) max., -40°C (-40°F) min.  
 Torque Rating: 4.5 in-lb.  
 Construction: Mold to Length

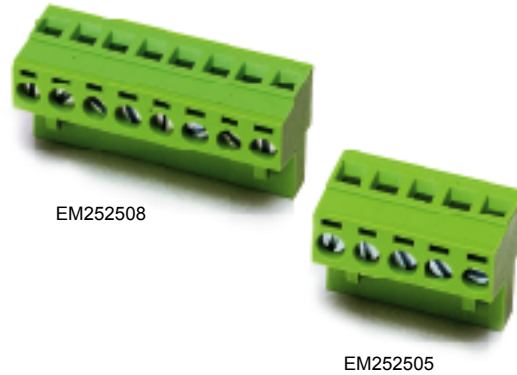
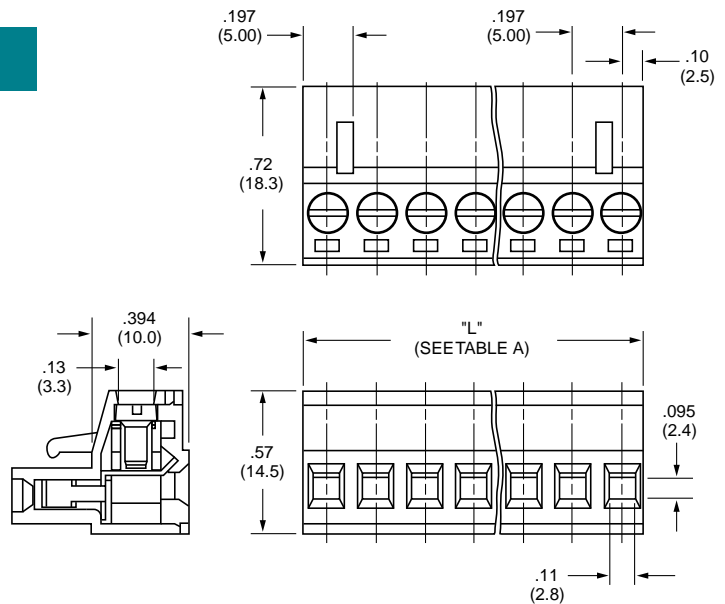

TABLE A

Position	L (mm)	Position	L (mm)
02	10.00	14	70.00
03	15.00	15	75.00
04	20.00	16	80.00
05	25.00	17	85.00
06	30.00	18	90.00
07	35.00	19	95.00
08	40.00	20	100.00
09	45.00	21	105.00
10	50.00	22	110.00
11	55.00	23	115.00
12	60.00	24	120.00
13	65.00		

To convert to inches, divide by 25.4

EM2525 Series



## Part Numbering System

Series # of Positions

EM2525 nn

02 to 24

**EM2465 Series**  
**Euro-Mag Terminal Blocks**

Depluggable Block  
 (Mates with EM2475 Series) 5.00 Centers

**SPECIFICATIONS**

- Rating:** 12A, 300V
- Center Spacing:** .197" (5.00)
- Wire Size:** #14-24 AWG
- Housing Material:** Green Polyamide Type 6/6 94VO
- Contact Material:** Tin Plated Phos Bronze
- Screw Size:** M 2x6, Nickel Plated Steel
- Operating Temperature:** 105°C (221°F) max., -40°C (-40°F) min.
- Torque Rating:** 5.0 in-lb.
- Construction:** Mold to Length
- Agency Approvals:** UL E62622; CSA Pending; CE Certified

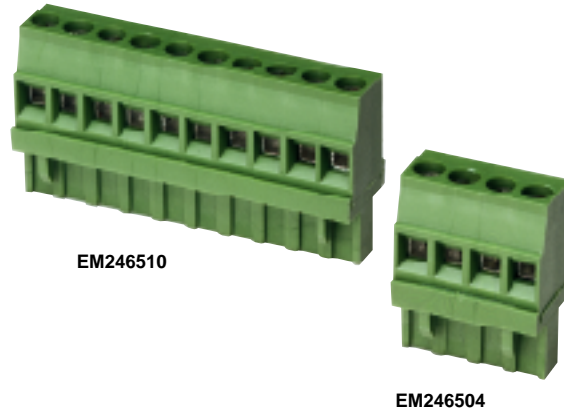
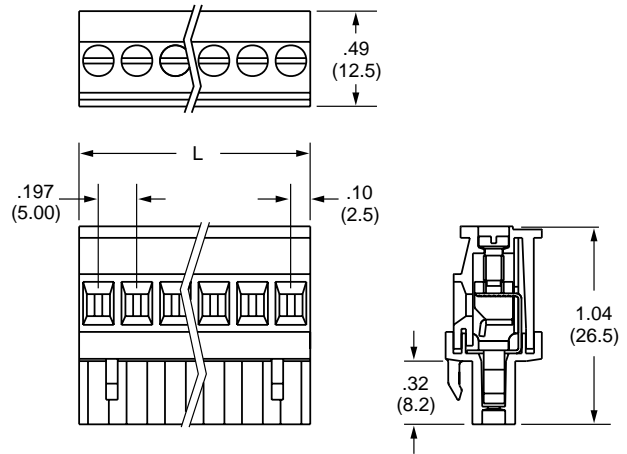

**TABLE A**

Poles	L (mm)	Poles	L (mm)
2	10.00	8	40.00
3	15.00	9	45.00
4	20.00	10	50.00
5	25.00	11	55.00
6	30.00	12	60.00
7	35.00		

To convert to inches, divide by 25.4

**EM2465 Series**



**Part Numbering System**

Series                      # of Positions

**EM2465**      **nn**

**02 to 12**

# MAGNUM®

## EM3563 Series Euro-Mag Terminal Blocks

Depluggable Block (Mates with EM3573 Header), 3.81 Centers

### SPECIFICATIONS

**Rating:** 10A, 125V

**Center Spacing:** .150" (3.81 mm)

Consult factory for .300" (7.62 mm)

**Wire Size:** #18 AWG

**Housing Material:** Green Polyamide Type 6/6, 94VO

**Contact Material:** Brass Tin Plated

**Screw Size:** M 2x3 Zinc Plated Steel

**Operating Temperature:** 105°C (221°F) max., -40°C (-40°F) min.

**Torque Rating:** 3.5 in.-lbs.

**Construction:** Mold to Length

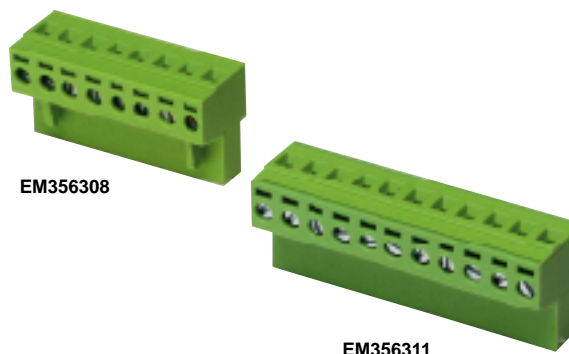
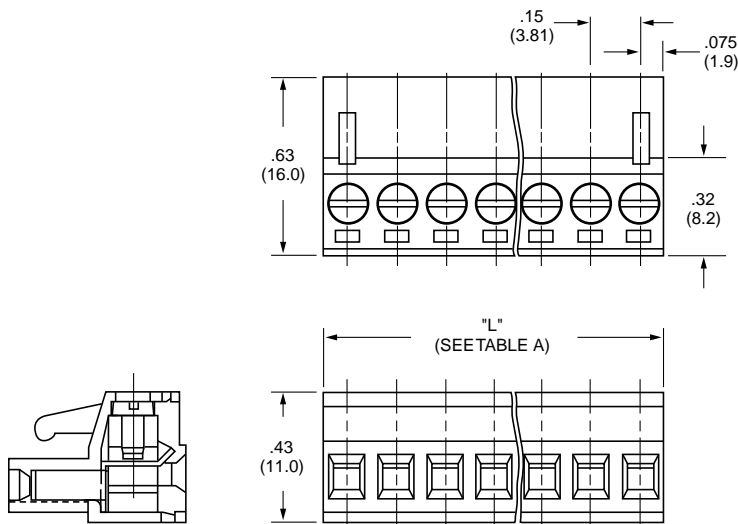

TABLE A

Position	L (mm)
	7.90
02	11.71
03	15.52
04	19.33
05	23.14
06	26.95
07	30.76
08	34.57
09	38.38
10	42.19
11	46.00

To convert to inches, divide by 25.4

EM3563 Series



## Part Numbering System

Series # of Positions

EM3563 nn

02 to 12

## EM5015 Series Euro-Mag Terminal Blocks

Depluggable Block  
(Mates with EM5025 Header) 5.00 Centers

### SPECIFICATIONS

**Rating:** 10A, 300V  
**Center Spacing:** .197" (5.00)  
**Wire Size:** #14-24 AWG  
**Housing Material:** Blue Polyester 94VO  
**Contact Material:** Tin Plated Brass  
**Screw Size:** M 2x6 Chromatized Steel  
**Operating Temperature:** 105°C (221°F) max., -40°C (-40°F) min.  
**Torque Rating:** 3.0 in-lb.  
**Construction:** Modular design features dove-tails for interlocking to achieve longer lengths.  
**Agency Approvals:** UL E62622; CSA Pending; CE Certified



### EM5015 Series

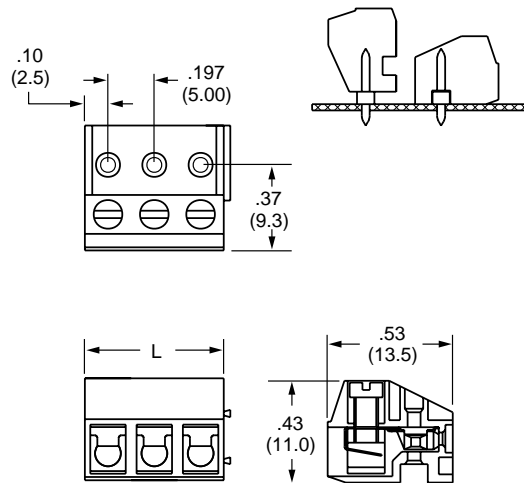

TABLE A

Poles	L (mm)	Poles	L (mm)
2	10.00	14	70.00
3	15.00	15	75.00
4	20.00	16	80.00
5	25.00	17	85.00
6	30.00	18	90.00
7	35.00	19	95.00
8	40.00	20	100.00
9	45.00	21	105.00
10	50.00	22	110.00
11	55.00	23	115.00
12	60.00	24	120.00
13	65.00		

To convert to inches, divide by 25.4

## Part Numbering System

Series                      # of Poles  
**EM5015**                  **nn**  
                                     **02 to 24**

# MAGNUM®

## EM5025 Series Euro-Mag Terminal Blocks

Header (Mates with EM5015 Block),  
5.00 Centers

### SPECIFICATIONS

**Rating:** 10A, 300V

**Center Spacing:** .197" (5.00)

**Housing Material:** Black Polyamide Type 6/6, 94VO

**Contact Material:** Tin Plated Brass

**Operating Temperature:** 105°C (221°F) max., -40°C (-40°F) min.

**Recommended PCB Hole Diameters:** .059" (1.50)

**Construction:** Mold to Length

**Agency Approvals:** UL E62622; CSA Pending; CE Certified

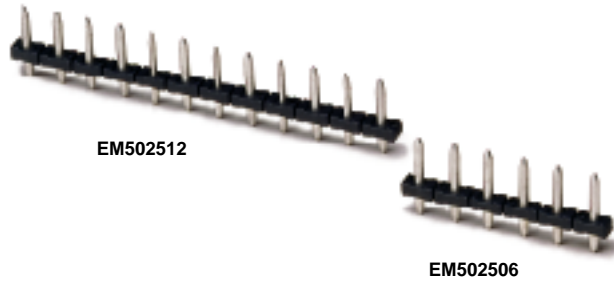
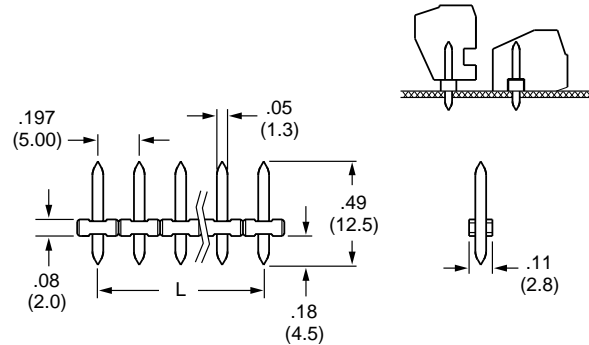

TABLE A

Poles	L (mm)	Poles	L (mm)
2	10.00	14	70.00
3	15.00	15	75.00
4	20.00	16	80.00
5	25.00	17	85.00
6	30.00	18	90.00
7	35.00	19	95.00
8	40.00	20	100.00
9	45.00	21	105.00
10	50.00	22	110.00
11	55.00	23	115.00
12	60.00	24	120.00
13	65.00		

To convert to inches, divide by 25.4

### EM5025 Series



## Part Numbering System

Series # of Poles  
**EM5025** **nn**  
 02 to 24

**EM2575 Series**  
**Euro-Mag Terminal Blocks**  
 Header (Mates with EM2565  
 Depluggable Block), 5.08 Centers

**SPECIFICATIONS**

**Rating:** 15A, 300V  
**Center Spacing:** .200" (5.08 mm)  
 Consult factory for .400" (10.16 mm)  
**Housing Material:** Green Polyamide Type 6/6, 94VO  
**Contact Material:** Brass Tin Plated  
**Operating Temperature:** 105°C (221°F) max., -40°C (-40°F) min.  
**Recommended PCB Hole Diameters:** .055" (1.40)  
**Construction:** Mold to Length  
**Approvals:** UL E62622; CSA LR701941; CE Certified

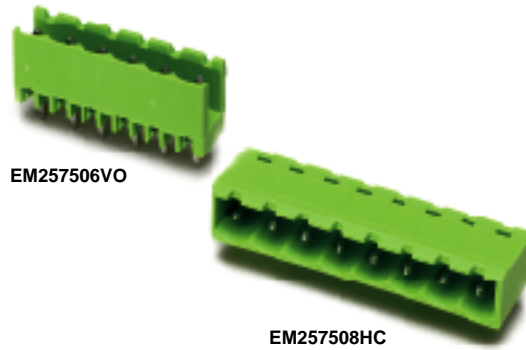
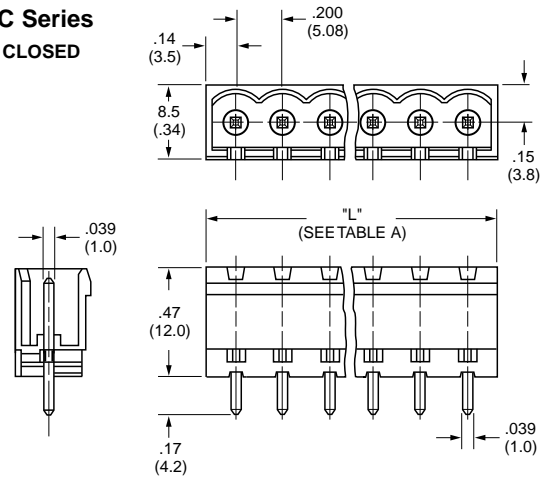

**TABLE A**

Position	Open L (mm)	Closed L (mm)	Position	Open L (mm)	Closed L (mm)
02	10.16	12.08	14	71.12	73.04
03	15.24	17.16	15	76.20	78.12
04	20.32	22.24	16	81.28	83.20
05	25.40	27.32	17	86.36	88.28
06	30.48	32.40	18	91.44	93.36
07	35.56	37.48	19	96.52	98.44
08	40.64	42.56	20	101.60	103.52
09	45.72	47.64	21	106.68	108.60
10	50.80	52.72	22	111.76	113.68
11	55.88	57.80	23	116.84	118.76
12	60.96	62.88		121.92	123.84
	66.04	67.96			

To convert to inches, divide by 25.4

**EM2575VC Series**  
 VERTICAL - CLOSED



**HORIZONTAL - OPEN**

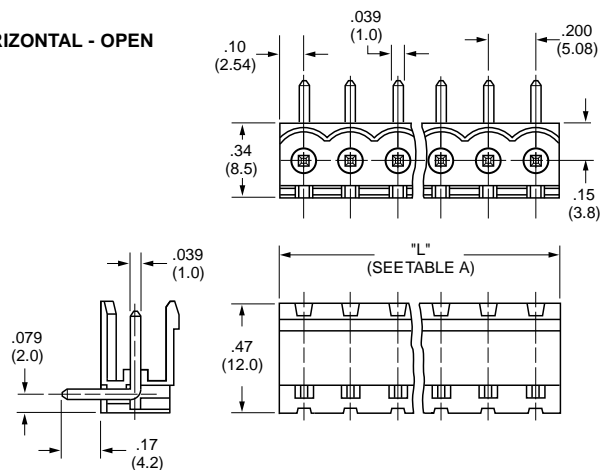

**Part Numbering System**

Series	# of Positions	Orientations	Side Base
EM2575	nn	n	n
	02 to 24	H - horizontal V - vertical	O - open C - closed



# MAGNUM®

## EM2535 Series Euro-Mag Terminal Blocks

Header (Mates with EM2525  
Depluggable Block), 5.00 Centers

### SPECIFICATIONS

**Rating:** 15A, 300V

**Center Spacing:** .197" (5.00 mm)

Consult factory for .393" (10.00 mm)

**Housing Material:** Green Polyamide Type 6/6, 94VO

**Contact Material:** Brass Tin Plated

**Operating Temperature:** 105°C (221°F) max., -40°C (-40°F) min.

**Recommended PCB Hole Diameters:** .055" (1.40)

**Construction:** Mold to Length

**Approvals:** UL E62622; CSA LR701941; CE Certified



TABLE A

Position	Open L (mm)	Closed L (mm)	Position	Open L (mm)	Closed L (mm)
02	10.00	12.00	14	70.00	72.00
03	15.00	17.00	15	75.00	77.00
04	20.00	22.00	16	80.00	82.00
05	25.00	27.00	17	85.00	87.00
06	30.00	32.00	18	90.00	92.00
07	35.00	37.00	19	95.00	97.00
08	40.00	42.00	20	100.00	102.00
09	45.00	47.00	21	105.00	107.00
10	50.00	52.00	22	110.00	112.00
11	55.00	57.00	23	115.00	117.00
12	60.00	62.00		120.00	122.00

To convert to inches, divide by 25.4

### EM2535 Series

#### VERTICAL - CLOSED

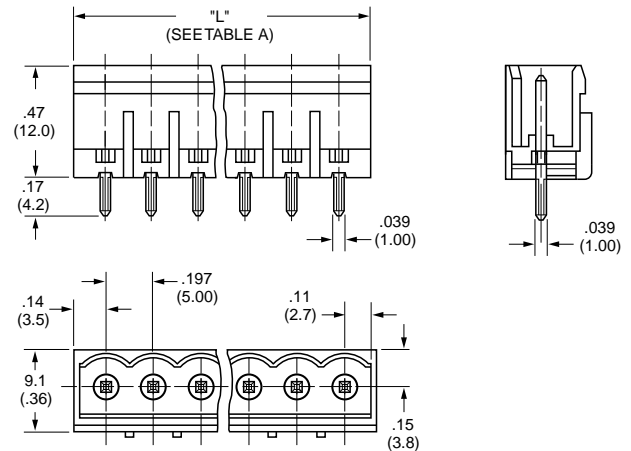

#### HORIZONTAL - OPEN

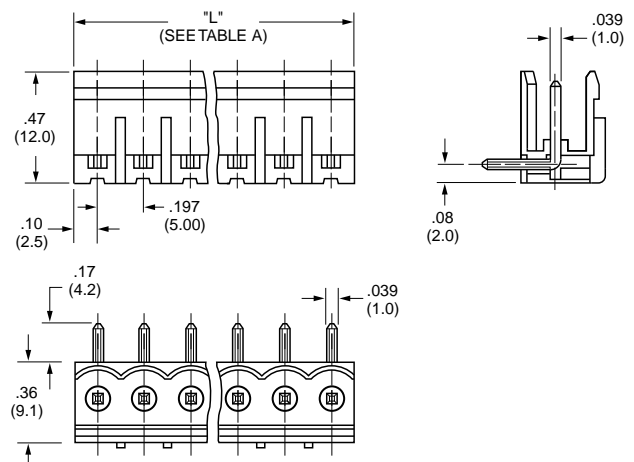

### Part Numbering System

Series	# of Positions	Orientations	Side Base
EM2535	nn	n	n
	02 to 24	H - horizontal V - vertical	O - open C - closed

**EM2475 Series**  
**Euro-Mag Terminal Blocks**  
 Header (Mates with EM2465 Series)  
 5.00 Centers

**SPECIFICATIONS**

**Rating:** 12A, 300V  
**Center Spacing:** .197" (5.00)  
**Housing Material:** Green Polyamide Type 6/6, 94VO  
**Contact Material:** Tin Plated Brass  
**Operating Temperature:** 105°C (221°F) max., -40°C (-40°F) min.  
**Recommended PCB Hole Diameters:** .059" (1.50)  
**Construction:** Mold to Length  
**Agency Approvals:** UL E62622; CSA Pending; CE Certified

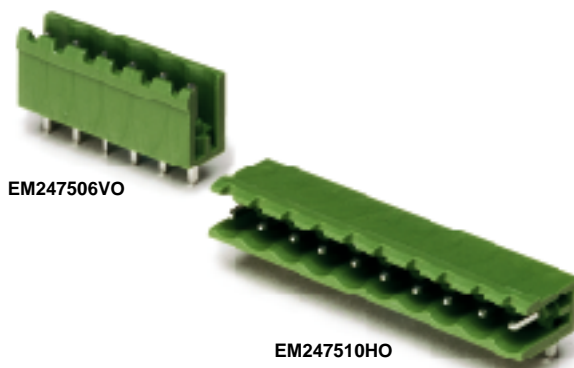
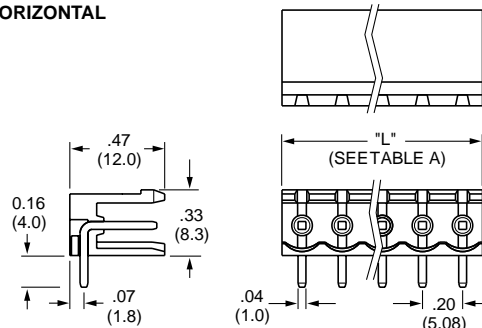

**TABLE A**

Poles	L (mm)	Poles	L (mm)
2	10.16	8	40.64
3	15.24	9	45.72
4	20.32	10	50.80
5	25.40	11	55.88
6	30.48	12	60.96
7	35.56		

To convert to inches, divide by 25.4

**EM2475 Series**  
**HORIZONTAL**



**VERTICAL**

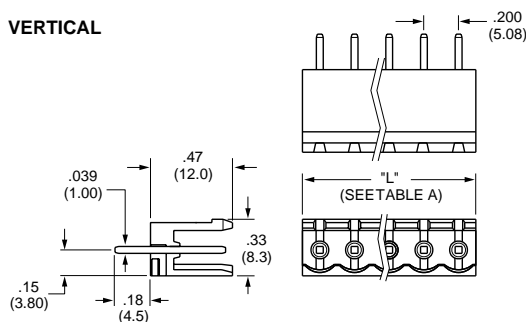

**Part Numbering System**

Series	# of Positions	Orientation	Side Base
EM2475	nn	n	a
	02 to 12	H - horizontal V - vertical	O - Open

# MAGNUM®

## EM3573 Series Euro-Mag Terminal Blocks

Header (Mates with EM3563  
Depluggable Block), 3.81 Centers

### SPECIFICATIONS

**Rating:** 10A, 125V

**Center Spacing:** .150" (3.81 mm)

Consult factory for .300" (7.62 mm)

**Housing Material:** Green Polyamide Type 6/6, 94VO

**Contact Material:** Brass Tin Plated

**Operating Temperature:** 105°C (221°F) max., -40°C (-40°F) min.

**Recommended PCB Hole Diameters:** .055" (1.40)

**Construction:** Mold to Length

**Approvals:** UL & CSA Approvals Pending; CE Certified

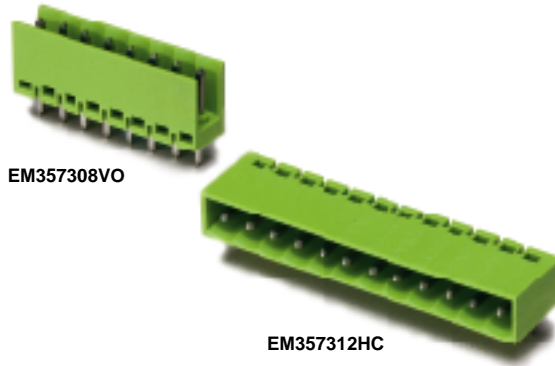
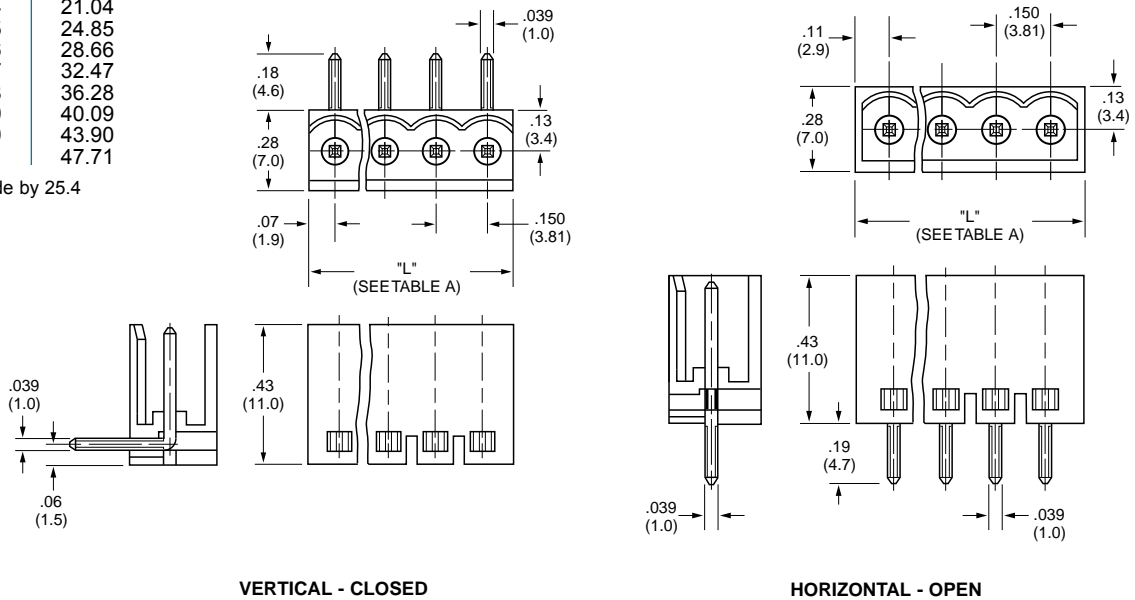

TABLE A

Position	Open L (mm)	Closed L (mm)
02	7.61	9.61
03	11.42	13.42
04	15.23	17.23
05	19.04	21.04
06	22.85	24.85
07	26.66	28.66
08	30.47	32.47
09	34.28	36.28
10	38.09	40.09
11	41.90	43.90
11	45.71	47.71

To convert to inches, divide by 25.4

### EM3573 Series



## Part Numbering System

Series	# of Positions	Orientations	Side Base
EM3573	nn	n	n
	02 to 12	H - horizontal V - vertical	O - open C - closed

**EM7000 Series**  
**Two-Tier Terminal Blocks**  
 7.62 Centers

**SPECIFICATIONS**

- Rating:** 15A, 300V
- Center Spacing:** .300" (7.62)
- Wire Size:** #16-22 AWG
- Housing Material:** Black, UL Rated 94VO Thermoplastic
- Contact Material:** Tin Plated Brass
- Screw Material:** M 3x0 Nickel Plated Steel
- Operating Temperature:** 105°C (221°F) Max., -40°C (-40°F) min.
- Torque Rating:** 9 in-lb.
- Recommended PCB Hole Diameters:** .051" (1.30)
- Construction:** Mold to Length
- Agency Approvals:** UL E62622; CSA Pending; CE Certified



EM713710



EM711706



EM712708

Poles	L (mm)	S (mm)
2	21.2	7.62
3	28.8	15.24
4	36.4	22.86
5	44.0	30.48
6	51.6	38.10
7	59.3	45.72
8	66.9	53.34
9	74.5	60.96
10	82.1	68.58
11	89.7	76.20
12	97.4	83.82
13	105.0	91.44
14	112.6	99.06
15	120.2	106.68
16	127.8	114.30

To convert to inches, divide by 25.4

**EM7117 Series**

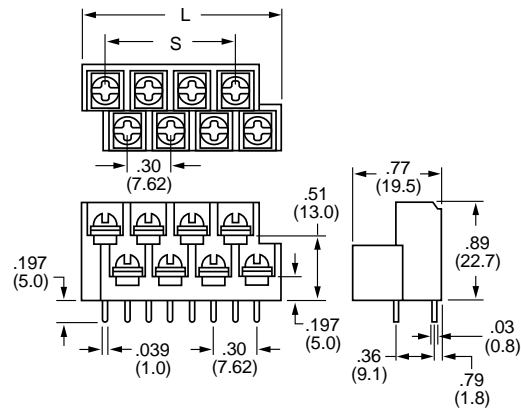

**EM7127 Series**

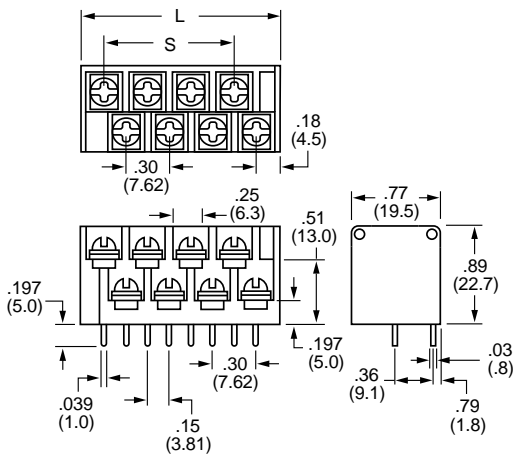

**EM7137 Series**

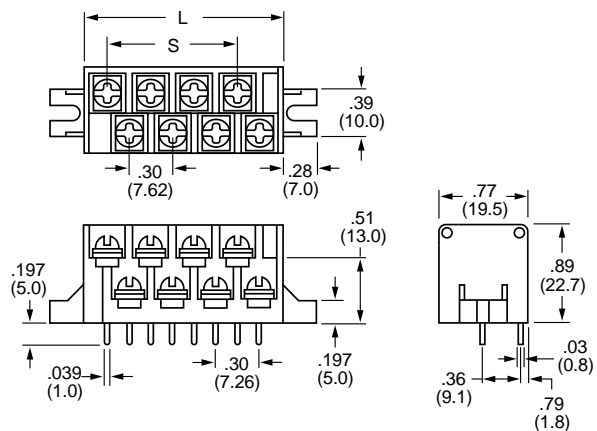

**Part Numbering System**

Series	Poles	Options
EM - nnnn - nn	2 - 16	n
7117		WC - with cover
7127		(EM7127 & EM7137
7137		Series only)

# MAGNUM®

## Series 15133

Depluggable PCB Mount  
Terminal Blocks

### SPECIFICATIONS

- Rating:** 20A, 300V
- Center Spacing:** .375" or 3/8" (9.52 mm)
- Wire Size:** #12-22 AWG CU
- PC Board:** For soldering to PCB (.00015" tin over copper flash)
- Material:** Black, UL Rated 94VO Thermoplastic
- Screws:** #6-32 Zinc plated steel SEMS
- Terminals:** 15133-XX-10-X – Tin or gold plated brass  
15133-XX-20-X – Nickel or gold plated copper alloy plug terminal, tin or gold plated female terminal
- Operating Temperature:** 221°F (105°C)
- Approvals:** UL E62622; CSA LR15364; CE Certified

The 15133 is a series of input/output circuit board connectors. Available in a 1-piece or 2-piece design, they stack side-by-side with self-aligning housings to prevent incorrect mating. Both designs feature an integral, living hinge cover that saves the labor of attaching a separate cover. The cover provides a dead front for prevention of electrical accidents, yet it also has test probe holes for easy circuit testing.

The 1-piece design is for applications not requiring unplugging the connector. It solders to the printed circuit board. Molded stand-offs ensure good solderability.

The 2-piece design enables quick connect and disconnect of several circuits at once. It allows fast board changing in the field without shutting down the entire system. The bottom section of the connector solders to the board. Male contacts are shrouded while the female has stand-offs; both are molded into the block. The top section of the connector plugs into the bottom section.



15133-XX-10-X

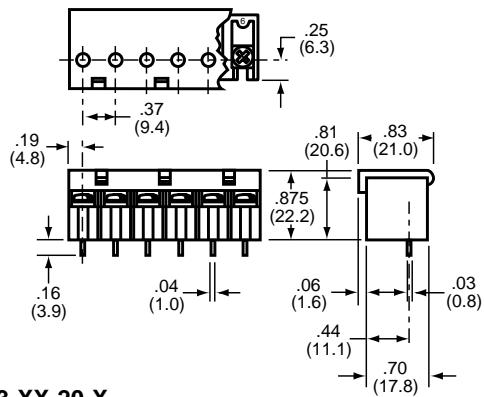

15133-XX-20-X

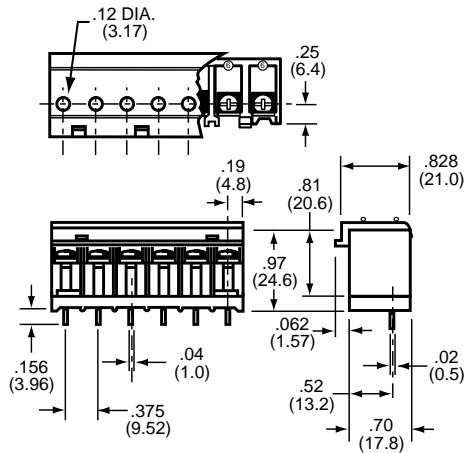

## Part Numbering System Inches (Millimeters)

Series	Poles	Style	Mounting	Terminal Plating
15133	nn 02 to 10	n 1 - One piece 2 - Two piece	n 0 - No mtg. holes	n T - Tin G - Gold (.00015 min.) over nickel (.00003) overall

**Series 13926**

**Edge Connectors – 2 Sided Boards**

**SPECIFICATIONS**

**Rating:** 8A max., 250V

**Center Spacing:** .200" (5.08 mm)

**Wire Size:** #12-22 AWG CU; entry to PC board at 90° angle

**PC Board:** Edge contact accepts standard 1/16" (.0625) PCB.

**Contacts:** Tuning fork design .021" thick phosphorus bronze with mating surface gold plated (.000030) over nickel (.000100) tin plated (.000200) over copper (.000050). Contact engagement and separation forces per MIL-C-21097.

**Material:** White, UL Rated 94VO Glass Filled Polyester (130°C).

Pole designations printed in black epoxy ink.

**Operating Temperature:** -20°C to 100°C

**Approvals:** UL E62622 for commercial appliance applications up to 250 volts and general industrial applications up to 150 volts. CE Certified

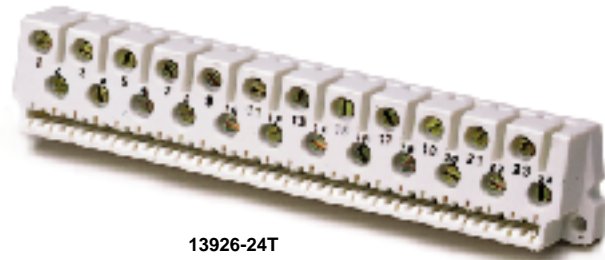

13926-24T

**13926 Series**

Inches (mm)

Poles	A	B	C	D	E	F
12	2.91	11	2.20	2.31	2.66	2.61
18	4.11	17	3.40	3.50	3.86	3.81
24	5.31	23	4.60	4.70	5.06	5.01
25	5.51	24	4.80	4.90	5.26	5.21
30	6.51	29	5.80	5.90	6.26	6.21
36	7.71	35	7.00	7.10	7.46	7.41

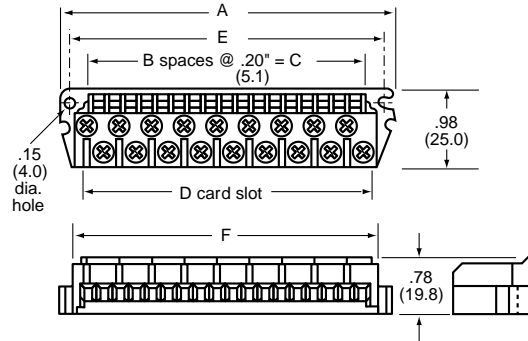

\* Dimensions in inches. To convert to millimeters, multiply by 25.4. Optional polarizing key (Part No. C5952); consult factory.

**Part Numbering System** Inches (Millimeters)

<b>Series</b>	<b>Poles</b>	<b>Terminal Plating</b>
13926	- nn	n
	12	T - Tin over copper
	18	
	24	
	25	
	30	
	36	

# MAGNUM®

## Series 1384X

Edge Connectors –  
1 Sided Boards/Vertical Mount

### SPECIFICATIONS

**Rating:** 10A, 250V

**Center Spacing:** .375" or 3/8" (9.52 mm)

**Wire Size:** #14-22 AWG CU; entry to PC board at 90° angle.

**PC Board:** Edge contact accepts standard 1/16" (.0625) PCB.

**Contacts:** Cantilever design .020" thick phosphorus bronze with mating surface gold plated (.000030) over nickel (.000100) tin plated (.000200) over copper (.000050).

**Terminals:** Pressure plate terminals.

**Material:** Black, UL Rated 94VO Thermoplastic (125°C)

**Operating Temperature:** -55°C to 105°C (212°F)

**Approvals:** UL E62622; CSA LR15364; CE Certified

13848-08G02B



13847-08TO2B



Poles	A	B	C	D
04	2.25	1.87	1.12	1.53
05	2.62	2.25	1.50	1.90
06	3.00	2.62	1.87	2.28
07	3.37	3.00	2.25	2.65
08	3.75	3.37	2.62	3.03
09	4.12	3.75	3.00	3.40
10	4.50	4.12	3.37	3.78
11	4.87	4.50	3.75	4.15
12	5.25	4.87	4.12	4.53
13	5.62	5.25	4.50	4.90
14	6.00	5.62	4.87	5.28
15	6.37	6.00	5.25	5.65
16	6.75	6.37	5.62	6.03

### 1384X Series

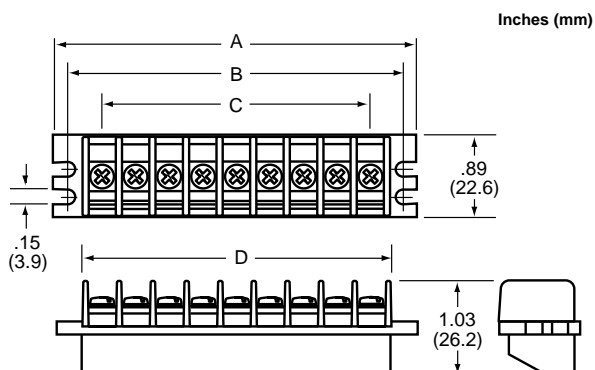

\* Dimensions in inches. To convert to millimeters, multiply by 25.4.  
Optional polarizing key (Part No. C5971) consult with factory.

## Part Numbering System

Series	Block Style	Poles	Terminal Plating	Screw Style	Block Color	Special Options
1384X	n - 7 - Flat mtg. ears w/ 2 slots 8 - Mtg. ears w/2 standoffs with hole for mounting strip	nn 04 to 16	n T - Tin over copper G - Gold over nickel	02 02 - #6-32 pan head. w/ SEMS wire clamp	B B - Black	n M - Marking strip



## Series 15104

### Edge Connectors – 1 Sided Boards / Right Angle Mount

#### SPECIFICATIONS

**Rating:** 10A, 300V

**Center Spacing:** .375" or 3/8" (9.52 mm)

**Wire Size:** #12-22 AWG CU

**Terminals:** Pressure plate terminals with screws set at 45° or 90° angle

**PC Board:** Edge contact accepts standard 1/16" (.0625) PCB

**Contacts:** Tuning fork design of .021" thick phosphorus bronze with .0001" bright tin plating or .000015" gold plate over .00003" nickel

**Material:** Black, UL Rated 94VO Thermoplastic

**Operating Temperature:** 95°C max.

**Approvals:** UL E62622; CSA LR15364; CE Certified

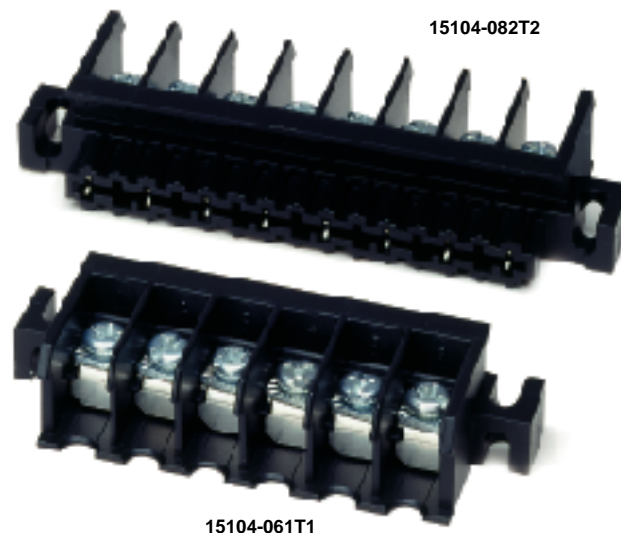

Poles	A	B	C	D	E	Board Width
06	3.00	2.62	2.00	2.16	2.36	1.99
08	3.75	3.37	2.75	2.91	3.11	2.74
10	4.50	4.12	3.50	3.66	3.86	3.49
12	5.25	4.87	4.25	4.41	4.61	4.24
14	6.00	5.62	5.00	5.16	5.36	4.99
16	6.75	6.37	5.75	5.91	6.11	5.74
18	7.50	7.12	6.50	6.66	6.86	6.49
20	8.25	7.87	7.25	7.41	7.61	7.23
22	9.00	8.62	8.00	8.16	8.36	7.98
24	9.75	9.37	8.75	8.91	9.11	8.73
26	10.50	10.12	9.50	9.66	9.86	9.48
28	11.25	10.87	10.25	10.41	10.61	10.23

\* Dimensions in inches. To convert to millimeters, multiply by 25.4.  
Integral standoffs for mounting marker strips - consult factory.

#### 15104 Series

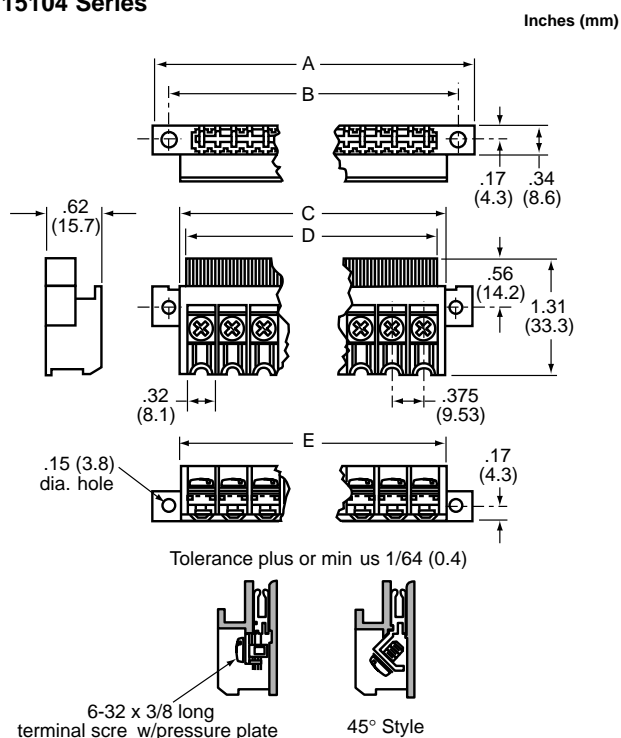

### Part Numbering System

Series	Poles	Terminal	Plating	Screw
15104	nn	n	n	n
	06 to 28 (Increments of 2)	1 - 90° angle 2 - 45° angle	T - Tin G - Gold	1 - #6-32 pan head. w/wire clamp

# MAGNUM®

## Series 7000

### MAG-MASTER® Electronic/Field Wiring Interfaces

#### SPECIFICATIONS

**Rating:** 3 or 5A, 250V. Terminal style determines max. current, consult factory for details. Flat ribbon connectors are rated at 1 Amp per circuit.

**Terminals:** Field wiring terminals have bright zinc plated steel screws on .325" centers in two rows. #6-32 screws accept #14-22 AWG CU wire and .250" wide wire lugs.

**Material:** Black, UL Rated 94VO Thermoplastic

**Operating Temperature:** 105°C continuous

**Approvals:** UL E62622; CE Certified

**Fast:** Convenient connecting of field wiring to edge card, pin type, flat ribbon and sub-miniature D connectors.

**Economical:** No need to fabricate special adapting devices. Saves design and production time, QA/QC, field labor and reduces overall installed cost.

**Versatile:** Choose from six standard MAG-MASTER® interfaces offering interfaces for up to 60 circuits.

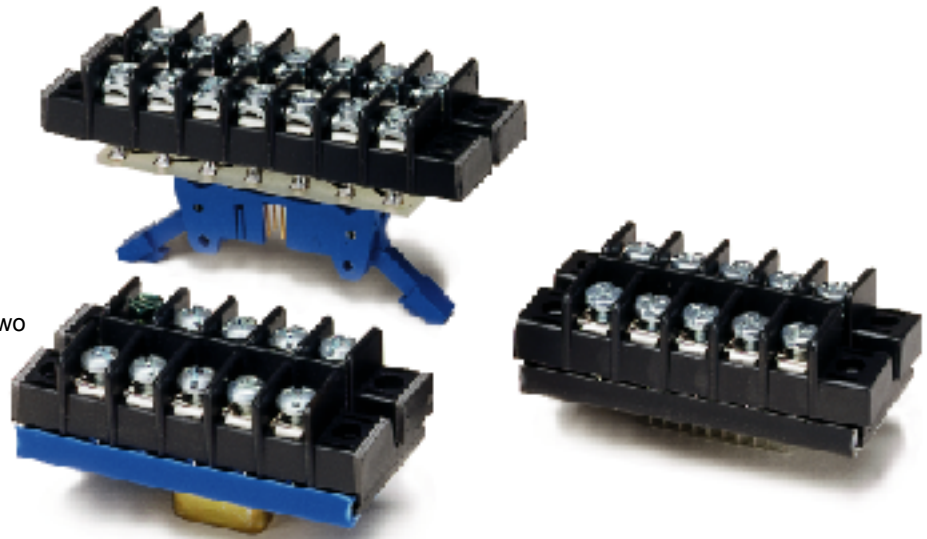

## Part Numbering System

**Series**

**n**

**Connector**

**nn**

- 14 - subminiature D male
- 15 - subminiature D female
- 22 - .100 x .100 flat cable long latc
- 30 - .100 centers mass wiring header
- 32 - .156 centers mass wiring header

**Circuits\***

**nn**

- 08, 09, 10,
- 14, 15, 16,
- 20, 24, 25,
- 26, 30, 32,
- 34, 37, 40
- 50

\* Circuit sizes vary by connector style.

**Options**

**nn**

- 01 - Green hex
- 07 - Steel Sems
- JA, JB & JC - Jumpers
- B7 - B9 - .187" QC
- TL - Fixed thread lock #4-40 (for connector types 14 & 15 only)

Marker strips - Contact factory  
Special orientations - Contact factory

**Type 14 - Subminiature D Male**

Marking (if required) will identify ground screw and contacts.

**Type 15 - Subminiature D Female**

Marking (if required) will identify ground screw and contacts.

Circuits	A Overall Length	B Mount Centers	C Connector Length	D Mnt. Holes To Connector	E Male	E Female
09	2.34	1.95	1.22	0.36	0.70	0.64
15	3.32	2.92	1.54	0.69	1.03	0.97
25	4.94	4.55	2.09	1.23	1.57	1.51
37	6.89	6.50	2.74	1.88	2.22	2.16

Dimensions in inches. To convert to millimeters, multiply by 25.4.

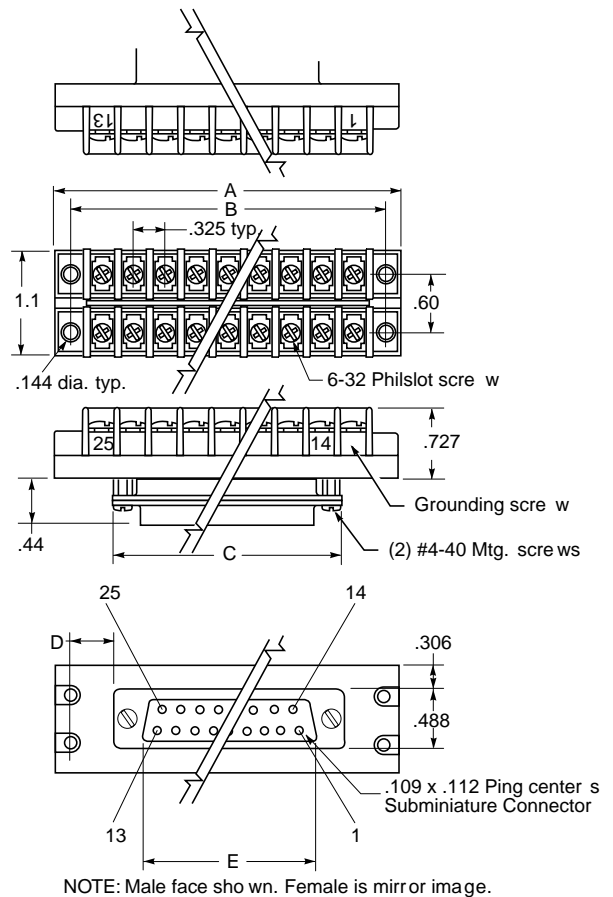

**Type 22 - .100 x .100 Centers Flat Cable with Long Latch**

Circuits	A Overall Length	B Mount Centers	C Connector Length	D Mount Holes To Connector
10	2.34	1.95	1.26	.345
14	2.99	2.60	1.46	.570
16	3.31	2.92	1.55	.682
20	3.96	3.57	1.76	.908
26	4.94	4.55	2.05	1.24
34	6.24	5.85	2.46	1.69
40	7.21	6.82	2.76	2.03
50	8.84	8.45	3.26	2.59

Dimensions in inches. To convert to millimeters, multiply by 25.4.

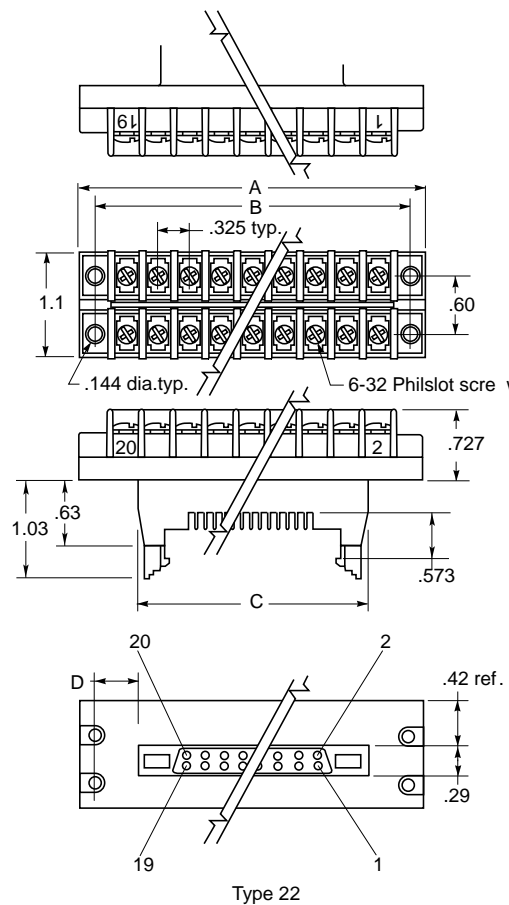

# MAGNUM®

## Type 30 - .100 Centers Mass Wiring Headers

Circuits	A Overall Length	B Mount Centers	C Connector Length	D Mount Holes To Connector
08	2.02	1.62	0.80	0.41
10	2.34	1.95	1.00	0.48
16	3.32	2.92	1.60	0.66
20	3.97	3.57	2.00	0.79
24	4.62	4.22	2.40	0.91
30	5.59	5.20	3.00	1.10

Dimensions in inches. To convert to millimeters, multiply by 25.4.

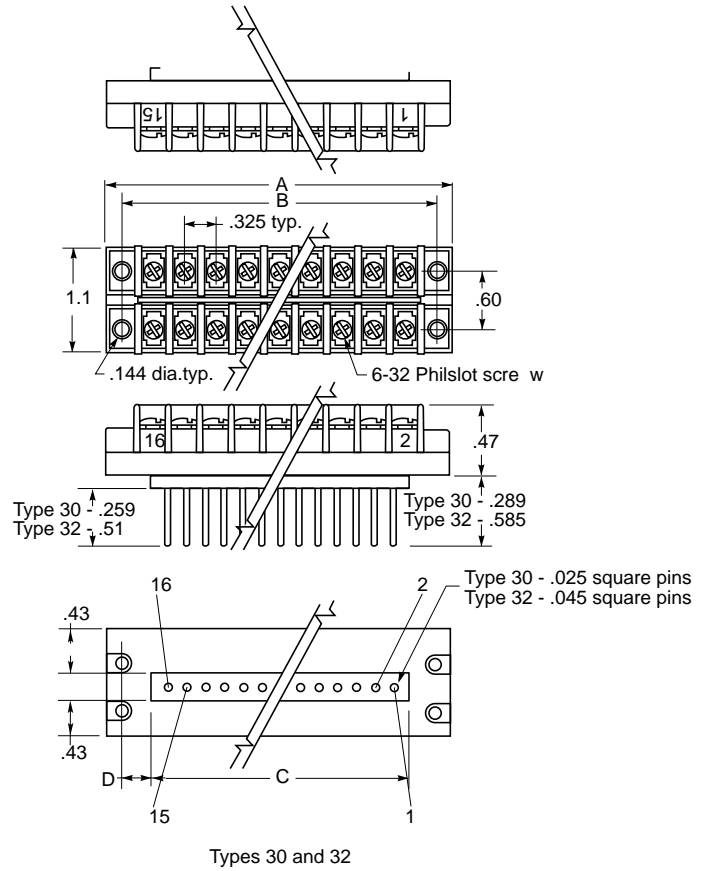

## Type 32 - .156 Centers Mass Wiring Headers

Circuits	A Overall Length	B Mount Centers	C Connector Length	D Mount Holes To Connector
16	3.32	2.92	2.50	0.21
24	4.62	4.22	3.74	0.24
32	5.92	5.52	4.99	0.27
40	7.22	6.82	6.24	0.29

Dimensions in inches. To convert to millimeters, multiply by 25.4.

Series 7000 MAG-MASTER® Continued

Screw Options



03  
Stainless Steel



07  
Steel SEMS  
Zinc Plated

Hardware Options (Bulk ordering part numbers are in parentheses.)

Jumpers

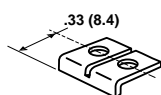

JA (JA1-XX)

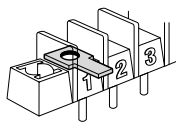

B7 (1B7)

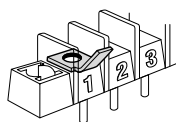

B8 (1B8)

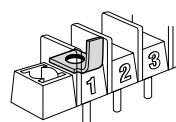

B9 (1B9)

Quick Connects Blade Width B = .187".  
(For other orientations, contact factory.)

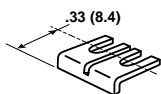

JB (JB1-XX)

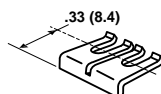

JC (JC1-XX)

Marker Strips

Optional Marker Strips are available for MAG-MASTER® in the two styles of marking shown here. The strips install with the mounting screws under the terminal block extending beyond the sides of the block. Shipped in pairs, unassembled.

To order, specify MS followed by MAG-MASTER® part no. and style desired. Example: MS722120-1. If special markings are required, submit a drawing.

DO NOT ADD STYLE NO. FOR MARKER STRIPS USED WITH TYPE 14 AND TYPE 15 (D-SUBMINIATURE CONNECTORS). MARKING WILL CORRESPOND TO CONTACT NUMBERS ON CONNECTOR.



Style 1

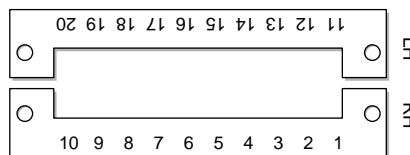

Style 2

# MAGNUM®

## Custom Capabilities

---

*For over 50 years, MAGNUM's key strength has been designing custom products for the electronic and electrical markets.*

*Once a product need is identified, an innovative team of design engineers works closely with the customer to discuss their needs. This enables our team to design and develop custom products tailored to meet specific customer requirements.*

### **MAGNUM helps you get a jump on the competition!**

*By utilizing an in-house Model Shop and state-of-the-art technology such as advanced computer aided design (CAD) and ProE, MAGNUM has the ability to reduce the time it takes to move from a concept to a prototype. Functional prototypes are available in weeks, not months, which enables our customers to get a jump on their competition. Our design engineers also take advantage of electronic mail to transfer files back and forth, which greatly reduces time in the design process.*

*MAGNUM also utilizes a complete in-house UL and CSA qualified testing facility. This saves our customers valuable time and money by eliminating the costly expense and red tape involved in gaining agency approvals.*

*Over the years, MAGNUM engineers have registered hundreds of patents. The following are a few examples of custom products the MAGNUM team has developed for our valued customers:*

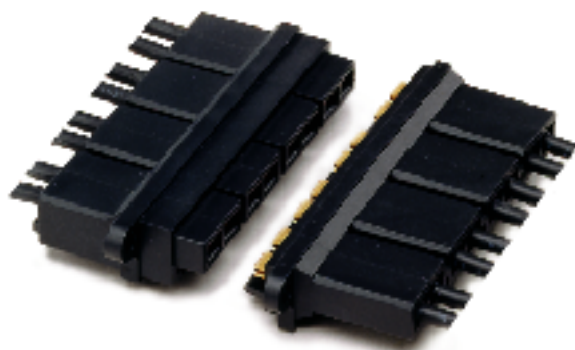

### **Power Connector**

This power connector is used in utility substations and allows safe, uninterrupted electricity flow to a protective relay. This block saved our customer 30% in cost and was more reliable than the competitor's block.



### Back Housing for PLC

This custom product is primarily used in the chemical refinement and food processing industries. The removable wire connectors, which were previously not available, allow for easy installation for the end user.

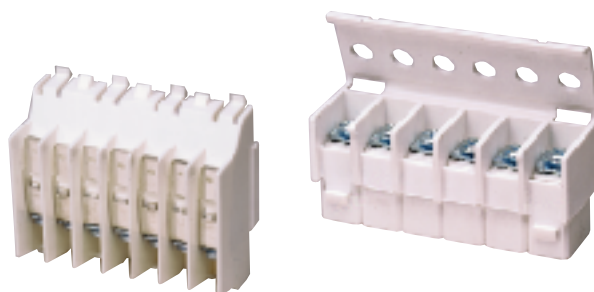

### Quick Connect Power Connector / Power Junction Block

These blocks are used in a serviceable circuit breaker unit. The triple quick connect power connector is capable of carrying 30 Amps, 300 Volts. Both blocks saved our customer 20% in cost while reducing the overall connector count in the unit.

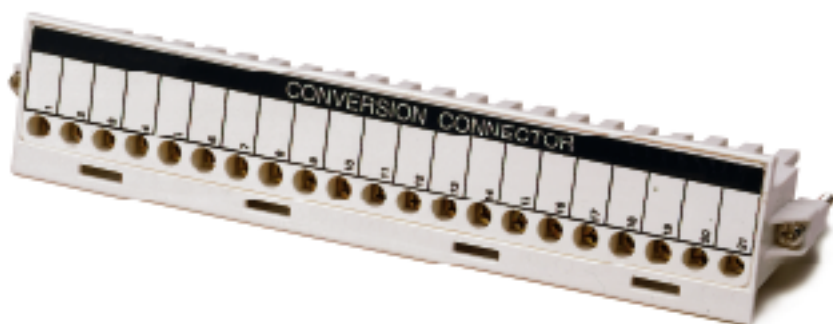

### Dead-Front Connector

This dead-front connector is used as an I/O device in industrial systems to manage controlling equipment, motors, and HVAC equipment. It took MAGNUM's design engineers only 5 months to design the connector, develop prototypes, and release parts for production tooling.



### Edgcard Connector

This edgcard connector interfaces with a double-sided printed circuit board. It is used as a fault indicator for power transmission substations.



# MAGNUM®

## Cooper Bussmann Compliance References

### UL 1059 Basic Voltage Rating

Voltage ratings of terminal blocks are based on the minimum spacing between electrical conductive parts of opposite polarity or between an electrically conductive part and a metal mounting surface measured under two conditions: Through Air, defined as the distance an arc must take through air to go from one live conductor to another or from a live conductor to ground; and Over Surface, defined as the distance an arc must take over the surface of the insulating material going from one terminal to ground, assuming the arc will travel along the surface rather than through the air. The following chart shows UL 1059 spacing requirements, in inches.

	Voltage	Spacing Thru Air	Requirements Over Surface
<b>Class A</b>			
Service equipment including panel boards, deadfront switchboards, service entrance devices, etc.	51-125 126-250 251-600	.50 .75 1.00	.75 1.25 2.00
<b>Class B</b>			
Commercial appliances including business equipment, electronic data processing equipment and the like.	51-125 126-250 251-600	.06 .09 .38	.06 .09 .50
<b>Class C</b>			
General industrial and machine tool controls which can be further defined as equipment falling under UL508.	51-150 151-300 301-600	.12 .25 .38	.25 .38 .50

### UL and CSA Compliance

Magnum® Terminal Blocks comply fully with UL 1059 and UL 94VO self-extinguishing classification. The blocks are recognized under UL file no's. E48580 and E62622 and CSA no's. LR28145 and LR15364. Note: UL ratings higher than those listed are possible and can vary, depending upon the application. Requests for higher ratings are considered by UL on an individual basis. Where UL or CSA listings are required, it is usually easier to gain approvals on feed-thru blocks that have insulator bases.

### IEC Compliance

Most Magnum® Terminal Blocks comply with the requirements in IEC Publication 947-7-1 Low Voltage Switchgear and Controlgear. These blocks are concurrently Recognized and Certified under the UL Classification Program. Ratings, except where indicated, are concurrent with UL 1059.

### ISO

In 1994, Cooper Bussmann achieved certification to ISO 9001, the most stringent set of quality system standards set forth by the international organization for standards. We are committed to quality performance at all levels of the organization.

### CE

In 1998, Cooper Bussmann received CE certification on all MAGNUM products. CE is a self-certification on product safety and performance and is required for free movement of product into the European market.

### Suitability of Magnum® Terminal Block Series under UL 1059

Use this chart for quick, easy Magnum series selection for your application. Some Magnum blocks have more than one voltage rating depending on the end use application as indicated here.

MAGNUM® Series	Class A			Class B			Class C		
	51-125 Volts	126-250 Volts	251-600 Volts	51-125 Volts	126-250 Volts	251-600 Volts	51-150 Volts	151-300 Volts	301-600 Volts
1000	No	No	No	Yes	Yes	No	Yes	No	No
2000*	No	No	No	Yes	Yes	No	Yes	Yes	No
3000*	No	No	No	Yes	Yes	Yes	Yes	Yes	Yes
4000*	Yes	No	No	Yes	Yes	Yes	Yes	Yes	Yes
5000*	No	No	No	Yes	Yes	No	Yes	Yes	No
7000	No	No	No	Yes	No	No	Yes	No	No
TB100*	No	No	No	Yes	Yes	No	Yes	No	No
TB200*	No	No	No	Yes	Yes	No	Yes	Yes	No
TB200HB*	No	No	No	Yes	Yes	Yes	Yes	Yes	Yes
TB300*	No	No	No	Yes	Yes	Yes	Yes	Yes	Yes
TB400	No	No	No	Yes	Yes	Yes	Yes	Yes	Yes

\* With certain options, ratings may vary – consult factory.





MAGNUM, formerly known as Bussmann Circuit Components, is a stand-alone operating unit of Cooper Bussmann. MAGNUM, located in Chicago, IL, manufactures the most complete selection of terminal blocks including North American and European style terminal blocks, DIN rail sectional blocks, and power distribution blocks. Along with this wide range of terminal blocks, MAGNUM also manufactures circuit protection devices, disconnect switches and custom products for the electronic, electrical, and automotive markets.

With over fifty years of exceptional service and quality products, MAGNUM continues to be a world leader in the terminal block market. We believe in building long-term relationships with our customers and strive to exceed all expectations through superior customer service, quality products, and continuous improvement.



### CUSTOMER SERVICE

All MAGNUM team members take pride in their work to provide our customers with superior products and service. At MAGNUM, we work as a team to satisfy our customers and will go that extra mile to meet our customers' needs! Qualified professionals process all communications, inquiries, quotations, and purchase orders while coordinating the scheduling and shipping to ensure on-time delivery. We strive to maximize productivity, minimize problems, and assure our customers of high quality products and service. Our innovative team of design engineers will design and develop products for any applications and our knowledgeable technical staff is available to help you with all your product needs. MAGNUM is the only source you need for quality products and superior customer service.



### QUALITY

MAGNUM's commitment to providing quality products and service is apparent at all levels of the production process. In 1994, MAGNUM was awarded ISO9001 certification which encompasses all functional areas of our business including design and development, purchasing, production, quality control and customer service. Along with ISO certification, MAGNUM also complies to UL, CSA, VDE, IEC, SAE, and CE standards. In addition, MAGNUM utilizes and maintains a complete in-house lab facility for performing UL, CSA, and IEC qualification testing. This saves valuable time and money by eliminating the costly expense and procedures involved in gaining agency approvals. With MAGNUM, you can be assured to receive the highest quality in interconnection products.



### CONTINUOUS INNOVATION

At MAGNUM, we are continually searching for new ways to improve our products and processes to provide our customers superior value. Customers can transmit orders and expedite through EDI, which saves time and eliminates unnecessary paperwork. Our design engineers utilize state-of-the-art technology and design software which provides a quick turn-around time for product designs and prototypes. Our manufacturing team currently uses Kan Ban and JIT processes to ensure on-time delivery of all MAGNUM products. Let MAGNUM show you how fifty years of experience and continuous innovation can have a positive impact on your business!

***Get Connected With MAGNUM!***

Look for other reliable products  
from Cooper Bussmann  
in these comprehensive catalogs . . .

## Circuit Protection

Products for DC mobile and AC supplementary circuit protection requirements including Shortstop®, Flat-Pak® and Hi-Amp™ auto, manual or modified reset and switchable circuit breakers, Maxi®, ATC®, ATM® blade type circuit protectors, Stud Type Junction Blocks, Blade type Fuse Panels and Battery Disconnect Switches.

## Wire Management Products

A wide array of wire management products in one, easy-to-use selection guide. 35mm DIN and C-Rail type barrier style blocks in splicer, quick-connect, depluggable, and fused versions, as well as base mountable sections; Power Distribution blocks for higher current capacity in multiple load, splicer, and studded versions; MAGNUM Double Row terminal blocks and accessories; Junction Blocks in both surface mount and feed-through single stud styles; Photo Control Receptacles; and Non-fused Disconnect blocks.

**MAGNUM®**

COOPER BUSSMANN • 7300 W. Wilson Ave. • Chicago, IL 60656-4708 • Fax: 708-867-2211 • Phone: 708-867-4600  
Website: <http://www.busscc.com>