



10-output, 400-MHz LVPECL Zero Delay Buffer

Features

- 400-ps max Total Timing Budget™ (TTB™) window
- 10 LVPECL outputs
- 1 LVPECL differential input
- Selectable output frequency range from 100 to 400 MHz
- Multiply by 2 option
- 15-ps RMS Cycle-Cycle Jitter
- Power-down mode
- Lock indicator
- 3.3V power supply
- Available in 48-pin QFN package

Overview

The CY23020-3 is a high-performance 400-MHz LVPECL Output phase-locked loop (PLL)-based zero delay buffer (ZDB) designed for high-speed clock distribution applications. The device features a guaranteed TTB window specifying all occurrences of output clocks with respect to the input reference clock across variations in voltage, temperature, process, frequency, and ramp rate.

Additionally, the CY23020-3 can be used as a fan-out buffer via the S[1:2] control pins. In this mode, the PLL is bypassed and the reference clock is routed to the output buffers.

Block Diagram

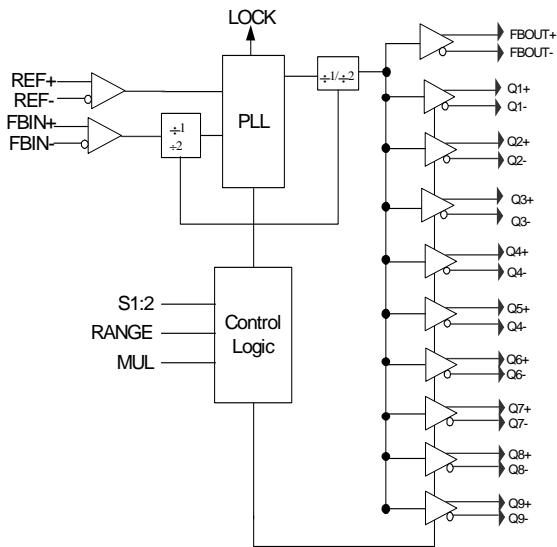

Pin Configurations

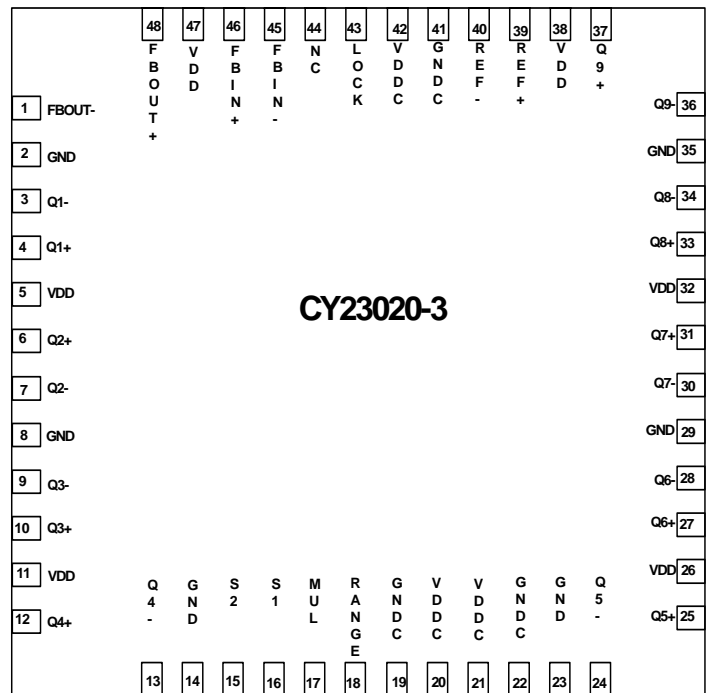

Pin Definitions^[1]

Pin Name	Pin No.	Pin Type	Pin Description
REF+ REF-	39 40	I	Reference Inputs. Output signals are synchronized to the crossing point of REF+ and REF- signals. In DC mode, the REF+/REF- inputs must be held at opposite logical states. For optimal performance, the impedances seen by these two inputs must be equal.
FBIN+ FBIN-	46 45	I	Feedback Inputs. Input FBIN+/FBIN- must be fed by one of the outputs to ensure proper functionality. If the trace between FBIN+/FBIN- and FBOUT+/FBOUT- is equal in length to the traces between the outputs and the signal destinations, then the signals received at the destinations will be synchronized to the clock signal at REF+/REF- inputs. In DC mode, FBIN+/FBIN- inputs must be held at opposite logical states. For best performance, the impedances seen by these two inputs must be equal.
FBOUT+ FBOUT-	48 1	O	Feedback Output. In order to complete the phase locked loop, similar polarity outputs must be connected back to the FBIN+ and FBIN- pins. Any of the outputs may actually be used as the feedback source.
Q1+, Q1-	4, 3	O	Differential Q1 Outputs. Refer to <i>Tables 1, 2, and 3</i> for configuration.
Q2+, Q2-	6, 7	O	Differential Q2 Outputs. Refer to <i>Tables 1, 2, and 3</i> for configuration.
Q3+, Q3-	10, 9	O	Differential Q3 Outputs. Refer to <i>Tables 1, 2, and 3</i> for configuration.
Q4 +, Q4-	12, 13	O	Differential Q4 Outputs. Refer to <i>Tables 1, 2, and 3</i> for configuration.
Q5+, Q5-	25, 24	O	Differential Q5 Outputs. Refer to <i>Tables 1, 2, and 3</i> for configuration.
Q6+, Q6-	27, 28	O	Differential Q6 Outputs. Refer to <i>Tables 1, 2, and 3</i> for configuration.
Q7+, Q7-	31, 30	O	Differential Q7 Outputs. Refer to <i>Tables 1, 2, and 3</i> for configuration.
Q8+, Q8-	33, 34	O	Differential Q8 Outputs. Refer to <i>Tables 1, 2, and 3</i> for configuration.
Q9+, Q9-	37, 36	O	Differential Q9 Outputs. Refer to <i>Tables 1, 2, and 3</i> for configuration.
RANGE ¹	18	I	Frequency Range Selection Input. To determine the correct connection for this pin, refer to <i>Table 2</i> . This should be a static input
LOCK	43	O	PLL Locked Output. When this output is HIGH, the PLL in the CY23020-3 is in steady state operation mode (Locked). When this signal is LOW, the PLL is in the process of locking onto the reference signal.
S1:2	16, 15	I	Output/PLL Enable Selection Bits. Refer to <i>Table 1</i> .
VDDC	20, 21, 42	P	Analog Power Connection. Connect to 3.3V.
GNDC	19, 22, 41	G	Analog Ground Connection. Connect to common system ground plane.
VDD	5, 11, 26, 32, 38, 47	P	Output Buffer Power Connections. Connect 3.3V
GND	2, 8, 14, 23, 29, 35	G	Ground Connections. Connect to common system ground plane.
MUL ^[2]	17	I	Multiplication Factor Select. When set HIGH, the outputs will run at twice the speed of the reference signal. This should be a static input.
NC	44	NC	Do Not Connect. This pin must be left floating. This pin is used by the factory for testing purposes.

Table 1. Output Configuration

S1	S2	Outputs	PLL
0	0	Three-state	Shutdown
0	1	Reserved	
1	0	Reference Input	Shutdown
1	1	PLL Output	Enabled

Notes:

1. There are no power-up sequence requirements on the power supply pins of the CY23020-3.
2. RANGE and MUL have a ~100k pull-down.

Table 2. Frequency Range Setting

RANGE	Output Frequency Range
0	100–200 MHz
1	200–400 MHz

Table 3. Frequency Multiplication Table

MUL	Output Frequency
0	= REF
1	= 2 * REF

How to Implement Zero Delay

Typically, ZDBs multiply (fan-out) single-clock signals quantity while simultaneously reducing or mitigating the time delay associated with passing the clock through a buffering device. In many cases the output clock is adjusted, in phase, to occur later or more often before the device's input clock to compensate for a design's physical delay inadequacies. Most commonly this is done using a simple PCB trace as a time delay element. The longer the trace the earlier the output clock edges occur with respect to the reference input clock edges.

In this way such effects as undesired transit time of a clock signal across a PCB can be compensated for.

Inserting Other Devices in Feedback Path

Due to the fact that the device has an external feedback path the user has a wide range of control over its output to input skewing effect. One of these is to be able to synchronize the outputs of an external clock that is resultant from any of the output clocks. This implementation can be applied to any device (ASIC, multiple output clock buffer/driver, etc.) which is put into the feedback path.

Referring to *Figure 1*, if the traces between the ASIC/buffer and the destination of the clock signal(s) (A) are equal in length to the trace between the buffer and the FBIN pin (B), the signals at the destination(s) device (C) will be driven high at the same time the Reference clock provided to the ZDB goes high. Synchronizing the other outputs of the ZDB to the outputs from the ASIC/Buffer is more complex however, as any propagation delay in the ASIC/Buffer must be accounted for.

There are constraints when inserting other devices. If the devices contain PLLs or excessively long delay times they can easily cause the overall clocking system to become unstable as the components interact. For these designs it is advisable to contact Cypress for applications support.

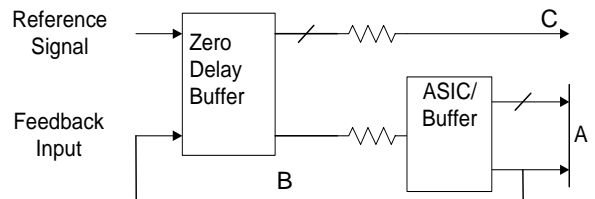

Figure 1. Output Buffer in Feedback Path

Table 4. Absolute Maximum Ratings^[3]

Parameter	Description	Rating	Unit
V _{DD}	Voltage on any V _{DD} pin with respect to GND	-0.5 to +5.0	V
V _{IN}	Voltage on any input pin with respect to GND	-0.5 to V _{DD} + 0.5	V
T _{STG}	Storage Temperature	-65 to +150	°C
T _A	Operation Temperature (QFN)	-40 to 85	°C
T _J	Junction Temperature	135	°C

Table 5. PECL DC Output Specification^[4]

Parameter	Description	Conditions	V _{CC} = 3.135		V _{CC} = 3.3		V _{CC} = 3.465	
			Min.	Max.	Min.	Max.	Min.	Max.
V _{OH}			1.835	2.435	2	2.6	2.165	2.765
V _{OL}			1.135	1.735	1.3	1.9	1.465	2.065
V _{OH} (rel to V _{CC})			-1.3	-0.7	-1.3	-0.7	-1.3	-0.7
V _{OL} (rel to V _{CC})			-2	-1.4	-2	-1.4	-2	-1.4
These result in the following mid point values: ^[4]								
V _{MID} ((V _{OH} + V _{OL})/2)			1.485	2.085	1.65	2.25	1.815	2.415
V _{MID} Relative to V _{CC}			-1.65	-1.05	-1.65	-1.05	-1.65	-1.05

Notes:

- Stresses greater than those listed in this table may cause permanent damage to the device. These represent a stress rating only. Operation of the device at these or any other conditions above those specified in the operating sections of this specification is not implied. Maximum conditions for extended periods may affect reliability.
- The midpoint voltage is average value of a waveform. For differential signals the midpoint is assumed to be the same for both the true and complement since the V_{OH} and V_{OL} of both the true and complement signals in general should be the same. V_{MID} is not necessarily equal to the differential crossover voltage, which may be skewed if there is differential time delays between the signals.

Table 5. PECL DC Output Specification (continued)^[4]

Parameter	Description	Conditions	V _{CC} = 3.135		V _{CC} = 3.3		V _{CC} = 3.465	
			Min.	Max.	Min.	Max.	Min.	Max.
			Min.		Max.		Unit	
I _{PD}	Power-down Current	70°C, V _{DD} max			100		μA	
I _{IL}		V _{IN} = 0			10		μA	
I _{IH}		V _{IN} = V _{DD}			100		μA	

Table 6. V_{DDC} = 3.3V ±5%, V_{DD} = 3.3V ±5% (See Test Set-ups, C_L = 5 pF)

Parameter	Description	Condition	Min.	Typ.	Max.	Unit
I _{DD}		Loaded, V _{DD} max, Cold, 400 MHz, all outputs switching			300	mA
C _{IN}	REF or FBIN ± Pin Capacitance		4	5	6	pF
C _L ^[5]	Load Cap			5		pF
V _{ISW}	Single Ended Input Swing		0.5		1.25	V
V _{IX} ^[6]	Input Crossover Voltage (expressed relative to V _{DD})		V _{DD} - 1.79		V _{DD} - 0.96	
S _I	Input Slew Rate	Measured from V _{IX MEAS} + 0.15 to V _{IX MEAS} - 0.15. (20–80% of a min input swing sig.)	0.9		4	V/ns
V _{OSW}	Single Ended Output Swing		0.6		1.1	V
V _{OX} ^[7]	Output Crossing Point	V _{O MID} = (V _{H MEAS} - V _{L MEAS})/2	V _{O MID} - 0.20		V _{O MID} - 0.20	
V _{OX} ^[8]	Output Crossing Point (relative to V _{DD})	V _{O MID} = (V _{H MEAS} - V _{L MEAS})/2	V _{DD} - 1.79		V _{DD} - 0.96	

Table 7. V_{DDC} = 3.3V ±5%, V_{DD} = 3.3V ±5% (See Test Set-ups, C_L = 5 pF)

Parameter	Description	Condition	Min.	Typ.	Max.	Unit
S _O	Output Rise/Fall Slew Rate	Measured from V _{IX MEAS} + 0.15 to V _{IX MEAS} - 0.15. (20–80% of a min input swing sig.)	0.9		2	V/ns
D _I	Input Duty Cycle	Input duty cycle	40		60	%
D _O	Output Duty Cycle	Differential crossing point	45		55	%
T _{PDIO}	REFin-FBin prop delay	External feedback REF, FB same frequency	-50		200	ps
T _{PDIOD}	REFin-FBin prop delay	External feedback REF, FB same frequency x2	-50		150	ps
T _{PDO}	FBout to any output prop delay		-325		-100	ps
T _{PDOB}		Output-Output skew within a bank			150	ps
T _{PDOB133}		Output-Output skew @133 MHz		75		ps
T _{TB}	Total Timing Budget				400	ps
T _{JCCPP}	Cycle-Cycle Jitter (1000 cycles) p-p	REF and outputs, same frequency			100	ps
T _{JCCRMS}	RMS Cycle-Cycle Jitter	REF and outputs, same frequency			15	ps
T _{JCCOP}		Ref = x2			125	ps
T _{Jrms}		Ref = x2			30	ps

Notes:

5. Same as input. PECL is assumed to drive single point loads.
6. This is the output DC mid-voltage range ± the crossover voltage tolerance. Refer Input Voltage is assumed to be derived from same supply as part. This is why it is spec'd relative to V_{DD}.
7. Crossover is within ± 20% of the center of the minimum swing.
8. Crossover is within ± 20% of the center of the minimum swing.

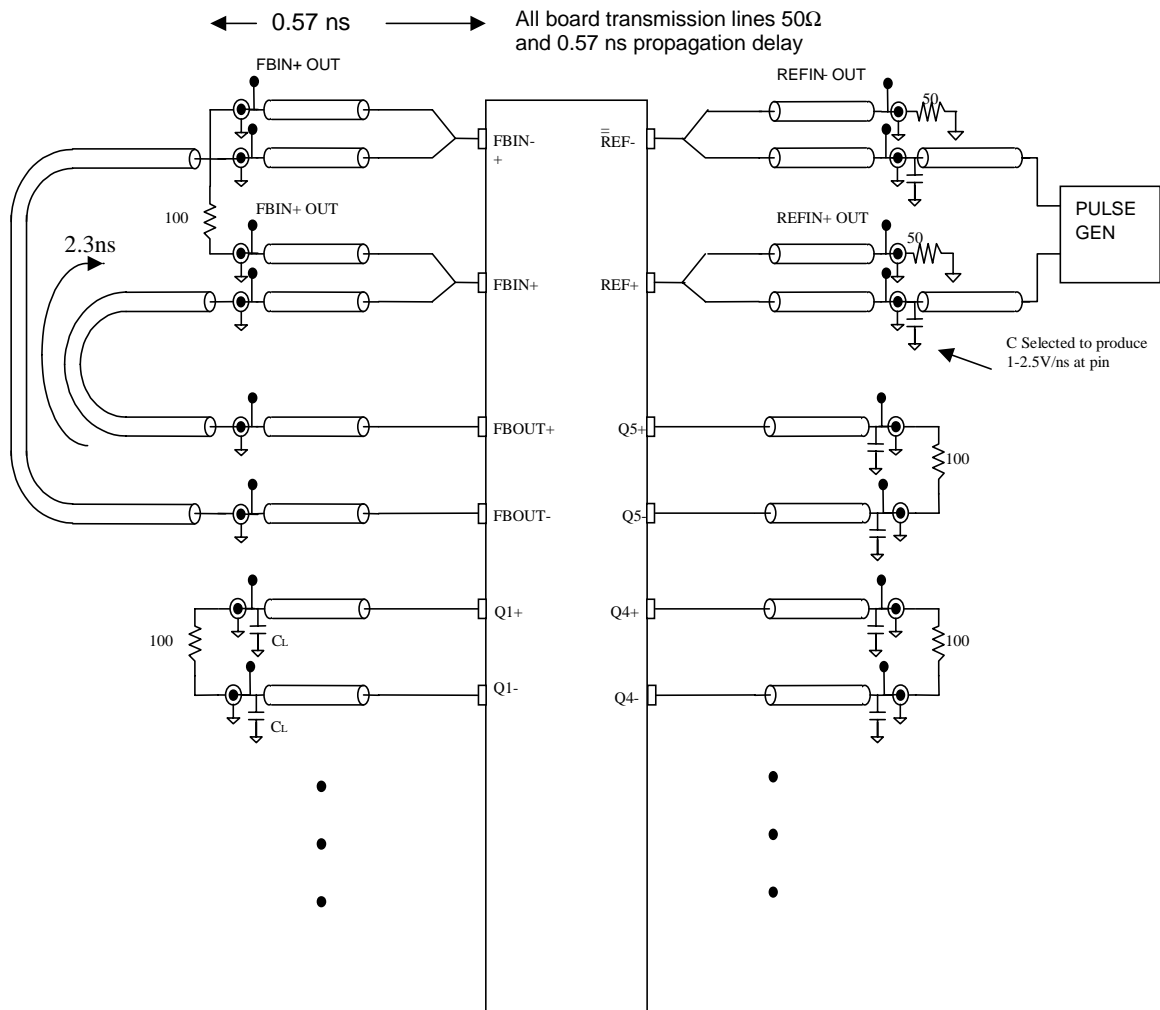

Figure 2. Test Set-up 1 Example

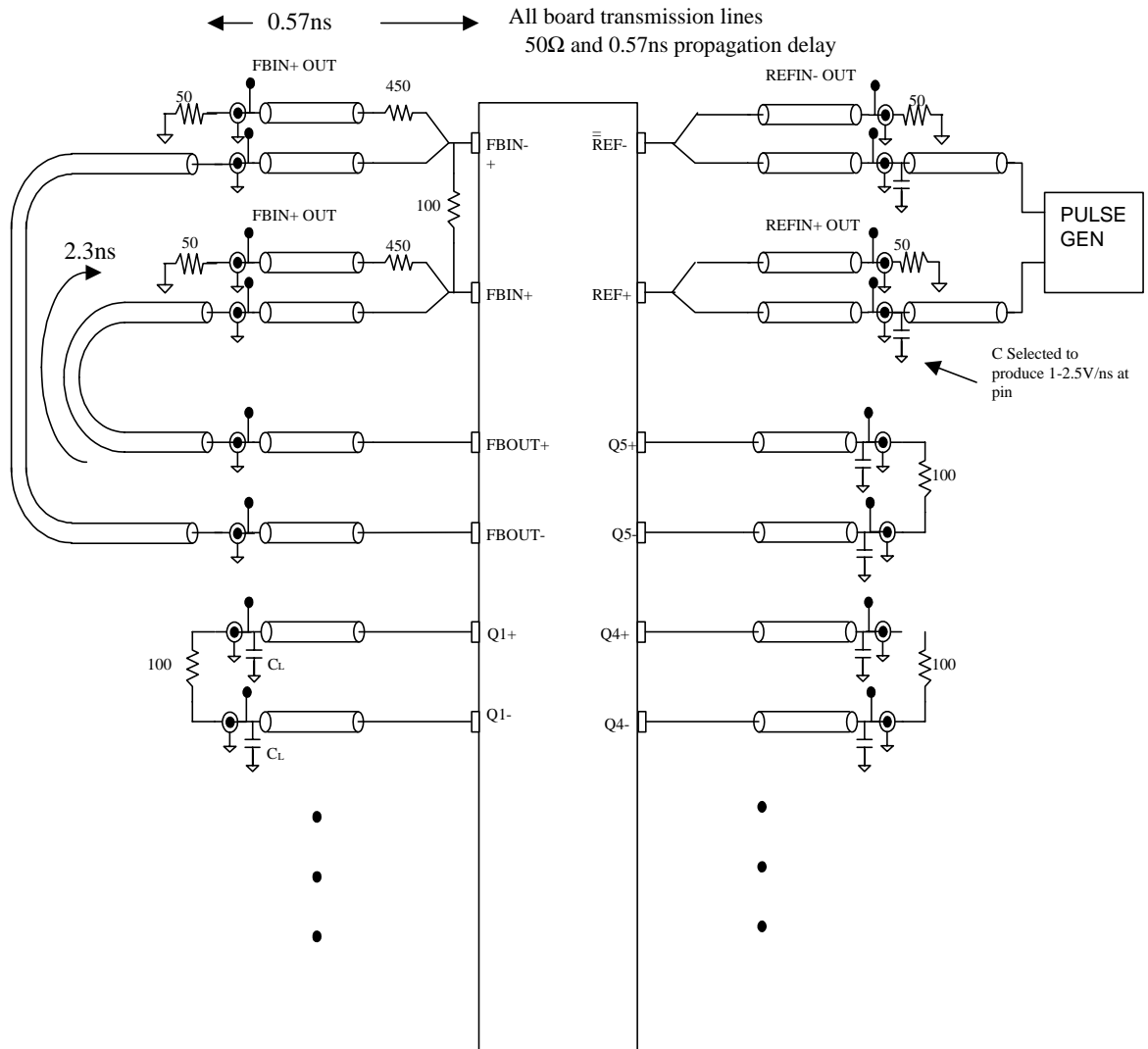

Figure 3. Test Set-up 2 Example^[9]

Note:

- 9. The above configuration may provide better termination at the FBIN input.

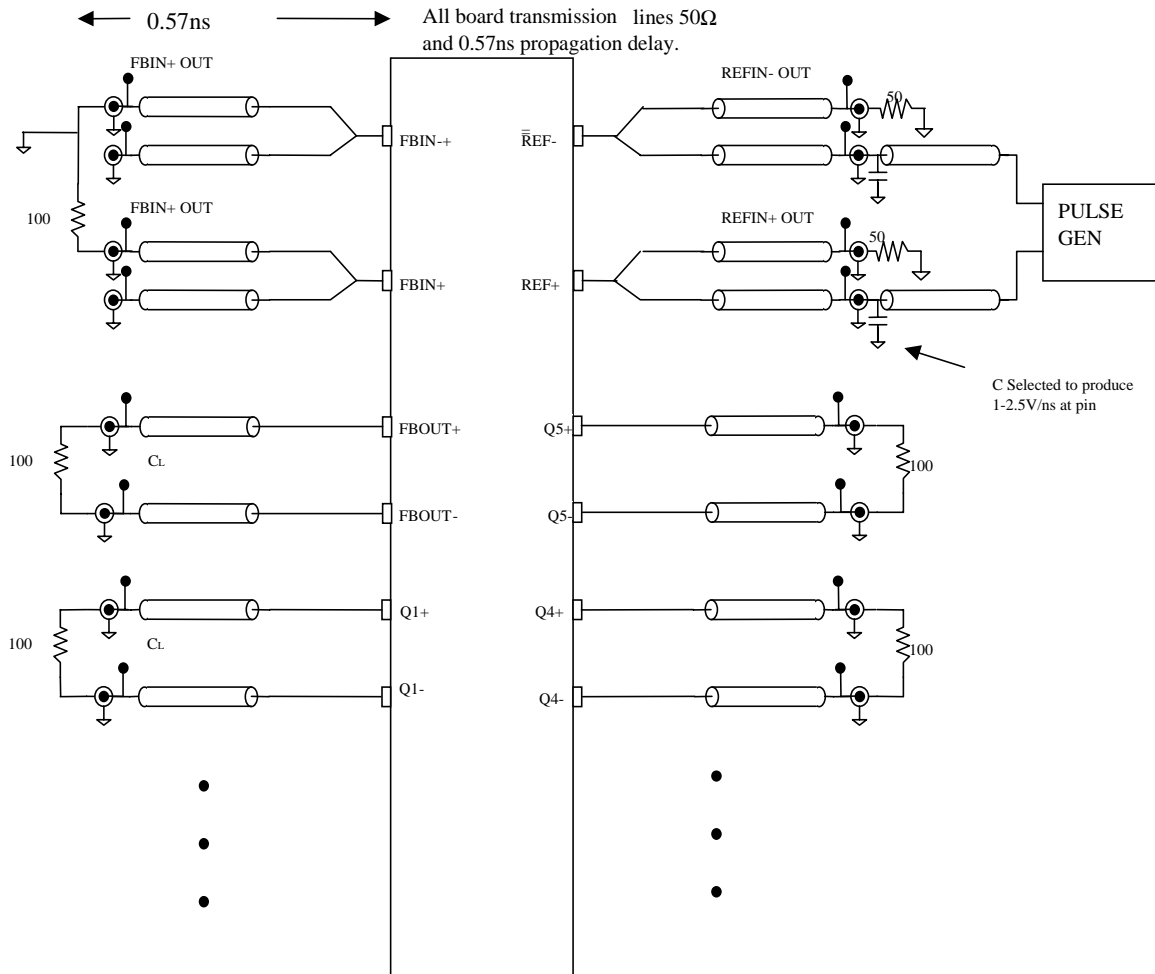

Figure 4. Test Set-up 3 Example^[10]

Ordering Information

Ordering Code	Package Type	Temperature Range
CY23020LFI-3	48-pin QFN	Industrial, -40°C to +85°C
CY23020LFI-3T	48-pin QFN-Tape and Reel	Industrial, -40°C to +85°C

Note:

10. If accurate pin-pin skew is not obtainable with the load capacitors, a third configuration can be made with no load C. In this case only pin-pin skew is characterized. Part must be in PLL bypass mode.

Package Drawing and Dimension

48-lead QFN (7 × 7 mm) LF48

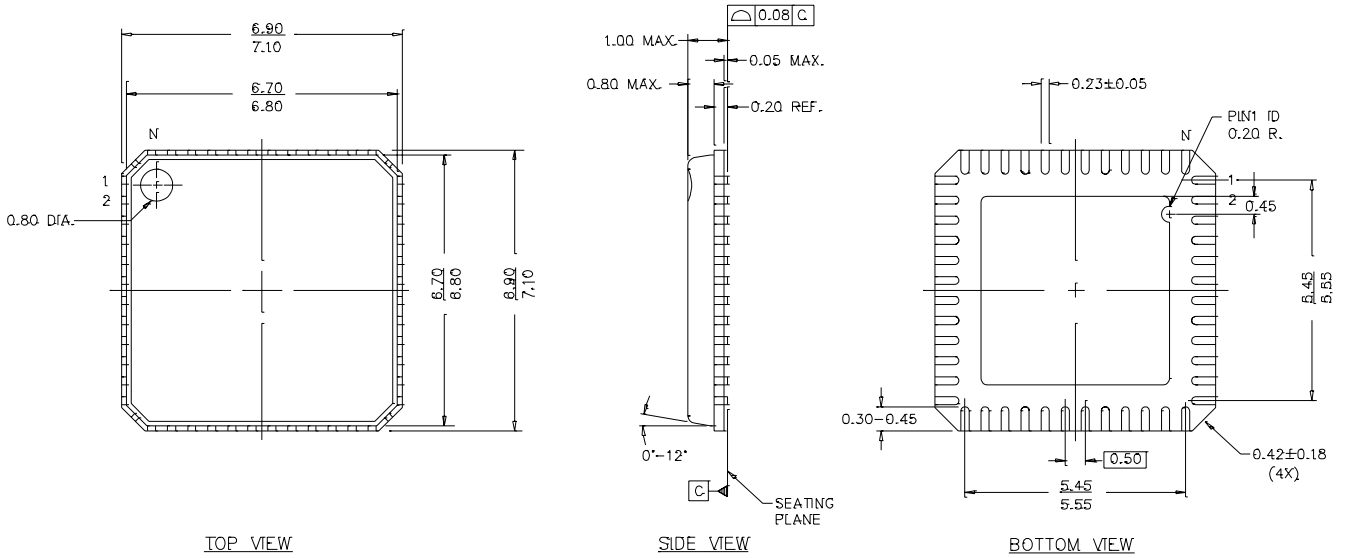

DIMENSIONS IN mm MIN. MAX.

51-85152-*A

Total Timing Budget and TTB are trademarks of Cypress Semiconductor. All product and company names listed in this document are the trademarks of their respective holders.



Document History Page

Document Title: CY23020-3 10-output, 400-MHz LVPECL Zero Delay Buffer Document Number: 38-07473				
REV.	ECN NO.	Issue Date	Orig. of Change	Description of Change
**	118965	11/05/02	HWT	New Data Sheet
*A	126939	06/10/03	RGL	Fixed the block diagram (removed the C1 input)