

Integrated Device Technology, Inc.

RISC CPU PROCESSOR RISCore™

IDT79R3500

FEATURES:

- Efficient Pipelining—The CPU's 5-stage pipeline design assists in obtaining an execution rate approaching one instruction per cycle. Pipeline stalls and exceptions are handled precisely and efficiently.
- On-Chip Cache Control—The IDT79R3500 provides a high-bandwidth memory interface that handles separate external Instruction and Data Caches ranging in size from 4 to 256KBs each. Both caches are accessed during a single CPU cycle. All cache control is on-chip.
- On-Chip Memory Management Unit—A fully-associative, 64-entry Translation Lookaside Buffer (TLB) provides fast address translation for virtual-to-physical memory mapping of the 4GB virtual address space.
- Dynamically able to switch between Big- and Little- Endian byte ordering conventions.
- Optimizing Compilers are available for C, FORTRAN, Pascal, COBOL, Ada, PL/1 and C++.
- 20 through 40MHz clock rates yield up to 32VUPS sustained throughput.
- Supports independent multi-word block refill of both the instruction and data caches with variable block sizes.
- Supports concurrent refill and execution of instructions.
- Partial word stores executed as read-modify-write.
- 6 external interrupt inputs, 2 software interrupts, with single cycle latency to exception handler routine.
- Flexible multiprocessing support on chip with no impact on uniprocessor designs.
- A single chip integrating the R3000 CPU and R3010 FPA execution units, using the R3000A pinout.
- Software compatible with R3000, R2000 CPUs and R3010, R2010 FPAs.
- TLB disable feature allowing a simple memory model for Embedded Applications.
- Programmable Tagbus width allowing reduced cost cache.
- Hardware Support of Single- and Double-Precision Floating Point Operations that include Add, Subtract, Multiply, Divide, Comparisons, and Conversions.
- Sustained Floating Point Performance of 11 MFlops single precision LINPACK and 7.3MFLOPS double precision
- Supports Full Conformance With IEEE 754-1985 Floating Point Specification
- 64-bit FP operation using sixteen 64-bit data registers
- Military product compliant to MIL-STD 883, class B

5

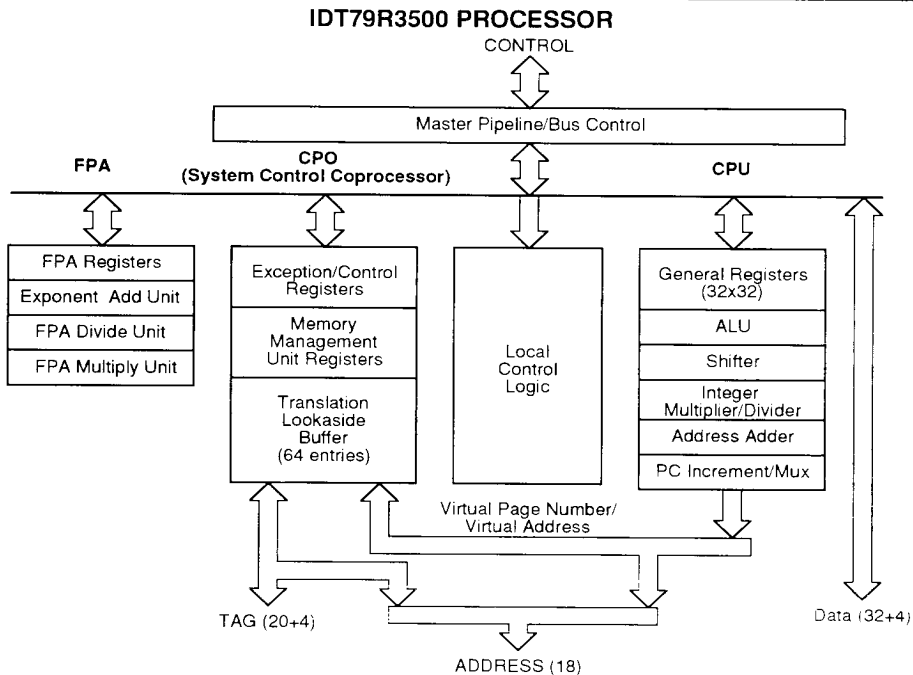

The IDT logo is a registered trademark and RISCore, CEMOS are trademarks of Integrated Device Technology, Inc.

2671 drw 01

MILITARY AND COMMERCIAL TEMPERATURE RANGES

OCTOBER 1992

© 1992 Integrated Device Technology, Inc.

5.3

DSC-90543

1

DESCRIPTION:

The IDT79R3500 RISC Microprocessor consists of three tightly-coupled processors integrated on a single chip. The first processor is a full 32-bit CPU based on RISC (Reduced Instruction Set Computer) principles to achieve a new standard of microprocessor performance. The second processor is a system control coprocessor, called CP0, containing a fully-associative 64-entry TLB (Translation Lookaside Buffer), MMU (Memory Management Unit) and control registers, supporting a 4GB virtual memory subsystem, and a Harvard Architecture Cache Controller achieving a bandwidth of 320MB/second using industry standard static RAMs. The third processor is the Floating Point Accelerator which performs arithmetic operations on values in floating-point representations. This processor fully conforms to the requirements of ANSI/IEEE Standard 754-1985, "IEEE Standard for Binary Floating-Point Arithmetic." In addition, the architecture fully supports the standard's recommendations.

The programmer model of this device will be the same as the programmer model of a system which uses a discrete IDT79R3000 with the IDT79R3010: 32 integer registers, 16 floating point registers; co-processor 0 registers; floating point status and control register; RISC integer ALU; Integer Multiply and Divide ALU; Floating Point Add/Subtract, Multiply, and Divide ALUs. The device pipeline will be the same as for the IDT79R3000, as will the co-processor 0 functionality. No new instructions have been introduced. Pin compatibility extends to AC and DC characteristics, software execution and initialization mode vector selection.

This data sheet provides an overview of the features and architecture of the IDT79R3500 CPU, Revision 3.0. A more detailed description of the operation of the device is incorporated in the *R3500 Family Hardware User Manual*, and a more detailed architectural overview is provided in the *MIPS RISC Architecture* book, both available from IDT. Documentation providing details of the software and development environments supporting this processor are also available from IDT.

IDT79R3500 CPU Registers

The IDT79R3500 CPU provides 32 general purpose 32-bit registers, a 32-bit Program Counter, and two 32-bit registers that hold the results of integer multiply and divide operations. Only two of the 32 general registers have a special purpose: register r0 is hardwired to the value "0", which is a useful constant, and register r31 is used as the link register in jump-and-link instructions (return address for subroutine calls).

The CPU registers are shown in Figure 2. Note that there is no Program Status Word (PSW) register shown in this figure: the functions traditionally provided by a PSW register are instead provided in the Status and Cause registers incorporated within the System Control Coprocessor (CP0).

FPA REGISTERS

The IDT79R3010A FPA provides 32 general purpose 32-bit registers, a Control/Status register, and a Revision Identification register.

Floating-point coprocessor operations reference three types of registers:

- Floating-Point Control Registers (FCR)
- Floating-Point General Registers (FGR)
- Floating-Point Registers (FPR)

General Purpose Registers

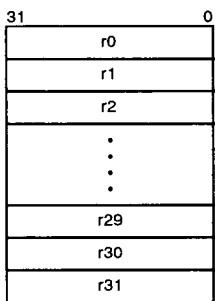

Multiply/Divide Registers

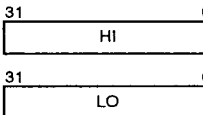

Program Counter

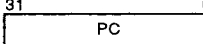

Figure 2. IDT79R3500 CPU Registers

2871 drw 02

Floating-Point General Registers (FGR)

There are 32 Floating-Point General Registers (FGR) on the FPA. They represent directly-addressable 32-bit registers, and can be accessed by Load, Store, or Move Operations.

Floating-Point Registers (FPR)

The 32 FGRs described in the preceding paragraph are also used to form sixteen 64-bit Floating-Point Registers (FPR). Pairs of general registers (FGRs), for example FGR0 and FGR1 (Figure 3) are physically combined to form a single 64-bit FPR. The FPRs hold a value in either single- or double-precision floating-point format. Double-precision format FPRs are formed from two adjacent FGRs.

Floating-Point Control Registers (FCR)

There are 2 Floating-Point Control Registers (FCR) on the FPA. They can be accessed only by Move operations and include the following:

- Control/Status register, used to control and monitor exceptions, operating modes, and rounding modes;
- Revision register, containing revision information about the FPA.

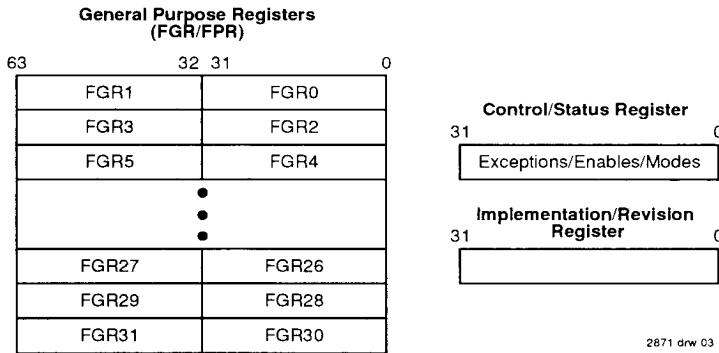

Figure 3. FPA Registers

Instruction Set Overview

All IDT79R3500 instructions are 32 bits long, and there are only three instruction formats. This approach simplifies instruction decoding, thus minimizing instruction execution time. The IDT79R3500 processor initiates a new instruction on every run cycle, and is able to complete an instruction on almost every clock cycle. The only exceptions are the Load instructions and Branch instructions, which each have a single cycle of latency associated with their execution. Note, however, that in the majority of cases the compilers are able to fill these latency cycles with useful instructions which do not require the result of the previous instruction. This effectively eliminates these latency effects.

The actual instruction set of the CPU was determined after extensive simulations to determine which instructions should be implemented in hardware, and which operations are best synthesized in software from other basic instructions. This methodology resulted in the IDT79R3500 having the highest performance of any available microprocessor.

I-Type (Immediate)

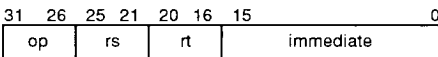

J-Type (Jump)

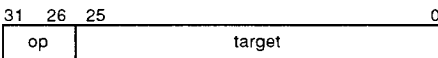

R-Type (Register)

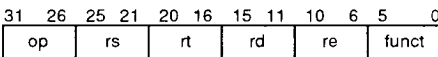

2871 drw 04

Figure 4. IDT79R3500 Instruction Formats

The IDT79R3500 instruction set can be divided into the following groups:

- **Load/Store** instructions move data between memory and general registers. They are all I-type instructions, since the only addressing mode supported is base register plus 16-bit, signed immediate offset. The Load instruction has a single cycle of latency, which means that the data being loaded is not available to the instruction immediately after the load instruction. The compiler will fill this delay slot with either an instruction which is not dependent on the loaded data, or with a NOP instruction. There is no latency associated with the store instruction. Loads and Stores can be performed on byte, half-word, word, or unaligned word data (32-bit data not aligned on a modulo-4 address). The CPU cache is constructed as a write-through cache.
- **Computational** instructions perform arithmetic, logical and shift operations on values in registers. They occur in both R-type (both operands and the result are registers) and I-type (one operand is a 16-bit immediate) formats. FP computational instructions perform arithmetic operations on floating point values in the FPA registers. Note that computational instructions are three operand instructions; that is, the result of the operation can be stored into a different register than either of the two operands. This means that operands need not be overwritten by arithmetic operations. This results in a more efficient use of the large register set.
- **Conversion** instructions perform conversion operations on the floating point values in the FPA registers.
- **Compare** instructions perform comparisons of the contents of FPA registers and set a condition bit based on the results. The result of the compare operations is tied directly to Cp Cond (1) for software testing.
- **Jump and Branch** instructions change the control flow of a program. Jumps are always to a paged absolute address formed by combining a 26-bit target with four bits of the Program counter (J-type format, for subroutine calls), or 32-bit register byte addresses (R-type, for returns and



OP	Description	OP	Description
	Load/Store Instructions		Shift Instructions (Cont.)
LB	Load Byte	SRA	Shift Right Arithmetic
LBU	Load Byte Unsigned	LLV	Shift Left Logical Variable
LH	Load Halfword	SRLV	Shift Right Logical Variable
LHU	Load Halfword Unsigned	SRAV	Shift Right Arithmetic Variable
LW	Load Word		FPA Conversion Instructions
LWL	Load Word Left	CVT.S.fmt	Floating point Convert to Single FP
LWR	Load Word Right	CVT.D.fmt	Floating point Convert to Double FP
SB	Store Byte	CVT.W.fmt	Floating point Convert to fixed point
SH	Store Halfword		Multiply/Divide Instructions
SW	Store Word	MULT	Multiply
SWL	Store Word Left	MULTU	Multiply Unsigned
SWR	Store Word Right	DIV	Divide
	FPA Load/Store/Move Instructions	DIVU	Divide Unsigned
LWC1	Load Word to FPA	MFHI	Move From HI
SWC1	Store Word from FPA	MTHI	Move To HI
MTC1	Move Word to FPA	MFLO	Move From LO
MFC1	Move Word from FPA	MTLO	Move To LO
CTC1	Move Control word to FPA		Jump and Branch Instructions
CFC1	Move Control word from FPA	J	Jump
	Arithmetic Instructions (ALU Immediate)	JAL	Jump and Link
ADDI	Add Immediate	JR	Jump to Register
ADDIU	Add Immediate Unsigned	JALR	Jump and Link Register
SLTI	Set on Less Than Immediate	BEQ	Branch on Equal
SLTIU	Set on Less Than Immediate Unsigned	BNE	Branch on Not Equal
ANDI	AND Immediate	BLEZ	Branch on Less than or Equal to Zero
ORI	OR Immediate	BGTZ	Branch on Greater Than Zero
XORI	Exclusive OR Immediate	BLTZ	Branch on Less Than Zero
LUI	Load Upper Immediate	BGEZ	Branch on Greater than or Equal to Zero
	Arithmetic Instructions (3-operand, register-type)	BLTZAL	Branch on Less Than Zero and Link
ADD	Add	BGEZAL	Branch on Greater than or Equal to Zero and Link
ADDU	Add Unsigned		Special Instructions
SUB	Subtract	SYSCALL	System Call
SUBU	Subtract Unsigned	BREAK	Break
SLT	Set on Less Than		Coprocessor Instructions
SLTU	Set on Less Than Unsigned	LWCZ	Load Word from Coprocessor
AND	AND	SWCZ	Store Word to Coprocessor
OR	OR	MTCZ	Move To Coprocessor
XOR	Exclusive OR	MFCZ	Move From Coprocessor
NOR	NOR	CTCZ	Move Control to Coprocessor
	FPA Computational Instructions	CFCZ	Move Control From Coprocessor
ADD.fmt	Floating point Add	COPZ	Coprocessor Operation
SUB.fmt	Floating point Subtract	BCZT	Branch on Coprocessor z True
MUL.fmt	Floating point Multiply	BCZF	Branch on Coprocessor z False
DIV.fmt	Floating point Divide		System Control Coprocessor (CPO) Instructions
ABS.fmt	Floating-point Absolute value	MTC0	Move To CPO
MOV.fmt	Floating point Move	MFC0	Move From CPO
NEG.fmt	Floating point Negate	TLBR	Read indexed TLB entry
	FPA Compare Instructions	TLBWI	Write Indexed TLB entry
C.cond.fmt	Floating-point Compare	TLBWR	Write Random TLB entry
	Shift Instructions	TLBP	Probe TLB for matching entry
SLL	Shift Left Logical	RFE	Restore From Exception
SRL	Shift Right Logical		

dispatches). Branches have 16-bit offsets relative to the program counter (I-type). Jump and Link instructions save a return address in Register 31. The R3500 instruction set features a number of branch conditions. Included is the ability to compare a register to zero and branch, and also the ability to branch based on a comparison between two registers. Thus, net performance is increased since software does not have to perform arithmetic instructions prior to the branch to set up the branch conditions.

- **Coprocessor** instructions perform operations in the coprocessors. Coprocessor Loads and Stores are I-type.
- **Coprocessor 0** instructions perform operations on the System Control Coprocessor (CP0) registers to manipulate the memory management and exception handling facilities of the processor.
- **Special** instructions perform a variety of tasks, including movement of data between special and general registers, system calls, and breakpoint. They are always R-type.

Table 1 lists the instruction set of the IDT79R3500 processor.

SYSTEM CONTROL COPROCESSOR (CP0) INSTRUCTIONS

Register	Description
EntryHi	High half of a TLB entry
EntryLo	Low half of a TLB entry
Index	Programmable pointer into TLB array
Random	Pseudo-random pointer into TLB array
Status	Mode, interrupt enables, and diagnostic status info
Cause	Indicates nature of last exception
EPC	Exception Program Counter
Context	Pointer into kernel's virtual Page Table Entry array
BadVA	Most recent bad virtual address
PRId	Processor revision identification (Read only)

2871 tbi 02

IDT79R3500 System Control Coprocessor (CP0)

The IDT79R3500 can operate with up to four tightly-coupled coprocessors (designated CP0 through CP3). The System Control Coprocessor (or CP0), is incorporated on the IDT79R3500 chip and supports the virtual memory system and exception handling functions of the IDT79R3500. The virtual memory system is implemented using a Translation Lookaside Buffer and a group of programmable registers as shown in Figure 5.

System Control Coprocessor (CP0) Registers

The CP0 registers shown in Figure 5 are used to control the memory management and exception handling capabilities of the IDT79R3500. Table 2 provides a brief description of each register.

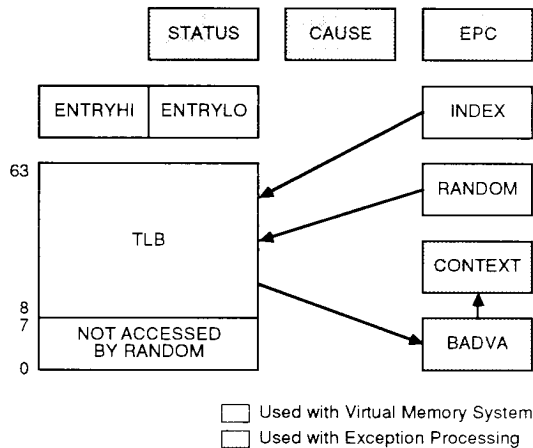

2871 drw 05

Figure 5. The System Coprocessor Registers

5

Memory Management System

The IDT79R3500 has an addressing range of 4GB. However, since most IDT79R3500 systems implement a physical memory smaller than 4GBs, the IDT79R3500 provides for the logical expansion of memory space by translating addresses composed in a large virtual address space into available physical memory address. Two TLB modes are supported. When the TLB is used, the 4GB address space is divided into 2GBs which can be accessed by both the users and the kernel, and 2GBs for the kernel only. Virtual addresses within the kernel/user segment are translated to physical addresses on a 4kB page basis. This mode is typical of UNIX and other sophisticated operating systems. When the TLB is disabled, mapping is locked as 2GBs as kernel/user, and 1.5GBs as kernel only. This mode requires no TLB manipulation, provides large linear address space, and is typical for embedded applications.

TLB (Translation Lookaside Buffer)

Virtual memory mapping is assisted by the Translation Lookaside Buffer (TLB). The on-chip TLB provides very fast virtual memory access and is well-matched to the requirements of multi-tasking operating systems. The fully-associative TLB contains 64 entries, each of which maps a 4kB page, with controls for read/write access, cacheability, and process identification. The TLB allows each user to access up to 2GBs of virtual address space.

Figure 6 illustrates the format of each TLB entry. The Translation operation involves matching the current Process

ID (PID) and upper 20 bits of the address against PID and VPN (Virtual Page Number) fields in the TLB. When both match (or the TLB entry is Global), the VPN is replaced with the PFN (Physical Frame Number) to form the physical address.

TLB misses are handled in software, with the entry to be replaced determined by as imple RANDOM function. The routine to process a TLB miss in the UNIX environment requires only 10-12 cycles, which compares favorably with many CPUs which perform the operation in hardware.

TLB Disabled Operation

Many embedded systems do not like the complexity or uncertainty associated with the on-chip TLB. However, many systems still desire the ability to implement a kernel/user mode. Therefore, to implement a hierachical task model, the TLB must be used. The R3500 gives the system designer one more option, allowing the TLB to be disabled and performing a fixed mapping of virtual to physical addresses, while maintaining separation of kernel and user resources.

The user may elect to disable the TLB through the reset sectors. In this case, the mapping shown in Figure 8. is used, and device power consumption is reduced. Note tha "cached" segments means that there is no mechanism to exclude addresses in these regions from the cache.

This mapping means that applications designed to run in kseg0 and kseg1 (to avoid the TLB) can use the R3500, disable the TLB to reduce power, and not have to change software to take advantage of this new feature.

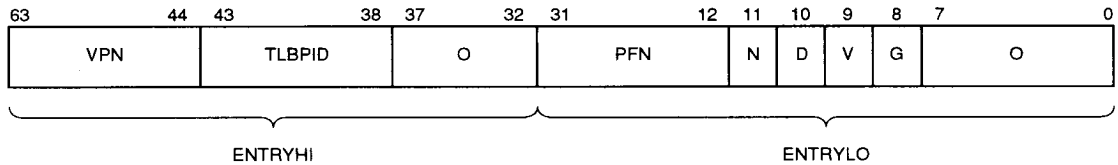

- VPN – Virtual Page Number
- TLBPID – Process ID
- PFN – Physical Frame Number
- N – Non-cacheable flag
- D – Dirty flag (Write protect)
- V – Valid entry flag
- G – Global flag (ignore PID)
- O – Reserved

Figure 6. TLB Entry Format

2871 drw 06

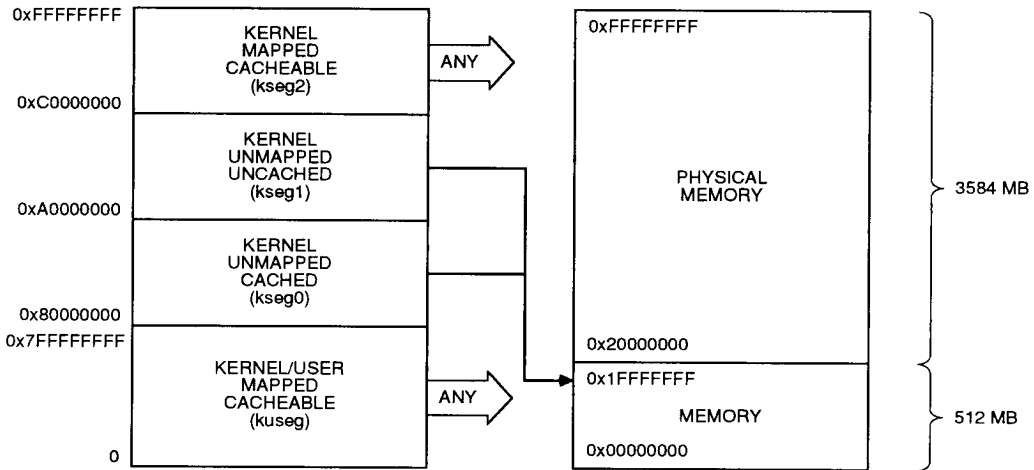
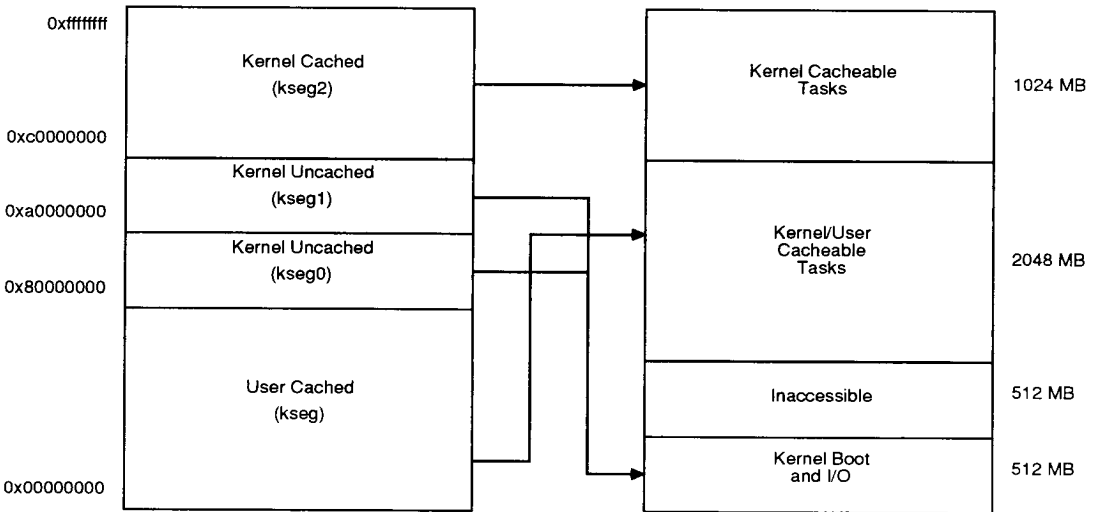

Figure 7. IDT79R3500 Virtual Address Mapping

2871 drw 07

MNU Address Translation
Virtual → Physical
(TBL Disabled)

5



2871 drw 08

NOTE: This model is consistent with the mapping available in the IDT79R3051 family. The identical mapping provides software compatibility to the lower cost CPUs.

Figure 8. TLB Disabled Mapping

Operating Modes

The IDT79R3500 has two operating modes: User mode and Kernel mode. The IDT79R3500 normally operates in the User mode until an exception is detected forcing it into the Kernel mode. It remains in the Kernel mode until a Restore From Exception (RFE) instruction is executed. The manner in which memory addresses are translated or mapped depends on the operating mode of the IDT79R3500. Figure 7 shows the MMU translation performed for each of the operating modes.

User Mode—in this mode, a single, uniform virtual address space (kuseg) of 2GB is available. When the TLB is used, each virtual address is extended with a 6-bit process identifier field to form unique virtual addresses. All references to this segment are mapped through the TLB. Use of the cache for up to 64 processes is determined by bit settings for each page within the TLB entries. If the TLB is not used, these addresses are translated to begin at 1 GB of the physical address space.

Kernel Mode—four separate segments are defined in this mode:

- *kuseg*—when in the kernel mode, references to this segment are treated just like user mode references, thus streamlining kernel access to user data.
- *kseg0*—references to this 512MB segment use cache memory but are not mapped through the TLB. Instead, they always map to the first 0.5GB of physical address space.
- *kseg1*—references to this 512MB segment are not mapped through the TLB and do not use the cache. Instead, they are hard-mapped into the same 0.5GB segment of physical address space as *kseg0*.
- *kseg2*—when the TLB is not used, references to this 1GB segment directly addresses the upper 1GB of physical address space. These addresses are defined to be kernel mode which are cacheable. When the TLB is used, references to this 1GB segment are always mapped through the TLB and use of the cache is determined by bit settings within the TLB entry.

FPA COPROCESSOR OPERATION (CP1)

The FPA continually monitors the processor instruction stream. If an instruction does not apply to the coprocessor, it is ignored; if an instruction does apply to the coprocessor, the FPA executes that instruction and transfers necessary result and exception data synchronously to the main processor.

The FPA performs three types of operations:

- Loads and Stores;
- Moves;
- Two- and three-register floating-point operations.

Load, Store, and Move Operation

Load, Store, and Move operations data between memory or the integer registers and the FPA registers. These operations perform no format conversions and cause no floating-point exceptions. Load, Store, and Move operations reference a single 32-bit word of either the Floating-Point General Registers (FGR) or the Floating-Point Control Registers (FCR).

Floating-Point Operations

The FPA supports the following single- and double-precision format floating-point operations:

- Add
- Subtract
- Multiply
- Divide
- Absolute Value
- Move
- Negate
- Compare

In addition, the FPA supports conversions between single- and double-precision floating-point formats and fixed-point formats.

The FPA incorporates separate Add/Subtract, Multiply, and Divide units, each capable of independent and concurrent operation. Thus, to achieve very high performance, floating point divides can be overlapped with floating point multiplies and floating point additions. These floating point operations occur independently of the actions of the CPU, allowing further overlap of integer and floating point operations. Figure 9 illustrates an example of the types of overlap permissible.

Exceptions

The FPA supports all five IEEE standard exceptions:

- Invalid Operation
- Inexact Operation
- Division by Zero
- Overflow
- Underflow

The FPA also supports the optional, Unimplemented Operation exception that allows unimplemented instructions to trap to software emulation routines.

The FPA provides precise exception capability to the CPU; that is, the execution of a floating point operation which generates an exception causes that exception to occur at the CPU instruction which caused the operation. This precise exception capability is a requirement in applications and languages which provide a mechanism for local software exception handlers within software modules.

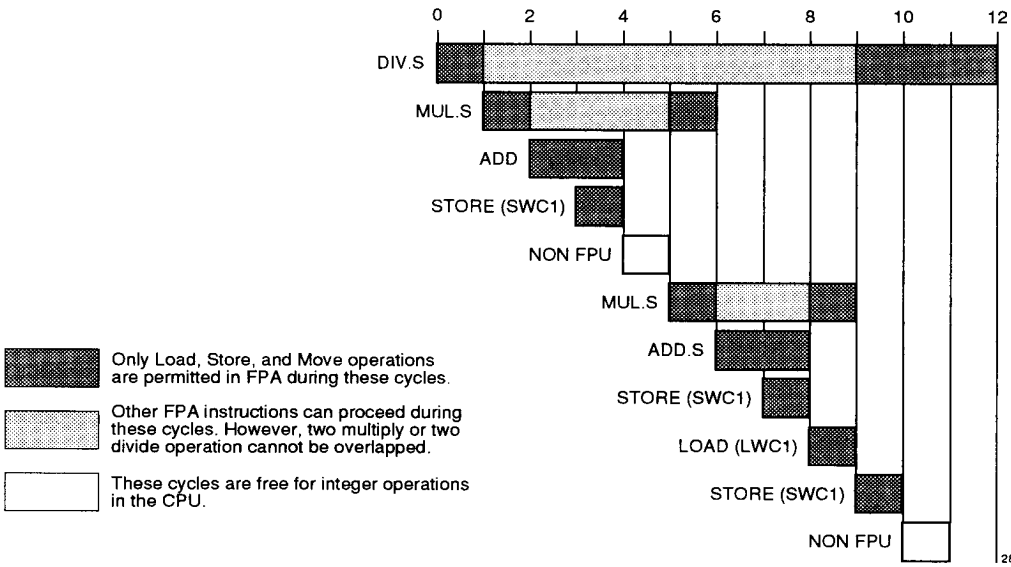

Figure 9. Examples of Overlapping Floating Point Operation

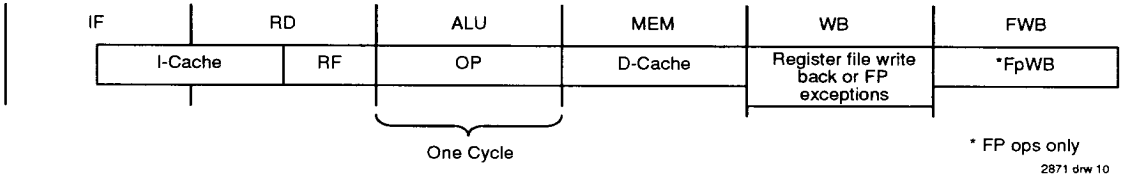

Figure 10. Instruction Execution

5

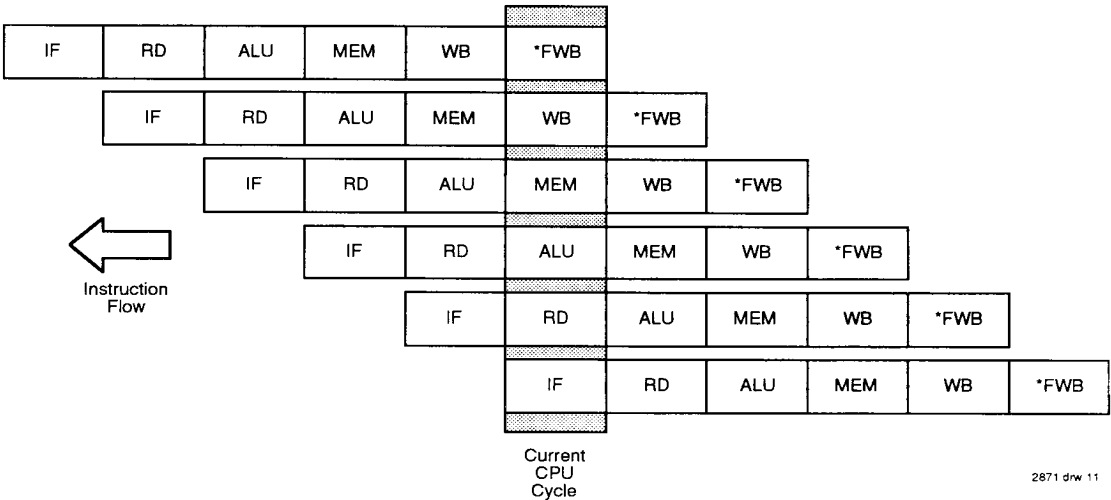

Figure 11. IDT79R3500 Execution Sequence

IDT79R3500 PIPELINE ARCHITECTURE

The execution of a single IDT79R3500 integer instruction consists of five pipe stages while floating point instruction takes six pipe stages. They are:

- 1) IF—Instruction fetch. The processor calculates the instruction address required to read from the I cache.
- 2) RD—The instruction is present on the data bus during phase one of this pipe stage. Instruction decode occurs during phase two. Operands are read from the registers if required.
- 3) ALU—Perform the required operation on instruction operands. If this is a FPA instruction, instruction execution commences.
- 4) MEM—Access memory. If the instruction is a load or store, the data is presented or captured during phase 2 of this pipe stage.
- 5) WB—Write integer results back into register file. In FPA cycles this pipe stage is used for exceptions.
- 6) FWB—The FPA uses this stage to write back ALU results to its register file.

Each of these steps requires approximately one FPA cycle as shown in Figure 10. (parts of some operations spill over into another cycle while other operations require only 1/2 cycle.)

The CPU uses a five stage pipeline while while the FPA uses a 6 stage to achieve an instruction execution rate approaching one instruction per cycle. Thus, execution of six instructions at a time are overlapped as shown in Figure 11.

This pipeline operates efficiently because different CPU resources (address and data bus accesses, ALU operations, register accesses, and so on) are utilized on a non-interfering basis.

MEMORY SYSTEM HIERARCHY

The high performance capabilities of the IDT79R3500 processor demand system configurations incorporating techniques frequently employed in large, mainframe computers but seldom encountered in systems based on more traditional microprocessors.

A primary goal of systems employing RISC techniques is to minimize the average number of cycles each instruction requires for execution. Techniques to reduce cycles-per-instruction include a compact and uniform instruction set, a deep instruction pipeline (as described above), and utilization of optimizing compilers. Many of the advantages obtained from these techniques can, however, be negated by an inefficient memory system.

Figure 12 illustrates memory in a simple microprocessor system. In this system, the CPU outputs addresses to memory and reads instructions and data from memory or writes data to memory. The address space is completely undifferentiated: instructions, data, and I/O devices are all treated the same. In such a system, a primary limiting performance factor is memory bandwidth.

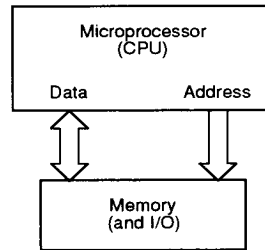

2871 drw 12

Figure 12. A Simple Microprocessor Memory System

Figure 13 illustrates a memory system that supports the significantly greater memory bandwidth required to take full advantage of the IDT79R3500's performance capabilities. The key features of this system are:

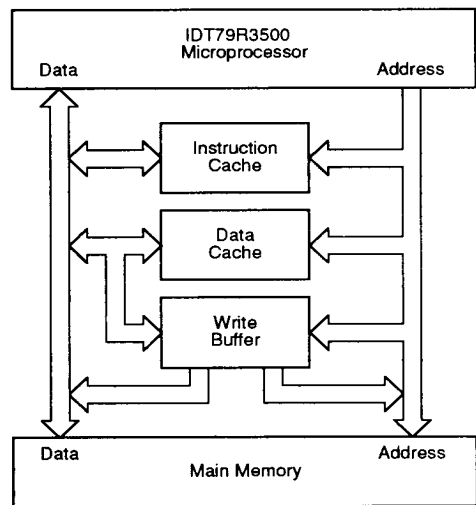

2871 drw 13

Figure 13. An IDT79R3500 System with a High-Performance Memory System

- **External Cache Memory**—Local, high-speed memory (called cache memory) is used to hold instructions and data that is repetitively accessed by the CPU (for example, within a program loop) and thus reduces the number of references that must be made to the slower-speed main memory. Some microprocessors provide a limited amount of cache memory on the CPU chip itself. The external caches supported by the IDT79R3500 can be much larger; while a small cache can improve performance of some programs, significant improvements for a wide range of programs require large caches.
- **Separate Caches for data and Instructions**—Even with high-speed caches, memory speed can still be a limiting factor because of the fast cycle time of a high-performance microprocessor. The IDT79R3500 supports separate caches for instructions and data and alternates accesses of the two caches during each CPU cycle. Thus, the processor can obtain data and instructions at the cycle rate of the CPU using caches constructed with commercially available IDT static RAM devices.
In order to maximize bandwidth in the cache while minimizing the requirement for SRAM access speed, the IDT79R3500 divides a single-processor clock cycle into two phases. During one phase, the address for the data cache access is presented while data previously addressed in the instruction cache is read; during the next phase, the data operation is completed while the instruction cache is being addressed. Thus, both caches are read in a single processor cycle using only one set of address and data pins.
- **Write Buffer**—in order to ensure data consistency, all data that is written to the data cache must also be written out to main memory. The cache write model used by the IDT79R3500 is that of a write-through cache; that is, all data written by the CPU is immediately written into the main memory. To relieve the CPU of this responsibility (and the inherent performance burden) the IDT79R3500 supports an interface to a write buffer. The IDT79R3020 Write Buffer captures data (and associated addresses) output by the CPU and ensures that the data is passed on to main memory.

IDT79R3500 Processor Subsystem Interfaces

Figure 14 illustrates the three subsystem interfaces provided by the IDT79R3500 processor:

- **Cache control** interface (on-chip) for separate data and instruction caches permits implementation of off-chip caches using standard IDT SRAM devices. The IDT79R3500 directly controls the cache memory with a minimum of external components. Both the instruction and data cache can vary from 0 to 256kB (64K entries). The IDT79R3500 also includes the TAG control logic which determines whether or not the entry read from the cache is the desired data. The IDT79R3500 implements an advanced feature that allows certain tag comparisons to

be eliminated, which in turn reduces the number of cache SRAMs required. The Int(5) reset mode vector contains two bits which sets the tag comparison options. Table 3 illustrates the tag disable encoding. The first row in the table implements the standard IDT79R3000A operating mode where all the tag and tag parity are used. The second row eliminates the upper 4 tag bits, eliminating normally required SRAMs and limiting main memory addressing to 128mB. The third row eliminates the lower 4 tag bits, which requires the cache to be at least 64kB each. The fourth row eliminates the upper 4 and lower 4 tag bits, requiring at least 16K cache entries, and limits main memory addressing to 128mB. In all cases, the IDT79R3500 continues to check tag parity which are selected as driven from the cache. The IDT79R3500 cache controller implements a direct mapped cache for high net performance (bandwidth). It has the ability to refill multiple words when a cache miss occurs, thus reducing the effective miss rate to less than 2% for large caches. When a cache miss occurs, the IDT79R3500 can support refilling the cache in 1, 4, 8, 16, or 32 word blocks to minimize the effective penalty of having to access main memory. The IDT79R3500 also incorporates the ability to perform instruction streaming; while the cache is refilling, the processor can resume execution once the missed word is obtained from main memory. In this way, the processor can continue to execute concurrently with the cache block refill.

- **Memory controller** interface for system (main) memory. This interface also includes the logic and signals to allow operation with a write buffer to further improve memory bandwidth. In addition to the standard full word access, the memory controller supports the ability to write bytes and half-words by using partial word operations. The memory controller also supports the ability to retry memory accesses if, for example, the data returned from memory is invalid and a bus error needs to be signalled.
- **Coprocessor Interface**—The IDT79R3500 features a set of on board tightly coupled coprocessors. Coprocessor 0 is defined to be the system control coprocessor and Coprocessor 1 is the Floating Point Accelerator. They have direct access to the internal data bus which allows them direct load and store of data in the same fashion as accessing the CPU registers. This relieves the typical bottleneck of having to load data into the CPU register set and then passing that data off to the co-processors.
In applications where the FPA was off chip, as in using the IDT79R3010A, several control pins were used for communications with the CPU and a Phase Lock Loop was located on the IDT79R3010A to synchronize the two together. As they are now integrated into a single chip, these are no longer needed. The FpCond output, which is used in coprocessor branch instructions, is now internally tied to the CpCond(1) input of the CPU leaving the external CpCond(1) pin available for another function. This signal is selectable to either output the FpBusy or the FpInt. Cp

5

Cond(1) output selection is determined at reset time according to the value read on Int(4). Table 4 illustrates the options that allow the FpInt to be routed to either the CpCond(1) output, or one of the internal Int pins. If it is internally routed, that interrupt is dedicated and that input will no longer affect the IDT79R3500. The selection of using CpCond(1) allows some external Logic to be added to the path, which might be required in some applications. Another method for Fpint handling is also accommodated. A mode pin, previously VCC can be programmed to route the FPU interrupt to a dedicated Fpint output that was

previously a GND. If the mode pin is sampled at reset as a 0, the dedicated Fpint indicates the FPU interrupt - if a 1, then the routing of Table 4 applies.

The internal CPBusy input, which is used to stall the CPU if the coprocessor needs to hold off subsequent operations, has two sources-FPBusy and the external CpBusy pin which are logically ORed together. Further, Run and Exception of both the FPA and CPU are internally tied and brought out with the external CPBusy input to accommodate off chip coprocessor 2 and 3. This external interface is available to support application specific functions.

Tag Mode 1	Tag Mode 0	Check Which TAGs	Ignore Which Tags
0	0	Tag (31:12)	None
0	1	Tag (27:12)	Tag (31:28)
1	0	Tag (31:16)	Tag (15:12)
1	1	Tag (27:16)	Tag (31:28;15:12)

2871 tbl 03

Table 3. Tag Disable Encoding

W Cycle	X Cycle	Y Cycle	Z Cycle	Action
X	X	X	"HIGH"	FPint driven onto CpCond(1)
"LOW"	"LOW"	"LOW"	"LOW"	Use Int(3) for Fpint
"LOW"	"LOW"	"HIGH"	"LOW"	Use Int(1) for Fpint
"LOW"	"HIGH"	"LOW"	"LOW"	Use Int(2) for Fpint
"LOW"	"HIGH"	"HIGH"	"LOW"	Use Int(0) for Fpint
"HIGH"	"LOW"	"LOW"	"LOW"	Use Int(4) for Fpint
"HIGH"	"LOW"	"HIGH"	"LOW"	Use Int(5) for Fpint
"HIGH"	"HIGH"	"LOW"	"LOW"	Reserved, Undefined
"HIGH"	"HIGH"	"HIGH"	"LOW"	Reserved, Undefined

2871 tbl 04

Table 4. Int(4) Encoding for Fpint

MULTIPROCESSING SUPPORT

The IDT79R3500 supports multiprocessing applications in a simple but effective way. Multiprocessing applications require cache coherency across the multiple processors. The IDT79R3500 offers two signals to support cache coherency: the first, MPStall, stalls the processor within two cycles of being received and keeps it from accessing the cache. This allows an external agent to snoop into the processor data cache. The second signal, MPInvalidate, causes the processor to write data on the data cache bus which indicates the externally addressed cache entry is invalid. Thus, a subsequent access to that location would result in a cache miss, and the data would be obtained from main memory.

The two MP signals would be generated by a external logic which utilizes a secondary cache to perform bus snooping functions. The IDT79R3500 does not impose an architecture for this secondary cache, but rather is flexible enough to support a variety of application specific architectures and still maintain cache coherency. Further, there is no impact on designs which do not require this feature. The IDT79R3500 further allows the use of cache RAMs with internal address latches in multiprocessor systems.

ADVANCED FEATURES

The IDT79R3500 offers a number of additional features such as the ability to swap the instruction and data caches, facilitating diagnostics and cache flushing. Another feature isolates the caches, which forces cache hits to occur regardless of the contents of the tag fields. The IDT79R3500 allows the processor to execute user tasks of the opposite byte ordering (endianness) of the operating system, has a programmable Tag width bus, and further allows certain parity checking to be disabled. More details on these features can be found in the *IDT79R3000A Family Hardware User's Manual*.

Further features of the IDT79R3500 are configured during the last four cycles prior to the negation of the RESET input. These functions include the ability to select cache sizes and cache refill block sizes; the ability to utilize the multiprocessor interface; whether or not instruction streaming is enabled; whether byte ordering follows "Big-Endian" or "Little-Endian" protocols, etc. Additionally, the IDT79R3500 mode must be

true to enable any of the new features that the X,Y, and Z cycles define. Table 6 shows the configuration options selected at Reset. These are further discussed in the *IDT79R3000A Family Hardware User's Manual*.

BACKWARD COMPATIBILITY

The primary goal of the IDT79R3500 is the ability to replace the IDT79R3000A and IDT79R3010A with a single chip solution. The pinout of the IDT79R3500 has been selected to ensure this compatibility, with new functions mapped onto previously used pins. The instruction set is compatible with that of the R2000 at the binary level. As a result, code written for the older processor can be executed.

In most IDT79R3000A applications, the IDT79R3500 can be placed in the socket with no modification to initialization settings. Additionally, the IDT79R3500 can be used in systems that did not include the IDT79R3010 in the original design. Further application assistance on these topics are available from IDT.

PACKAGE THERMAL SPECIFICATIONS

The IDT79R3500 utilizes special packaging techniques to improve both the thermal and electrical characteristics of the microprocessor.

In order to improve the electrical characteristics of the device, the package is constructed using multiple signal planes, including individual power planes and ground planes to reduce noise associated with high-frequency TTL parts. In addition, the 161-pin PGA package utilizes extra power and ground pins to reduce the inductance from the internal power planes to the power planes of the PC Board.

In order to improve the thermal characteristics of the microprocessor, the device is housed using cavity down

packaging. In addition, these packages incorporate a copper-tungsten thermal slug designed to efficiently transfer heat from the die to the case of the package, and thus effectively lower the thermal resistance of the package. The use of an additional external heat sink affixed to the package thermal slug further decreases the effective thermal resistance of the package.

The case temperature may be measured in any environment to determine whether the device is within the specified operating range. The case temperature should be measured at the center of the top surface opposite the package cavity (the package cavity is the side where the package lid is mounted).

The equivalent allowable ambient temperature, TA, can be calculated using the thermal resistance from case to ambient (Θca) for the given package. The following equation relates ambient and case temperature:

$$T_A = T_c - P \cdot \Theta_{ca}$$

where P is the maximum power consumption, calculated by using the maximum Icc from the DC Electrical Characteristics section.

Typical values for Θca at various airflows are shown in Table 5 for the various CPU packages.

	Airflow - (ft/min)					
	0	200	400	600	800	1000
Θca (161-PGA)	21	7	3	2	1	0.5
Θca (160 MQUAD)	17	11	9	8	7	6.5

Table 5. R3500 Package Characteristics

2871 tbl 05



Input	W Cycle	X Cycle	Y Cycle	Z Cycle
Int0	DBIKSize0	DBIKSize1	Extend Cache	Big Endian
Int1	IBIKSize0	IBIKSize1	MPAdrDisable	TriState
Int2	DispPar/RevEnd	IStream	IgnoreParity	NoCache
Int3	Reserved ⁽¹⁾	StorePartial	MultiProcessor	BusDriveOn
Int4	FPINT decode	FPINT decode	FPINT decode	FPINT onto CpCond
Int5	7R3500 mode	TLB disable	Tag Mode 1	Tag Mode 0

NOTES:

1. Reserved entries must be driven high.
2. These values must be driven stable throughout the entire RESET period.

2871 tbl 06

Table 6. R3500 Mode Selectable Features

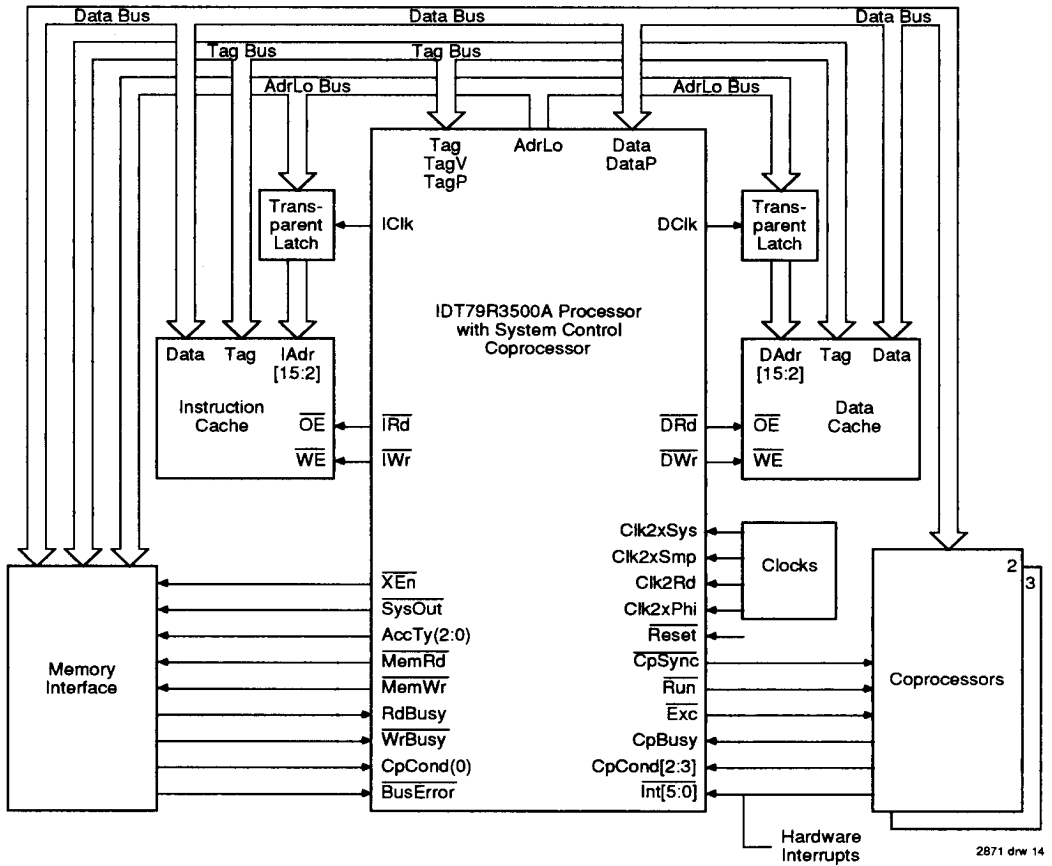

Figure 14. IDT79R3500 Subsystem Interfaces Example; 64 KB Caches

PIN CONFIGURATION

	1	2	3	4	5	6	7	8	9	10	11	12	13	14	15
A	(No Pin)	AdrLo 6	AdrLo 10	AdrLo 11	VCC	AdrLo 14	AdrLo 15	CpCond 0	AdrLo 16	AdrLo 17	$\overline{\text{Int}}(2)$	$\overline{\text{Int}}(5)$	Wr Busy	$\overline{\text{Reset}}$	VCC
B	AdrLo 3	$\overline{\text{DRd}}2$	AdrLo 7	AdrLo 9	AdrLo 12	$\overline{\text{IRd}}2$	AdrLo 13	CpCond 1	$\overline{\text{Int}}(1)$	$\overline{\text{Int}}(3)$	Cp Busy	$\overline{\text{Bus Error}}$	$\overline{\text{DWr}}2$	Tag12	Tag15
C	AdrLo 0	AdrLo 4	Mode	AdrLo 5	AdrLo 8	GND	GND	VCC	$\overline{\text{Int}}(0)$	$\overline{\text{Int}}(4)$	Rd Busy	GND	Tag13	TagP0	Tag18
D	Data 1	AdrLo 2	$\overline{\text{FpInt}}$	GND	VCC	GND	VCC	GND	VCC	GND	VCC	GND	Tag14	Tag17	Tag19
E	DataP 0	Data 0	AdrLo 1										Tag16	Tag20	VCC
F	VCC	Data 7	Data 2										GND	Tag21	Tag23
G	Data 4	Data 3	GND										GND	Tag22	TagP1
H	Data 6	Data 5	Data 8										VCC	Tag25	Tag24
J	Data 10	DataP 1	Data 9										Tag28	Tag29	Tag26
K	Data 15	Data 11	GND										GND	TagP2	Tag27
L	VCC	Data 12	Data 17										Acc Typ2	Tag31	Tag30
M	Data 13	Data 16	DataP 2	GND	VCC	GND	VCC	GND	VCC	GND	VCC	GND	GND	Acc Typ1	VCC
N	Data 14	Data 18	Data 19	GND	Data 24	DataP 3	VCC	VCC	GND	GND	$\overline{\text{DRd}}1$	Mem Wr	Mem Rd	$\overline{\text{Run}}$	TagV
P	Data 23	Data 20	$\overline{\text{IWr}}2$	Data 22	Data 26	Data 27	$\overline{\text{XEn}}$	Data 30	Clk2x Sys	Clk2x Rd	DClk	$\overline{\text{IRd}}1$	$\overline{\text{IWr}}1$	$\overline{\text{Cp Sync}}$	Acc Typ0
Q	VCC	Data 21	Data 25	Data 31	Data 28	GND	Data 29	Exception	Clk2x Phi	Clk2x Smp	$\overline{\text{SysOut}}$	VCC	IClk	$\overline{\text{DWr}}1$	VCC

5

NOTE:

1. AdrLo 16 and 17 are multifunction pins which are controlled by mode select programming on interrupt pins at reset time
 AdrLo 16: MP Invalidate, CpCond (2).
 AdrLo 17: MP Stall, CpCond (3).
2. This package is pin-compatible with the 175-pin PGA for the R3000A.

2871 drw 16

PIN CONFIGURATION

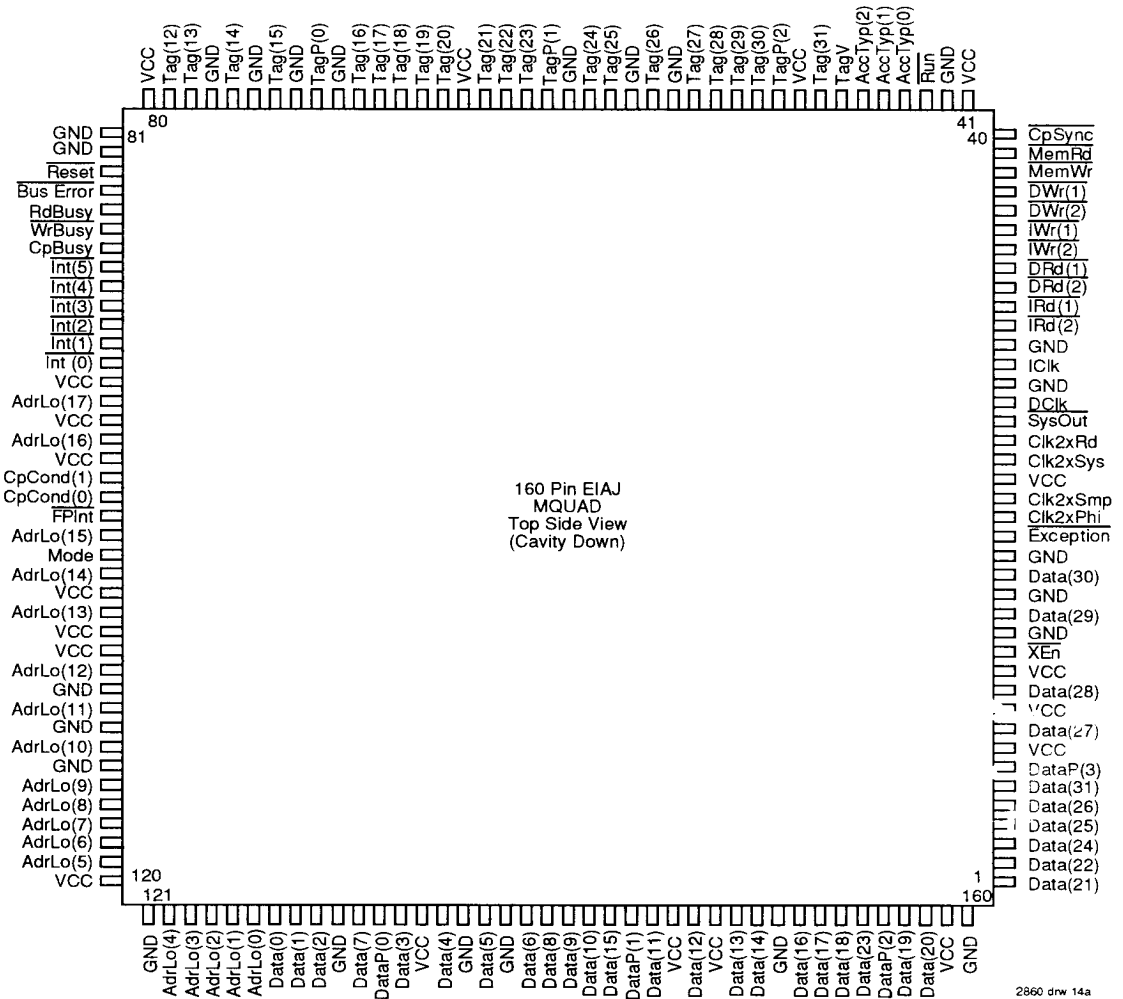

NOTE:

1. AdrLo 16 and 17 are multifunction pins which are controlled by mode select programming on interrupt pins at reset time
 AdrLo 16: MP Invalidate, CpCond (2).
 AdrLo 17: MP Stall, CpCond (3).
2. This package is pin-compatible with the 175-pin PGA for the R3000A.

PIN CONFIGURATION

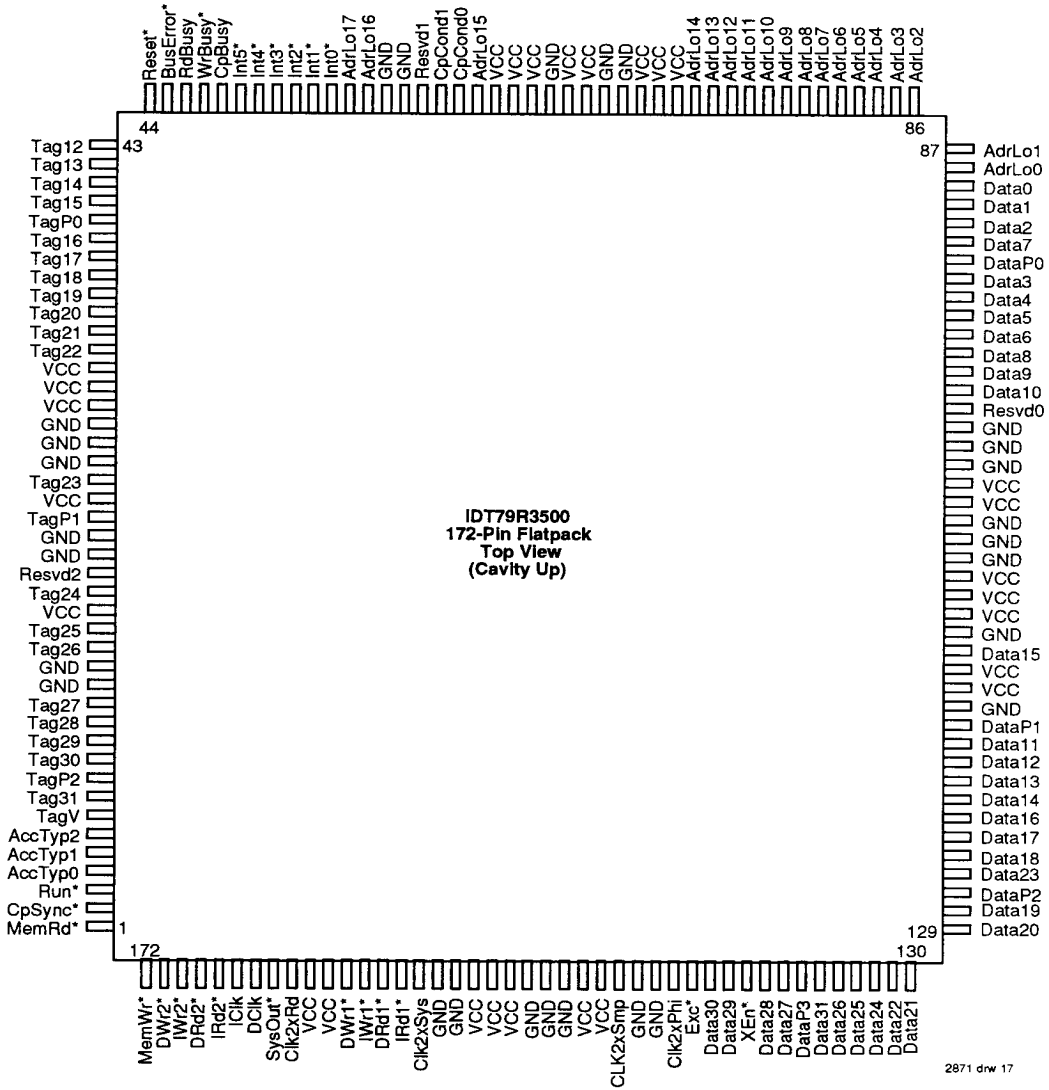

PIN DESCRIPTIONS

Pin Name	I/O	Description
Data (0-31)	I/O	A 32-bit bus used for all instruction and data transmission among the processor, caches, memory interface, and coprocessors.
DataP (0-3)	I/O	A 4-bit bus containing even parity over the data bus.
Tag (12-31)	I/O	A 20-bit bus used for transferring cache tags and high addresses between the processor, caches, and memory interface.
TagV	I/O	The tag validity indicator.
Tag P (0-2)	I/O	A 3-bit bus containing even parity over the concatenation of TagV and Tag.
AdrLo (0-17)	O	An 18-bit bus containing byte addresses used for transferring low addresses from the processor to the caches and memory interface. (AdrLo 16: CpCond (2), AdrLo 17: CpCond (3) set by reset initialization).
IRd1	O	Read enable for the instruction cache.
IWr1	O	Write enable for the instruction cache.
IRd2	O	An identical copy of IRd1 used to split the load.
IWr2	O	An identical copy of IWr1 used to split the load.
IClk	O	The instruction cache address latch clock. This clock runs continuously.
DRd1	O	The read enable for the data cache.
DWr1	O	The write enable for the data cache.
DRd2	O	An identical copy of DRd1 used to split the load.
DWr2	O	An identical copy of DWr1 used to split the load.
DClk	O	The data cache address latch clock. This clock runs continuously.
XEn	O	The read enable for the Read Buffer.
AccTyp(0-2)	O	A 3-bit bus used to indicate the size of data being transferred on the data bus, whether or not a data transfer is occurring, and the purpose of the transfer.
MemWr	O	Signals the occurrence of a main memory write.
MemRd	O	Signals the occurrence of a main memory read.
BusError	I	Signals the occurrence of a bus error during a main memory read or write.
Run	O	Indicates whether the processor is in the RUN or STALL state. In the discrete design, the R3000 Run output is tied directly to the R3010 Run input. In the IDT79R3500, this is done internally, but the Run signal is also brought out for application specific coprocessors.
Exception	O	Indicates that the instruction that is about to commit to a state change should be aborted; also indicates other exception related information. In the discrete design, the R3000 Exception output is tied to the IDT79R3010 Exception input. In the IDT79R3500 this is done internally, but the Exception signal is also brought out for application specific coprocessors.
CpSync	O	A clock which is identical to SysOut and used by external coprocessors for timing synchronization with the IDT79R3500. In the discrete design, CpSync output from the IDT79R3000 is tied to the IDT79R3010 FPSync input. In the IDT79R3500, this is done internally, but the CpSync signal is also brought out for application specific coprocessors.
RdBusy	I	The main memory read stall termination signal. In most system designs RdBusy is normally asserted and is deasserted only to indicate the successful completion of a memory read. RdBusy is sampled by the processor only during memory read stalls.
WrBusy	I	The main memory write stall initiation/termination signal.
CpBusy	I	Input used to indicate that the requested coprocessor resource is unavailable, or used to preserve the precise exception model. In the discrete design, CpBusy is driven directly by the R3010 FpBusy output. In the IDT79R3500 the CpBusy input of the CPU is the logical OR of both the internal FPA FpBusy and the external CpBusy pin. This input is provided for external application specific coprocessors. An internal pull down resistor is provided if this input is left open.
CpCond(1)	O	Signal used by the branch on Coprocessor 1 true/false instruction. In discrete systems using a IDT79R3010 FPA, this is normally tied to the FpCond output. In the IDT79R3500, the internal FpCond is directly tied to the internal CpCond(1) input leaving this pin available for other functions. This pin defaults to output the FpBusy internal signal or, (via the Reset vectors), output the FPInt—in the latter case, external hardware must route this signal to the appropriate int pin.
CpCond (0,2-3)	I	Conditional branch status from coprocessors to the processor. Function is provided on AdrLo 16/17 pins and is selected at reset time.
MPSStall	I	Multiprocessing Stall. Signals to the processor that it should stall accesses to the caches in a multiprocessing environment. This is physically the same pin as CpCond3; its use is determined at RESET initialization.
MPIinvalidate	I	Multiprocessing Invalidate. Signals to the processor that it should issue invalidate data on the cache data bus. The address to be invalidated is externally provided. This is the same pin as CpCond2; its use is determined at RESET initialization.
Int (0-5)	I	A 6-bit bus used by the memory interface and coprocessors to signal maskable interrupts to the IDT79R3500. This bus is also used at reset time to select among the mode-selectable features of the IDT79R3500. The FPA FPInt output signal is typically connected to one of these interrupt lines; the choice is programmable through the reset vectors with the default being Int(3).

PIN DESCRIPTIONS (Continued)

Pin Name	I/O	Description
Clk2xSys	I	The master double frequency input clock used for generating SysOut.
Clk2xSmp	I	A double frequency clock input used to determine the sample point for data coming into the processor and coprocessors.
Clk2xRd	I	A double frequency clock input used to determine the enable time of the cache RAMs.
Clk2xPhi	I	A double frequency clock input used to determine the position of the internal phases, phase1 and phase2.
Reset	I	Synchronous initialization input used to force execution starting from the reset memory address. Reset must be deasserted synchronously but asserted asynchronously. The deassertion of Reset must be synchronized by the leading edge of SysOut.
Mode	I	If the mode input is sampled as a '1' at the rising edge of reset, the connection between FpInt and the CPU interrupt bus will be established via the interrupt reset vector. Vcc should be used to establish this option. If mode is sampled as a 0 at the rising edge of reset, the FpInt will be an output, and must be externally connected back to a CPU interrupt input pin. Ground should be used to select this option.
FPINT	O	If the mode pin is sampled as a 0 at the rising edge of reset, this signal will be the FPInt output from the FPA core of the IDT79R3500, and must be externally connected back to a CPU interrupt pin. If the mode pin is sampled as a 1 at the rising edge of reset, this pin should be grounded.

2871 tbi 07

ABSOLUTE MAXIMUM RATINGS^(1, 3)

Symbol	Rating	Commercial	Military	Unit
VTERM	Terminal Voltage with Respect to GND	-0.5 to +7.0	-0.5 to +7.0	V
TA, TC	Operating Temperature	0 to +70 ⁽⁴⁾ (Ambient) 0 to +90 ⁽⁵⁾ (Case)	-55 to +125 (Case)	°C
TBIAS	Case Temperature Under Bias	-55 to +125 ⁽⁴⁾ 0 to +90 ⁽⁵⁾	-65 to +135	°C
TSTG	Storage Temperature	-55 to +125	-65 to +155	°C
VIN	Input Voltage	-0.5 to +7.0	-0.5 to +7.0	V

NOTES: 2871 tbi 08

- Stresses greater than those listed under ABSOLUTE MAXIMUM RATINGS may cause permanent damage to the device. This is a stress rating only and functional operation of the device at these or any other conditions above those indicated in the operational sections of this specification is not implied. Exposure to absolute maximum rating conditions for extended periods may affect reliability.
- VIN minimum = -3.0V for pulse width less than 15ns.
VIN should not exceed VCC +0.5 Volts.
- Not more than one output should be shorted at a time. Duration of the short should not exceed 30 seconds.
- 16-33 MHz only.
- 37-40 MHz only.

RECOMMENDED OPERATING TEMPERATURE AND SUPPLY VOLTAGE

Grade	Temperature	GND	Vcc
Military 20-25 MHz	-55°C to +125°C (Case)	0V	5.0 ±10%
Commercial 20-33 MHz	0°C to +70°C (Ambient)	0V	5.0 ±5%
Commercial 40 MHz	0°C to +90°C (Case)	0V	5.0 ±5%

2871 tbi 10

5

AC TEST CONDITIONS

Symbol	Parameter	Min.	Max.	Unit
V _{IH}	Input HIGH Voltage	3.0	---	V
V _{IL}	Input LOW Voltage	---	0.4	V
V _{IHS}	Input HIGH Voltage	3.5	---	V
V _{ILS}	Input LOW Voltage	---	0.4	V

2871 tbl 09

OUTPUT LOADING FOR AC TESTING

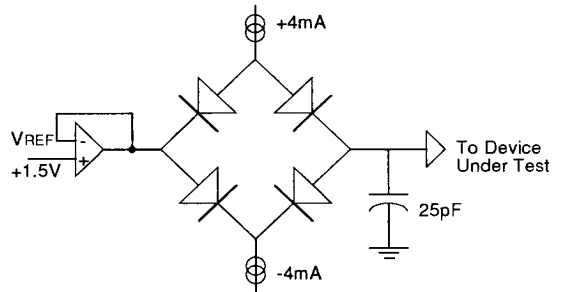

2871 drw 16

DC ELECTRICAL CHARACTERISTICS

COMMERCIAL TEMPERATURE RANGE (T_A = 0°C to +70°C, V_{CC} = +5.0V ±5%)

Symbol	Parameter	Test Conditions	79R3500						Unit
			20.0MHz		25.0MHz		33.33MHz		
			Min.	Max.	Min.	Max.	Min.	Max.	
V _{OH}	Output HIGH Voltage	V _{CC} = Min., I _{OH} = -4mA	3.5	---	3.5	---	3.5	---	V
V _{OL}	Output LOW Voltage	V _{CC} = Min., I _{OL} = 4mA	---	0.4	---	0.4	---	0.4	V
V _{OHc}	Output HIGH Voltage ⁽⁷⁾	V _{CC} = Min., I _{OH} = -4mA	4.0	---	4.0	---	4.0	---	V
V _{OHt}	Output HIGH Voltage ^(4,6)	V _{CC} = Min., I _{OH} = -8mA	2.4	---	2.4	---	2.4	---	V
V _{OLt}	Output LOW Voltage ^(4,6)	V _{CC} = Min., I _{OL} = 8mA	---	0.8	---	0.8	---	0.8	V
V _{IH}	Input HIGH Voltage ⁽⁵⁾		2.0	---	2.0	---	2.0	---	V
V _{IL}	Input LOW Voltage ⁽¹⁾		---	0.8	---	0.8	---	0.8	V
V _{IHS}	Input HIGH Voltage ^(2,5)		3.0	---	3.0	---	3.0	---	V
V _{ILS}	Input LOW Voltage ^(1,2)		---	0.4	---	0.4	---	0.4	V
C _{IN}	Input Capacitance ⁽⁶⁾		---	10	---	10	---	10	pF
C _{OUT}	Output Capacitance ⁽⁶⁾		---	10	---	10	---	10	pF
I _{CC}	Operating Current	V _{CC} = 5V, T _A = 70°C	---	550	---	650	---	750	mA
I _{IH}	Input HIGH Leakage ⁽³⁾	V _{IH} = V _{CC}	---	100	---	100	---	100	μA
I _{IL}	Input LOW Leakage ⁽³⁾	V _{IL} = GND	-100	---	-100	---	-100	---	μA
I _{OZ}	Output Tri-state Leakage	V _{OH} = V _{CC} , V _{OL} = GND	-100	100	-100	100	-100	100	μA

2871 tbl 11

NOTES:

- V_{IL} Min. = -3.0V for pulse width less than 15ns. V_{IL} should not fall below -0.5 Volts for larger periods.
- V_{IHS} and V_{ILS} apply to Clk2xSys, Clk2xSmp, Clk2xRd, Clk2xPhi, CpBusy, and Reset.
- These parameters do not apply to the clock inputs.
- V_{OHt} and V_{OLt} apply to the bidirectional data and tag busses only. Note that V_{IH} and V_{IL} also apply to these signals. V_{OHt} and V_{OLt} are provided to give the designer further information about these specific signals.
- V_{IH} should not be held above V_{CC} + 0.5 volts.
- Guaranteed by design.
- V_{OHc} applies to RUN and Exception.

DC ELECTRICAL CHARACTERISTICS

MILITARY TEMPERATURE RANGE (T_c = -55°C to +125°C, V_{CC} = +5.0V ±10%)

Symbol	Parameter	Test Conditions	79R3500				Unit
			20.0MHz		25.0MHz		
			Min.	Max.	Min.	Max.	
VOH	Output HIGH Voltage	V _{CC} = Min., I _{OH} = -4mA	3.5	—	3.5	—	V
VOL	Output LOW Voltage	V _{CC} = Min., I _{OL} = 4mA	—	0.4	—	0.4	V
VOHC	Output HIGH Voltage ⁽⁷⁾	V _{CC} = Min., I _{OH} = -4mA	4.0	—	4.0	—	V
VOHT	Output HIGH Voltage ^(4,6)	V _{CC} = Min., I _{OH} = -8mA	2.4	—	2.4	—	V
VOLT	Output LOW Voltage ^(4,6)	V _{CC} = Min., I _{OL} = 8mA	—	0.8	—	0.8	V
VIH	Input HIGH Voltage ⁽⁵⁾		2.0	—	2.0	—	V
VIL	Input LOW Voltage ⁽¹⁾		—	0.8	—	0.8	V
VIHS	Input HIGH Voltage ^(2,5)		3.0	—	3.0	—	V
VILS	Input LOW Voltage ^(1,2)		—	0.4	—	0.4	V
CIN	Input Capacitance ⁽⁶⁾		—	10	—	10	pF
COUT	Output Capacitance ⁽⁶⁾		—	10	—	10	pF
I _{CC}	Operating Current	V _{CC} = 5V, T _A = 70°C	—	800	—	875	mA
I _{IH}	Input HIGH Leakage ⁽³⁾	V _{IH} = V _{CC}	—	100	—	100	μA
I _{IL}	Input LOW Leakage ⁽³⁾	V _{IL} = GND	-100	—	-100	—	μA
I _{OZ}	Output Tri-state Leakage	V _{OH} = V _{CC} , V _{OL} = GND	-100	100	-100	100	μA

NOTES:

- V_{IL} Min. = -3.0V for pulse width less than 15ns. V_{IL} should not fall below -0.5 Volts for larger periods.
- V_{IHS} and V_{ILS} apply to Clk2xSys, Clk2xSmp, Clk2xRd, Clk2xPhi, CpBusy, and Reset.
- These parameters do not apply to the clock inputs.
- VOHT and VOLT apply to the bidirectional data and tag busses only. Note that V_{IH} and V_{IL} also apply to these signals. VOHT and VOLT are provided to give the designer further information about these specific signals.
- V_{IH} should not be held above V_{CC} + 0.5 volts.
- Tested only initially, and after design changes which may affect capacitance.
- VOHC applies to RUN and Exception.

2871 tbl 12

5

DC ELECTRICAL CHARACTERISTICS**COMMERCIAL TEMPERATURE RANGE** ($T_c = 0^\circ\text{C}$ to $+90^\circ\text{C}$, $V_{cc} = +5.0\text{V} \pm 5\%$)

Symbol	Parameter	Test Conditions	79R3500		Unit
			40.0MHz		
			Min.	Max.	
V _{OH}	Output HIGH Voltage	V _{CC} = Min., I _{OH} = -4mA	3.5	—	V
V _{OL}	Output LOW Voltage	V _{CC} = Min., I _{OL} = 4mA	—	0.4	V
V _{OHc}	Output HIGH Voltage ⁽⁷⁾	V _{CC} = Min., I _{OH} = -4mA	4.0	—	V
V _{OHt}	Output HIGH Voltage ^(4,6)	V _{CC} = Min., I _{OH} = -8mA	2.4	—	V
V _{OLt}	Output LOW Voltage ^(4,6)	V _{CC} = Min., I _{OL} = 8mA	—	0.8	V
V _{IH}	Input HIGH Voltage ⁽⁵⁾		2.0	—	V
V _{IL}	Input LOW Voltage ⁽¹⁾		—	0.8	V
V _{IHS}	Input HIGH Voltage ^(2,5)		3.0	—	V
V _{ILS}	Input LOW Voltage ^(1,2)		—	0.4	V
C _{IN}	Input Capacitance ⁽⁶⁾		—	10	pF
C _{OUT}	Output Capacitance ⁽⁶⁾		—	10	pF
I _{CC}	Operating Current	V _{CC} = 5V, T _A = 70°C	—	850	mA
I _{IH}	Input HIGH Leakage ⁽³⁾	V _{IH} = V _{CC}	—	100	μA
I _{IL}	Input LOW Leakage ⁽³⁾	V _{IL} = GND	-100	—	μA
I _{OZ}	Output Tri-state Leakage	V _{OH} = V _{CC} , V _{OL} = GND	-100	100	μA

2871 tbl 13

NOTES:

- V_{IL} Min. = -3.0V for pulse width less than 15ns. V_{IL} should not fall below -0.5 Volts for larger periods.
- V_{IHS} and V_{ILS} apply to Clk2xSys, Clk2xSmp, Clk2xRd, Clk2xPhi, CpBusy, and Reset.
- These parameters do not apply to the clock inputs.
- V_{OHt} and V_{OLt} apply to the bidirectional data and tag busses only. Note that V_{IH} and V_{IL} also apply to these signals. V_{OHt} and V_{OLt} are provided to give the designer further information about these specific signals.
- V_{IH} should not be held above V_{CC} + 0.5 volts.
- Guaranteed by design.
- V_{OHc} applies to RUN and Exception.

AC ELECTRICAL CHARACTERISTICS(1,2,3)

COMMERCIAL TEMPERATURE RANGE (TA = 0°C to +70°C, Vcc = +5.0V ±5%)

Symbol	Parameter	Test Conditions	79R3500						Unit
			20.0MHz		25.0MHz		33.33MHz		
			Min.	Max.	Min.	Max.	Min.	Max.	
Clock									
TckHigh	Input Clock HIGH ⁽²⁾	Note 6	10	—	8.0	—	6.0	—	ns
TckLow	Input Clock LOW ⁽²⁾	Note 6	10	—	8.0	—	6.0	—	ns
TckP	Input Clock Period ⁽²⁾		25	500	20	500	15	500	ns
	Clk2xSys to Clk2xSmp ⁽⁵⁾		0	tcyc/4	0	tcyc/4	0	tcyc/4	ns
	Clk2xSmp to Clk2xRd ⁽⁵⁾		0	tcyc/4	0	tcyc/4	0	tcyc/4	ns
	Clk2xSmp to Clk2xPhi ⁽⁵⁾		7.0	tcyc/4	5.0	tcyc/4	3.5	tcyc/4	ns
Run Operation									
TdEn	Data Enable ⁽³⁾		—	-2.0	—	-1.5	—	-1.5	ns
TDDIs	Data Disable ⁽³⁾		—	-1.0	—	-0.5	—	-0.5	ns
TDVal	Data Valid	Load= 25pF	—	3.0	—	2.0	—	2.0	ns
TwrDly	Write Delay	Load= 25pF	—	4.0	—	3.0	—	2.0	ns
Tds	Data Set-up		8.0	—	6.0	—	4.5	—	ns
TDH	Data Hold ⁽³⁾		-2.5	—	-2.5	—	-2.5	—	ns
TCBS	CpBusy Set-up		11	—	9.0	—	7.0	—	ns
TCBH	CpBusy Hold		-2.5	—	-2.5	—	-2.5	—	ns
TAcTy	Access Type (1:0)	Load= 25pF	—	6.0	—	5.0	—	3.5	ns
TAT2	Access Type (2)	Load= 25pF	—	14	—	12	—	8.5	ns
TMWr	Memory Write	Load= 25pF	—	23	—	18	—	9.5	ns
TExc	Exception	Load= 25pF	—	7.0	—	5.0	—	3.5	ns
TAval	Address Valid	Load= 25pF	—	2.0	—	1.5	—	1.0	ns
TIntS	Int(n) Set-up		8.0	—	6.0	—	4.5	—	ns
TIntH	Int(n) Hold		-2.5	—	-2.5	—	-2.5	—	ns
TFpbusy			—	13	—	10	—	7.0	ns
Tfpint			—	35	—	25	—	18	
Stall Operation									
TSAval	Address Valid	Load= 25pF	—	23	—	20	—	15	ns
TSAcTy	Access Type	Load= 25pF	—	23	—	18	—	13.5	ns
TMRdI	Memory Read Initiate	Load= 25pF	1.0	23	1.0	18	1.0	13.5	ns
TMRdT	Memory Read Terminate	Load= 25pF	—	23	—	18	—	10	ns
TStI	Run Terminate	Load= 25pF	3.0	15	3.0	10	2.0	7.5	ns
TRunI	Run Initiate	Load= 25pF	—	6.0	—	4.0	—	3.0	ns
TSMWr	Memory Write	Load= 25pF	3.0	23	3.0	18	2.0	9.5	ns
TSExc	Exception Valid	Load= 25pF	—	13	—	10	—	7.5	ns
Reset Initialization									
TRST	Reset Pulse Width		6.0	—	6.0	—	6.0	—	Tcyc
TprwOn	Power on ⁽⁴⁾		3000	—	3000	—	3000	—	Tcyc
Capacitive Load Deration									
CLD	Load Derate ⁽⁵⁾		0.5	1.0	0.5	1.0	0	1.0	ns/25pF

NOTES:

- All timings are referenced to 1.5V.
- The clock parameters apply to all four 2xClocks: Clk2xSys, Clk2xSmp, Clk2xRd, and Clk2xPhi.
- This parameter is guaranteed by design.
- Tcyc is one CPU clock cycle (two cycles of a 2x clock).
- With the exception of the Run signal, no two signals on a given device will derate for a given load by a difference greater than 15%.
- Clock transition time < 2.5ns for 33.33MHz, clock transition time < 5ns for other speeds.

2871 tbi 14

5

AC ELECTRICAL CHARACTERISTICS(1,2,3)

MILITARY TEMPERATURE RANGE (T_c = -55°C to +125°C, V_{cc} = +5.0V ±10%)

Symbol	Parameter	Test Conditions	79R3500				Unit
			20.0MHz		25.0MHz		
			Min.	Max.	Min.	Max.	
Clock							
TckHigh	Input Clock HIGH ⁽²⁾	Note 6	10	—	8.0	—	ns
TckLow	Input Clock LOW ⁽²⁾	Note 6	10	—	8.0	—	ns
TckP	Input Clock Period ⁽²⁾		25	500	20	500	ns
	Clk2xSys to Clk2xSmp ⁽⁵⁾		0	t _{cy} /4	0	t _{cy} /4	ns
	Clk2xSmp to Clk2xRd ⁽⁵⁾		0	t _{cy} /4	0	t _{cy} /4	ns
	Clk2xSmp to Clk2xPhi ⁽⁵⁾		7.0	t _{cy} /4	5.0	t _{cy} /4	ns
Run Operation							
TDEn	Data Enable ⁽³⁾		—	-2.0	—	-1.5	ns
TDDIs	Data Disable ⁽³⁾		—	-1.0	—	-0.5	ns
TDVal	Data Valid	Load= 25pF	—	3.0	—	3.0	ns
TwrDly	Write Delay	Load= 25pF	—	4.0	—	3.0	ns
TDS	Data Set-up		7.0	—	6.0	—	ns
TDH	Data Hold ⁽³⁾		-1.5	—	-1.5	—	ns
TCBS	CpBusy Set-up		11	—	9.0	—	ns
TCBH	CpBusy Hold		-1.5	—	-1.5	—	ns
TAcTy	Access Type (1:0)	Load= 25pF	—	6.0	—	5.0	ns
TAT2	Access Type (2)	Load= 25pF	—	14	—	12	ns
TMWr	Memory Write	Load= 25pF	—	23	—	18	ns
TExc	Exception	Load= 25pF	—	7.0	—	5.0	ns
TAval	Address Valid	Load= 25pF	—	2.5	—	2.0	ns
TIntS	Int(n) Set-up		7.0	—	6.0	—	ns
TIntH	Int(n) Hold		-1.5	—	-1.5	—	ns
Stall Operation							
TSAVal	Address Valid	Load= 25pF	—	23	—	20	ns
TSAcTy	Access Type	Load= 25pF	—	23	—	18	ns
TMRdi	Memory Read Initiate	Load= 25pF	1.0	23	—	18	ns
TMRdt	Memory Read Terminate	Load= 25pF	—	23	—	18	ns
TStt	Run Terminate	Load= 25pF	0.0	15	0.0	10	ns
TRun	Run Initiate	Load= 25pF	—	6.0	—	4.0	ns
TSMWr	Memory Write	Load= 25pF	0.0	23	0.0	18	ns
TSExc	Exception Valid	Load= 25pF	—	13	—	10	ns
Reset Initialization							
TRST	Reset Pulse Width		6.0	—	6.0	—	T _{cy}
TpwrOn	Power On ⁽⁴⁾		3000	—	3000	—	T _{cy}
Capacitive Load Deration							
CLD	Load Derate ⁽⁵⁾		0.5	1.0	0.5	1.0	ns/25pF

NOTES:

- All timings are referenced to 1.5V.
- The clock parameters apply to all four 2xClocks: Clk2xSys, Clk2xSmp, Clk2xRd, and Clk2xPhi.
- This parameter is guaranteed by design.
- T_{cy} is one CPU clock cycle (two cycles of a 2x clock).
- With the exception of the Run signal, no two signals on a given device will derate for a given load by a difference greater than 15%.
- Clock transition time < 2.5ns for 33.33MHz; clock transition time < 5ns for other speeds.

2871 tbl 15

AC ELECTRICAL CHARACTERISTICS^(1,2,3)COMMERCIAL TEMPERATURE RANGE (T_c = 0°C to +90°C, V_{CC} = +5.0V ±5%)

Symbol	Parameter	Test Conditions	79R3500		Unit
			40.0MHz		
			Min.	Max.	
Clock					
T _{ckHigh}	Input Clock HIGH ⁽²⁾	Note 6	5.0	—	ns
T _{ckLow}	Input Clock LOW ⁽²⁾	Note 6	5.0	—	ns
T _{ckP}	Input Clock Period ⁽²⁾		12.5	500	ns
	Clk2xSys to Clk2xSmp ⁽⁵⁾		0	t _{cyc} /4	ns
	Clk2xSmp to Clk2xRd ⁽⁵⁾		0	t _{cyc} /4	ns
	Clk2xSmp to Clk2xPhi ⁽⁵⁾		3.0	t _{cyc} /4	ns
Run Operation					
TDEn	Data Enable ⁽³⁾		—	-1.5	ns
TDDIs	Data Disable ⁽³⁾		—	-0.5	ns
TDVal	Data Valid	Load= 25pF	—	1.5	ns
TWrDly	Write Delay	Load= 25pF	—	2.0	ns
TDS	Data Set-up		4.0	—	ns
TDH	Data Hold ⁽³⁾		-2.5	—	ns
TCBS	CpBusy Set-up		6.0	—	ns
TCBH	CpBusy Hold		-2.5	—	ns
TAcTy	Access Type (1:0)	Load= 25pF	—	3.0	ns
TAT2	Access Type (2)	Load= 25pF	—	7.5	ns
TMWr	Memory Write	Load= 25pF	—	9.0	ns
TExc	Exception	Load= 25pF	—	3.0	ns
TAval	Address Valid	Load= 25pF	—	0.5	ns
TintS	Int(n) Set-up		4.0	—	ns
TintH	Int(n) Hold		-2.5	—	ns
T _l pbusy			—	6.0	ns
T _l point			—	17	ns
Stall Operation					
TSVal	Address Valid	Load= 25pF	—	12.5	ns
TSAcTy	Access Type	Load= 25pF	—	9.0	ns
TMRdi	Memory Read Initiate	Load= 25pF	—	9.0	ns
TMRdt	Memory Read Terminate	Load= 25pF	—	9.0	ns
TSll	Run Terminate	Load= 25pF	2.0	6.0	ns
TRun	Run Initiate	Load= 25pF	—	3.0	ns
TSMWr	Memory Write	Load= 25pF	2.0	9.0	ns
TSExc	Exception Valid	Load= 25pF	—	6.0	ns
Reset Initialization					
TRST	Reset Pulse Width		6.0	—	T _{cyc}
T _{pwr} On	Power On ⁽⁴⁾		3000	—	T _{cyc}
Capacitive Load Deration					
CLD	Load Derate ⁽⁵⁾		0	1.0	ns/25pF

NOTES:

- All timings are referenced to 1.5V.
- The clock parameters apply to all four 2xClocks: Clk2xSys, Clk2xSmp, Clk2xRd, and Clk2xPhi.
- This parameter is guaranteed by design.
- T_{cyc} is one CPU clock cycle (two cycles of a 2x clock).
- With the exception of the Run signal, no two signals on a given device will derate for a given load by a difference greater than 15%.
- Clock transition time < 2.5ns.

2871 tbl 16

5

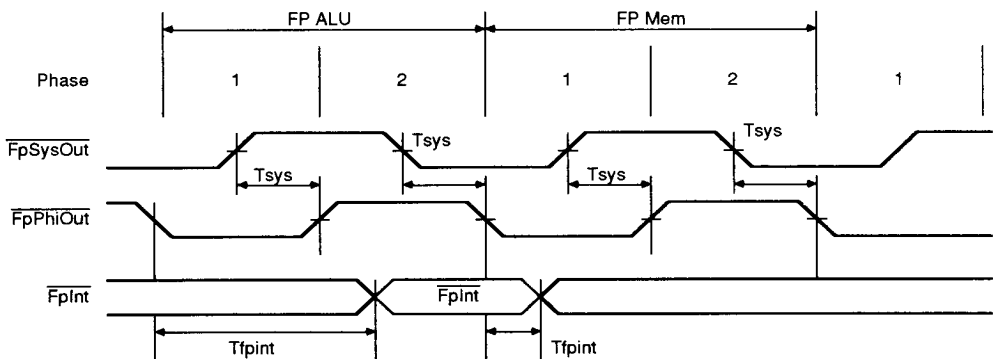

Figure 13. Floating Point Interrupt

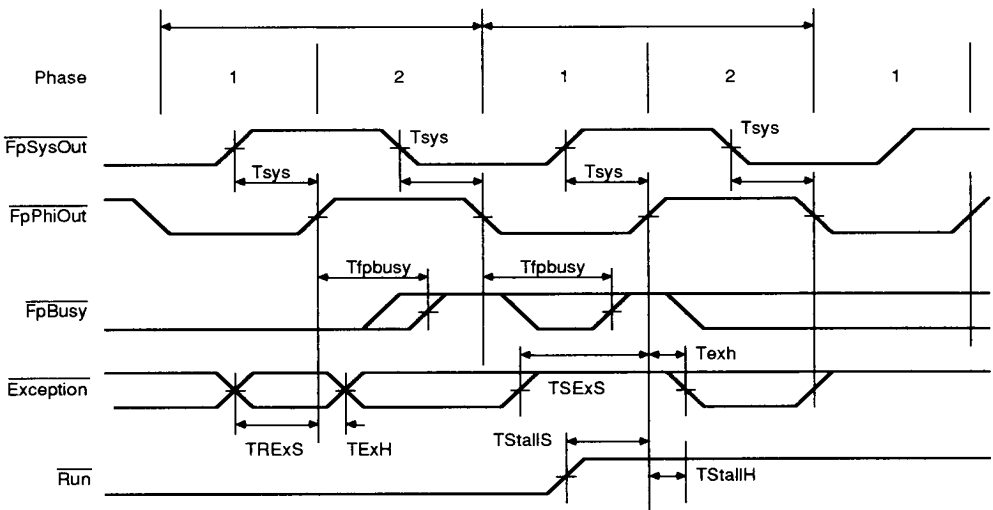
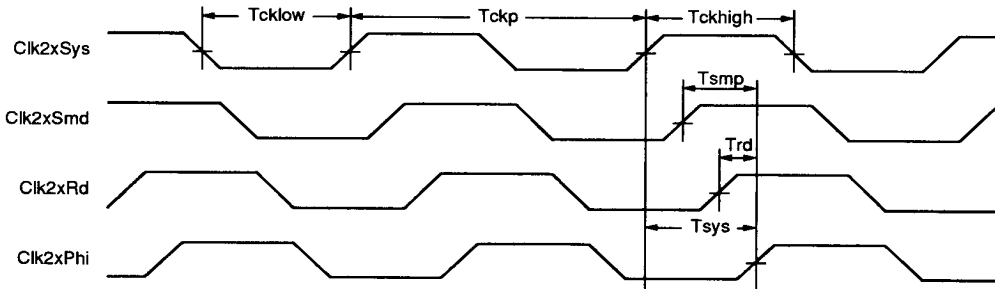
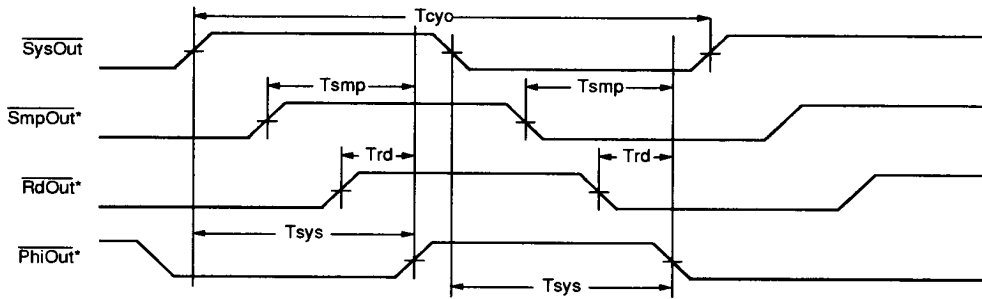

Figure 14. Floating Point Busy



2871 drw 19

Figure 15. Input Clock Timing



2871 drw 20

Figure 16. Processor Reference Clock Timing

* These signals are not actually output from the processor.
They are drawn to provide a reference for other timing diagrams.

5

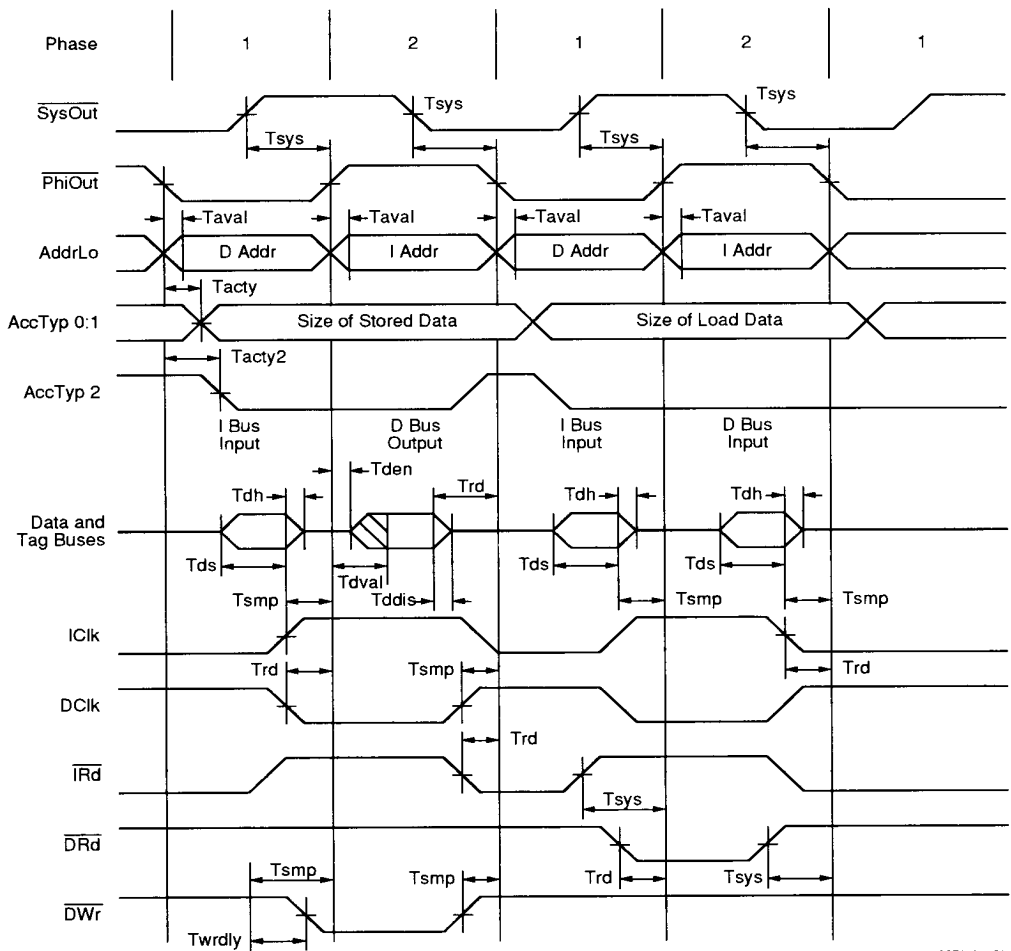

2871 drw 21

Figure 17. Synchronous Memory (Cache) Timing

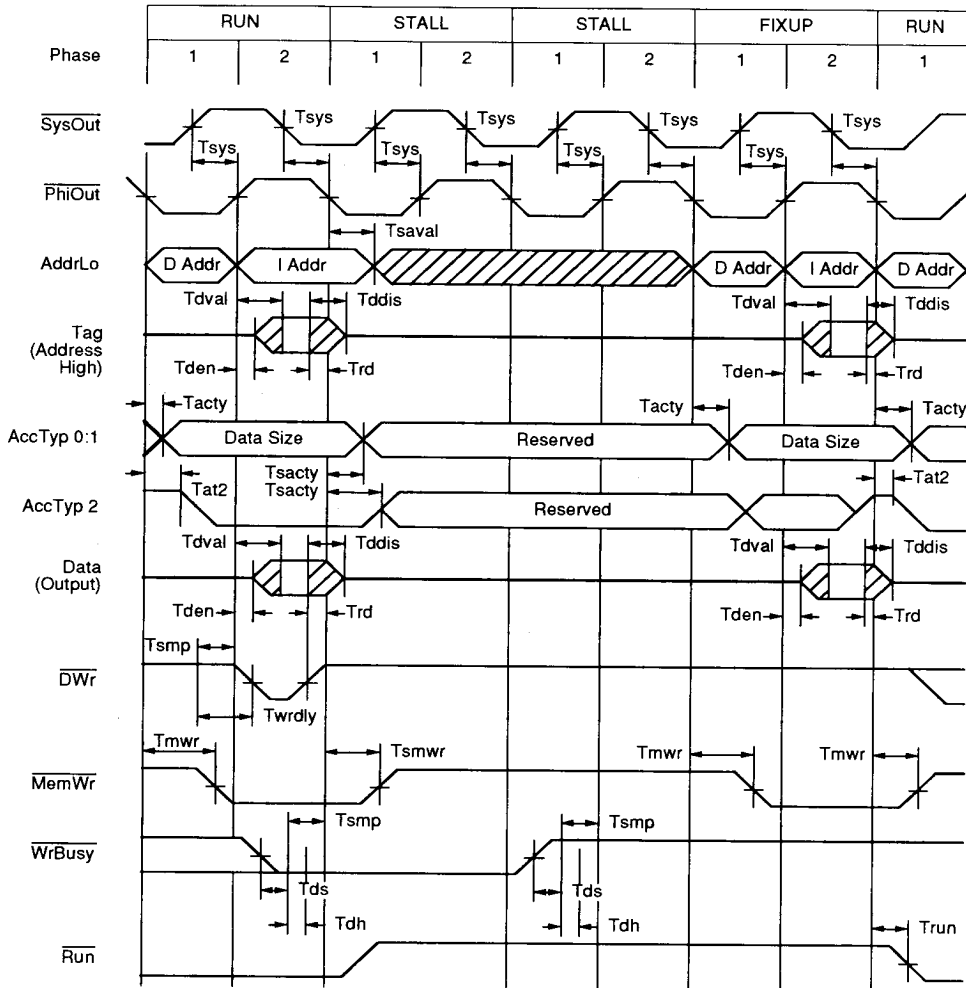

2871 drw 22

Figure 18. Memory Write Timing

5

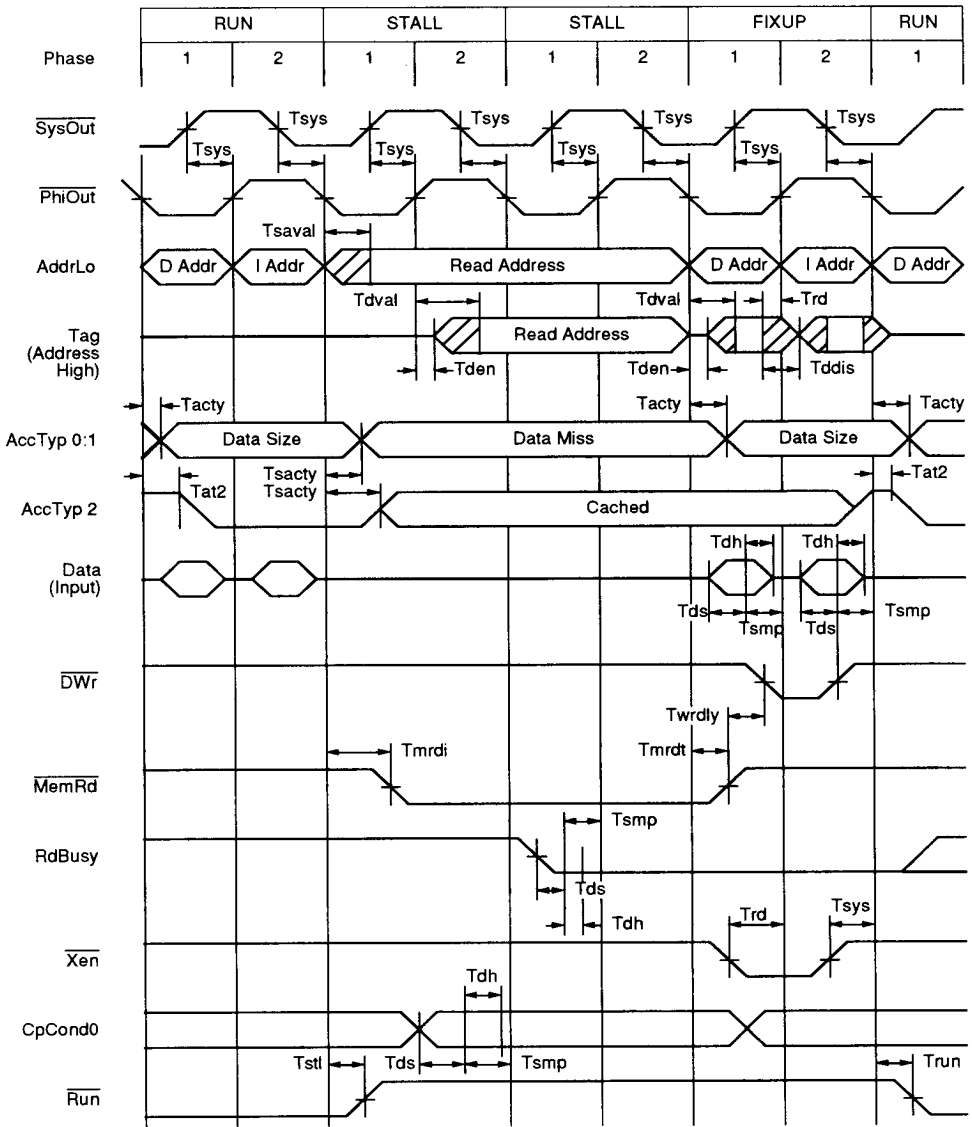

2871 drw 21

Figure 19. Memory Read Timing

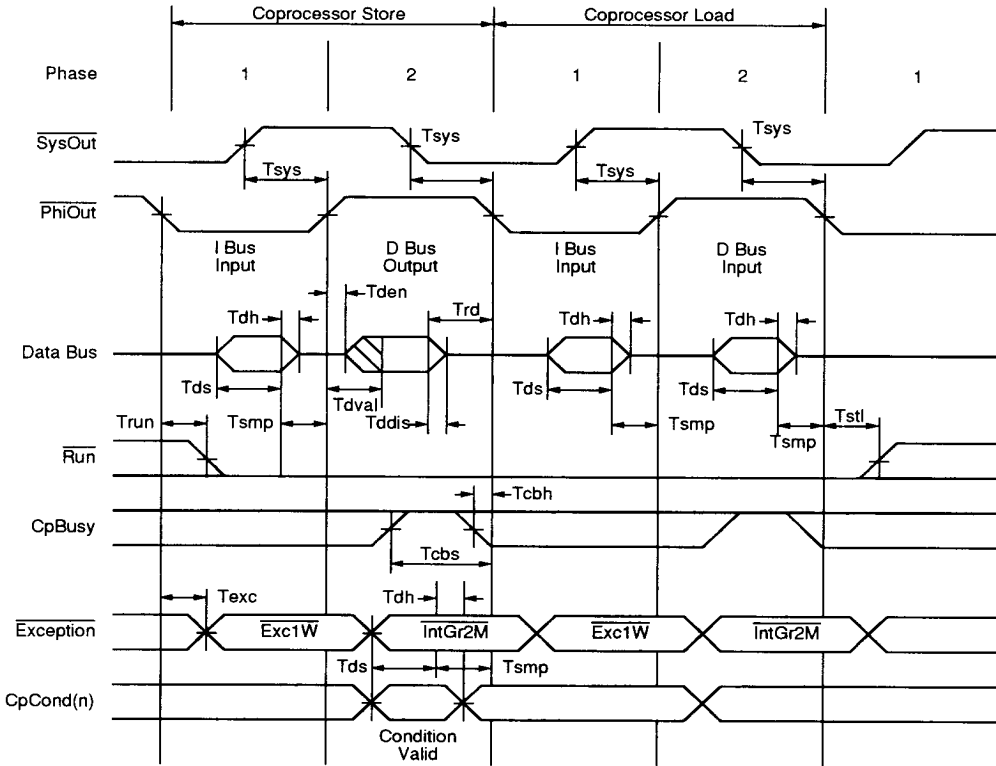

Figure 20. Coprocessor Load/Store Timing

2871 drw 22

5

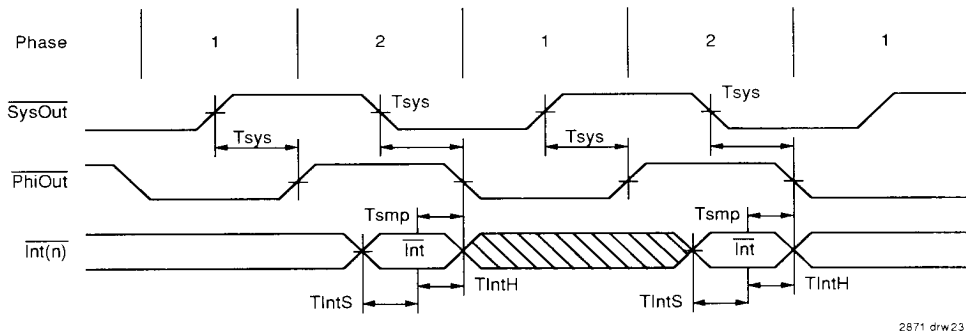

Figure 21. Interrupt Timing

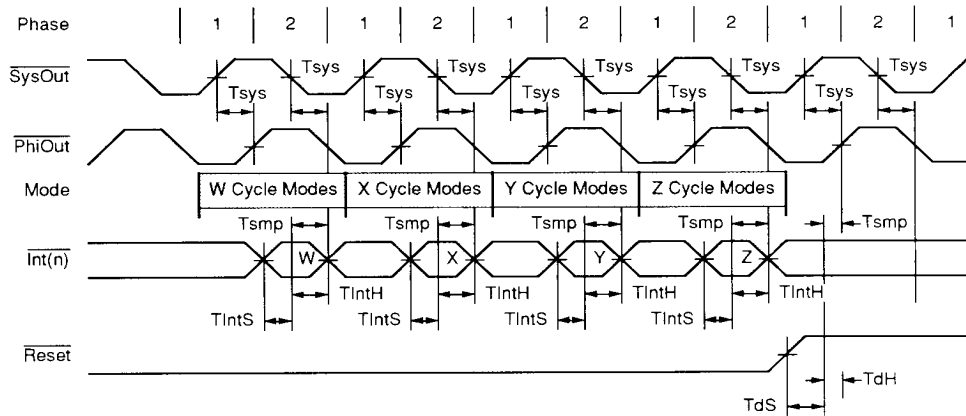
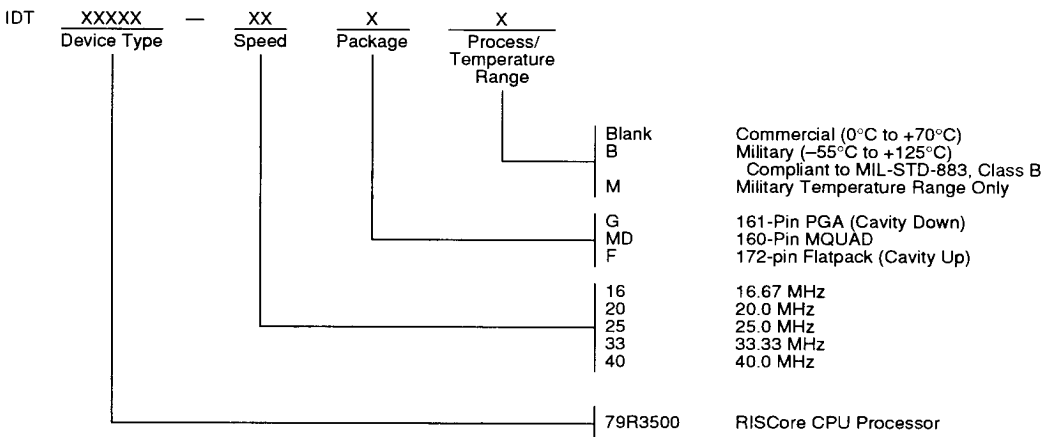

Figure 22. Mode Vector Initialization

NOTES:

1. Reset must be negated synchronously; however, it should be asserted asynchronously. Designs must not rely on the proper functioning of SysOut prior to the assertion of Reset.
2. Reset is actually sampled in both Phase 1 and Phase 2. To insure proper initialization, it must be negated relative to the end of Phase 1.

ORDERING INFORMATION



2871 drw 27

VALID COMBINATIONS

IDT	79R3500 - 20,25,33,40	G, MD
	79R3500 - 20,25,-B,M	G, F

