

---

---

**Converting A 5.0V Supply Rail To A Regulated 3.0V**

---

---

<i>Author: Cliff Ellison Microchip Technology Inc.</i>
--

**INTRODUCTION**

As system designers are forced to produce products with increased features while maintaining a flat or decreasing product cost, advancements in device technology must be considered. To produce Integrated Circuits (IC) with increased functionality at a reasonable cost, IC manufacturers need to reduce the overall silicon area. However, the functional and cost benefits associated with smaller areas can not be achieved without some system design trade-offs. These smaller geometry ICs typically have a maximum voltage rating of 3.0V or below, instead of the existing maximum 5.0V rating.

This application note is intended to provide the system designer with an overview of different options that could be used to down convert an existing 5.0V system rail to a regulated 3.0V.

The approaches discussed in this application note are the Low Dropout Regulator (LDO), charge pump and buck switch mode converter. Other options exist, but they do not provide a regulated 3.0V. A summary of these options, as well as a reference section containing detailed design application note titles and data sheets, appears at the end of the document.

**LOW DROPOUT REGULATOR**

A simple way of converting the 5.0V bus voltage to the required regulated 3.0V is by using a low dropout regulator. An LDO is nothing more than a three terminal linear system providing closed-loop control. The solution is easy to implement, requiring only the device itself and an input and output capacitor.

**LDO Operation**

In Figure 1, we can see that an LDO is built from four main elements: 1) pass transistor, 2) bandgap reference, 3) operational amplifier, and 4) feedback resistors. An LDO can be thought of as a variable resistor. The output voltage is divided down by the resistor divider and compared to a fixed bandgap reference voltage. The operational amplifier controls the drive to the pass transistor accordingly to equalize the voltage on its inputs. The difference between the bus voltage and the required output voltage is dropped across the pass transistor. When the pass transistor, shown as a P-Channel MOSFET, is turned fully ON, there will be some finite amount of resistance and therefore a voltage drop. This minimum voltage drop,  $V_{DROPOUT}$ , will set how much higher the bus voltage needs to be when compared to the output voltage in order to regulate the output.

**Designing With An LDO**

Generating a well regulated 3.0V output is very easy with an LDO. There are just a couple of specifications that the circuit designer should take into consideration when using an LDO. One specification is the output voltage. Many LDOs are supplied in standard fixed output voltages which typically include 3.0V. However, some LDOs are offered with an adjustable output voltage. This requires the designer to use an external feedback resistor divider.

Another LDO specification is the typical dropout voltage at load. The sum of the output voltage and the typical dropout voltage must be less than the minimum input voltage. If the sum is greater, the LDO will not be able to regulate the output at minimum input voltages.

A very important specification that should not be overlooked is the requirements that some LDOs place on the output capacitor. Certain LDOs require the output capacitor to be either tantalum or aluminum electrolytic to produce a stable system. These capacitors have a large Equivalent Series Resistance (ESR) when compared to ceramic capacitors. Tantalum or aluminum electrolytic capacitors are normally cheaper than ceramic capacitors when a large value of capacitance is needed, but they are also usually larger in size.

# AN1025

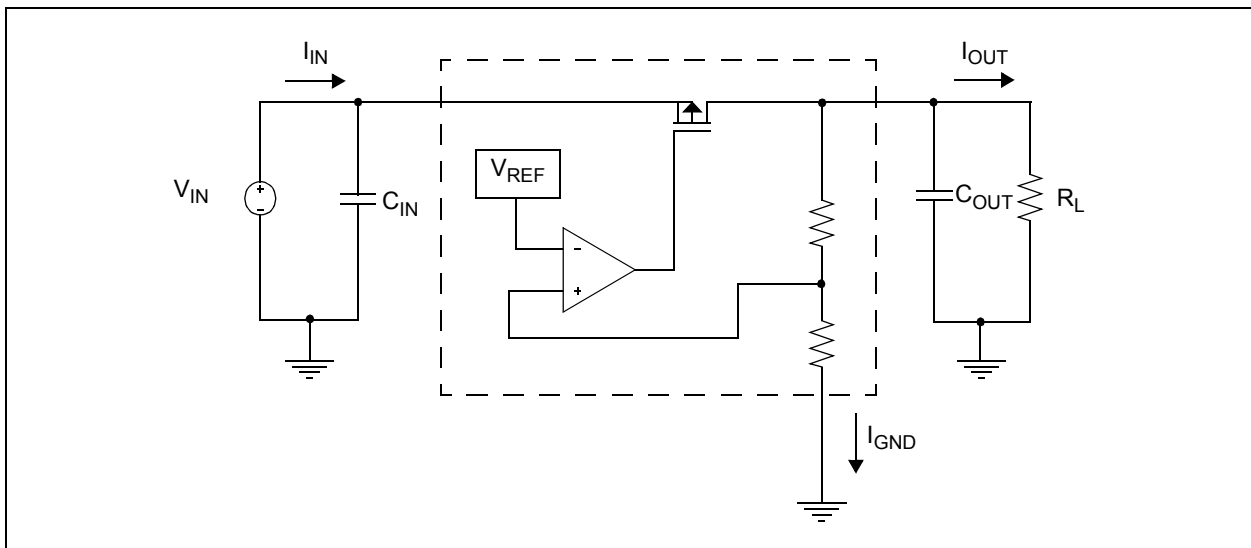

**FIGURE 1:** Basic LDO System Schematic.

## Understanding LDO $I_{GND}$ Specifications

There are three current elements,  $I_{IN}$ ,  $I_{OUT}$  and  $I_{GND}$ , labeled in Figure 1.  $I_{GND}$  is the current used by the LDO to perform the regulating operation and is often referred to as the quiescent current ( $I_q$ ) for no load conditions. Since the specified  $I_q$  varies greatly depending on the specific LDO or particular manufacture, it is important to understand how this one specification impacts the system performance.

An LDO can form a very efficient step-down regulator. When the LDO output current is much greater than the device quiescent current, the system efficiency is found by dividing the output voltage by the input voltage. This is shown in Equation 1.

### EQUATION 1:

$$Efficiency = \frac{V_{OUT}}{V_{IN}}$$

When:  $I_{GND} \ll I_{OUT}$

System efficiency at lighter load currents is one of the impacts  $I_q$  has on the system performance. In basic terms, an LDO with a low  $I_q$  will only be more efficient at lighter loads. This is because as the load current increases, the  $I_q$  is only a small percentage of the total  $I_{IN}$ . The efficiency of two Microchip LDOs, the MCP1700 and TC1017, is shown in Figure 2. Notice how the efficiency of the MCP1700 is vastly greater than the TC1017 at light loads since the TC1017 has a higher  $I_q$ .

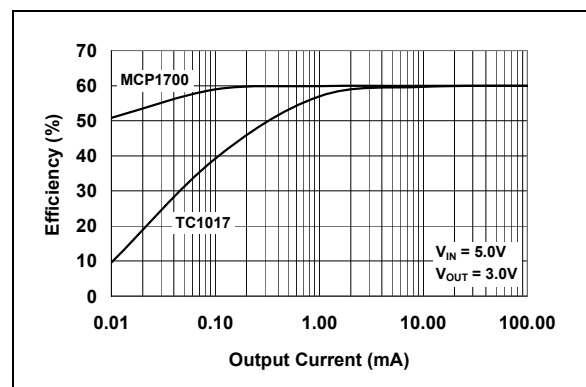

**FIGURE 2:** LDO Efficiency Comparison.

System line and load step performance is greatly improved on LDOs that have higher  $I_q$ . Since the  $I_q$  is used by the LDO to perform the regulating operation, it can respond quicker to a sudden change in load requirements or line voltage.

## CHARGE PUMP

A charge pump is another regulator topology that can be used to convert a 5.0V system rail voltage down to a regulated 3.0V to be used by microcontrollers or other logic. Charge pumps, also referred to as an inductor-less DC-DC converter or a switched-capacitor circuit, are just as easy to use as LDOs. Like an LDO, a charge pump requires an input and output capacitor and a feedback resistor divider network. However, charge pumps require an additional charge storing capacitor which is sometimes referred to as a fly capacitor.

There are many different types of charge pumps. Some of the more common types are: voltage inverting, voltage doubling, regulated buck, regulated boost and regulated buck/boost. The regulated buck charge pump is the only type that is discussed in this application note. For information on the other types of charge pumps, refer to the Microchip web site at [www.microchip.com](http://www.microchip.com).

## Regulated Buck Charge Pump Operation

Microchip's MCP1252/3 is a positive regulated charge pump that, like most charge pumps, uses four MOSFET switches to control the charge and discharge of the fly capacitor and thereby regulates the output voltage. However, unlike most charge pumps, the MCP1252/3 allows for the source voltage to be lower or higher than the output voltage by automatically switching between buck/boost operation. For the purpose of this application note, the Buck mode is the only operating state that is discussed. Refer to the MCP1252/3 Data Sheet (DS21752) for a full description of the buck/boost operation.

In Figure 3, it can be seen that the internal comparator U1, determines which mode the MCP1252/3 operates in. While in Buck mode, the positive input node is greater than the negative input node, switch SW1 is always closed, and SW2 is always open. When the MCP1252/3 is not in Shutdown mode and a steady-state condition has been reached, there are three phases of operation. During the first phase, charge is transferred from the input source to  $C_{FLY}$  by closing switch SW3 for half of the internal oscillator period. Once the first phase is complete, all switches are opened and the second phase (idle phase) is entered. The MCP1252/3 compares the reference voltage,  $V_{REF}$ , with the feedback voltage. If the feedback voltage is below the regulation point, the device transitions to the third phase. The third phase transitions charge from  $C_{FLY}$  to the output capacitor,  $C_{OUT}$ , and the load by closing switch SW4. If regulation is maintained, the device returns to the idle phase. If the charge transfer occurs for half of the internal oscillator period, more charge is needed in  $C_{FLY}$  and the MCP1252/3 transitions back to the first phase.

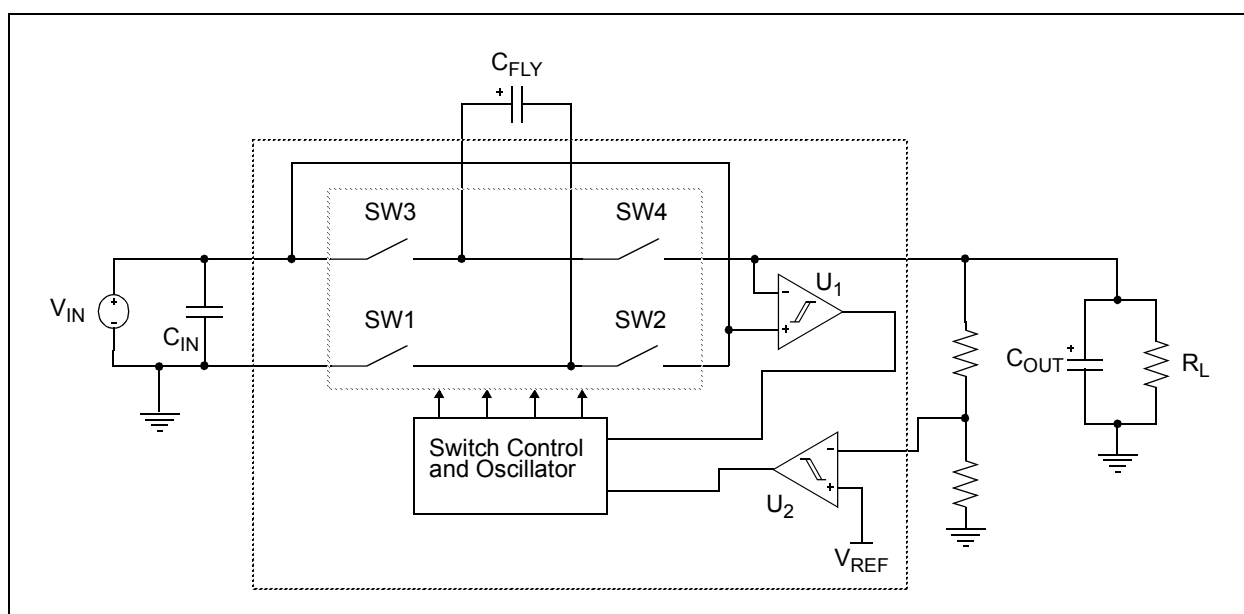

**FIGURE 3:** MCP1252/3 Charge Pump System Schematic.

# AN1025

## Designing with a Charge Pump

Output voltage ripple and charge pump strength are affected by the style and value of the capacitors used. Typically, low ESR capacitors should be used for the input and output capacitors. This helps minimize noise and ripple in the system.

The value of the input capacitor is somewhat dictated by the system voltage supply. If the source impedance to the charge pump is very low, the input capacitor might not be needed. However, if there is a large source impedance, an input capacitor is needed to help prevent ripple on the input voltage pin.

Output voltage ripple is controlled by the amount of capacitance in the output capacitor. Large values of output capacitance will reduce the output ripple at the expense of a slower turn-on time from shutdown and a higher in-rush current.

The fly capacitor controls the strength of the charge pump. However, care must be taken when selecting the value of this capacitor. Recall that the maximum charge time for the fly capacitor is one half the charge pump oscillator frequency and when charging, it is in series with the ON resistance of two switches. The charging time constant of this RC circuit should be less than the maximum charge time.

## BUCK SWITCHING REGULATOR

One of the simplest switch mode converters is the buck converter. The buck converter is an inductor-based converter used to step-down an input voltage to a lower magnitude output voltage. It is similar to the LDO circuit previously discussed, but with one main difference. Instead of the pass transistor that functions as a variable resistor in the LDO, the MOSFET in a buck converter is either ON or OFF. The regulation of the output voltage is achieved by controlling the ON and OFF time of this MOSFET. This allows the buck regulator to convert a high source voltage to a regulated lower output voltage efficiently.

### Buck Converter Operation

A basic buck regulator schematic is shown in Figure 4. A typical buck regulator consist of a switching MOSFET, an inductor, output capacitor and a recirculating diode. During a switching cycle, the MOSFET,  $Q_1$ , transitions between an ON state and an OFF state. Assume the buck regulator is operating in steady-state and  $Q_1$  is in the ON state. The voltage across the inductor,  $L_1$ , is equal to the input voltage,  $V_{IN}$ , minus the output voltage,  $V_{OUT}$ . Energy is being stored in  $L_1$ . At the end of the ON time,  $t_{ON}$ ,  $Q_1$  transitions to an OFF state. The voltage across  $L_1$  collapses, changing polarity to a value equal to  $-V_{OUT}$ . The energy in  $L_1$  is now decreasing and suppling the output requirements.  $Q_1$  remains OFF until the end of the period. This complete cycle is then repeated.

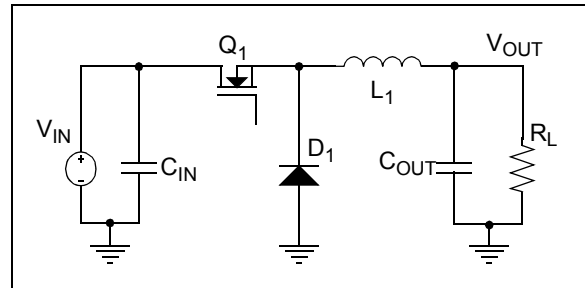

**FIGURE 4:** Buck Regulator System Schematic.

Understanding the operation of the buck converter and realizing that the volt-time across the inductor in the ON time must equal the inductor volt-time in the OFF time allows a relationship between the input voltage and output voltage to be established. This input to output voltage relationship is shown in Equation 2.

### EQUATION 2:

$$DutyCycle = \frac{V_{OUT}}{V_{IN}}$$

Where:

$$Duty\ Cycle = t_{ON} / (t_{ON} + t_{OFF})$$

## Synchronous Buck Converters

When a buck converter is used to generate low output voltages, the recirculating diode,  $D_1$  in Figure 4, can be replaced with another MOSFET and is switched out-of-phase with the main MOSFET. By doing so, the overall system efficiency is improved. For example, a buck converter is used to generate an output voltage of 3.0V and  $D_1$  has a forward voltage drop,  $V_{FD}$ , of 0.75V. There would be approximately an initial 25% decrease in the buck converters maximum efficiency because of the diode's  $V_{FD}$ . The efficiency degradation would be worse with a lower output voltage.

Microchip offers a number of synchronous buck converter regulators. Devices like the MCP1601 or MCP1612 integrate both the main switching MOSFET and the synchronous MOSFET. Figure 5 shows an adjustable output voltage, synchronous buck converter. The items in the dashed box are contained within the buck IC. Another Microchip device, the TC1303, contains both a synchronous buck regulator with integrated MOSFETs and an LDO.

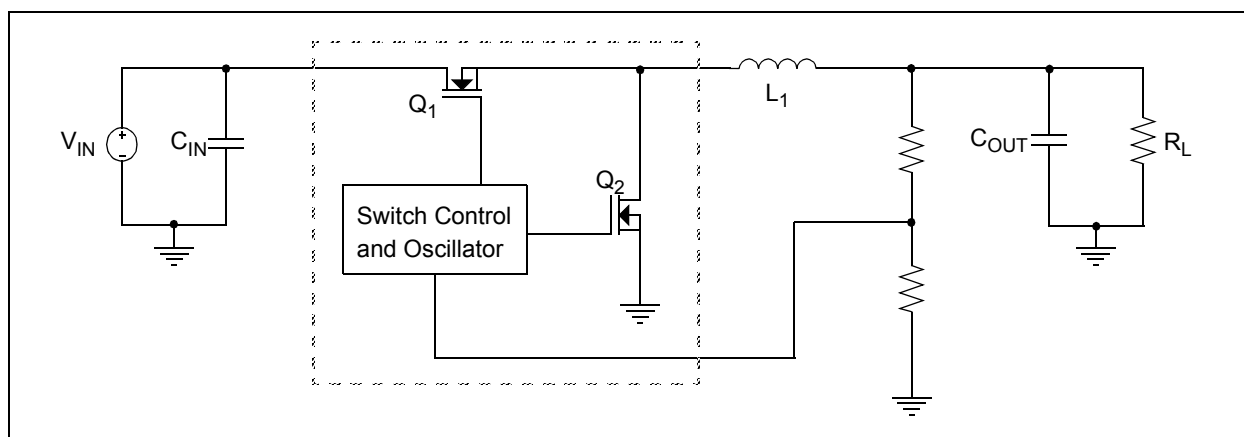

**FIGURE 5:** Synchronous Buck Converter.

## SUMMARY

This application note has provided the system designer with an overview of different options used to produce a regulated 3.0V from a 5.0V system rail. Key highlights of each option were discussed, but often it is important to compare the advantages of one particular solution over another.

As a system designer, an LDO might be chosen because of its lower cost, smaller size, ease-of-use, or low system noise generation. However, under certain conditions, the extra power that needs to be dissipated in an LDO might overshadow these advantages.

The biggest advantage of using charge pumps is no inductor is required. Regulation is accomplished by transferring charge from the fly capacitor to the output. The low output current capability of a charge pump might prohibit a charge pump from being chosen for heavy load applications.

A buck switch mode converter offers the advantages of being the highest efficiency when  $V_{IN}$  is much greater than  $V_{OUT}$  and capable of supplying higher output current levels. With the integration of the MOSFETs and control circuitry into a buck regulator IC, designing a buck converter is relatively simple to accomplish. However, an inductor and output capacitor are required causing the parts count to be slightly higher than other options.

Deciding which option to use when converting an existing 5.0V system rail to a regulated 3.0V ultimately lays with the specific application requirements.

## REFERENCES

MCP1601 Data Sheet, "500 mA Synchronous BUCK Regulator", DS21762, Microchip Technology Inc., 2003

MCP1612 Data Sheet, "Single 1A, 1.4 MHz Synchronous Buck Regulator", DS21921, Microchip Technology Inc., 2005

TC1303A/TC1303B — TC1303C/TC1304 Data Sheet, "500 mA Synchronous Buck Regulator, + 300 mA LDO with Power-Good Output", DS21949, Microchip Technology Inc., 2005

MCP1252/53 Data Sheet, "Low Noise, Positive-Regulated Charge Pump", DS21752, Microchip Technology Inc., 2002

MCP1700 Data Sheet, "Low Quiescent Current LDO", DS21826, Microchip Technology Inc., 2003

TC1017 Data Sheet, "150 mA, Tiny CMOS LDO With Shutdown", DS21813, Microchip Technology Inc., 2005

AN793 Application Note, "Power Management in Portable Applications: Understanding the Buck Switch Mode Power Converter", DS00793, Microchip Technology Inc., 2001

AN968 Application Note, "Simple Synchronous Buck Converter Design - MCP1612", DS00968, Microchip Technology Inc., 2005

AN960 Application Note, "New Components and Design Methods Bring Intelligence to Battery Charger Applications", DS00960, Microchip Technology Inc., 2004

MCP1601 Buck Regulator Evaluation Board, MCP1601EV, Microchip Technology Inc., 2004

MCP1612 Synchronous Buck Regulator Evaluation Board, MCP1612EV, Microchip Technology Inc., 2005

TC1303B Buck Regulator LDO Demo Board, TC1303BDM-DDBK1, Microchip Technology Inc., 2005

TC1016/17 LDO Linear Regulator Evaluation Board, TC1016/17EV, Microchip Technology Inc., 2005

# AN1025

---

NOTES:

---

---

**Note the following details of the code protection feature on Microchip devices:**

- Microchip products meet the specification contained in their particular Microchip Data Sheet.
- Microchip believes that its family of products is one of the most secure families of its kind on the market today, when used in the intended manner and under normal conditions.
- There are dishonest and possibly illegal methods used to breach the code protection feature. All of these methods, to our knowledge, require using the Microchip products in a manner outside the operating specifications contained in Microchip's Data Sheets. Most likely, the person doing so is engaged in theft of intellectual property.
- Microchip is willing to work with the customer who is concerned about the integrity of their code.
- Neither Microchip nor any other semiconductor manufacturer can guarantee the security of their code. Code protection does not mean that we are guaranteeing the product as "unbreakable."

Code protection is constantly evolving. We at Microchip are committed to continuously improving the code protection features of our products. Attempts to break Microchip's code protection feature may be a violation of the Digital Millennium Copyright Act. If such acts allow unauthorized access to your software or other copyrighted work, you may have a right to sue for relief under that Act.

---

Information contained in this publication regarding device applications and the like is provided only for your convenience and may be superseded by updates. It is your responsibility to ensure that your application meets with your specifications. MICROCHIP MAKES NO REPRESENTATIONS OR WARRANTIES OF ANY KIND WHETHER EXPRESS OR IMPLIED, WRITTEN OR ORAL, STATUTORY OR OTHERWISE, RELATED TO THE INFORMATION, INCLUDING BUT NOT LIMITED TO ITS CONDITION, QUALITY, PERFORMANCE, MERCHANTABILITY OR FITNESS FOR PURPOSE. Microchip disclaims all liability arising from this information and its use. Use of Microchip devices in life support and/or safety applications is entirely at the buyer's risk, and the buyer agrees to defend, indemnify and hold harmless Microchip from any and all damages, claims, suits, or expenses resulting from such use. No licenses are conveyed, implicitly or otherwise, under any Microchip intellectual property rights.

**Trademarks**

The Microchip name and logo, the Microchip logo, Accuron, dsPIC, KEELOQ, microID, MPLAB, PIC, PICmicro, PICSTART, PRO MATE, PowerSmart, rfPIC, and SmartShunt are registered trademarks of Microchip Technology Incorporated in the U.S.A. and other countries.

AmpLab, FilterLab, Migratable Memory, MXDEV, MXLAB, PICMASTER, SEEVAL, SmartSensor and The Embedded Control Solutions Company are registered trademarks of Microchip Technology Incorporated in the U.S.A.

Analog-for-the-Digital Age, Application Maestro, dsPICDEM, dsPICDEM.net, dsPICworks, ECAN, ECONOMONITOR, FanSense, FlexROM, fuzzyLAB, In-Circuit Serial Programming, ICSP, ICEPIC, Linear Active Thermistor, MPASM, MPLIB, MPLINK, MPSIM, PICKit, PICDEM, PICDEM.net, PICLAB, PICTail, PowerCal, PowerInfo, PowerMate, PowerTool, Real ICE, rLAB, rfPICDEM, Select Mode, Smart Serial, SmartTel, Total Endurance, UNI/O, WiperLock and Zena are trademarks of Microchip Technology Incorporated in the U.S.A. and other countries.

SQTP is a service mark of Microchip Technology Incorporated in the U.S.A.

All other trademarks mentioned herein are property of their respective companies.

© 2006, Microchip Technology Incorporated, Printed in the U.S.A., All Rights Reserved.

 Printed on recycled paper.

**QUALITY MANAGEMENT SYSTEM**  
**CERTIFIED BY DNV**  
**== ISO/TS 16949:2002 ==**

*Microchip received ISO/TS-16949:2002 quality system certification for its worldwide headquarters, design and wafer fabrication facilities in Chandler and Tempe, Arizona and Mountain View, California in October 2003. The Company's quality system processes and procedures are for its PICmicro® 8-bit MCUs, KEELOQ® code hopping devices, Serial EEPROMs, microperipherals, nonvolatile memory and analog products. In addition, Microchip's quality system for the design and manufacture of development systems is ISO 9001:2000 certified.*



---

## WORLDWIDE SALES AND SERVICE

---

### AMERICAS

**Corporate Office**  
2355 West Chandler Blvd.  
Chandler, AZ 85224-6199  
Tel: 480-792-7200  
Fax: 480-792-7277  
Technical Support:  
<http://support.microchip.com>  
Web Address:  
[www.microchip.com](http://www.microchip.com)

#### Atlanta

Alpharetta, GA  
Tel: 770-640-0034  
Fax: 770-640-0307

#### Boston

Westborough, MA  
Tel: 774-760-0087  
Fax: 774-760-0088

#### Chicago

Itasca, IL  
Tel: 630-285-0071  
Fax: 630-285-0075

#### Dallas

Addison, TX  
Tel: 972-818-7423  
Fax: 972-818-2924

#### Detroit

Farmington Hills, MI  
Tel: 248-538-2250  
Fax: 248-538-2260

#### Kokomo

Kokomo, IN  
Tel: 765-864-8360  
Fax: 765-864-8387

#### Los Angeles

Mission Viejo, CA  
Tel: 949-462-9523  
Fax: 949-462-9608

#### San Jose

Mountain View, CA  
Tel: 650-215-1444  
Fax: 650-961-0286

#### Toronto

Mississauga, Ontario,  
Canada  
Tel: 905-673-0699  
Fax: 905-673-6509

### ASIA/PACIFIC

**Australia - Sydney**  
Tel: 61-2-9868-6733  
Fax: 61-2-9868-6755

**China - Beijing**  
Tel: 86-10-8528-2100  
Fax: 86-10-8528-2104

**China - Chengdu**  
Tel: 86-28-8676-6200  
Fax: 86-28-8676-6599

**China - Fuzhou**  
Tel: 86-591-8750-3506  
Fax: 86-591-8750-3521

**China - Hong Kong SAR**  
Tel: 852-2401-1200  
Fax: 852-2401-3431

**China - Qingdao**  
Tel: 86-532-8502-7355  
Fax: 86-532-8502-7205

**China - Shanghai**  
Tel: 86-21-5407-5533  
Fax: 86-21-5407-5066

**China - Shenyang**  
Tel: 86-24-2334-2829  
Fax: 86-24-2334-2393

**China - Shenzhen**  
Tel: 86-755-8203-2660  
Fax: 86-755-8203-1760

**China - Shunde**  
Tel: 86-757-2839-5507  
Fax: 86-757-2839-5571

**China - Wuhan**  
Tel: 86-27-5980-5300  
Fax: 86-27-5980-5118

**China - Xian**  
Tel: 86-29-8833-7250  
Fax: 86-29-8833-7256

### ASIA/PACIFIC

**India - Bangalore**  
Tel: 91-80-4182-8400  
Fax: 91-80-4182-8422

**India - New Delhi**  
Tel: 91-11-5160-8631  
Fax: 91-11-5160-8632

**India - Pune**  
Tel: 91-20-2566-1512  
Fax: 91-20-2566-1513

**Japan - Yokohama**  
Tel: 81-45-471-6166  
Fax: 81-45-471-6122

**Korea - Gumi**  
Tel: 82-54-473-4301  
Fax: 82-54-473-4302

**Korea - Seoul**  
Tel: 82-2-554-7200  
Fax: 82-2-558-5932 or  
82-2-558-5934

**Malaysia - Penang**  
Tel: 60-4-646-8870  
Fax: 60-4-646-5086

**Philippines - Manila**  
Tel: 63-2-634-9065  
Fax: 63-2-634-9069

**Singapore**  
Tel: 65-6334-8870  
Fax: 65-6334-8850

**Taiwan - Hsin Chu**  
Tel: 886-3-572-9526  
Fax: 886-3-572-6459

**Taiwan - Kaohsiung**  
Tel: 886-7-536-4818  
Fax: 886-7-536-4803

**Taiwan - Taipei**  
Tel: 886-2-2500-6610  
Fax: 886-2-2508-0102

**Thailand - Bangkok**  
Tel: 66-2-694-1351  
Fax: 66-2-694-1350

### EUROPE

**Austria - Wels**  
Tel: 43-7242-2244-399  
Fax: 43-7242-2244-393

**Denmark - Copenhagen**  
Tel: 45-4450-2828  
Fax: 45-4485-2829

**France - Paris**  
Tel: 33-1-69-53-63-20  
Fax: 33-1-69-30-90-79

**Germany - Munich**  
Tel: 49-89-627-144-0  
Fax: 49-89-627-144-44

**Italy - Milan**  
Tel: 39-0331-742611  
Fax: 39-0331-466781

**Netherlands - Druen**  
Tel: 31-416-690399  
Fax: 31-416-690340

**Spain - Madrid**  
Tel: 34-91-708-08-90  
Fax: 34-91-708-08-91

**UK - Wokingham**  
Tel: 44-118-921-5869  
Fax: 44-118-921-5820