

## Silicon PNP Power Transistors

2SB1411

## DESCRIPTION

- With TO-220F package
- DARLINGTON
- High DC current gain
- Low collector saturation voltage

## APPLICATIONS

- Switching applications
- Hammer drive ,pulse motor drive applications

## PINNING

PIN	DESCRIPTION
1	Base
2	Collector
3	Emitter

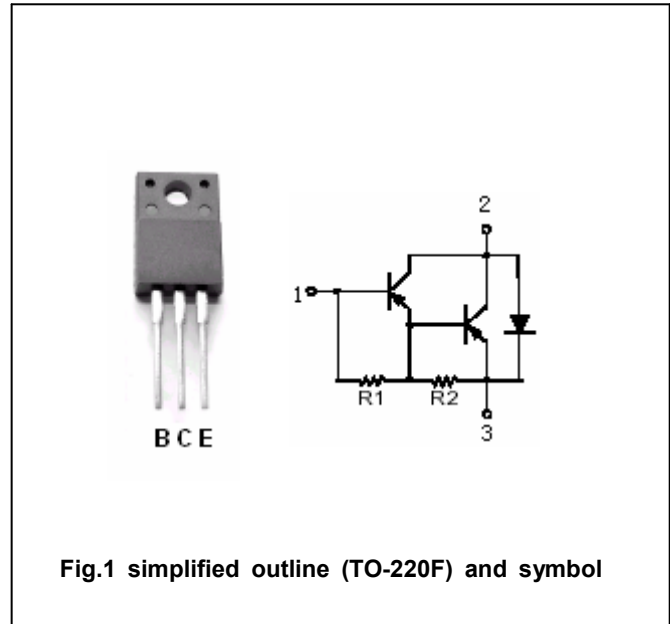

## Absolute maximum ratings (Ta=25℃)

SYMBOL	PARAMETER	CONDITIONS	VALUE	UNIT
V <sub>CBO</sub>	Collector-base voltage	Open emitter	-100	V
V <sub>CEO</sub>	Collector-emitter voltage	Open base	-100	V
V <sub>EBO</sub>	Emitter-base voltage	Open collector	-7	V
I <sub>C</sub>	Collector current		-2	A
I <sub>CM</sub>	Collector current-peak		-3	A
I <sub>B</sub>	Base current		-0.5	A
P <sub>C</sub>	Collector power dissipation	T <sub>C</sub> =25℃	20	W
T <sub>j</sub>	Junction temperature		150	℃
T <sub>stg</sub>	Storage temperature		-55~150	℃

## Silicon PNP Power Transistors

## 2SB1411

## CHARACTERISTICS

T<sub>j</sub>=25°C unless otherwise specified

SYMBOL	PARAMETER	CONDITIONS	MIN	TYP.	MAX	UNIT
V <sub>(BR)CEO</sub>	Collector-emitter breakdown voltage	I <sub>C</sub> =-50mA ; I <sub>B</sub> =0	-110			V
V <sub>CEsat</sub>	Collector-emitter saturation voltage	I <sub>C</sub> =-5A; I <sub>B</sub> =-5mA			-2.5	V
V <sub>BEsat</sub>	Base-emitter saturation voltage	I <sub>C</sub> =-5A; I <sub>B</sub> =-5mA			-3.0	V
I <sub>CBO</sub>	Collector cut-off current	V <sub>CB</sub> =-110V; I <sub>E</sub> =0			-0.1	mA
I <sub>EBO</sub>	Emitter cut-off current	V <sub>EB</sub> =-5V; I <sub>C</sub> =0			-0.1	mA
h <sub>FE</sub>	DC current gain	I <sub>C</sub> =-5A ; V <sub>CE</sub> =-4V	5000			
f <sub>T</sub>	Transition frequency	I <sub>C</sub> =-0.5A ; V <sub>CE</sub> =-12V		100		MHz
C <sub>OB</sub>	Collector output capacitance	f=1MHz; V <sub>CB</sub> =-10V		110		pF

## Switching times

t <sub>on</sub>	Turn-on time	I <sub>C</sub> =-5A I <sub>B1</sub> =-I <sub>B2</sub> =-5mA V <sub>CC</sub> =30V ,R <sub>L</sub> =6Ω		1.1		μs
t <sub>s</sub>	Storage time			3.2		μs
t <sub>f</sub>	Fall time			1.1		μs

◆ h<sub>FE</sub> Classifications

O	p	Y
5000-12000	6500-20000	15000-30000

Silicon PNP Power Transistors

2SB1411

PACKAGE OUTLINE

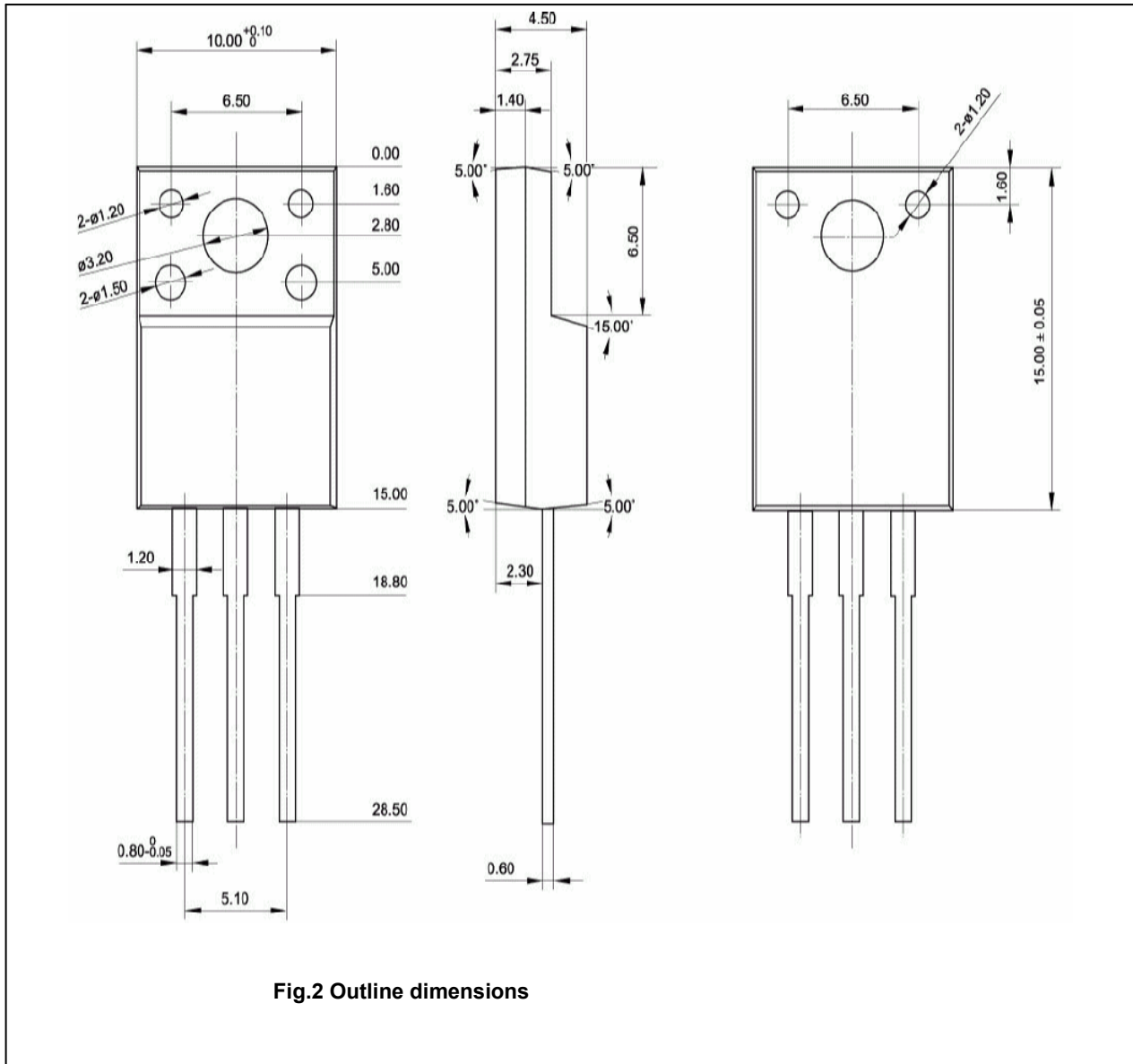

Fig.2 Outline dimensions