

PLEASE CHECK WWW.MOLEX.COM FOR LATEST PART INFORMATION

Part Number: **0191930198**
Status: **Active**
Description: VersaKrimp™ Ring Tongue Terminal for 8 AWG Wire

Documents:

[Drawing \(PDF\)](#) [RoHS Certificate of Compliance \(PDF\)](#)

Agency Certification

CSA LR18689
 UL E32244

General

Product Family Ring and Spade Terminals
 Series [19193](#)
 Crimp Quality Equipment Yes
 Mil-Spec N/A
 MolexKits Yes
 Product Name VersaKrimp™
 Type Ring

Physical

Barrel Type Closed - Brazed
 Insulation None
 Material - Plating Mating Tin
 Packaging Type Bag
 Stud Size 6 (M3.5)
 Termination Interface: Style Crimp or Compression
 Wire Size AWG 8
 Wire Size mm² 0.60 - 10.5

Material Info

Old Part Number D-356-06

Reference - Drawing Numbers

Sales Drawing SD-19193-012

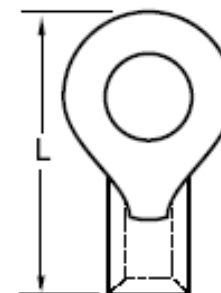

image - Reference only

Series

EU RoHS

ELV and RoHS Compliant
REACH SVHC Contains SVHC: No
Halogen-Free Status

China RoHS



Halogen-Free

Need more information on product environmental compliance?

Email productcompliance@molex.com
 For a multiple part number RoHS Certificate of Compliance, [click here](#)

Please visit the [Contact Us](#) section for any non-product compliance questions.

Search Parts in this Series

[19193Series](#)

Application Tooling | [FAQ](#)

Tooling specifications and manuals are found by selecting the products below. Crimp Height Specifications are then contained in the Application Tooling Specification document.

Global

Description	Product #
Manual Putt Pump Hydraulic System, Die set required	0192860117
Die Set (large) for the HHLS Hydraulic Crimper	0192900001
Putt Pump Dieless Head System	0192860065
Hand Crimp Tool	0640013900
Crimp Head for the AT-200™ Pneumatic Hand Tool	0640074400

This document was generated on 06/07/2010

PLEASE CHECK WWW.MOLEX.COM FOR LATEST PART INFORMATION

MATERIAL NUMBER	ENGINEERING NUMBER	STUD SIZE	"S" ±.003/(0.08)	PACKAGING
191930198	D-356-06	6	.146/(3.71)	LOOSE PIECE
191930200	D-356-08	8	.173/(4.39)	
191930202	D-356-10	10	.198/(5.03)	
191930204	D-356-14	14	.265/(6.73)	
191930199	D-356-06T	6	.146/(3.71)	TAPE
191930201	D-356-08T	8	.173/(4.39)	
191930203	D-356-10T	10	.198/(5.03)	
191930205	D-356-14T	14	.265/(6.73)	

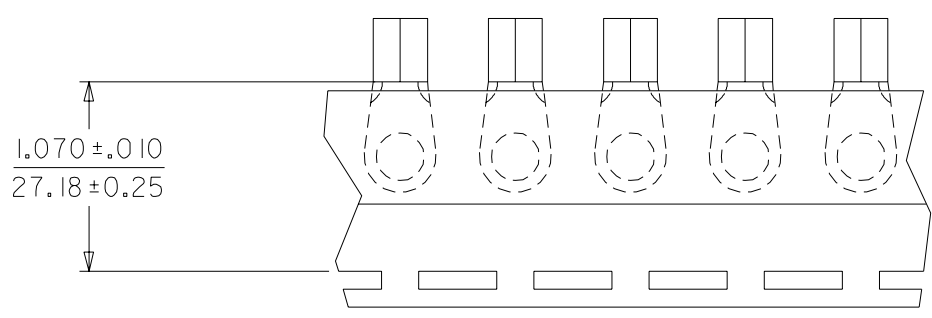

TAPE MOUNTING LOCATION

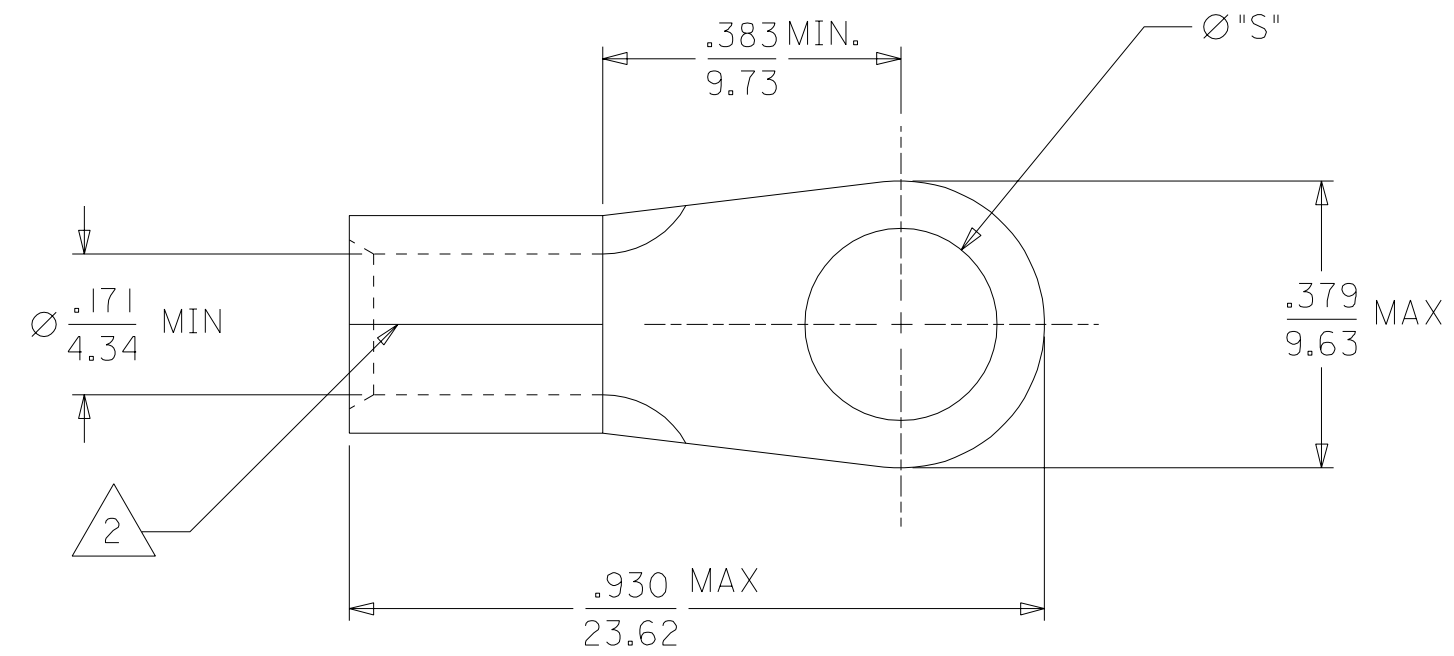

SALES DRAWING

NOTES:
 1. MATERIAL: COPPER
 PLATING: ELECTRO-TIN.
 2. BRAZED SEAM.

WAS SD-19069-012 EC NO. ETC2003-0333 DRWN: BRE 03/06/23 CHK: HEB 03/06/23 APPR: RWD 03/06/23	QUALITY SYMBOLS	GENERAL TOLERANCES: (UNLESS SPECIFIED)	SCALE 4:1	DESIGN UNITS <input type="checkbox"/> mm <input checked="" type="checkbox"/> INCH	THIRD ANGLE PROJECTION	DIMENSIONS: <input type="checkbox"/> mm <input checked="" type="checkbox"/> INCH <input type="checkbox"/> mm ONLY	SHT	REV	
	MAJOR =0	mm	INCH	DRAWN BY & DATE BRE 03/06/18	TITLE: RING TONGUE TERMINAL				
	CRITICAL =0	4 PLACES ±0.	±.	CHECKED BY & DATE HEB 03/06/18	VERSAKRIMP				
		3 PLACES ±0.	±.	APPROVED BY & DATE RWD 03/06/18	8 AWG				
	2 PLACES ±0.	±.	ANGULAR: ±1/2°	CAD FILENAME SD-19193-012 .S01	MATERIAL NO. SEE CHART	DRAWING NO. SD-19193-012	SHEET NO. 1 OF 1		
	1 PLACE ±0.	±.	DRAFT WHERE APPLICABLE MUST REMAIN WITHIN DIMENSIONS	THIS DRAWING CONTAINS INFORMATION THAT IS PROPRIETARY TO MOLEX INCORPORATED AND SHOULD NOT BE USED WITHOUT WRITTEN PERMISSION.					
				MOLEX INCORPORATED					
				SIZE B					