

# TYPE 593D

## Solid Tantalum Chip Capacitors

### Commercial, Surface Mount

### for Switch Mode Power Supplies and Converters

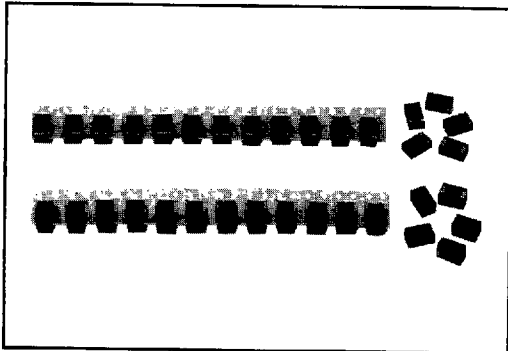

#### FEATURES

- Molded case available in two case codes
- Compatible with all popular "High Volume" automatic pick and place equipment
- 100% Repetitive Surge Current conditioned
- High Ripple Current carrying capability
- Low ESR, DF, DCL
- 12mm tape available per EIA-481-1 and reeling per IEC 286-3. 13" [330mm] standard; 7" [178mm] available.

#### PERFORMANCE/ELECTRICAL CHARACTERISTICS

**Operating Temperature:** - 55°C to + 85°C. (To + 125°C with voltage derating.)

**Capacitance Range:** 10µF to 330µF.

**Capacitance Tolerance:** ± 20%, ± 10% standard. ± 5% available as special.

**Voltage Rating:** 4 WVDC to 35 WVDC.

**Resistance to Solder Heat:** 260°C ± 5°C for 30 ± .5 seconds.

**Coefficient Thermal Expansion:** 75 x 10<sup>-6</sup> inch/inch/°C.

**Molded Body:** Semiconductor grade molding material.

**Compliant Terminals:** 60/40 SnPb finish, standard.

**Automatic Redundant Screening:** Capacitance, DF, DCL and ESR. (Data shipped with product on request.)

#### DIMENSIONAL CONFIGURATIONS [Numbers in brackets indicate millimeters]

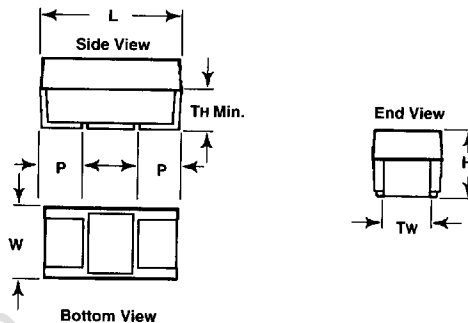

Note: Termination configuration at manufacturer's option

CASE CODE	EIA SIZE	L	W	H	P	Tw	TH (Min.)
D	7343	.287 ± .012 [7.3 ± .30]	.170 ± .012 [4.3 ± .30]	.110 ± .012 [2.8 ± .30]	.051 ± .012 [1.3 ± .30]	.095 ± .004 [2.4 ± .10]	.039 [1.0]
E	7343H	.287 ± .012 [7.3 ± .30]	.170 ± .012 [4.3 ± .30]	.158 ± .012 [4.0 ± .30]	.051 ± .012 [1.3 ± .30]	.095 ± .004 [2.4 ± .10]	.039 [1.0]

**TYPE 593D**

μF	6.3 V	10 V	16 V	20 V	25 V	35 V
10						D
15					D	E
22				D	D	E
33			D	D	E	
47			D	E		
68		D	E	E		
100	D	D	E			
150	E	E				
220	E	E*				
330	E*					

\* Ratings under evaluation.

Sprague® reserves the option to substitute units of higher voltage ratings and/or tighter capacitance tolerance.

CAPACITANCE (μF)	CASE CODE	PART NUMBER**	Max. DCL @ + 25°C (μA)	Max. DF @ + 25°C 120Hz (%)	Max. ESR @ + 25°C 100kHz (Ohms)	Max. RIPPLE 100kHz Irms (Amps)
<b>6.3 WVDC @ + 85°C, SURGE = 8 V ... 4 WVDC @ + 125°C, SURGE = 5 V</b>						
100	D	593D107X06R3D2W	4.8	6	0.100	1.22
150	E	593D157X06R3E2W	7.2	6	0.100	1.28
220	E	593D227X06R3E2W	10.6	6	0.100	1.28
330*	E	593D337X06R3E2W	15.8	6	0.100	1.28
<b>10 WVDC @ + 85°C, SURGE = 13 V ... 7 WVDC @ + 125°C, SURGE = 8 V</b>						
68	D	593D686X0010D2W	5.4	4	0.175	0.93
100	D	593D107X0010D2W	8.0	6	0.100	1.22
150	E	593D157X0010E2W	12.0	6	0.100	1.28
220*	E	593D227X0010E2W	17.6	6	0.100	1.28
<b>16 WVDC @ + 85°C, SURGE = 20 V ... 10 WVDC @ + 125°C, SURGE = 12 V</b>						
33	D	593D336X0016D2W	4.2	4	0.225	0.82
47	D	593D476X0016D2W	6.0	4	0.175	0.93
68	E	593D686X0016E2W	8.7	4	0.150	1.05
100	E	593D107X0016E2W	12.8	6	0.150	1.05
<b>20 WVDC @ + 85°C, SURGE = 26 V ... 13 WVDC @ + 125°C, SURGE = 16 V</b>						
22	D	593D226X0020D2W	3.5	4	0.225	0.82
33	D	593D336X0020D2W	5.3	4	0.225	0.82
47	E	593D476X0020E2W	7.5	4	0.200	0.91
68	E	593D686X0020E2W	10.9	4	0.200	0.91
<b>25 WVDC @ + 85°C, SURGE = 32 V ... 17 WVDC @ + 125°C, SURGE = 20 V</b>						
15	D	593D156X0025D2W	3.0	4	0.275	0.74
22	D	593D226X0025D2W	4.4	4	0.250	0.77
33	E	593D336X0025E2W	6.6	4	0.225	0.86
<b>35 WVDC @ + 85°C, SURGE = 46 V ... 23 WVDC @ + 125°C, SURGE = 28 V</b>						
10	D	593D106X0035D2W	2.8	4	0.300	0.71
15	E	593D156X0035E2W	4.2	4	0.275	0.77
22	E	593D226X0035E2W	6.2	4	0.275	0.77

\*\* Part Numbers shown for units with ± 20% capacitance tolerance. For ± 10% tolerance, change "X0" to "X9". Standard packaging is 13" [330] reel with cathode nearest the sprocket holes.

TYPE 593D

TYPICAL CURVES @ + 25°C, IMPEDANCE AND ESR vs FREQUENCY, TYPICAL RESPONSE

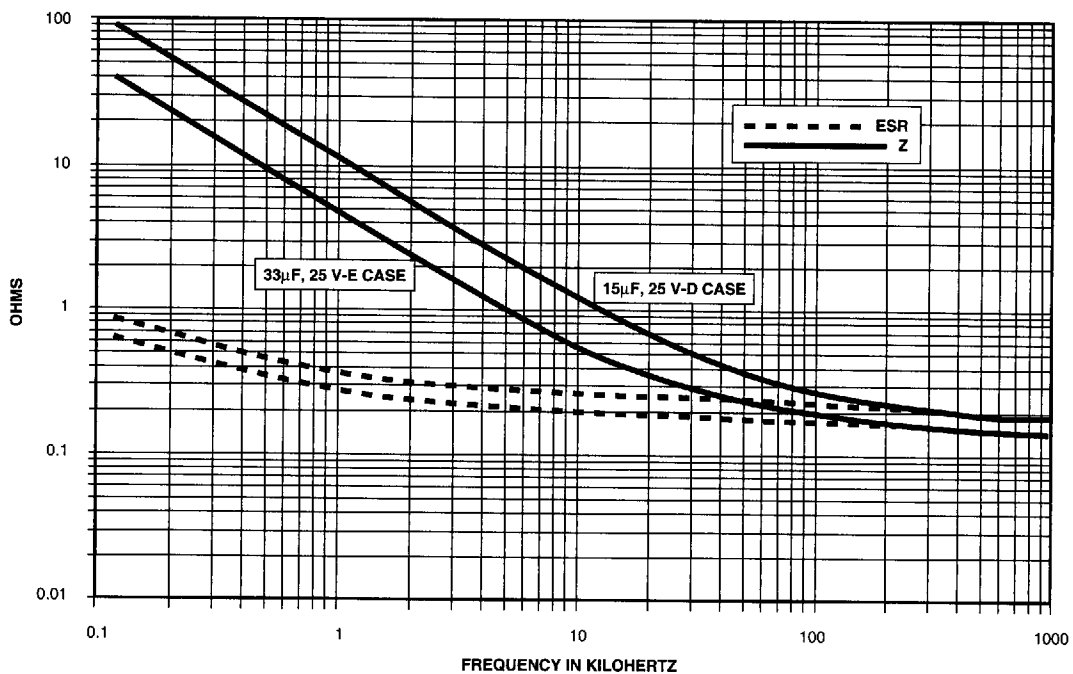
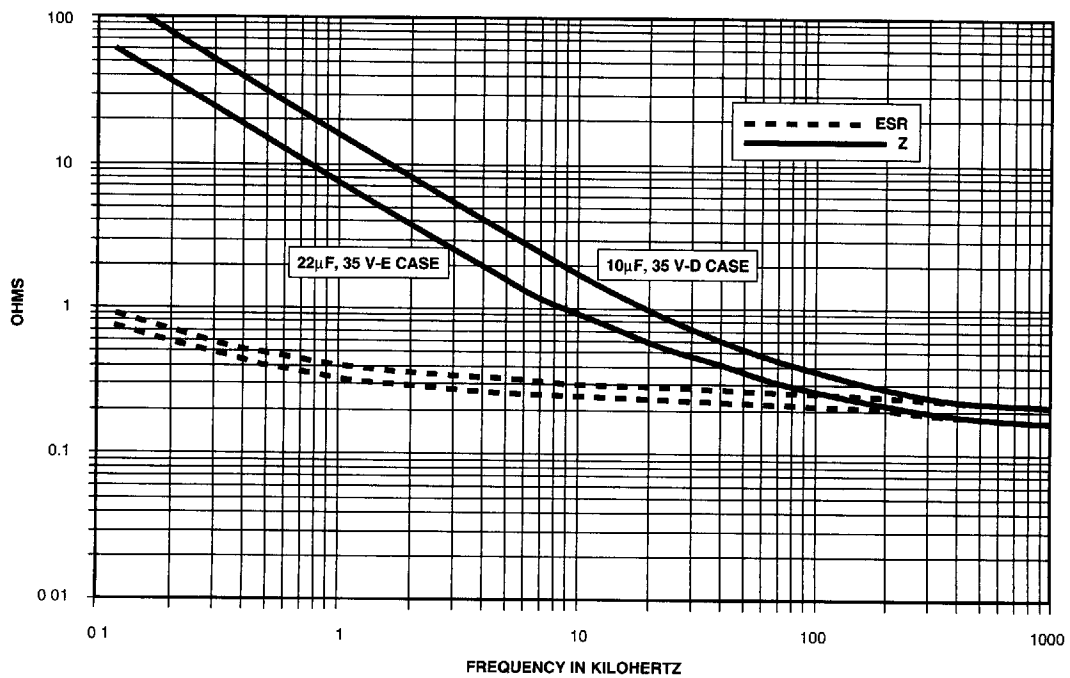

TYPE 593D

20°C IMPEDANCE AND ESR vs FREQUENCY, TYPICAL RESPONSE

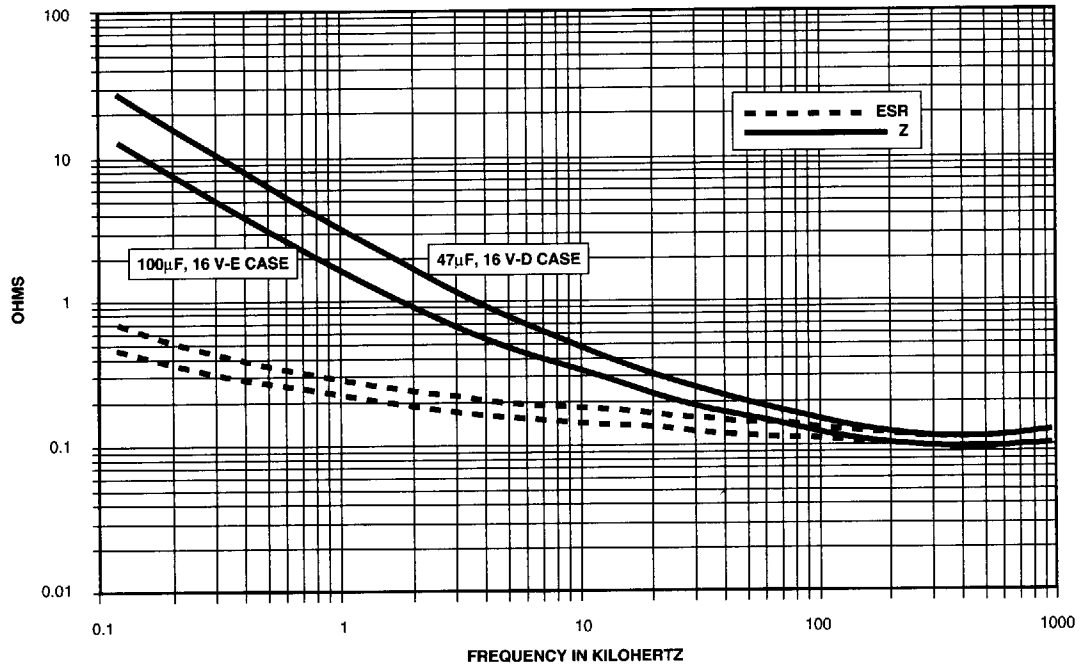
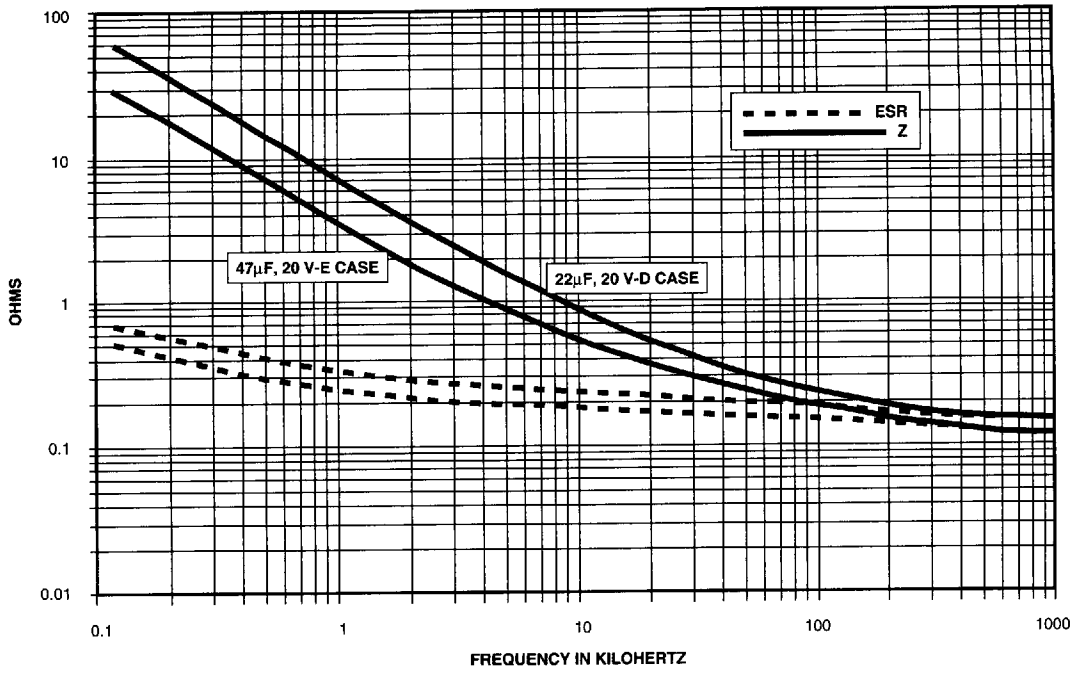

**TYPE 593D**

**PERFORMANCE CHARACTERISTICS**

- 1. **Operating Temperature:** Capacitors are designed to operate over the temperature range of - 55°C to + 85°C.
- 1.1 Capacitors may be operated to + 125°C with voltage derating to two-thirds the + 85°C rating.

+ 85°C Rating		+ 125°C Rating	
Working Voltage (V)	Surge Voltage (V)	Working Voltage (V)	Surge Voltage (V)
6.3	8.0	4.0	5.0
10.0	13.0	7.0	8.0
16.0	20.0	10.0	12.0
20.0	26.0	13.0	16.0
25.0	32.0	17.0	20.0
35.0	46.0	23.0	28.0

- 2. **DC Working Voltage:** The DC working voltage is the maximum operating voltage for continuous duty at the rated temperature.
- 3. **Surge Voltage:** The surge DC rating is the maximum voltage to which the capacitors may be subjected under any conditions, including transients and peak ripple at the highest line voltage.
- 3.1 **Surge Voltage Test:** Capacitors shall withstand the surge voltage applied in series with a 33 ohm ± 5% resistor at the rate of one-half minute on, one-half minute off, at + 85°C, for 1000 successive test cycles.
- 3.2 Following the surge voltage test, the dissipation factor and the leakage current shall meet the initial requirements; the capacitance shall not have changed more than ± 10%.
- 4. **Capacitance Tolerance:** The capacitance of all capacitors shall be within the specified tolerance limits of the nominal rating.
- 4.1 Capacitance measurements shall be made by means of a polarized capacitance bridge. The polarizing voltage shall be of such magnitude that there shall be no reversal of polarity due to the AC component. The maximum voltage applied to capacitors during measurement shall be 2 volts rms at 120Hz at + 25°C. If the AC voltage applied is less than one-half volt rms, no DC bias is required. Accuracy of the bridge shall be within ± 2%.
- 5. **Capacitance Change With Temperature:** The capacitance change with temperature shall not exceed the following percentage of the capacitance measured at + 25°C:

- 55°C	+ 85°C	+ 125°C
- 10%	+ 10%	+ 12%

- 6. **Dissipation Factor:** The dissipation factor, determined from the expression  $2\pi fRC$ , shall not exceed values listed in the Standard Ratings Table.

- 6.1 Measurements shall be made by the bridge method at, or referred to, a frequency of 120Hz and a temperature of + 25°C.
- 7. **Leakage Current:** Capacitors shall be stabilized at the rated temperature for 30 minutes. Rated voltage shall be applied to capacitors for 5 minutes using a steady source of power (such as a regulated power supply) with a 1000 ohm resistor connected in series with the capacitor under test to limit the charging current. Leakage current shall then be measured.

*Note that leakage current varies with applied voltage. See graph below for the appropriate adjustment factor.*

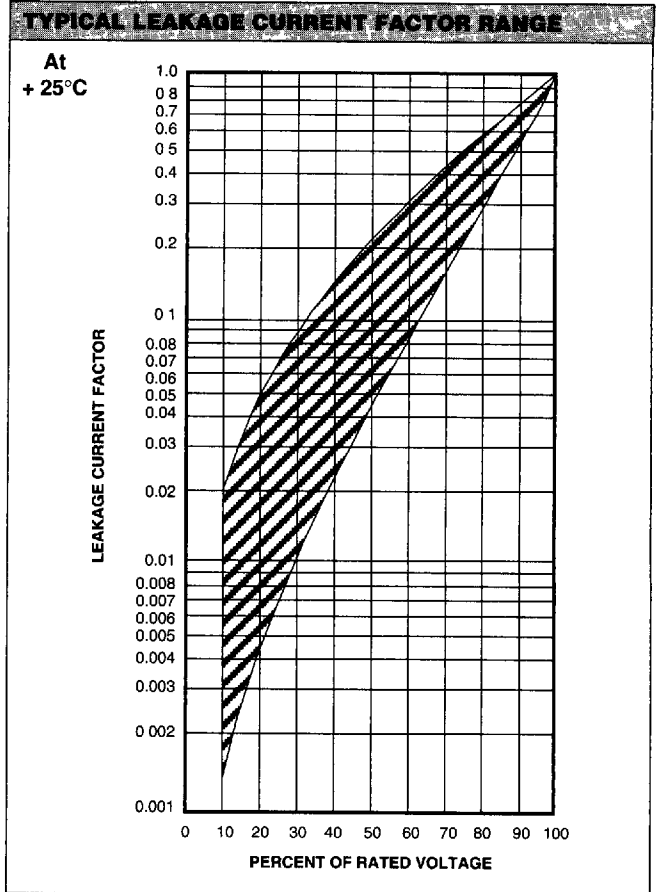

- 7.1 **At + 25°C,** the leakage current shall not exceed the value listed in the Standard Ratings Table.
- 7.2 **At + 85°C,** the leakage current shall not exceed 10 times the value listed in the Standard Ratings Table.
- 7.3 **At + 125°C,** the leakage current shall not exceed 12 times the value listed in the Standard Ratings Table.
- 8. **Life Test:** Capacitors shall withstand rated DC voltage applied at + 85°C or two-thirds rated voltage applied at + 125°C for 2000 hours.
- 8.1 Following the life test, the dissipation factor shall meet the initial requirement; the capacitance change shall not exceed ± 10%; the leakage current shall not exceed 125% of the initial requirement.

**TYPE 593D****PERFORMANCE CHARACTERISTICS (Continued)**

9. **Vibration Tests:** Capacitors shall be subject to vibration tests in accordance with the following criteria.
- 9.1 Capacitors shall be secured for test by means of a rigid mounting using suitable brackets.
- 9.2 **Low Frequency Vibration:** Vibration shall consist of a simple harmonic motion having an amplitude of 0.03" [0.76] and a maximum total excursion of 0.06" [1.52], in a direction perpendicular to the major axis of the capacitors.
- 9.2.1 Vibration frequency shall be varied uniformly between the approximate limits of 10Hz to 55Hz during a period of approximately one minute, continuously for 1.5 hours.
- 9.2.2 An oscilloscope or other comparable means shall be used in determining electrical intermittency during the final 30 minutes of the test. The AC voltage applied shall not exceed 2 volts rms.
- 9.2.3 Electrical test shall show no evidence of intermittent contacts, open circuits or short circuits during these tests.
- 9.2.4 Following the low frequency vibration test, capacitors shall meet the original requirements for capacitance, dissipation factor and leakage current.
- 9.3 **High Frequency Vibration:** Vibration shall consist of a simple harmonic motion having an amplitude of 0.06" [1.52]  $\pm$  10% maximum total excursion or 20 g peak whichever is less.
- 9.3.1 Vibration frequency shall be varied logarithmically from 50Hz to 2000Hz and return to 50Hz during a cycle period of 20 minutes.
- 9.3.2 The vibration shall be applied for 4 hours in each of 2 directions, parallel and perpendicular to the major axis of the capacitors.
- 9.3.3 Rated DC voltage shall be applied during the vibration cycling.
- 9.3.4 An oscilloscope or other comparable means shall be used in determining electrical intermittency during the last cycle. The AC voltage applied shall not exceed 2 volts rms.
- 9.3.5 Electrical tests shall show no evidence of intermittent contacts, open circuits or short circuits during these tests.
- 9.3.6 There shall be no mechanical damage to these capacitors as a result of these tests.
- 9.3.7 Following the high frequency vibration test, capacitors shall meet the original limits for capacitance, dissipation factor and leakage current.
10. **Acceleration Test:**
- 10.1 Capacitors shall be rigidly mounted by means of suitable brackets.
- 10.2 Capacitors shall be subjected to a constant acceleration of 100 g for a period of 10 seconds in each of 2 mutually perpendicular planes.
- 10.2.1 The direction of motion shall be parallel to and perpendicular to the longitudinal axis of the capacitors.
- 10.3 Rated DC voltage shall be applied during acceleration test.
- 10.3.1 An oscilloscope or other comparable means shall be used in determining electrical intermittency during test. The AC voltage applied shall not exceed 2 volts rms.
- 10.4 Electrical tests shall show no evidence of intermittent contacts, open circuits or short circuits during these tests.
- 10.5 There shall be no mechanical damage to these capacitors as a result of these tests.
- 10.6 Following the acceleration test, capacitors shall meet the original limits for capacitance, dissipation factor and leakage current.
11. **Shock Test:**
- 11.1 Capacitors shall be rigidly mounted by means of suitable brackets. The test load shall be distributed uniformly on the test platform to minimize the effects of unbalanced loads.
- 11.1.1 Test equipment shall be adjusted to produce a shock of 100 g peak with the duration of 6 mS and a sawtooth waveform at a velocity change of 9.7 ft./sec.
- 11.2 Capacitors shall be subjected to 3 shocks applied in each of 3 directions corresponding to the 3 mutually perpendicular axes of the capacitors.
- 11.3 Rated DC voltage shall be applied during test.
- 11.3.1 An oscilloscope or other comparable means shall be used in determining electrical intermittency during tests. The replacement voltage applied shall not exceed 2 volts rms.
- 11.4 Electrical tests shall show no evidence of intermittent contacts, open circuits or short circuits during these tests.
- 11.5 There shall be no mechanical damage to these capacitors as a result of these tests.
- 11.6 Following the shock test, capacitors shall meet the original limits for capacitance, dissipation factor and leakage current.
12. **Moisture Resistance:**
- 12.1 Capacitors shall be subjected to temperature cycling at 90% to 95% relative humidity, from + 25°C to + 65°C to + 25°C (+ 10°C, - 2°C) over a period of 8 hours per cycle for 1000 hours.
- 12.2 Following the moisture resistance test, the leakage current and dissipation factor shall meet the initial requirements; the change in capacitance shall not exceed  $\pm$  10%.
13. **Humidity Test:**
- 13.1 Capacitors shall withstand exposure to 85% relative humidity at full rated voltage; at + 85°C for 1000 hours.
- 13.2 Following the humidity test, the leakage current shall not exceed 2 times the initial requirement; the dissipation factor shall not exceed 1.5 times the initial requirement; the change in capacitance shall not exceed  $\pm$  10%.

**TYPE 593D**

**PERFORMANCE CHARACTERISTICS (Continued)**

**14. Thermal Shock:**

- 14.1 Capacitors shall be conditioned prior to temperature cycling for 15 minutes at + 25°C, at less than 50% relative humidity and a barometric pressure at 28 to 31 inches.
- 14.2 Capacitors shall be subjected to thermal shock in a cycle of exposure to ambient air at - 55°C (+ 0°C, - 5°C) for 30 minutes, then + 25°C (+ 10°C, - 5°C) for 5 minutes, then + 125°C (+ 3°C, - 0°C) for 30 minutes, then + 25°C (+ 10°C, - 5°C) for 5 minutes for 5 cycles.
- 14.3 Capacitors shall show no evidence of harmful or extensive corrosion, obliteration of marking or other visible damage.
- 14.4 Following the thermal shock test, capacitors shall meet the original requirements for leakage current and dissipation factor; capacitance change shall not exceed ± 5% of the original measured value.

**15. Soldering Compatibility:**

- 15.1 **Solder Dip:** Capacitors will withstand two cycles of a dip in non-activated rosin flux, followed by full immersion in 60/40 tin lead solder for 5 seconds at + 245°C.

- 15.1.1 **Capacitance:** DC leakage and dissipation factor shall remain within the initial requirements.
- 15.2 **Solder Heat:** Capacitors will withstand exposure to + 260°C + 5°C for 30 ± 0.5 seconds.
- 15.3 **Solderability:** Capacitors will meet the solderability requirements of MIL-STD-202, Method 208.
- 16. **Marking:** Capacitor marking will include an anode (+) polarity band, capacitance in microfarads and the voltage rating at + 85°C. The Sprague® trademark will be included.
- 16.1 Units rated at 6.3 V shall be marked 6 V.
- 16.2 A manufacturing date code is marked on both case codes. Call the factory for further explanation.

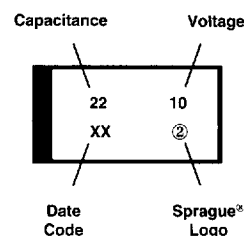

**GUIDE TO APPLICATION**

- 1. **A-C Ripple Current:** The maximum allowable ripple current shall be determined from the formula:

$$I_{rms} = \sqrt{\frac{P}{R_{ESR}}}$$

where,

P = Power Dissipation in Watts @ + 25°C as given in the table in Paragraph Number 5 (Power Dissipation).

R<sub>ESR</sub> = The capacitor Equivalent Series Resistance at the specified frequency.

- 2. **A-C Ripple Voltage:** The maximum allowable ripple voltage shall be determined from the formula:

$$V_{rms} = Z \sqrt{\frac{P}{R_{ESR}}}$$

or, from the formula:

$$V_{rms} = I_{rms} \times Z$$

where,

P = Power Dissipation in Watts @ + 25°C as given in the table in Paragraph Number 5 (Power Dissipation).

R<sub>ESR</sub> = The capacitor Equivalent Series Resistance at the specified frequency.

Z = The capacitor Impedance at the specified frequency.

- 2.1 The sum of the peak AC voltage plus the DC voltage shall not exceed the DC voltage rating of the capacitor.
- 2.2 The sum of the negative peak AC voltage plus the applied DC voltage shall not allow a voltage reversal exceeding 10% of the DC working voltage at + 25°C.

- 3. **Reverse Voltage:** These capacitors are capable of withstanding peak voltages in the reverse direction equal to 10% of the DC rating at + 25°C, 5% of the DC rating at + 85°C and 1% of the DC rating at + 125°C.
- 4. **Temperature Derating:** If these capacitors are to be operated at temperatures above + 25°C, the permissible rms ripple current or voltage shall be calculated using the derating factors as shown:

Temperature	Derating Factor
+ 25°C	1.0
+ 55°C	0.9
+ 85°C	0.8
+ 125°C	0.4

- 5. **Power Dissipation:** Power dissipation will be affected by the heat sinking capability of the mounting surface. Non-sinusoidal ripple current may produce heating effects which differ from those shown. It is important that the equivalent I<sub>rms</sub> value be established when calculating permissible operating levels. (Power Dissipation calculated using + 25°C temperature rise.)

Case Code	Maximum Permissible Power Dissipation @ + 25°C (Watts) in free air
D	0.150
E	0.165

- 6. **Printed Circuit Board Materials:** The 593D is compatible with commonly used printed circuit board materials (alumina substrates, FR4, FR5, G10, PTFE- fluorocarbon and porcelainized steel).

**TYPE 593D**

**GUIDE TO APPLICATION (Continued)**

**7. Attachment:**

**7.1 Solder Paste:** The recommended thickness of the solder paste after application is .007" ± .001" [.178 ± .025]. Care should be exercised in selecting the solder paste. The metal purity should be as high as practical. The flux (in the paste) must be active enough to remove the oxides formed on the metallization prior to the exposure to soldering heat. In practice this can be aided by extending the solder preheat time at temperatures below the liquidous state of the solder.

**7.2 Soldering:** Capacitors can be attached by conventional soldering techniques - vapor phase, infrared reflow, wave soldering and hot plate methods. The Soldering Profile chart shows maximum recommended time/temperature

conditions for soldering. Attachment with a soldering iron is not recommended due to the difficulty of controlling temperature and time at temperature.

**8. Cleaning (Flux Removal) After Soldering:** The 593D is compatible with all commonly used solvents such as TES, TMS, Prelete, Chlorethane, Terpene and aqueous cleaning media. However, CFC/ODS products are not used in the production of these devices and are not recommended. Solvents containing methylene chloride or other epoxy solvents should be avoided since these will attack the epoxy encapsulation material.

**8.1** When using ultrasonic cleaning, the board may resonate if the output power is too high. This vibration can cause cracking or a decrease in the adherence of the termination.

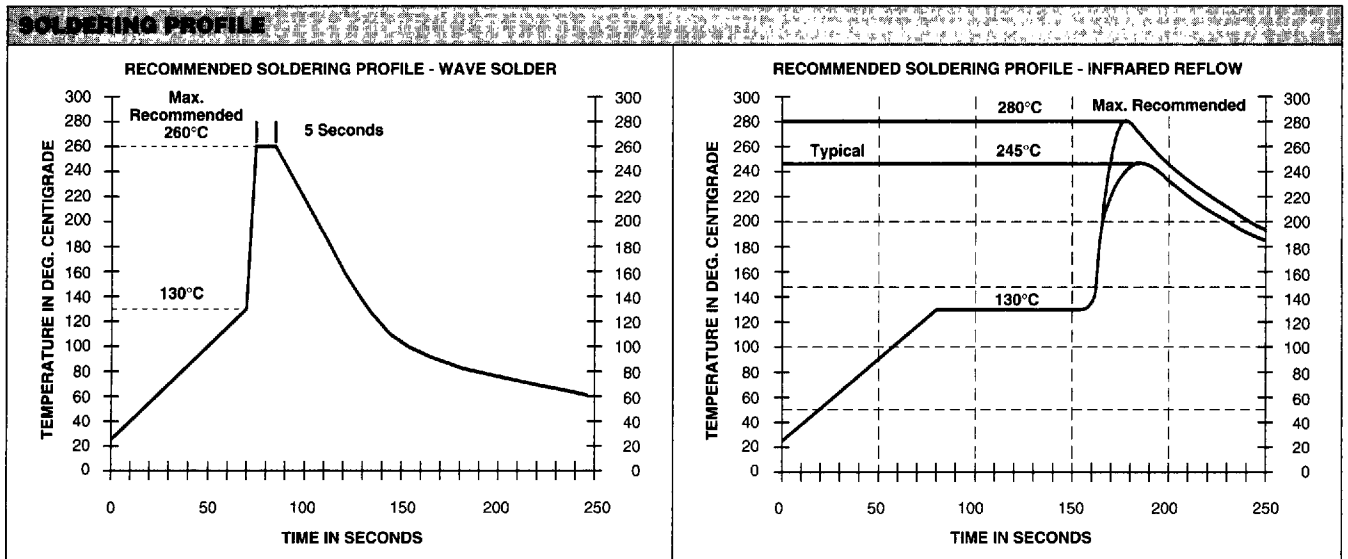

**9. Recommended Mounting Pad Geometries:** Proper mounting pad geometries are essential for successful solder connections. These dimensions are highly process sensitive and should be designed to minimize component rework due to unacceptable solder joints. The dimensional configurations shown are the recommended pad geometries for both wave and reflow soldering techniques. These dimensions are intended to be a starting point for circuit board designers and may be fine tuned if necessary based upon the peculiarities of the soldering process and/or circuit board design.

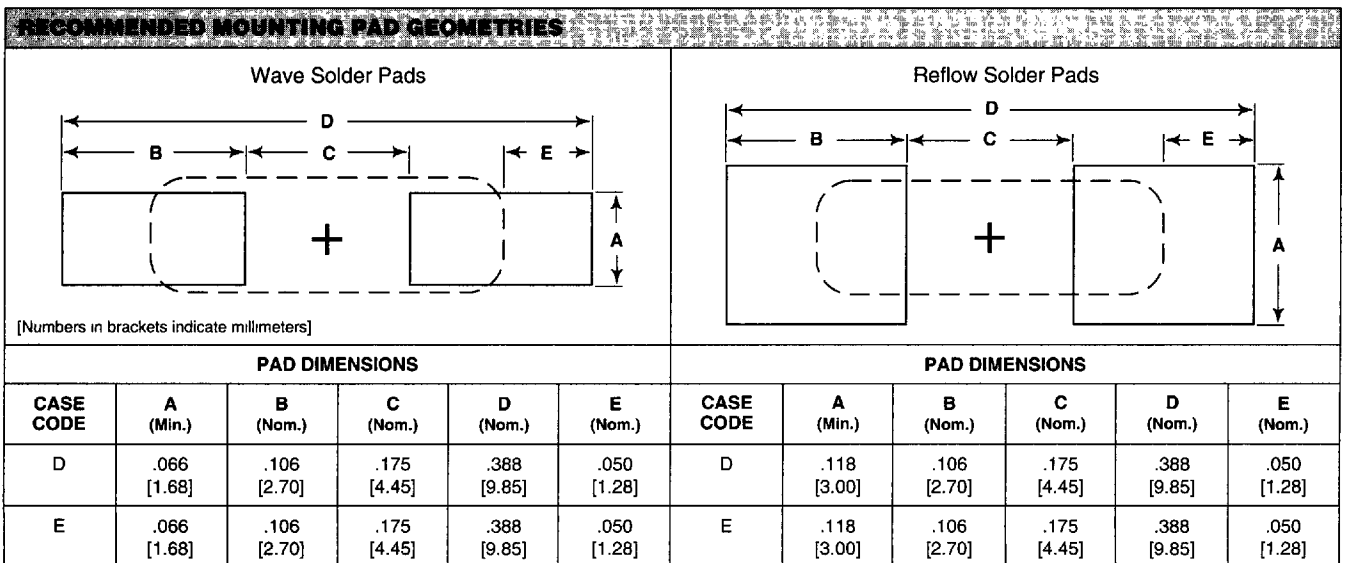



**TYPE 593D**

**HOW TO ORDER**

<b>593D</b> TYPE	<b>107</b> CAPACITANCE	<b>X0</b> CAPACITANCE TOLERANCE	<b>010</b> DC VOLTAGE RATING AT + 85°C	<b>D</b> CASE CODE	<b>2</b> TERMINATION	<b>W</b> REEL SIZE AND PACKAGING
	This is expressed in picofarads. The first two digits are the significant figures. The third is the number of zeros to follow.	X0 = ± 20% X9 = ± 10% X5 = ± 5% Special Order.	This is expressed in volts. To complete the three-digit block, zeros precede the voltage rating. A decimal point is indicated by an "R" (6R3 = 6.3 volts).	See Ratings and Case Codes Table.	2 = Solderable coating. Standard.	T = 7" [178] reel, cathode nearest sprocket hole. V = 7" [178] reel, anode nearest sprocket hole. W = 13" [330] reel, cathode nearest sprocket hole. (Preferred.) X = 13" [330] reel, anode nearest sprocket hole.

**TAPE AND REEL PACKAGING**

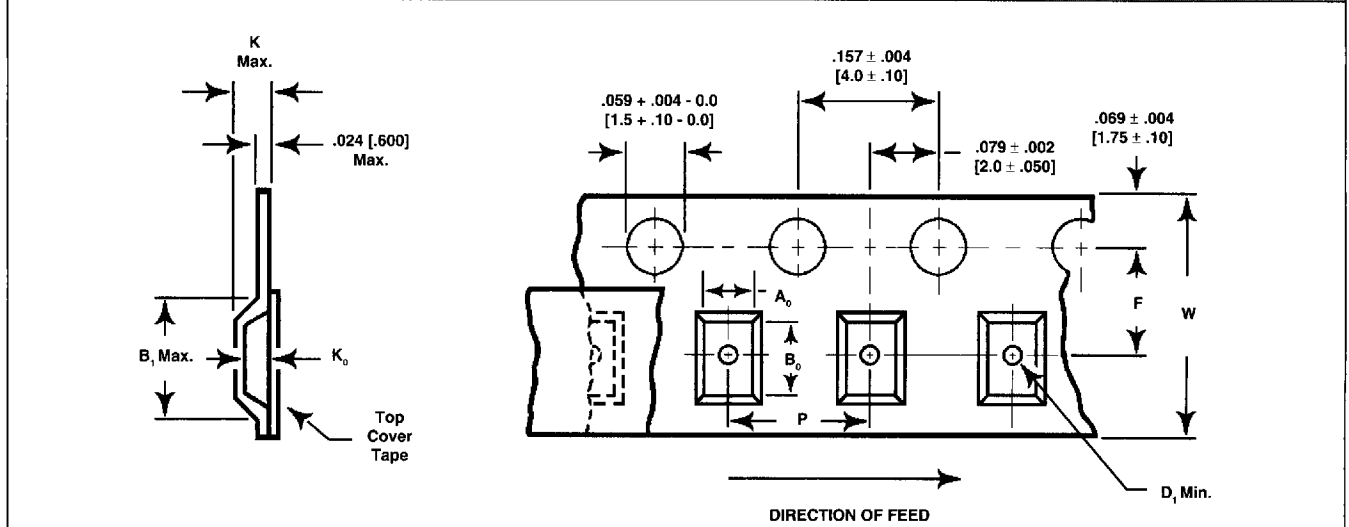

[Numbers in brackets indicate millimeters]

TAPE SIZE	B <sub>1</sub> (Max.)	D <sub>1</sub> (Min.)	F	K (Max.)	P	W	A <sub>0</sub> B <sub>0</sub> K <sub>0</sub>
12mm	.323 [8.2]	.059 [1.5]	.217 ± .002 [5.5 ± .05]	.177 [4.5]	.315 ± .004 [8.0 ± .10]	.472 ± .012 [12.0 ± .30]	<b>Notes:</b> A <sub>0</sub> B <sub>0</sub> K <sub>0</sub> are determined by component size. The clearance between the component and the cavity must be within .002" [.05] minimum to .020" [.50] maximum for 8mm tape and .002" [.05] minimum to .026" [.65] maximum for 12mm tape.

**Tape and Reel Specifications:** All case codes are available on plastic embossed tape per EIA-481-1. Tape reeling per IEC 286-3 is also available. Standard reel diameter is 13" [330]. 7" [178] reels are available.

The most efficient packaging quantities are full reel increments on a given reel diameter. The quantities shown allow for the sealed empty pockets required to be in conformance with EIA-481-1. Reel size and packaging orientation must be specified in the Sprague® part number.

Case Code	Tape Width	Component Pitch	Units Per Reel	
			7" [178] Reel	13" [330] Reel
D	12mm	8mm	500	2500
E	12mm	8mm	400	1500