

FEATURES

- HIGH RELIABILITY FOR LOW COST
- LOW PROFILE - 2.5 MM MAX. PACKAGE HEIGHT
- EXTENDED TEMPERATURE RANGE TO -40/+125°C
- EXCELLENT CLOCK SIGNAL GENERATOR FOR CPU'S
- QUALIFIED FOR QUOTMOTIVE APPLICATIONS



PETERMANN

TECHNIK

Time & Frequency Components

SERIES		HC-49/US		
NUMBER OF LEADS	STANDARD	2 LEADS		
	OPTION	3 LEADS		
PACKAGE HEIGHT	STANDARD	3.5 MM		
	OPTION	2.5 MM		
FREQUENCY		3.579 ~ 40.0 MHz	20.0 ~ 40.5504 MHz	24.0 ~ 70.0 MHz
MODE OF VIBRATION		AT-FUNDAMENTAL	BT-FUNDAMENTAL	3rd OVERTONE
RESONANCE RESISTANCE		180 ~ 25 Ω MAX.	40 Ω MAX.	120 ~ 80 Ω MAX.
FREQUENCY TOLERANCE AT 25°C		+/-10 PPM ~ +/-50 PPM		
TEMPERATURE RANGE		0/+50°C ~ -40/+125°C		
TEMPERATURE STABILITY	+/-10 PPM	0/+50°C / -10/+60°C / 0/+70°C		
	+/-15 PPM	0/+50°C / -10/+60°C / 0/+70°C / -20/+70°C		
	+/-20 PPM	0/+50°C / -10/+60°C / 0/+70°C / -20/+70°C / -40/+85°C		
	+/-30 PPM	0/+50°C / -10/+60°C / 0/+70°C / -20/+70°C / -40/+85°C		
	+/-50 PPM	0/+50°C / -10/+60°C / 0/+70°C / -20/+70°C / -40/+85°C / -40/+125°C		
	+/-100 PPM	0/+50°C / -10/+60°C / 0/+70°C / -20/+70°C / -40/+85°C / -40/+125°C		
LOAD CAPACITANCE		8 ~ 50 PF OR SERIES		
SHUNT CAPACITANCE		7 PF MAX.		
DRIVE LEVEL		100 µW typical (0.01 mW ~ 2 mW possible)		
AGING		+3 ~ +5 PPM PER YEAR		
INSULATION RESISTANCE		>500 MΩ DC/100V +/-10%		
STORAGE TEMPERATURE		-55/+125°C		
DELIVERY FORM	STANDARD	BULKS		
	OPTION	TAPE AND REEL (1.000 PCS PER REEL)		
INSULATOR	STANDARD	WITHOUT INSULATOR		
	OPTION	WITH INSULATOR		
OTHER PARAMETERS ARE AVAILABLE ON REQUEST / CREATE HERE YOUR SPECIFICATION				

PART NUMBERING SYSTEM

EXAMPLE	HC-49/US-2.5 27.000 MHz 30/50/-40+125/20pF/T/I
----------------	--

TYPE	HC-49/US FOR TYPE WITH 2 LEADS
	HC-49/3US FOR TYPE WITH 3 LEADS
PACKAGE HEIGHT	BLANK FOR 3.5 MM
	2.5 FOR 2.5 MM
FREQUENCY	IN MHZ
FREQUENCY TOLERANCE AT 25°C	REQUIRED VALUE
TEMPERATURE STABILITY	REQUIRED VALUE
TEMPERATURE RANGE	REQUIRED VALUE
LOAD CAPACITANCE	REQUIRED VALUE
DELIVERY FORM	BLANK FOR BULKS
	T FOR TAPE AND REEL
INSULATOR	BLANK = WITHOUT INSULATOR
	I = WITH INSULATOR

OUTLINE DRAWING OF HC-49/US

OUTLINE DRAWING OF HC-49/3US

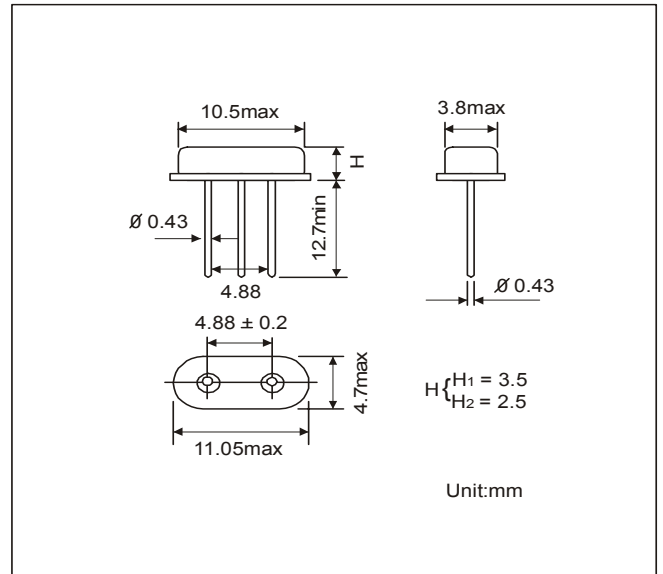
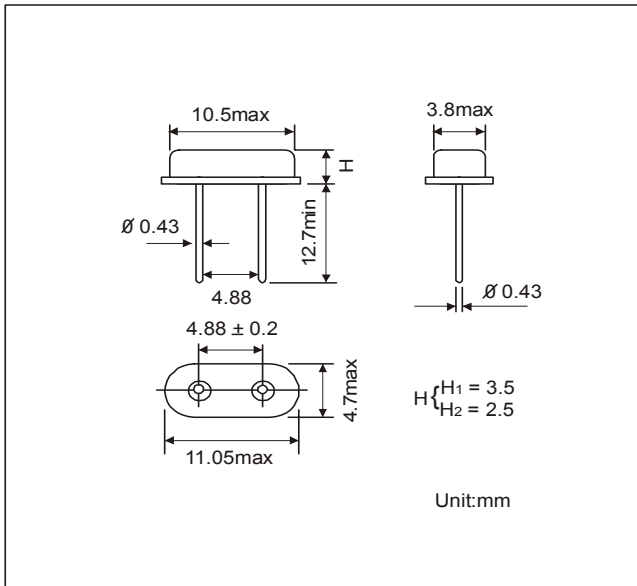

REEL SPECIFICATION

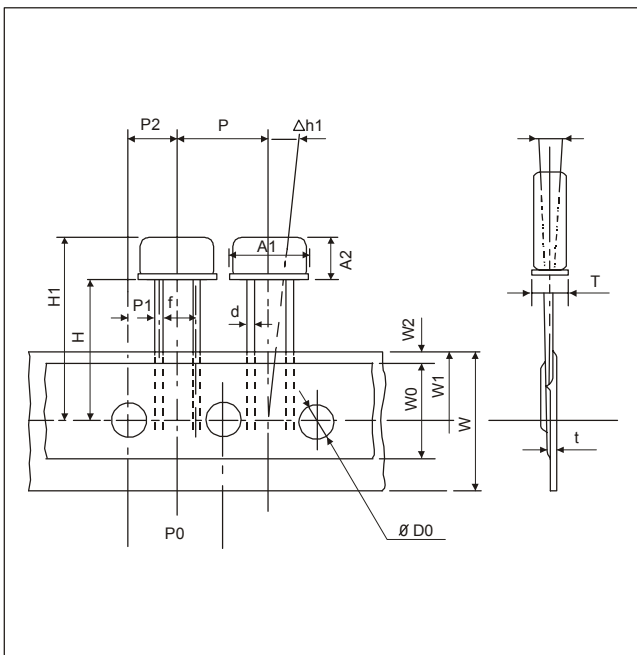

Description	Symbol	Dimensions
Outside Diameter of Part	A1xA2	11.1x3.5
Thickness of Part	T	5.0max
Lead Wire Diameter	d	Ø0.43 ^{+0.05} / _{-0.02}
Interval Spacing of Part	P	12.7±1.0
Pitch fo Leading Hole	P0	12.7±1.0
	P1	3.85±0.7
Tolerance of Leading Hole	P2	6.35±1.0
	F	5.0 ^{+0.5} / _{-0.2}
Lead Pitch	F	5.0 ^{+0.5} / _{-0.2}
Inclination	Δ h	0±1.0
Tape Width	W	18.2±0.2
Adhesive Tape Width	W0	13.0 ^{+0.8} / _{-0.2}
Tolerance of Leading Hole(Vertical)	W1	9.0±0.5
Tolerance of Cover Tape	W2	2.0max
Bottom Surface Position of Part	H	20.5±0.5
Top Surface Position of Part	H1	24.0max
Hole Diameter	D0	Ø4.0±0.2
Tape Thickness	t	0.7±0.1
Inclination	Δ h1	0±1.0

Unit:mm