

**Diagonal 6mm (Type 1/3) CCD Image Sensor for NTSC Color Video Camera**

**Description**

The ICX058CK is an interline CCD solid-state image sensor suitable for NTSC color video cameras. Compared with the current product ICX058AK, sensitivity is improved drastically through the adoption of Super HAD CCD technology. High resolution is achieved through the use of Ye, Cy, Mg, and G complementary color mosaic filters.

This chip features a field period readout system and an electronic shutter with variable charge-storage time.

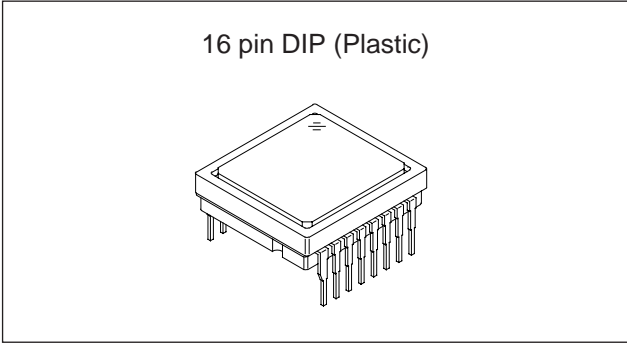

**Features**

- High sensitivity (+3dB at F5.6, +4dB at F1.2 compared with ICX058AK)
- High resolution, low smear and low dark current
- Excellent antiblooming characteristics
- Continuous variable-speed shutter
- Ye, Cy, Mg, and G complementary color mosaic filters on chip
- Horizontal register:           5V drive
- Reset gate:                    5V drive

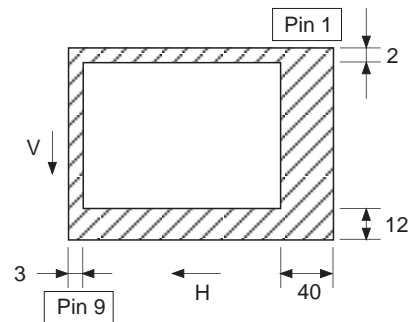

**Optical black position  
(Top View)**

**Device Structure**

- Interline CCD image sensor
- Image size:                    Diagonal 6mm (Type 1/3)
- Number of effective pixels:   768 (H) × 494 (V) approx. 380K pixels
- Number of total pixels:       811 (H) × 508 (V) approx. 410K pixels
- Chip size:                     6.00mm (H) × 4.96mm (V)
- Unit cell size:                6.35μm (H) × 7.40μm (V)
- Optical black:                 Horizontal (H) direction: Front 3 pixels, rear 40 pixels  
  Vertical (V) direction:    Front 12 pixels, rear 2 pixels
- Number of dummy bits:       Horizontal 22  
  Vertical 1 (even field only)
- Substrate material:           Silicon

**Super HAD CCD®**

\*Super HAD CCD is a registered trademark of Sony Corporation. Super HAD CCD is a CCD that drastically improves sensitivity by introducing newly developed semiconductor technology by Sony Corporation into Sony's high-performance HAD (Hole-Accumulation Diode) sensor.

Sony reserves the right to change products and specifications without prior notice. This information does not convey any license by any implication or otherwise under any patents or other right. Application circuits shown, if any, are typical examples illustrating the operation of the devices. Sony cannot assume responsibility for any problems arising out of the use of these circuits.

**Block Diagram and Pin Configuration**

(Top View)

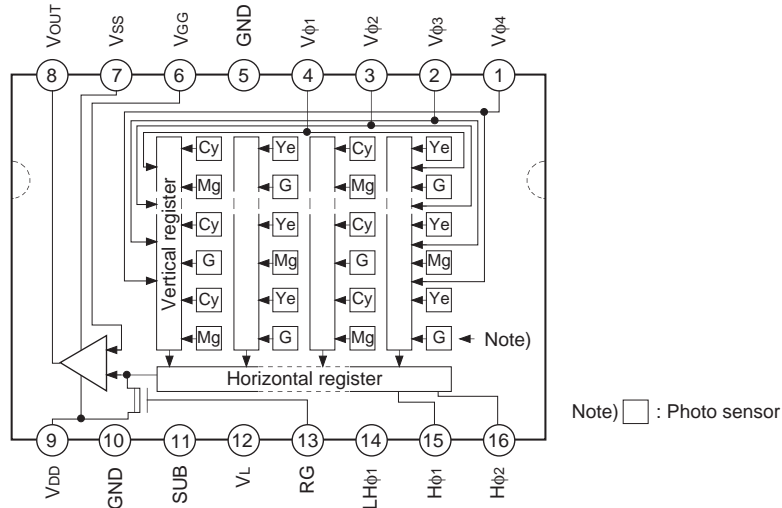

**Pin Description**

Pin No.	Symbol	Description	Pin No.	Symbol	Description
1	Vφ4	Vertical register transfer clock	9	VDD	Output amplifier drain supply
2	Vφ3	Vertical register transfer clock	10	GND	GND
3	Vφ2	Vertical register transfer clock	11	SUB	Substrate (Overflow drain)
4	Vφ1	Vertical register transfer clock	12	VL	Protective transistor bias
5	GND	GND	13	RG	Reset gate clock
6	VGG	Output amplifier gate bias	14	LHφ1	Horizontal register final stage transfer clock
7	VSS	Output amplifier source	15	Hφ1	Horizontal register transfer clock
8	VOUT	Signal output	16	Hφ2	Horizontal register transfer clock

**Absolute Maximum Ratings**

Item		Ratings	Unit	Remarks
Substrate voltage SUB – GND		-0.3 to +55	V	
Supply voltage	VDD, VOUT, VSS – GND	-0.3 to +18	V	
	VDD, VOUT, VSS – SUB	-55 to +10	V	
Vertical clock input voltage	Vφ1, Vφ2, Vφ3, Vφ4 – GND	-15 to +20	V	
	Vφ1, Vφ2, Vφ3, Vφ4 – SUB	to +10	V	
Voltage difference between vertical clock input pins		to +15	V	*1
Voltage difference between horizontal clock input pins		to +17	V	
Hφ1, Hφ2 – Vφ4		-17 to +17	V	
Hφ1, Hφ2, LHφ1, RG, VGG – GND		-10 to +15	V	
Hφ1, Hφ2, LHφ1, RG, VGG – SUB		-55 to +10	V	
VL – SUB		-65 to +0.3	V	
Vφ1, Vφ2, Vφ3, Vφ4, VDD, VOUT – VL		-0.3 to +30	V	
RG – VL		-0.3 to +24	V	
VGG, VSS, Hφ1, Hφ2, LHφ1 – VL		-0.3 to +20	V	
Storage temperature		-30 to +80	°C	
Operating temperature		-10 to +60	°C	

\*1 +27V (Max.) when clock width < 10μs, clock duty factor < 0.1%.

## Bias Conditions

Item	Symbol	Min.	Typ.	Max.	Unit	Remarks
Output amplifier drain voltage	$V_{DD}$	14.55	15.0	15.45	V	
Output amplifier gate voltage	$V_{GG}$	3.8	4.2	4.65	V	
Output amplifier source	$V_{SS}$	Grounded with 820 $\Omega$ resistor				$\pm 5\%$
Substrate voltage adjustment range	$V_{SUB}$	9.0		18.5	V	*1
Fluctuation range after substrate voltage adjustment	$\Delta V_{SUB}$	-3		+3	%	
Reset gate clock voltage adjustment range	$V_{RGL}$	1.0		4.0	V	*1, *6
Fluctuation range after reset gate clock voltage adjustment	$\Delta V_{RGL}$	-3		+3	%	
Protective transistor bias	$V_L$	*2				

## DC Characteristics

Item	Symbol	Min.	Typ.	Max.	Unit	Remarks
Output amplifier drain current	$I_{DD}$		5		mA	
Input current	$I_{IN1}$			1	$\mu\text{A}$	*3
Input current	$I_{IN2}$			10	$\mu\text{A}$	*4

\*1 Indications of substrate voltage ( $V_{SUB}$ ) · reset gate clock voltage ( $V_{RGL}$ ) setting value.

The setting values of substrate voltage and reset gate clock voltage are indicated on the back of the image sensor by a special code. Adjust substrate voltage ( $V_{SUB}$ ) and reset gate clock voltage ( $V_{RGL}$ ) to the indicated voltage. Fluctuation range after adjustment is  $\pm 3\%$ .

$V_{SUB}$  code    one character indication    □ □  
 $V_{RGL}$  code    one character indication    ↑ ↑  
 $V_{RGL}$  code    $V_{SUB}$  code

Code and optimal setting correspond to each other as follows.

$V_{RGL}$ code	1	2	3	4	5	6	7
Optimal setting	1.0	1.5	2.0	2.5	3.0	3.5	4.0

$V_{SUB}$ code	E	f	G	h	J	K	L	m	N	P	Q	R	S	T	U	V	W	X	Y	Z
Optimal setting	9.0	9.5	10.0	10.5	11.0	11.5	12.0	12.5	13.0	13.5	14.0	14.5	15.0	15.5	16.0	16.5	17.0	17.5	18.0	18.5

<Example> "5L" →  $V_{RGL} = 3.0\text{V}$   
 $V_{SUB} = 12.0\text{V}$

\*2  $V_L$  setting is the  $V_{VL}$  voltage of the vertical transfer clock waveform.

\*3 1) Current to each pin when 18V is applied to  $V_{DD}$ ,  $V_{OUT}$ ,  $V_{SS}$  and  $SUB$  pins, while pins that are not tested are grounded.  
 2) Current to each pin when 20V is applied sequentially to  $V_{\phi 1}$ ,  $V_{\phi 2}$ ,  $V_{\phi 3}$  and  $V_{\phi 4}$  pins, while pins that are not tested are grounded. However, 20V is applied to  $SUB$  pin.  
 3) Current to each pin when 15V is applied sequentially to  $RG$ ,  $LH\phi 1$ ,  $H\phi 1$ ,  $H\phi 2$  and  $V_{GG}$  pins, while pins that are not tested are grounded. However, 15V is applied to  $SUB$  pin.  
 4) Current to  $V_L$  pin when 30V is applied to  $V_{\phi 1}$ ,  $V_{\phi 2}$ ,  $V_{\phi 3}$ ,  $V_{\phi 4}$ ,  $V_{DD}$  and  $V_{OUT}$  pins or when, 24V is applied to  $RG$  pin or when, 20V is applied to  $V_{GG}$ ,  $V_{SS}$ ,  $H\phi 1$ ,  $H\phi 2$  and  $LH\phi 1$  pins, while  $V_L$  pin is grounded. However,  $GND$  and  $SUB$  pins are left open.

\*4 Current to  $SUB$  pin when 55V is applied to  $SUB$  pin, while pins that are not tested are grounded.

## Clock Voltage Conditions

Item	Symbol	Min.	Typ.	Max.	Unit	Waveform diagram	Remarks
Readout clock voltage	$V_{VT}$	14.55	15.0	15.45	V	1	
Vertical transfer clock voltage	$V_{VH1}, V_{VH2}$	-0.05	0	0.05	V	2	$V_{VH} = (V_{VH1} + V_{VH2})/2$
	$V_{VH3}, V_{VH4}$	-0.2	0	0.05	V	2	
	$V_{VL1}, V_{VL2}, V_{VL3}, V_{VL4}$	-9.0	-8.5	-8.0	V	2	$V_{VL} = (V_{VL3} + V_{VL4})/2$
	$V_{\phi V}$	7.8	8.5	9.05	V	2	$V_{\phi V} = V_{VHn} - V_{VLn} (n = 1 \text{ to } 4)$
	$ V_{VH1} - V_{VH2} $			0.1	V	2	
	$V_{VH3} - V_{VH}$	-0.25		0.1	V	2	
	$V_{VH4} - V_{VH}$	-0.25		0.1	V	2	
	$V_{VHH}$			0.5	V	2	High-level coupling
	$V_{VHL}$			0.5	V	2	High-level coupling
	$V_{VLH}$			0.5	V	2	Low-level coupling
	$V_{VLL}$			0.5	V	2	Low-level coupling
Horizontal transfer clock voltage	$V_{\phi H}, V_{\phi LH}$	4.75	5.0	5.25	V	3	*5
	$V_{HL}, V_{LHL}$	-0.05	0	0.05	V	3	*5
Reset gate clock voltage	$V_{\phi RG}$	4.5	5.0	5.5	V	4	*6
	$V_{RGLH} - V_{RGLL}$			0.8	V	4	Low-level coupling
Substrate clock voltage	$V_{\phi SUB}$	22.5	23.5	24.5	V	5	

\*5 The horizontal final stage transfer clock input pin  $LH\phi_1$  is connected to the horizontal transfer clock input pin  $H\phi_1$ .

\*6 The reset gate clock voltage need not be adjusted when reset gate clock is driven when the specifications are as given below. In this case, the reset gate clock voltage setting indicated on the back of the image sensor has not significance.

Item	Symbol	Min.	Typ.	Max.	Unit	Waveform diagram	Remarks
Reset gate clock voltage	$V_{RGL}$	-0.2	0	0.2	V	4	
	$V_{\phi RG}$	8.5	9.0	9.5	V	4	

**Clock Equivalent Circuit Constant**

Item	Symbol	Min.	Typ.	Max.	Unit	Remarks
Capacitance between vertical transfer clock and GND	$C\phi V1, C\phi V3$		1000		pF	
	$C\phi V2, C\phi V4$		560		pF	
Capacitance between vertical transfer clocks	$C\phi V12, C\phi V34$		470		pF	
	$C\phi V23, C\phi V41$		330		pF	
	$C\phi V13$		220		pF	
	$C\phi V24$		100		pF	
Capacitance between horizontal transfer clock and GND	$C\phi H1, C\phi H2$		47		pF	
Capacitance between horizontal transfer clocks	$C\phi HH$		43		pF	
Capacitance between horizontal final stage transfer clock and GND	$C\phi LH$		8		pF	
Capacitance between reset gate clock and GND	$C\phi RG$		8		pF	
Capacitance between substrate clock and GND	$C\phi SUB$		270		pF	
Vertical transfer clock series resistor	$R1, R2, R3, R4$		80		$\Omega$	
Vertical transfer clock ground resistor	$R_{GND}$		15		$\Omega$	
Horizontal transfer clock series resistor	$R\phi H$		15		$\Omega$	

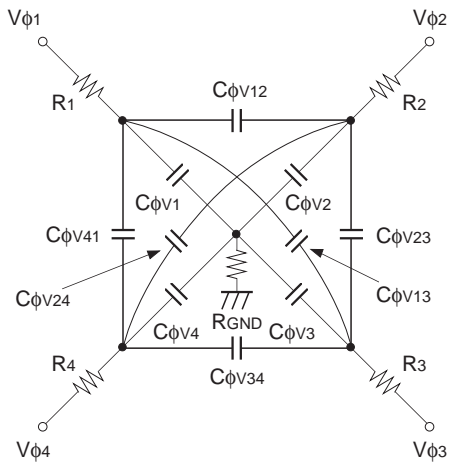

**Vertical transfer clock equivalent circuit**

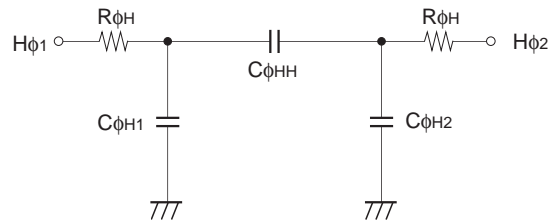

**Horizontal transfer clock equivalent circuit**

Drive Clock Waveform Conditions

(1) Readout clock waveform

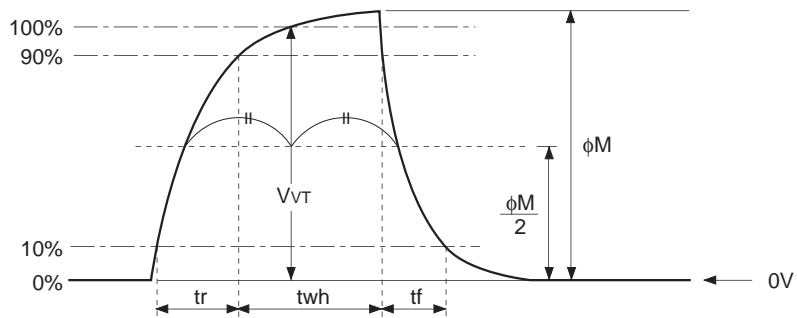

(2) Vertical transfer clock waveform

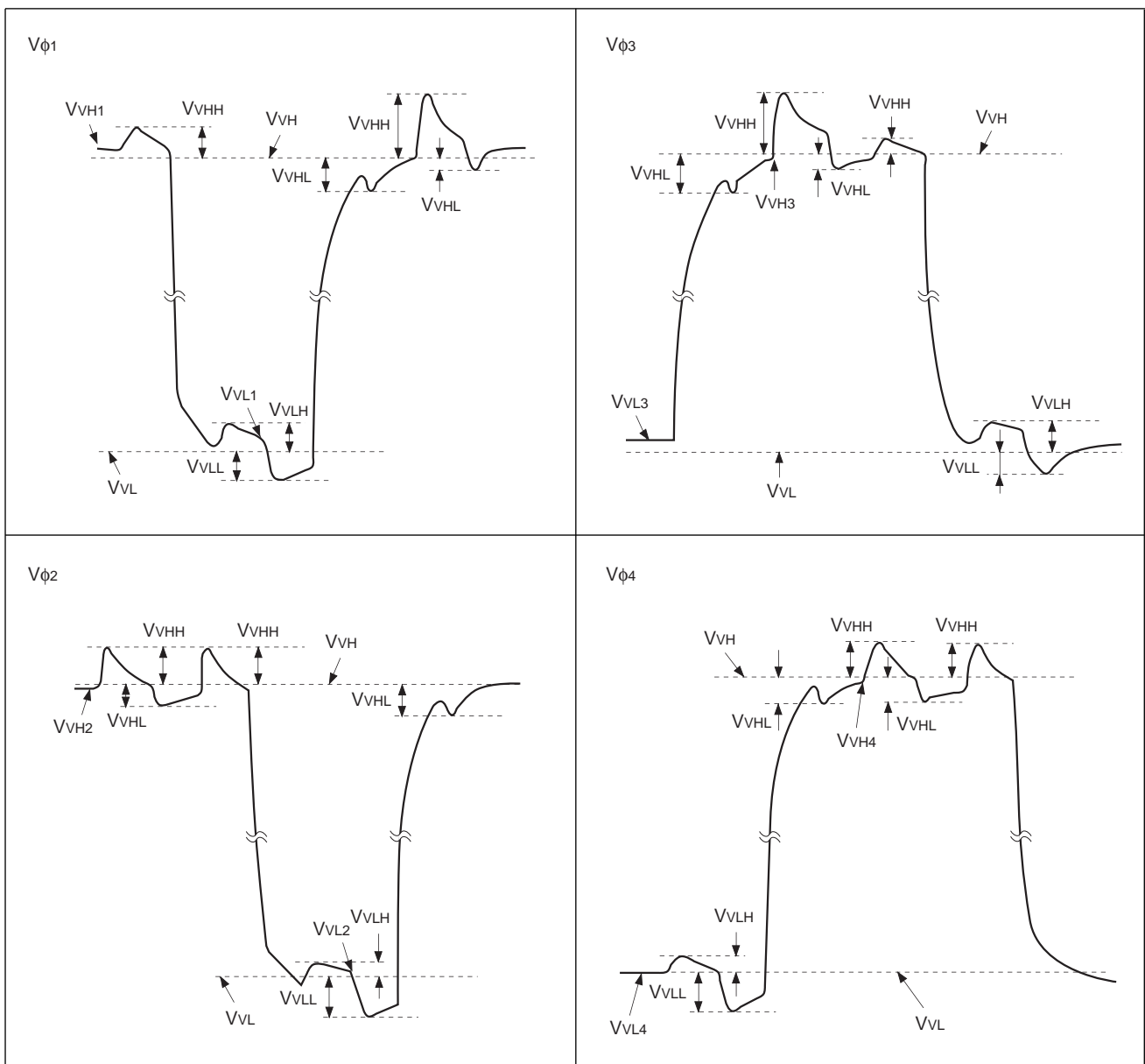

$$V_{VH} = (V_{VH1} + V_{VH2})/2$$

$$V_{VL} = (V_{VL3} + V_{VL4})/2$$

$$V_{\phi V} = V_{VHN} - V_{VLn} \quad (n = 1 \text{ to } 4)$$

**(3) Horizontal transfer clock waveform**

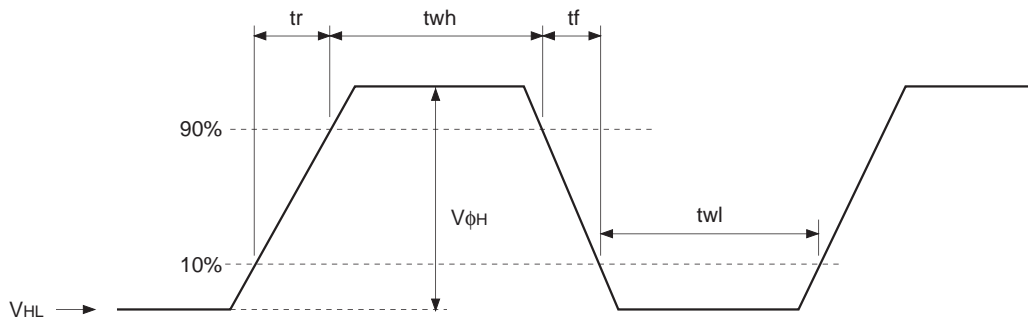

**(4) Reset gate clock waveform**

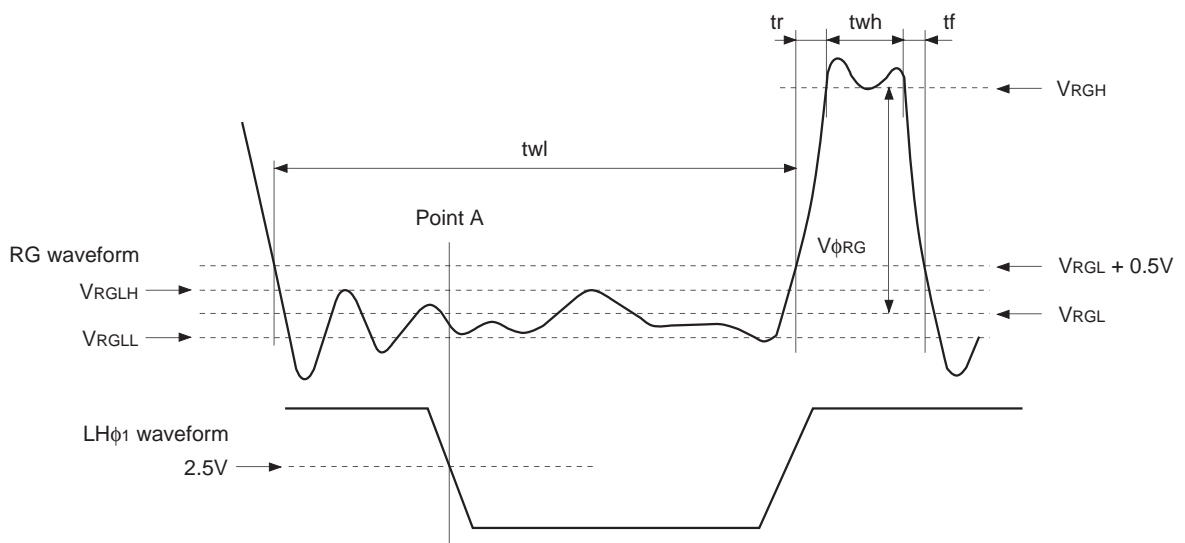

$V_{RGLH}$  is the maximum value and  $V_{RGLL}$  is the minimum value of the coupling waveform during the period from Point A in the above diagram until the rising edge of RG.

In addition,  $V_{RGL}$  is the average value of  $V_{RGLH}$  and  $V_{RGLL}$ .

$$V_{RGL} = (V_{RGLH} + V_{RGLL})/2$$

Assuming  $V_{RGH}$  is the minimum value during the interval  $t_{wh}$ , then:

$$V_{\phi RG} = V_{RGH} - V_{RGL}$$

(5) Substrate clock waveform

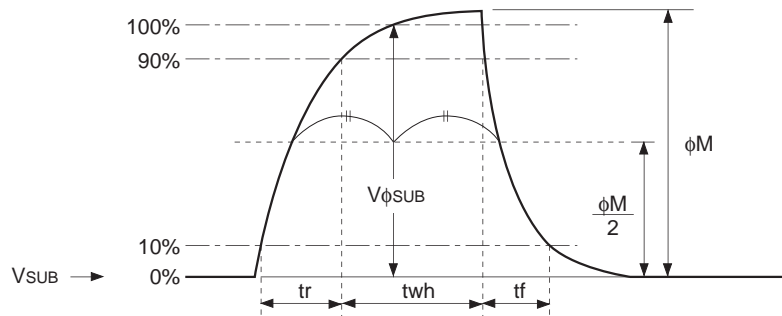

**Clock Switching Characteristics**

**Note)** Because the horizontal final stage transfer clock LHφ1 is connected to the horizontal transfer clock Hφ1, specifications will be the same as Hφ1.

Item	Symbol	twh			twl			tr			tf			Unit	Remarks
		Min.	Typ.	Max.	Min.	Typ.	Max.	Min.	Typ.	Max.	Min.	Typ.	Max.		
Readout clock	V <sub>T</sub>	2.3	2.5						0.5			0.5		μs	During readout
Vertical transfer clock	Vφ1, Vφ2, Vφ3, Vφ4										15		250	ns	*1
Horizontal transfer clock	During imaging	Hφ1, LHφ1	18	24		19.5	26		10	17.5		10	17.5	ns	*2
		Hφ2	21	26		19	24		10	15		10	15		
	During parallel-serial conversion	Hφ1, LHφ1		5.38					0.01			0.01		μs	
		Hφ2					5.38		0.01			0.01			
Reset gate clock	φ <sub>RG</sub>	11	13			51		3			3		ns		
Substrate clock	φ <sub>SUB</sub>	1.5	1.8						0.5			0.5	μs	During drain charge	

\*1 When vertical transfer clock driver CXD1267AN is used.

\*2  $t_f \geq t_r - 2ns$ , and the cross-point voltage ( $V_{CR}$ ) for the Hφ1 · LHφ1 rising side of the Hφ1 · LHφ1 and Hφ2 waveforms must be at least 2.5V.

Item	Symbol	two			Unit	Remarks
		Min.	Typ.	Max.		
Horizontal transfer clock	Hφ1 · LHφ1, Hφ2	16	20		ns	*3

\*3 The overlap period for twh and twl of horizontal transfer clocks Hφ1 · LHφ1 and Hφ2 is two.

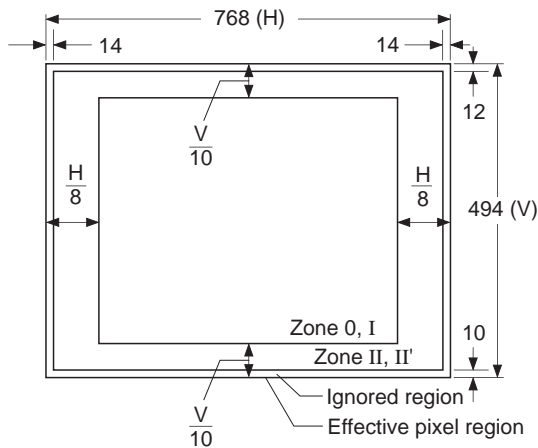

Image Sensor Characteristics

(Ta = 25°C)

Item	Symbol	Min.	Typ.	Max.	Unit	Measurement method	Remarks
Sensitivity	S	360	460		mV	1	
Saturation signal	Ysat	600			mV	2	Ta = 60°C
Smear	Sm		0.002	0.007	%	3	
Video signal shading	SHy			20	%	4	Zone 0, I
				25	%	4	Zone 0 to II'
Uniformity between video signal channels	$\Delta Sr$			10	%	5	
	$\Delta Sb$			10	%	5	
Dark signal	Ydt			2	mV	6	Ta = 60°C
Dark signal shading	$\Delta Ydt$			1	mV	7	Ta = 60°C
Flicker Y	Fy			2	%	8	
Flicker R-Y	Fcr			5	%	8	
Flicker B-Y	Fcb			5	%	8	
Line crawl R	Lcr			3	%	9	
Line crawl G	Lcg			3	%	9	
Line crawl B	Lcb			3	%	9	
Line crawl W	Lcw			3	%	9	
Lag	Lag			0.5	%	10	

Zone Definition of Video Signal Shading



Measurement System

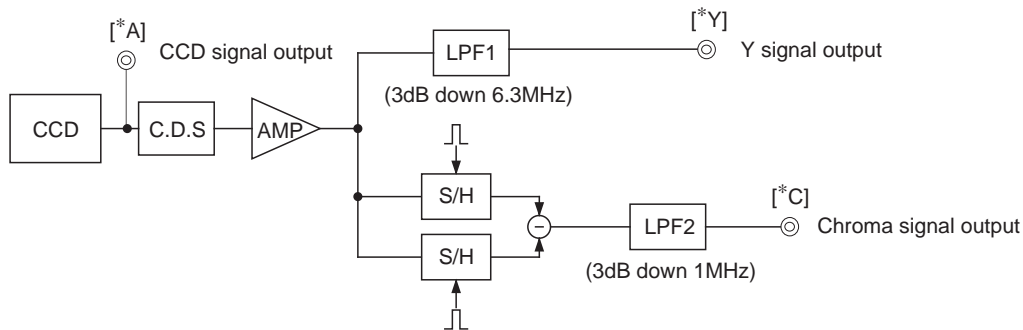

**Note)** Adjust the amplifier gain so that the gain between [\*A] and [\*Y] and between [\*A] and [\*C] equal 1.

**Image Sensor Characteristics Measurement Method**

◎ **Measurement conditions**

- 1) In the following measurements, the substrate voltage and the reset gate clock voltage are set to the values indicated on the device, and the device drive conditions are at the typical values of the bias and clock voltage conditions.
- 2) In the following measurements, spot blemishes are excluded and, unless otherwise specified, the optical black level (OB) is used as the reference for the signal output, which is taken as the value of Y signal output or chroma signal output of the measurement system.

◎ **Color coding of this image sensor & Composition of luminance (Y) and chroma (color difference) signals**

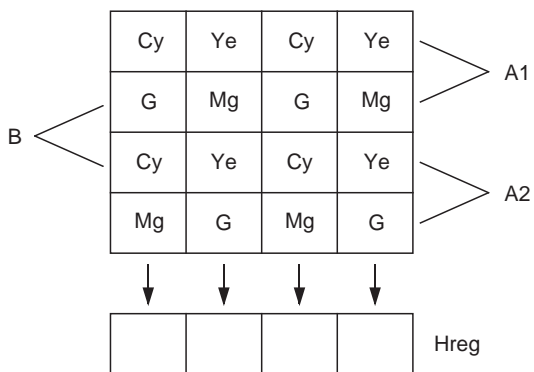

As shown in the left figure, fields are read out. The charge is mixed by pairs such as A1 and A2 in the A field. (pairs such as B in the B field)  
 As a result, the sequence of charges output as signals from the horizontal shift register (Hreg) is, for line A1, (G + Cy), (Mg + Ye), (G + Cy), and (Mg + Ye).

These signals are processed to form the Y signal and chroma (color difference) signal. The Y signal is formed by adding adjacent signals, and the chroma signal is formed by subtracting adjacent signals. In other words, the approximation:

$$Y = \{(G + Cy) + (Mg + Ye)\} \times 1/2$$

$$= 1/2 \{2B + 3G + 2R\}$$

is used for the Y signal, and the approximation:

$$R - Y = \{(Mg + Ye) - (G + Cy)\}$$

$$= \{2R - G\}$$

is used for the chroma (color difference) signal. For line A2, the signals output from Hreg in sequence are

$$(Mg + Cy), (G + Ye), (Mg + Cy), (G + Ye).$$

The Y signal is formed from these signals as follows:

$$Y = \{(G + Ye) + (Mg + Cy)\} \times 1/2$$

$$= 1/2 \{2B + 3G + 2R\}$$

This is balanced since it is formed in the same way as for line A1.

In a like manner, the chroma (color difference) signal is approximated as follows:

$$-(B - Y) = \{(G + Ye) - (Mg + Cy)\}$$

$$= -\{2B - G\}$$

In other words, the chroma signal can be retrieved according to the sequence of lines from R - Y and - (B - Y) in alternation. This is also true for the B field.

## ◎ Definition of standard imaging conditions

### 1) Standard imaging condition I:

Use a pattern box (luminance 706cd/m<sup>2</sup>, color temperature of 3200K halogen source) as a subject. (Pattern for evaluation is not applicable.) Use a testing standard lens with CM500S (t = 1.0mm) as an IR cut filter and image at F5.6. The luminous intensity to the sensor receiving surface at this point is defined as the standard sensitivity testing luminous intensity.

### 2) Standard imaging condition II:

Image a light source (color temperature of 3200K) with a uniformity of brightness within 2% at all angles. Use a testing standard lens with CM500S (t = 1.0mm) as an IR cut filter. The luminous intensity is adjusted to the value indicated in each testing item by the lens diaphragm.

#### 1. Sensitivity

Set to standard imaging condition I. After selecting the electronic shutter mode with a shutter speed of 1/250s, measure the Y signal (Y<sub>s</sub>) at the center of the screen and substitute the value into the following formula.

$$S = Y_s \times \frac{250}{60} \text{ [mV]}$$

#### 2. Saturation signal

Set to standard imaging condition II. After adjusting the luminous intensity to 10 times the intensity with average value of the Y signal output, 200mV, measure the minimum value of the Y signal.

#### 3. Smear

Set to standard imaging condition II. With the lens diaphragm at F5.6 to F8, adjust the luminous intensity to 500 times the intensity with average value of the Y signal output, 200mV. When the readout clock is stopped and the charge drain is executed by the electronic shutter at the respective H blankings, measure the maximum value Y<sub>Sm</sub> [mV] of the Y signal output and substitute the value into the following formula.

$$S_m = \frac{Y_{Sm}}{200} \times \frac{1}{500} \times \frac{1}{10} \times 100 \text{ [%]} \text{ (1/10V method conversion value)}$$

#### 4. Video signal shading

Set to standard imaging condition II. With the lens diaphragm at F5.6 to F8, adjust the luminous intensity so that the average value of the Y signal output is 200mV. Then measure the maximum (Y<sub>max</sub> [mV]) and minimum (Y<sub>min</sub> [mV]) values of the Y signal and substitute the values into the following formula.

$$SH_y = (Y_{max} - Y_{min})/200 \times 100 \text{ [%]}$$

#### 5. Uniformity between video signal channels

Set to standard imaging condition II. Adjust the luminous intensity so that the average value of the Y signal output is 200mV, and then measure the maximum (C<sub>rmax</sub>, C<sub>bmax</sub> [mV]) and minimum (C<sub>rmin</sub>, C<sub>bmin</sub> [mV]) values of the R – Y and B – Y channels of the chroma signal and substitute the values into the following formula.

$$\Delta S_r = | (C_{rmax} - C_{rmin})/200 | \times 100 \text{ [%]}$$

$$\Delta S_b = | (C_{bmax} - C_{bmin})/200 | \times 100 \text{ [%]}$$

#### 6. Dark signal

Measure the average value of the Y signal output (Y<sub>dt</sub> [mV]) with the device ambient temperature 60°C and the device in the light-obstructed state, using the horizontal idle transfer level as a reference.

7. Dark signal shading

After measuring 6, measure the maximum (Ydmax [mV]) and minimum (Ydmin [mV]) values of the Y signal output and substitute the values into the following formula.

$$\Delta Y_{dt} = Y_{dmax} - Y_{dmin} \text{ [mV]}$$

8. Flicker

1) Fy

Set to standard imaging condition II. Adjust the luminous intensity so that the average value of the Y signal output is 200mV, and then measure the difference in the signal level between fields ( $\Delta Y_f$  [mV]). Then substitute the value into the following formula.

$$F_y = (\Delta Y_f / 200) \times 100 \text{ [%]}$$

2) Fcr, Fcb

Set to standard imaging condition II. Adjust the luminous intensity so that the average value of the Y signal output is 200mV, insert an R or B filter, and then measure both the difference in the signal level between fields of the chroma signal ( $\Delta C_r, \Delta C_b$ ) as well as the average value of the chroma signal output (CAr, CAb). Substitute the values into the following formula.

$$F_{ci} = (\Delta C_i / CA_i) \times 100 \text{ [%]} \text{ (i = r, b)}$$

9. Line crawls

Set to standard imaging condition II. Adjust the luminous intensity so that the average value of the Y signal output is 200mV, and then insert a white subject and R, G, and B filters and measure the difference between Y signal lines for the same field ( $\Delta Y_{lw}, \Delta Y_{lr}, \Delta Y_{lg}, \Delta Y_{lb}$  [mV]). Substitute the values into the following formula.

$$L_{ci} = (\Delta Y_{li} / 200) \times 100 \text{ [%]} \text{ (i = w, r, g, b)}$$

10. Lag

Adjust the Y signal output value generated by strobe light to 200mV. After setting the strobe light so that it strobos with the following timing, measure the residual signal (Ylag). Substitute the value into the following formula.

$$Lag = (Y_{lag} / 200) \times 100 \text{ [%]}$$

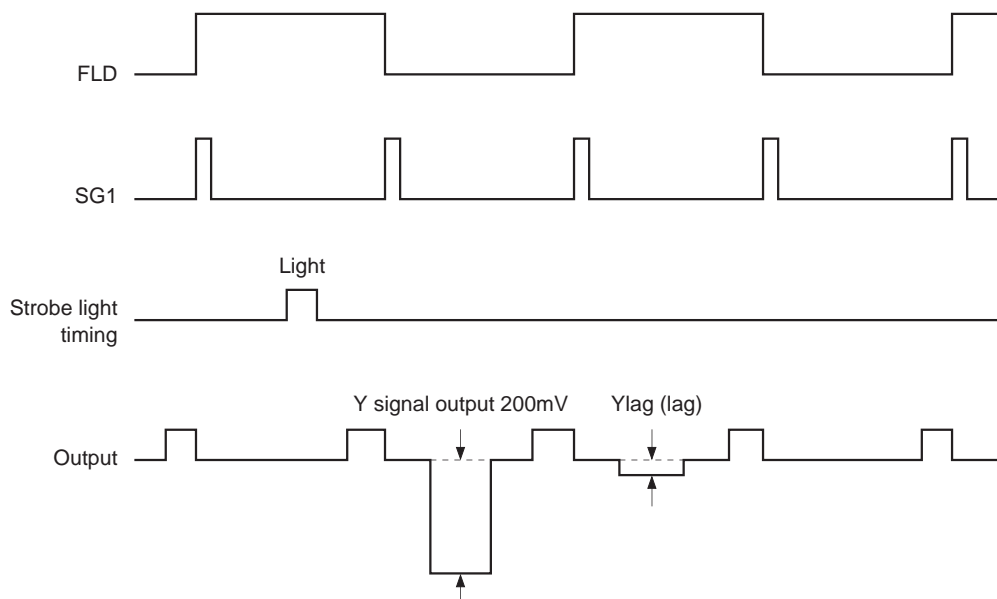

Drive Circuit

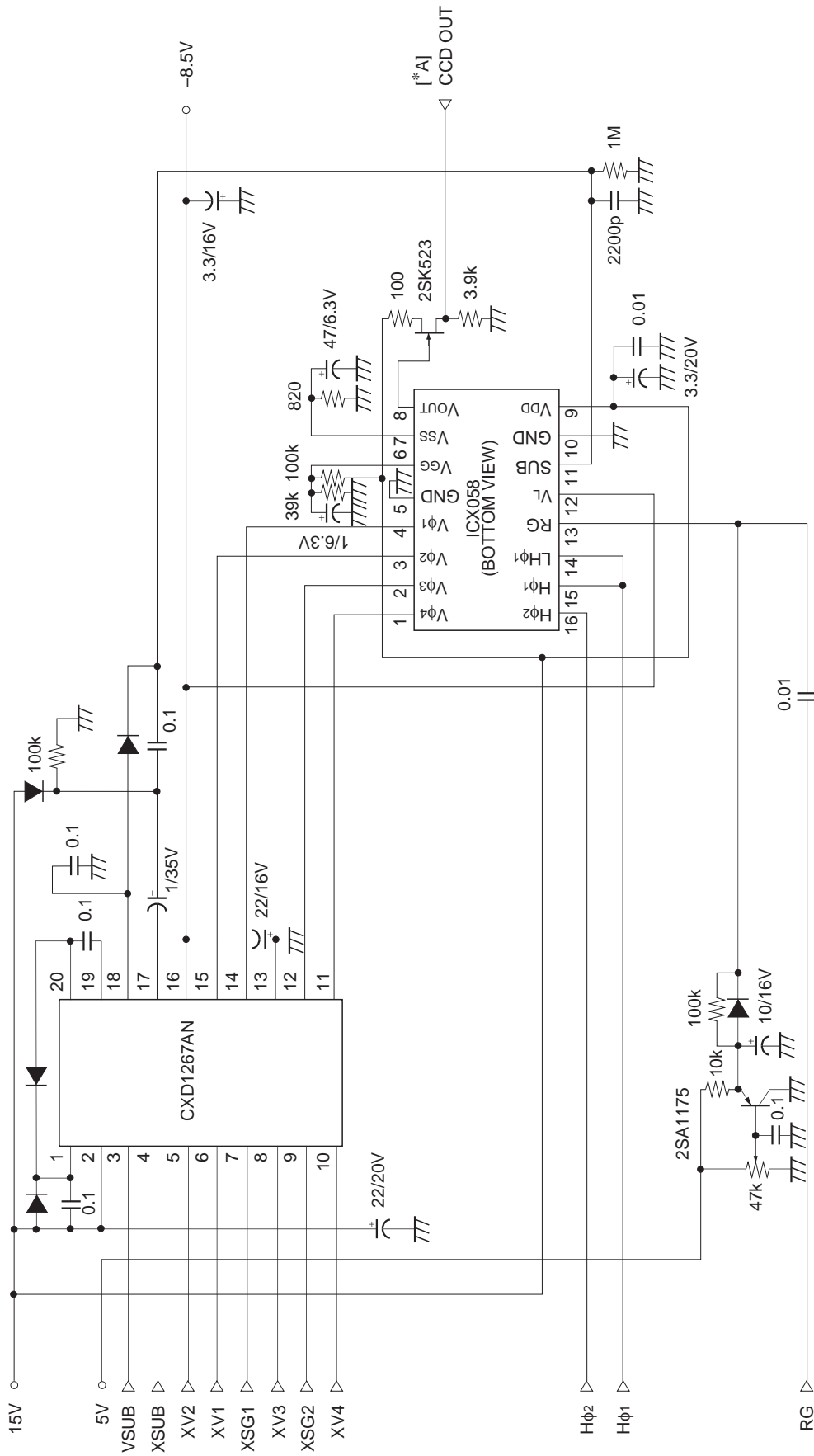

**Spectral Sensitivity Characteristics**

(Includes lens characteristics, excludes light source characteristics)

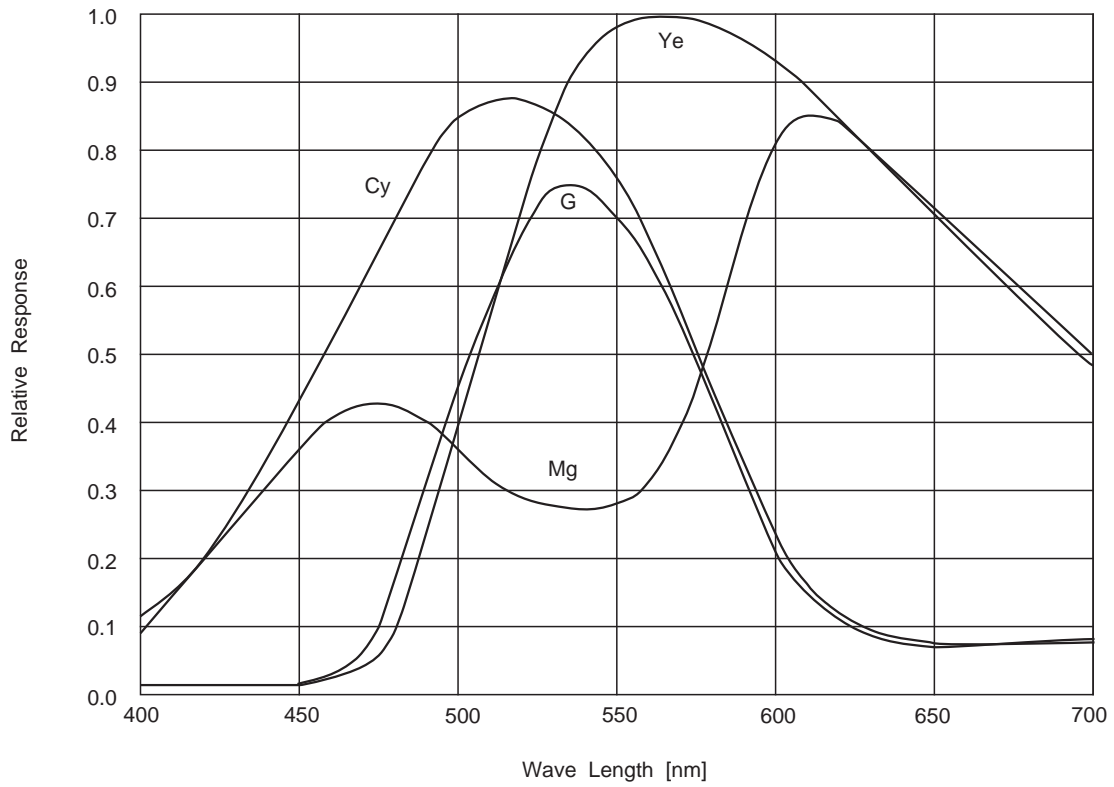

**Sensor Readout Clock Timing Chart**

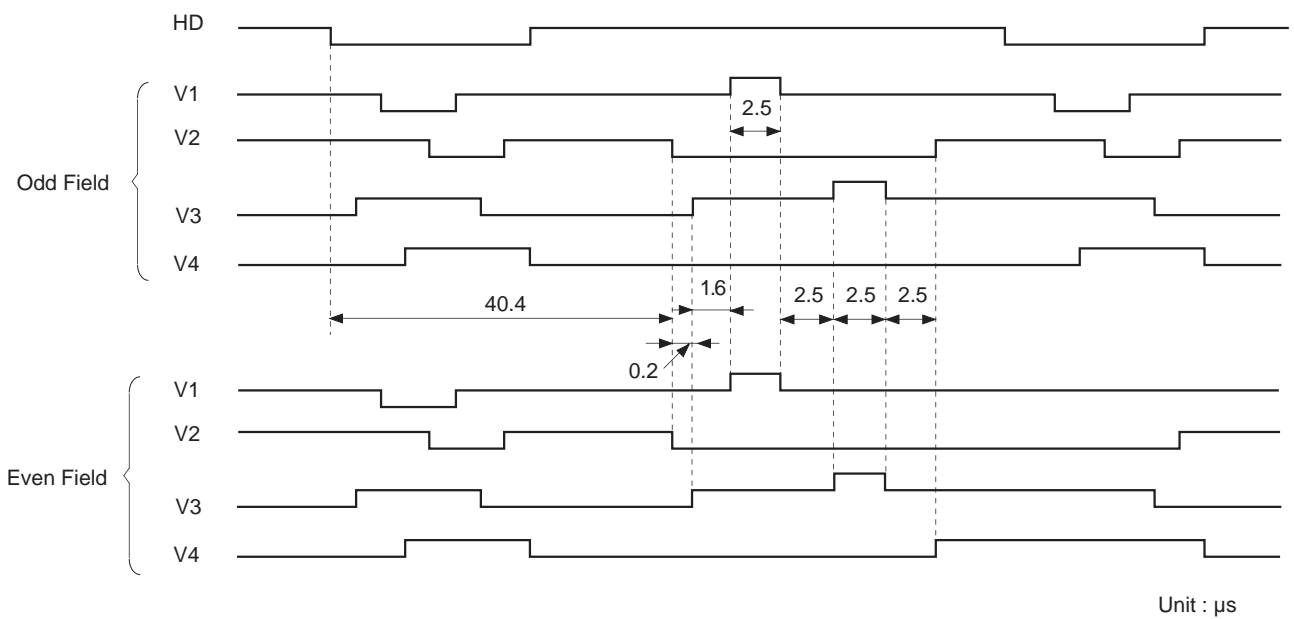

Drive Timing Chart (Vertical Sync)

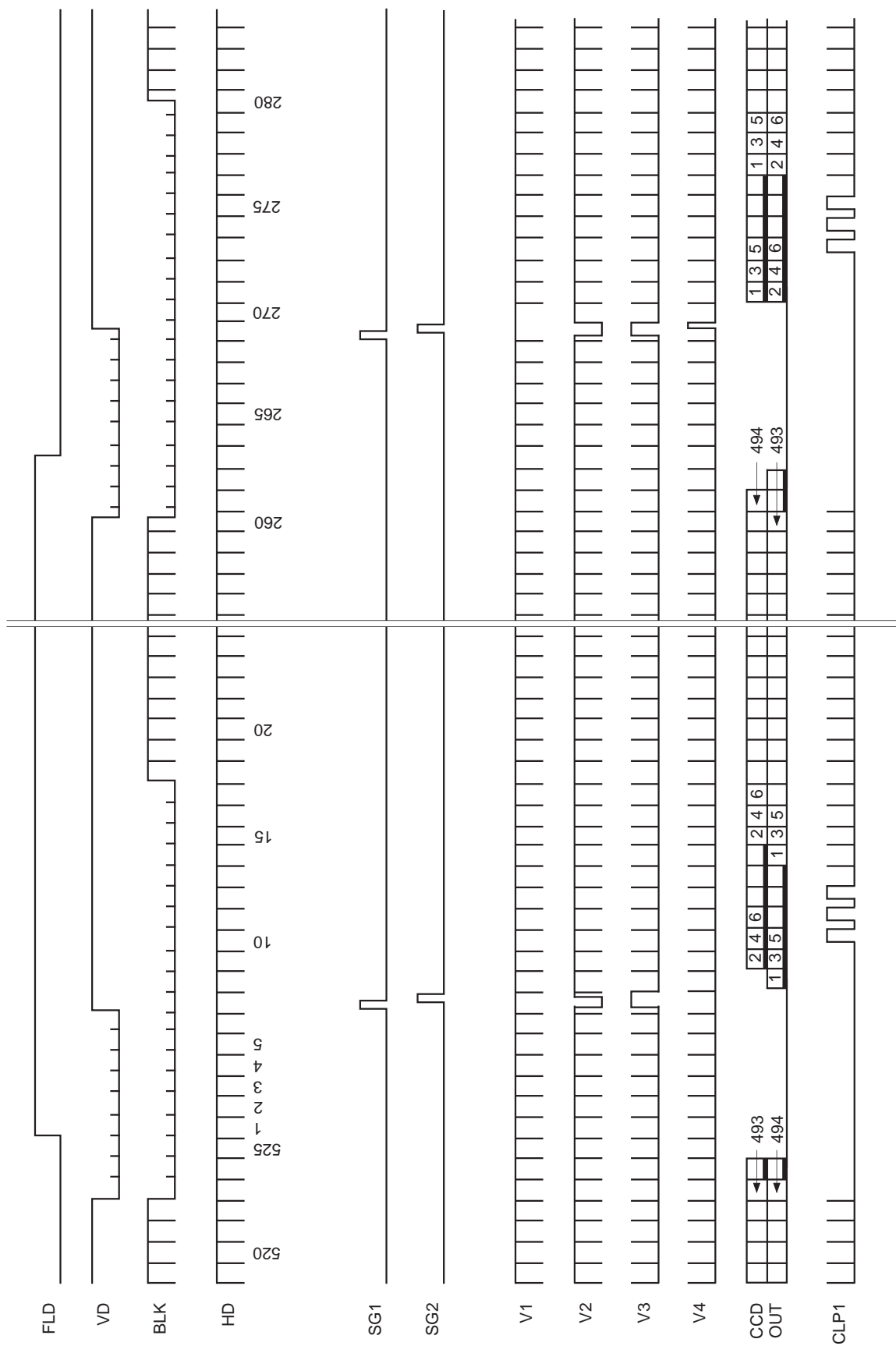

Drive Timing Chart (Horizontal Sync)

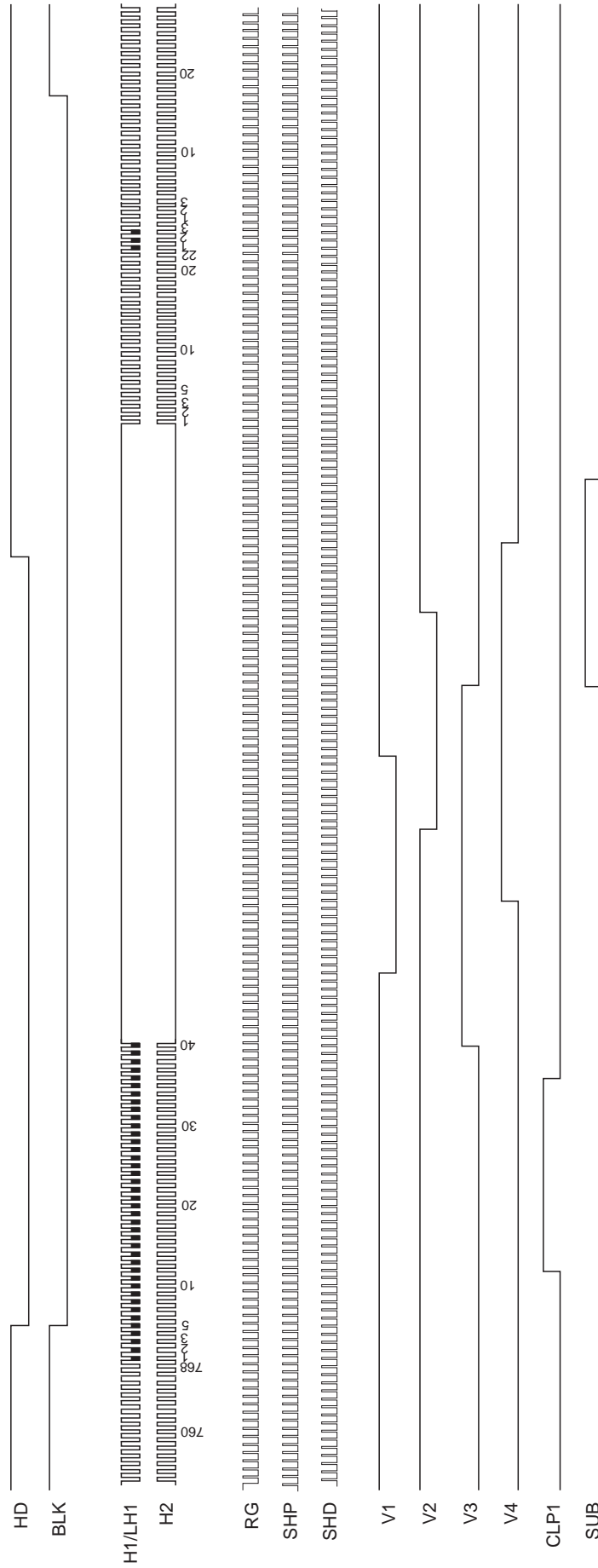



## Notes on Handling

### 1) Static charge prevention

CCD image sensors are easily damaged by static discharge. Before handling be sure to take the following protective measures.

- Either handle bare handed or use non-chargeable gloves, clothes or material.  
Also use conductive shoes.
- When handling directly use an earth band.
- Install a conductive mat on the floor or working table to prevent the generation of static electricity.
- Ionized air is recommended for discharge when handling CCD image sensor.
- For the shipment of mounted substrates, use boxes treated for the prevention of static charges.

### 2) Soldering

- Make sure the package temperature does not exceed 80°C.
- Solder dipping in a mounting furnace causes damage to the glass and other defects. Use a ground 30W soldering iron and solder each pin in less than 2 seconds. For repairs and remount, cool sufficiently.
- To dismount an image sensor, do not use a solder suction equipment. When using an electric desoldering tool, use a thermal controller of the zero cross On/Off type and connect it to ground.

### 3) Dust and dirt protection

Image sensors are packed and delivered by taking care of protecting its glass plates from harmful dust and dirt. Clean glass plates with the following operation as required, and use them.

- Perform all assembly operations in a clean room (class 1000 or less).
- Do not either touch glass plates by hand or have any object come in contact with glass surfaces. Should dirt stick to a glass surface, blow it off with an air blower. (For dirt stuck through static electricity ionized air is recommended.)
- Clean with a cotton bud and ethyl alcohol if the grease stained. Be careful not to scratch the glass.
- Keep in a case to protect from dust and dirt. To prevent dew condensation, preheat or precool when moving to a room with great temperature differences.
- When a protective tape is applied before shipping, just before use remove the tape applied for electrostatic protection. Do not reuse the tape.

### 4) Installing (attaching)

- Remain within the following limits when applying a static load to the package. Do not apply any load more than 0.7mm inside the outer perimeter of the glass portion, and do not apply any load or impact to limited portions. (This may cause cracks in the package.)

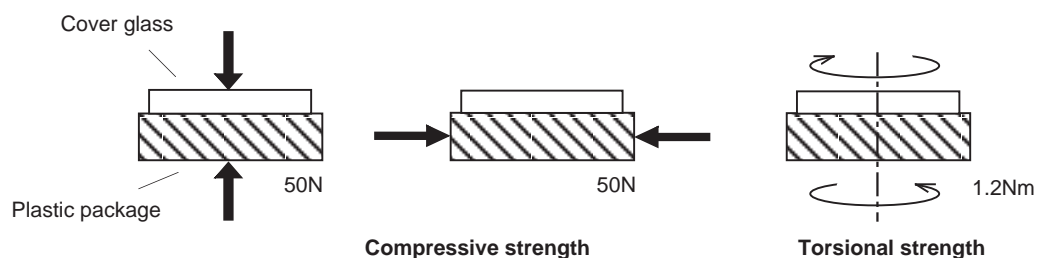

- If a load is applied to the entire surface by a hard component, bending stress may be generated and the package may fracture, etc., depending on the flatness of the bottom of the package. Therefore, for installation, use either an elastic load, such as a spring plate, or an adhesive.

- c) The adhesive may cause the marking on the rear surface to disappear, especially in case the regulated voltage value is indicated on the rear surface. Therefore, the adhesive should not be applied to this area, and indicated values should be transferred to the other locations as a precaution.
- d) The notch of the package is used for directional index, and that can not be used for reference of fixing. In addition, the cover glass and seal resin may overlap with the notch of the package.
- e) If the lead bend repeatedly and the metal, etc., clash or rub against the package, the dust may be generated by the fragments of resin.
- f) Acrylate anaerobic adhesives are generally used to attach CCD image sensors. In addition, cyanoacrylate instantaneous adhesives are sometimes used jointly with acrylate anaerobic adhesives. (reference)

#### 5) Others

- a) Do not expose to strong light (sun rays) for long periods, color filters will be discolored. When high luminance objects are imaged with the exposure level control by electronic-iris, the luminance of the image-plane may become excessive and discolor of the color filter will possibly be accelerated. In such a case, it is advisable that taking-lens with the automatic-iris and closing of the shutter during the power-off mode should be properly arranged. For continuous using under cruel condition exceeding the normal using condition, consult our company.
- b) Exposure to high temperature or humidity will affect the characteristics. Accordingly avoid storage or usage in such conditions.
- c) The brown stain may be seen on the bottom or side of the package. But this does not affect the CCD characteristics.

Package Outline Unit: mm

16pin DIP (450mil)

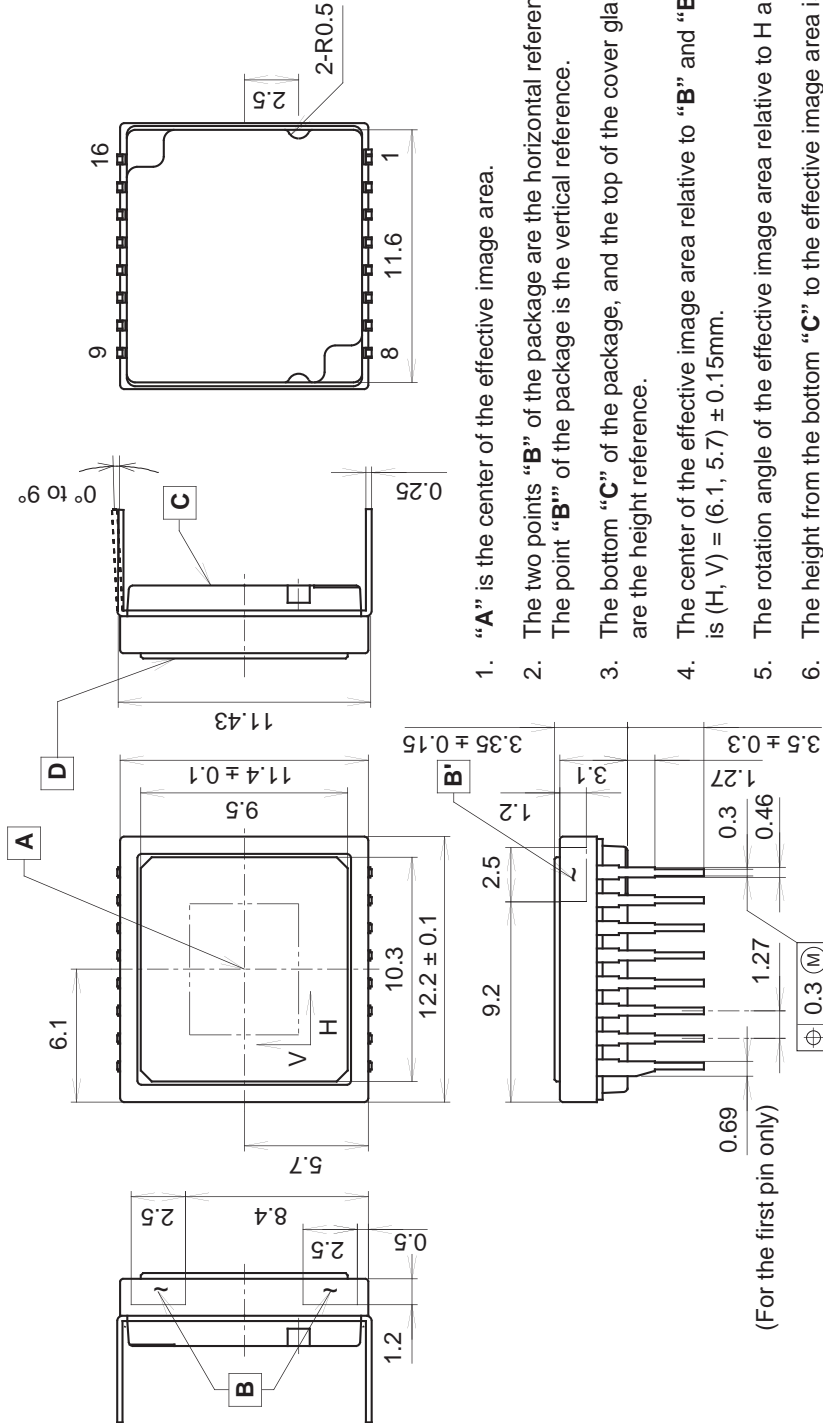

1. "A" is the center of the effective image area.
2. The two points "B" of the package are the horizontal reference. The point "B'" of the package is the vertical reference.
3. The bottom "C" of the package, and the top of the cover glass "D" are the height reference.
4. The center of the effective image area relative to "B" and "B'" is (H, V) = (6.1, 5.7) ± 0.15mm.
5. The rotation angle of the effective image area relative to H and V is ± 1°.
6. The height from the bottom "C" to the effective image area is 1.41 ± 0.10mm. The height from the top of the cover glass "D" to the effective image area is 1.94 ± 0.15mm.
7. The tilt of the effective image area relative to the bottom "C" is less than 50µm. The tilt of the effective image area relative to the top "D" of the cover glass is less than 50µm.
8. The thickness of the cover glass is 0.75mm, and the refractive index is 1.5.
9. The notches on the bottom of the package are used only for directional index, they must not be used for reference of fixing.

PACKAGE STRUCTURE

PACKAGE MATERIAL	Plastic
LEAD TREATMENT	GOLD PLATING
LEAD MATERIAL	42 ALLOY
PACKAGE WEIGHT	0.9g