

# Dual Varicap Diode

## Features

- Silicon Epitaxial Planar Diode
- Common cathode
- High capacitance ratio

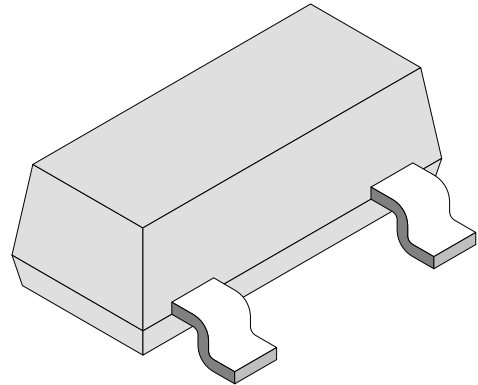

## Applications

Tuning of separate resonant circuits, push-pull circuits in FM range, for car radios

94 8550

## Order Instruction

Type	Type Differentiation	Ordering Code	Remarks
BB824-2	$V_{RRM} = 20 \text{ V}$ , $C_D$ 42,3-43, 8pF	BB824-2-GS08	Tape and Reel
BB824-3	$V_{RRM} = 20 \text{ V}$ , $C_D$ 43,7-45, 8pF	BB824-3-GS08	Tape and Reel

## Absolute Maximum Ratings

$T_j = 25^\circ\text{C}$

Parameter	Test Conditions	Type	Symbol	Value	Unit
Repetitive peak reverse voltage			$V_{RRM}$	20	V
Reverse voltage			$V_R$	18	V
Forward current			$I_F$	50	mA
Junction temperature			$T_j$	125	$^\circ\text{C}$
Storage temperature range			$T_{stg}$	-55...+150	$^\circ\text{C}$

## Electrical Characteristics

$T_j = 25^\circ\text{C}$

Parameter	Test Conditions	Type	Symbol	Min	Typ	Max	Unit
Reverse current	$V_R=16 \text{ V}$		$I_R$			20	nA
	$V_R=16 \text{ V}$ , $T_j=60^\circ\text{C}$					200	
Diode capacitance <sup>1)</sup>	$V_R=2 \text{ V}$	Group 2	$C_D$	42.5		43.8	pF
Diode capacitance		Group 3		43.7		45	
	$V_R=8 \text{ V}$	Group 2		17.5		19.2	
		Group 3		18.0		19.8	
Capacitance ratio	$V_R=2 \text{ V}$ , $8 \text{ V}$ , $f=1\text{MHz}$		$C_{D2}/C_{D8}$	2.25		2.45	
Series resistance	$V_R=2 \text{ V}$ , $f=100\text{MHz}$		$r_s$			0.5	$\Omega$

<sup>1)</sup> In the reverse voltage range of  $V_R=2...8\text{V}$  for 4 diodes taped in sequence the max. deviation is 3%.

**Dimensions in mm**

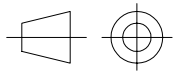
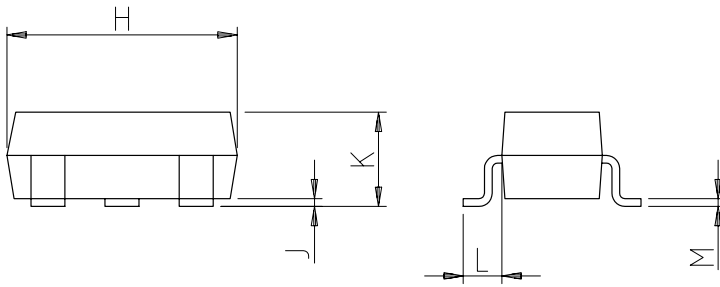

technical drawings  
according to DIN  
specifications

14384

SOT-23		
Dim	Min	Max
A	0.37	0.50
B	1.19	1.40
C	2.10	2.50
D	0.89	1.05
E	0.45	0.61
G	1.78	2.05
H	2.79	3.05
J	0.013	0.15
K	0.89	1.10
L	0.45	0.61
M	0.076	0.130
All Dimensions in mm		



## Ozone Depleting Substances Policy Statement

It is the policy of **Vishay Semiconductor GmbH** to

1. Meet all present and future national and international statutory requirements.
2. Regularly and continuously improve the performance of our products, processes, distribution and operating systems with respect to their impact on the health and safety of our employees and the public, as well as their impact on the environment.

It is particular concern to control or eliminate releases of those substances into the atmosphere which are known as ozone depleting substances (ODSs).

The Montreal Protocol (1987) and its London Amendments (1990) intend to severely restrict the use of ODSs and forbid their use within the next ten years. Various national and international initiatives are pressing for an earlier ban on these substances.

**Vishay Semiconductor GmbH** has been able to use its policy of continuous improvements to eliminate the use of ODSs listed in the following documents.

1. Annex A, B and list of transitional substances of the Montreal Protocol and the London Amendments respectively
2. Class I and II ozone depleting substances in the Clean Air Act Amendments of 1990 by the Environmental Protection Agency (EPA) in the USA
3. Council Decision 88/540/EEC and 91/690/EEC Annex A, B and C (transitional substances) respectively.

**Vishay Semiconductor GmbH** can certify that our semiconductors are not manufactured with ozone depleting substances and do not contain such substances.

**We reserve the right to make changes to improve technical design and may do so without further notice.**

Parameters can vary in different applications. All operating parameters must be validated for each customer application by the customer. Should the buyer use Vishay-Semiconductors products for any unintended or unauthorized application, the buyer shall indemnify Vishay-Semiconductors against all claims, costs, damages, and expenses, arising out of, directly or indirectly, any claim of personal damage, injury or death associated with such unintended or unauthorized use.

Vishay Semiconductor GmbH, P.O.B. 3535, D-74025 Heilbronn, Germany  
Telephone: 49 (0)7131 67 2831, Fax number: 49 (0)7131 67 2423