

FEATURES

- -55° to +125°C operation
- 16 to 40 VDC input
- Fully isolated
- Magnetic feedback
- Fixed frequency 600 kHz typical
- Topology – Single Ended Forward
- 50 V for up to 50 ms transient protection
- Inhibit and synchronization functions
- Indefinite short circuit protection
- Up to 30 watts output power
- Trim and remote sense on single output models
- Up to 84% efficiency

DC/DC CONVERTERS 28 VOLT INPUT

MTR SERIES 30 WATT



MODELS		
VDC OUTPUT		
SINGLE	DUAL	TRIPLE
3.3	±5	+5 &
5	±12	±12
12	±15	+5 &
15		±15
18		

Size (max): Non-flanged: Single and dual output models, case H2 (H4 for MTR Dual with standard or ES screening, ht 0.417", 10.59 mm)
2.125 x 1.125 x 0.400 inches (53.98 x 28.58 x 10.16 mm)
Triple output models, case F1, 1.950 x 1.350 x 0.405 inches (49.53 x 34.29 x 10.29 mm)
Flanged: Single and dual output models, case K3 (or K5 for MTR Dual with standard or ES screening, ht. 0.417", 10.59 mm)
2.910 x 1.125 x 0.400 inches (73.91 x 28.58 x 10.16 mm)
Triple output models, case J1, 2.720 x 1.350 x 0.405 inches (69.09 x 34.29 x 10.29 mm)

Weight: Single and dual non-flanged 50 grams max., flanged 52 grams max.
Triple non-flanged 58 grams max., flanged 62 grams max.

Screening: Standard, ES, or 883 (Class H).

DESCRIPTION

The MTR Series™ of DC/DC converters offers up to 30 watts of output power from single, dual, or triple output configurations. They operate over the full military temperature range with up to 84% efficiency. MTR converters are packaged in hermetically sealed metal cases, making them ideal for use in military, aerospace and other high reliability applications.

CONVERTER DESIGN

The MTR converters are constant frequency, pulse-width modulated switching regulators which use a quasi-square wave, single ended, forward converter design. Tight load regulation is maintained via wide bandwidth magnetic feedback and, on single output models, through use of remote sense. On dual output models, the positive output is independently regulated and the negative output is cross regulated through the use of tightly coupled magnetics and shunt regulators. The MTR Series triple output DC/DC converter's design includes individual regulators on the auxiliary outputs which provide for no cross regulation error when a minimum 500 mA load is maintained on the main (+5) output.

Indefinite short circuit protection and overload protection are provided by a constant current-limit feature. This protective system senses current in the converter's secondary stage and limits it to approximately 115% of the maximum rated output current.

MTR converters are provided with internal filtering capacitors that help reduce the need for external components in normal operation. For systems that require compliance with MIL-STD-461C's CE03 standard, Interpoint offers filter/transient suppression modules (including the FMC-461, FMD-461 and FM-704A series filters) which will result in compliance. Contact your Interpoint representative for further details.

SYNCHRONIZATION

Synchronizing the converter with the system clock allows the designer to confine switching noise to clock transitions, minimizing interference and reducing the need for filtering. In sync mode, the converter will run at any frequency between 500 kHz and 675 kHz. The sync control operates with a quasi-TTL signal at any duty cycle between 40% and 60%. The sync pin must be connected to input common pin when not in use.

WIDE VOLTAGE RANGE

MTR converters are designed to provide full power operation over a full 16 to 40 VDC voltage range. Operation below 16 volts, including MIL-STD-704E emergency power conditions is possible with derated power. Refer to the low line dropout graph (Figure 22) for details.

IMPROVED DYNAMIC RESPONSE

The MTR Series feed-forward compensation system provides excellent dynamic response and noise rejection. Audio rejection is typically 50 dB. The minimum to maximum step line transient response is typically less than 4%.

INHIBIT FUNCTION

MTR converters provide an inhibit terminal that can be used to disable internal switching, resulting in no output and very low quiescent input current. The converter is inhibited when a TTL compatible low (≤ 0.8 V) is applied to the inhibit pin. The unit is enabled when the pin, which is internally connected to a pull-up resistor, is left unconnected or is connected to an open-collector gate. The open circuit output voltage associated with the inhibit pin is 9 to 11 V. In the inhibit mode, a maximum of 8 mA must be sunk from the inhibit pin.

MTR SERIES

30 WATT

DC/DC CONVERTERS

ABSOLUTE MAXIMUM RATINGS

- Input Voltage**
- 16 to 40 VDC
- Output Power**
- 25 to 30 watts depending on model
- Lead Soldering Temperature (10 sec per pin)**
- 300°C
- Storage Temperature Range (Case)**
- -65°C to +135°C

RECOMMENDED OPERATING CONDITIONS

- Input Voltage Range**
- 16 to 40 VDC continuous
 - 50 V for 50 msec transient
- Case Operating Temperature (Tc)**
- -55°C to +125°C full power
 - -55°C to +135°C absolute
- Derating Output Power/Current**
- Linearly from 100% at 125°C to 0% at 135°C

SYNC AND INHIBIT

- Sync (500 to 675 kHz)**
- Duty cycle 40% min, 60% max
 - Logic low 0.8 V max
 - Logic high 4.5 V min, 5 V max
 - Referenced to input common
 - If not used, connect to input common
- Inhibit TTL Open Collector**
- Logic low (output disabled)
Voltage ≤ 0.8 V
Inhibit pin current 8.0 mA max
 - Referenced to input common
 - Logic high (output enabled)
Open collector

TYPICAL CHARACTERISTICS

- Output Voltage Temperature Coefficient**
- 100 ppm/°C typical single and dual outputs
 - 200 ppm/°C main, 300 ppm/°C aux triple output
- Input to Output Capacitance**
- 50 pF typ (100 pF typ triple outputs)
- Current Limit**
- 115% of full load typical
- Isolation**
- 100 megohm minimum at 500 V
- Audio Rejection**
- 40 dB typ (50 dB typ triple output)
- Conversion Frequency**
- Free run 550 min, 600 typ, 650 max kHz
 - External sync 500 to 675 kHz
- Inhibit Pin Voltage (unit enabled)**
- 9 to 11 V

Electrical Characteristics: 25°C Tc, 28 VDC Vin, 100% load, free run, unless otherwise specified.

SINGLE OUTPUT MODELS		MTR283R3S			MTR2805S			MTR2812S			MTR2815S			MTR2818S			UNITS
PARAMETER	CONDITION	MIN	TYP	MAX	MIN	TYP	MAX	MIN	TYP	MAX	MIN	TYP	MAX	MIN	TYP	MAX	
OUTPUT VOLTAGE		3.27	3.30	3.33	4.95	5.00	5.05	11.88	12.00	12.12	14.85	15.00	15.15	17.82	18.00	18.18	VDC
OUTPUT CURRENT ¹	V _{IN} = 16 to 40 VDC	0	—	6.06	0	—	5.0	0	—	2.5	0	—	2.0	0	—	1.67	A
OUTPUT POWER ¹	V _{IN} = 16 to 40 VDC	0	—	20	0	—	25	0	—	30	0	—	30	0	—	30	W
OUTPUT RIPPLE VOLTAGE	10 kHz – 2 MHz Tc = -55°C TO +125°C	—	15	40	—	35	50	—	25	50	—	25	50	—	—	40	mV p-p
LINE REGULATION ²	V _{in} = 16 to 40 VDC Tc = -55°C TO +125°C	—	5	10	—	10	30	—	10	30	—	10	30	—	—	30	mV
LOAD REGULATION	NO LOAD TO FULL Tc = -55°C TO +125°C	—	2	10	—	5	30	—	5	30	—	5	30	—	—	30	mV
INPUT VOLTAGE ¹	CONTINUOUS	16	28	40	16	28	40	16	28	40	16	28	40	16	28	40	VDC
NO LOAD TO FULL	TRANSIENT 50 ms	—	—	50	—	—	50	—	—	50	—	—	50	—	—	50	V
INPUT CURRENT ¹	NO LOAD	—	30	75	—	35	75	—	35	75	—	35	75	—	—	50	mA
	FULL LOAD	—	0.94	—	—	1.15	—	—	1.30	—	—	1.25	—	—	1.33	—	A
	INHIBITED	—	7	8	—	3	8	—	3	8	—	3	8	—	—	8	mA
INPUT RIPPLE CURRENT	10 kHz – 10 MHz Tc = -55°C TO +125°C	—	25	50	—	20	50	—	20	50	—	20	50	—	—	50	mA p-p
EFFICIENCY		74	76	—	76	78	—	80	83	—	81	84	—	81	—	—	%
LOAD FAULT ³	SHORT CIRCUIT POWER DISSIPATION RECOVERY ^{1, 4}	—	—	10	—	—	10	—	—	10	—	—	10	—	—	10	W
		—	1.4	6	—	1.4	5	—	1.4	5	—	1.4	5	—	1.4	—	ms
STEP LOAD RESP.	50% – 100% – 50% TRANSIENT RECOVERY ⁴	—	±125	±250	—	±200	±300	—	±250	±400	—	±350	±500	—	—	±600	mV pk
		—	—	200	—	60	200	—	60	200	—	60	200	—	60	—	µs
STEP LINE RESP.	16 – 40 – 16 VDC TRANSIENT ⁵ RECOVERY ⁴	—	—	±300	—	±200	±300	—	±400	±500	—	±500	±600	—	±500	—	mV pk
		—	—	300	—	—	300	—	—	300	—	—	300	—	300	—	µs
START-UP ¹	DELAY	—	1.4	5	—	1.4	5	—	1.4	5	—	1.4	5	—	—	5	ms
	OVERSHOOT FULL LOAD	—	0	50	—	0	50	—	0	120	—	0	150	—	0	—	mV pk
	NO LOAD	—	33	150	—	50	250	—	120	600	—	150	750	—	—	—	

Notes

1. Tc = -55°C to +125°C
2. Operation is limited below 16V (see Figure 22).
3. Indefinite short circuit protection not guaranteed above 125°C case.
4. Recovery time is measured from application of the transient to point at which Vout is within 1% of final value.
5. Transition time ≥ 10 µs.

DC/DC CONVERTERS

MTR SERIES 30 WATT

Electrical Characteristics: 25°C Tc, 28 VDC Vin, 100% load, free run, unless otherwise specified.

PARAMETER	CONDITIONS	MTR2805D			MTR2812D			MTR2815D			UNITS	
		MIN	TYP	MAX	MIN	TYP	MAX	MIN	TYP	MAX		
OUTPUT VOLTAGE	+V _{OUT}	4.95	5.00	5.05	11.88	12.00	12.12	14.85	15.00	15.15	VDC	
	-V _{OUT}	4.92	5.00	5.07	11.82	12.00	12.18	14.77	15.00	15.23		
OUTPUT CURRENT ^{1, 2}	V _{IN} = 16 TO 40 VDC	0	2.5	4.5	0	1.25	2.25	0	1.0	1.8	A	
OUTPUT POWER ^{1, 2}	V _{IN} = 16 TO 40 VDC	0	—	25	0	—	30	0	—	30	W	
OUTPUT RIPPLE VOLTAGE	10 kHz - 2 MHz	—	20	50	—	30	80	—	25	80	mV p-p	
+/- V _{OUT}	Tc = -55°C TO +125°C	—	40	80	—	40	120	—	40	120		
LINE REGULATION ³ V _{IN} = 16 TO 40 VDC	+V _{OUT}	—	10	50	—	10	30	—	10	30	mV	
	-V _{OUT}	—	50	100	—	50	120	—	50	150		
	Tc = -55°C	+V _{OUT}	—	10	50	—	10	50	—	10		50
	TO +125°C	-V _{OUT}	—	50	100	—	50	150	—	50		180
LOAD REGULATION NO LOAD TO FULL	+V _{OUT}	—	5	30	—	15	30	—	15	30	mV	
	-V _{OUT}	—	25	50	—	30	120	—	30	150		
	Tc = -55°C	+V _{OUT}	—	5	50	—	15	50	—	15		50
	TO +125°C	-V _{OUT}	—	25	100	—	30	180	—	30		180
CROSS REGULATION	SEE NOTE 4	—	7	12	—	4	8.3	—	3	8	%	
EFFECT ON -V _{OUT}	SEE NOTE 5	—	4	6	—	4	6	—	4	6	%	
INPUT VOLTAGE ¹	CONTINUOUS	16	28	40	16	28	40	16	28	40	VDC	
NO LOAD TO FULL	TRANSIENT 50 ms	0	—	50	0	—	50	0	—	50	V	
INPUT CURRENT	NO LOAD	—	35	75	—	50	75	—	50	75	mA	
	FULL LOAD	—	1.10	—	—	1.34	—	—	1.29	—	A	
	INHIBITED	—	3	8	—	3	8	—	3	8	mA	
INPUT RIPPLE CURRENT ¹	10 kHz - 10 MHz	—	15	50	—	20	50	—	20	50	mA p-p	
EFFICIENCY		76	78	—	78	81	—	80	83	—	%	
LOAD FAULT ⁶	POWER DISSIPATION	—	—	10	—	—	10	—	—	10	W	
	SHORT CIRCUIT ¹ RECOVERY	—	1.4	5.0	—	1.4	5.0	—	1.4	5.0	ms	
STEP LOAD RESPONSE ± V _{OUT}	50 - 100 - 50% BALANCED TRANSIENT	—	±200	±300	—	±150	±300	—	±200	±400	mV pk	
	RECOVERY ⁷	—	100	200	—	100	200	—	100	200	µs	
STEP LINE RESPONSE ± V _{OUT}	16 - 40 - 16 V _{IN} TRANSIENT ⁸	—	±200	±400	—	±200	±400	—	±400	±500	mV pk	
	RECOVERY ⁷	—	—	300	—	—	300	—	—	300	µs	
START-UP ¹	DELAY	—	1.4	5	—	1.4	5	—	1.4	5	ms	
	OVERSHOOT	—	—	—	—	—	—	—	—	—	mV pk	
	FULL LOAD	—	0	50	—	0	120	—	0	150		
	NO LOAD	—	50	250	—	120	600	—	150	750		

Notes

- Tc = -55°C to +125°C.
- Up to 90% of the total output current/power is available from either output providing the positive output is carrying at least 10% of the total output power.
- Operation is limited below 16 V (see Figure 22).
- Effect on the negative output under the following conditions:
+P_{out} 20% to 80%; -P_{out} 80% to 20%
- Effect on the negative output under the following conditions:
+P_{out} 50%; -P_{out} 10% to 50%
- Indefinite short circuit protection not guaranteed above 125°C case.
- Recovery time is measured from application of the transient to point at which V_{out} is within 1% of final value.
- Transition time ≥ 10 µs.

MTR SERIES 30 WATT

DC/DC CONVERTERS

Electrical Characteristics: 25°C Tc, 28 VDC Vin, 100% load, free run, unless otherwise specified.

TRIPLE OUTPUT MODELS		MTR28512T			MTR28515T			UNITS	
PARAMETER	CONDITION	MIN	TYP	MAX	MIN	TYP	MAX		
OUTPUT VOLTAGE	MAIN	4.95	5.0	5.05	4.95	5.0	5.05	VDC	
	+ AUXILIARY	11.82	12.0	12.18	14.77	15.0	15.23		
	- AUXILIARY	11.82	12.0	12.18	14.77	15.0	15.23		
OUTPUT CURRENT ¹ VIN = 16 TO 40	MAIN	0.5	—	4.0	0.5	—	4.0	A	
	+ AUXILIARY	—	0.416	0.750	—	0.333	0.600		
	- AUXILIARY	—	0.416	0.750	—	0.333	0.600		
OUTPUT POWER ¹ VIN = 16 TO 40	MAIN	—	20	20	—	20	20	W	
	+ AUXILIARY	—	5	9	—	5	9		
	- AUXILIARY	—	5	9	—	5	9		
	TOTAL	—	—	30	—	—	30		
OUTPUT RIPPLE VOLTAGE	10 kHz to 2 MHz MAIN	—	50	115	—	50	115	mV p-p	
	± AUXILIARY	—	20	80	—	20	80		
LINE REGULATION VIN = 16 TO 40	MAIN	—	10	20	—	10	20	mV	
	±AUXILIARY	—	25	60	—	30	75		
LOAD REGULATION ^{2, 3}	MAIN	—	10	20	—	10	50	mV	
	± AUXILIARY	—	30	75	—	30	75		
INPUT VOLTAGE	CONTINUOUS	16	28	40	16	28	40	VDC	
	TRANSIENT 50 ms	—	—	50	—	—	50		
INPUT CURRENT	NO LOAD	—	70	100	—	70	100	mA	
	FULL LOAD	—	1.37	1.45	—	1.37	1.45	A	
	INHIBITED	—	3.0	8	—	3.0	8	mA	
INPUT RIPPLE CURRENT	10 kHz TO 10 MHz	—	20	40	—	20	40	mA p-p	
EFFICIENCY		72	75	—	73	75	—	%	
LOAD FAULT ⁴	POWER DISSIPATION SHORT CIRCUIT ALL OUTPUTS SHORTED TOTAL	—	—	14	—	—	14	W	
	RECOVERY EACH OUTPUT	—	1.4	2.0	—	1.4	2.0	ms	
	STEP LOAD RESPONSE								
STEP LOAD RESPONSE	TRANSIENT ⁵	MAIN	—	150	250	—	150	250	mV
		± AUXILIARY	—	500	750	—	500	750	
	RECOVERY ⁶	MAIN	—	0.05	0.10	—	0.05	0.10	ms
		± AUXILIARY	—	3	5	—	2	5	
STEP LINE RESPONSE VIN = 16 TO 40	TRANSIENT	MAIN	—	150	250	—	150	250	mV
		± AUXILIARY	—	100	250	—	100	250	
START-UP	DELAY	—	1.4	2.0	—	1.4	2.0	ms	
	OVERSHOOT	MAIN	—	0	500	—	0	500	mV
± AUXILIARY		—	0	1500	—	0	1500		

Notes

- The sum of the two aux outputs is not to exceed 10 watts. The maximum load per aux output is 9 watts.
- To maintain regulation when operating the ±Aux at full load, a minimum load of 500 mA is required on the main.
- Measured on each output one at a time with the other outputs at full load.
- Indefinite short circuit protection not guaranteed above 125°C (case).
- Response of each output as all outputs are simultaneously transitioned.
Main: 50% - 100% - 50% of main full load
Auxiliaries: 25% - 50% - 25% each, of total auxiliary full load
- Recovery time is measured from application of the transient to point at which Vout is within 1% of regulation.

DC/DC CONVERTERS

MTR SERIES 30 WATT

TRIM AND REMOTE SENSE (AVAILABLE ON SINGLE OUTPUT MODELS ONLY)

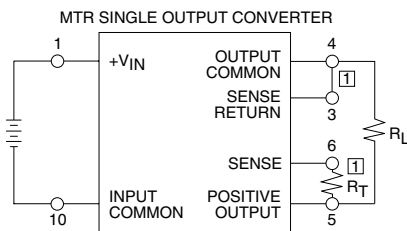

EXTERNAL TRIM CONNECTION

1 Make connections at converter.

FIGURE 1: TRIM CONNECTION^{1, 2, 3}

Trim Formulas

V_{out} = desired output voltage; R_t = trim resistor

$$3.3V: R_t = \frac{1300 * V_{out} - 4304}{1.2475}$$

$$5V: R_t = \frac{1300 * V_{out} - 6512}{1.2475}$$

$$12V: R_t = \frac{1300 * V_{out} - 15631}{1.2475}$$

$$15V: R_t = \frac{1300 * V_{out} - 19498}{1.2475}$$

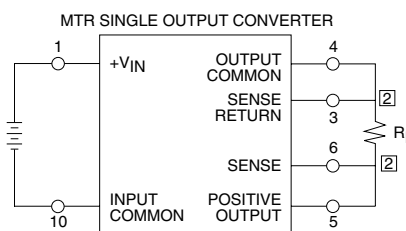

REMOTE SENSE CONNECTION

2 Make connections at load.

FIGURE 2: REMOTE SENSE^{2, 3}

Notes for Remote Sense and Trim

1. When trimming output voltage and/or remote sensing, the total output voltage increase must be less than 0.6 volts at the converters pins to maintain specified performance.
2. If neither voltage trim nor remote sense will be used, connect pin 3 to pin 4 and pin 5 to pin 6 or the output voltage will increase by 1.2 volts.
3. CAUTION: The converter will be permanently damaged if the positive remote sense (pin 6) is shorted to ground. Damage may also result if the output common or positive output is disconnected from the load with the remote sense leads connected to the load.

PIN OUT

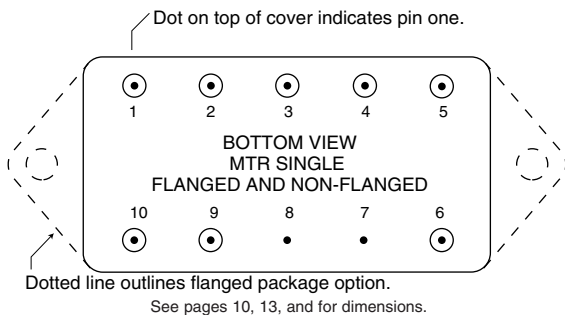

FIGURE 3: PIN OUT SINGLE OUTPUT MODELS

Pin	Single Output	Dual Output	Triple Output
1	Positive Input	Positive Input	Positive Input
2	Inhibit	Inhibit	Main (+5) Output
3	Sense Return	Positive Output	Output Common
4	Output Common	Output Common	Neg. Aux. Output
5	Positive Output	Negative Output	Pos. Aux. Output
6	Positive Sense	Case Ground	Case Ground
7	Case Ground	Case Ground	Case Ground
8	Case Ground	Case Ground	Inhibit
9	Sync	Sync	Sync
10	Input Common	Input Common	Input Common

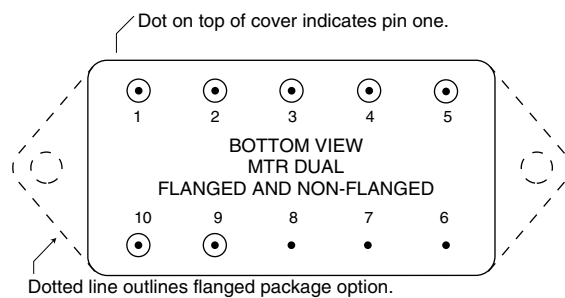

FIGURE 4: PIN OUT DUAL OUTPUT MODELS

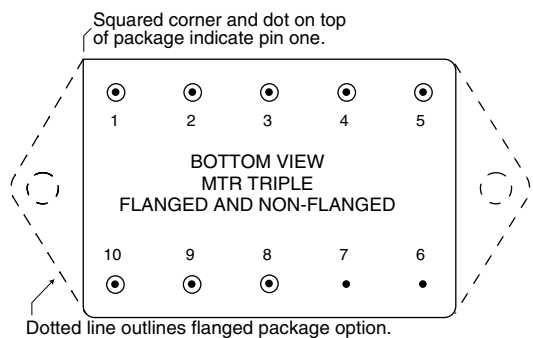

FIGURE 5: PIN OUT TRIPLE OUTPUT MODELS

MTR SERIES 30 WATT

DC/DC CONVERTERS

SMD NUMBERS

STANDARD MICROCIRCUIT DRAWING (SMD)	MTR SERIES SIMILAR PART
5962-0150101HXC	MTR283R3S/883
5962-9306801HXC	MTR2805S/883
5962-9306901HXC	MTR2812S/883
5962-9307001HXC	MTR2815S/883
5962-9320201HXC	MTR2818S/883
5962-9320501HXC	MTR2805D/883
5962-9307101HXC	MTR2812D/883
5962-9307201HXC	MTR2815D/883
5962-9307301HXC	MTR28512T/883
5962-9307401HXC	MTR28515T/883

To indicate the flanged case option change the "X" to "Z" in the SMD number. The SMD number shown is for Class H screening, non-flanged. For exact specifications for an SMD product, refer to the SMD drawing. SMDs can be downloaded from: <http://www.dscc.dla.mil/programs/smcr>

MODEL NUMBERING KEY

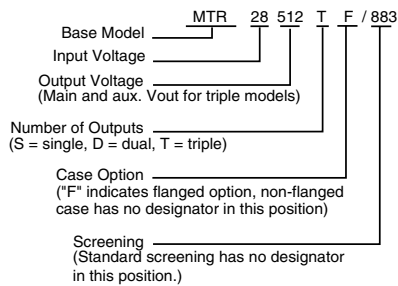

Typical Performance Curves: 25°C Tc, 28 VDC Vin, 100% load, free run, unless otherwise specified.

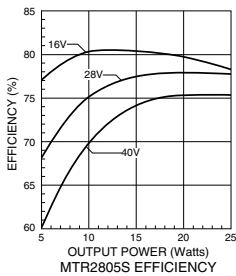

FIGURE 6

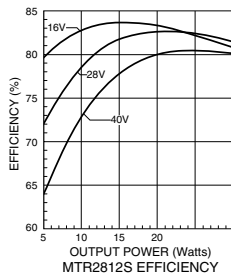

FIGURE 7

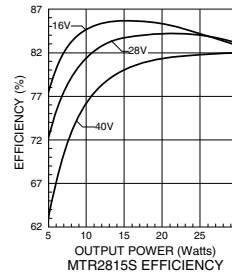

FIGURE 8

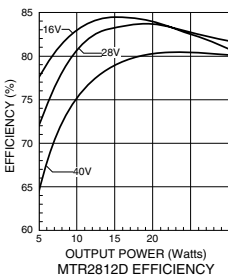

FIGURE 9

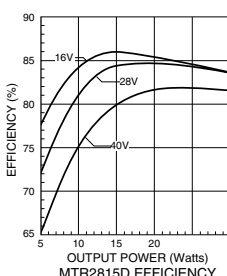

FIGURE 10

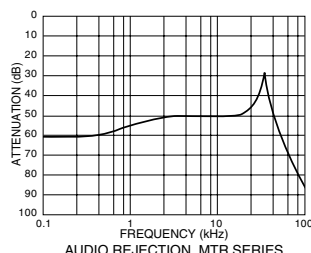
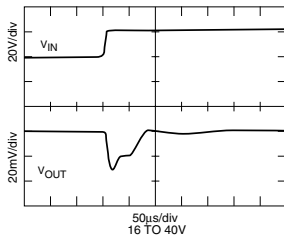

FIGURE 11

DC/DC CONVERTERS

MTR SERIES 30 WATT

Typical Performance Curves: 25°C Tc, 28 VDC Vin, 100% load, free run, unless otherwise specified.



MTR2805S STEP LINE RESPONSE

FIGURE 12

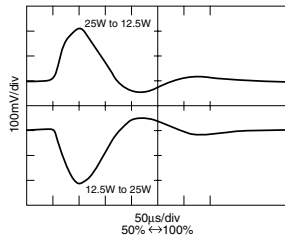

MTR2805S STEP LOAD RESPONSE

FIGURE 13

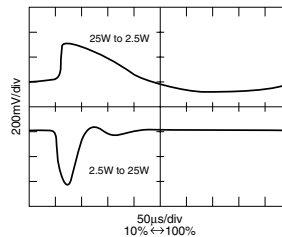

MTR2805S STEP LOAD RESPONSE

FIGURE 14

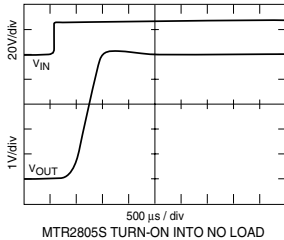

MTR2805S TURN-ON INTO NO LOAD

FIGURE 15

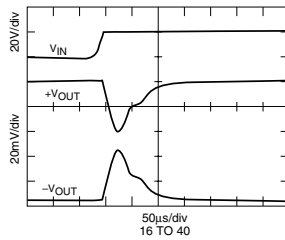

MTR2815D STEP LINE RESPONSE

FIGURE 16

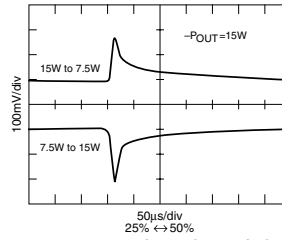

MTR2815D +VOUT STEP LOAD RESPONSE

FIGURE 17

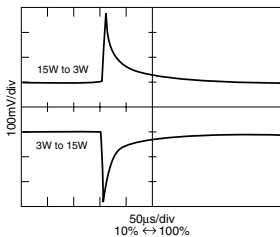

MTR2815D +VOUT STEP LOAD RESPONSE

FIGURE 18

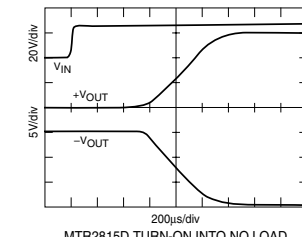

MTR2815D TURN-ON INTO NO LOAD

FIGURE 19

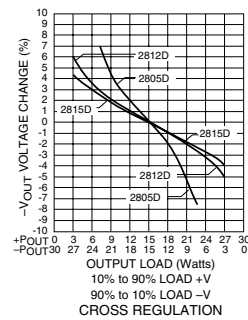
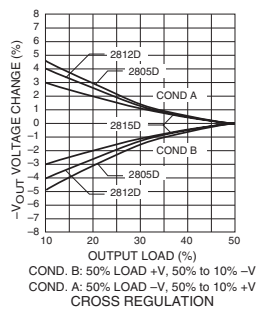
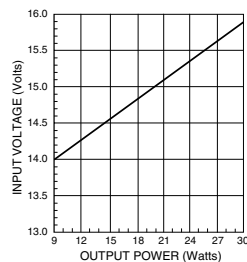

FIGURE 20



COND. B: 50% LOAD +V, 50% to 10% -V
COND. A: 50% LOAD -V, 50% to 10% +V
CROSS REGULATION

FIGURE 21



1% DROP
MTR SINGLES AND DUALS
LOW LINE DROPOUT

FIGURE 22

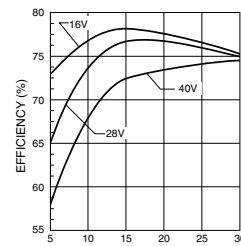

FIGURE 23

MTR SERIES 30 WATT

DC/DC CONVERTERS

Typical Performance Curves: 25°C Tc, 28 VDC Vin, 100% load, free run, unless otherwise specified.

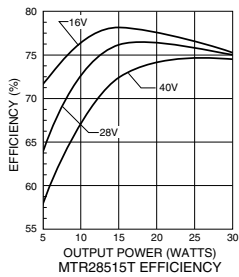

FIGURE 24

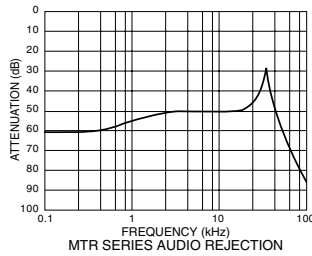

FIGURE 25

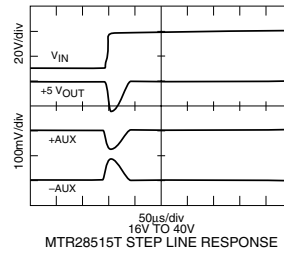

FIGURE 26

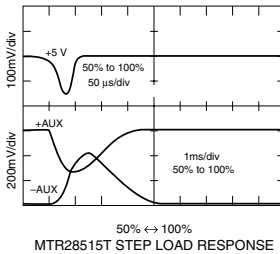

FIGURE 27

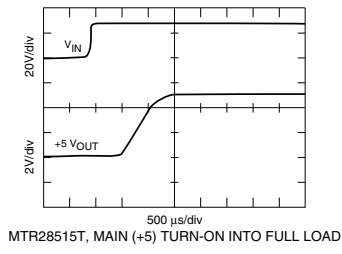

FIGURE 28

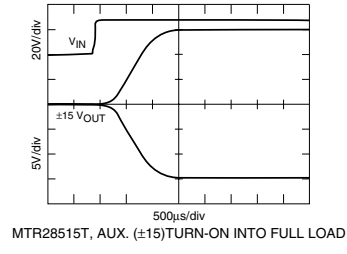

FIGURE 29

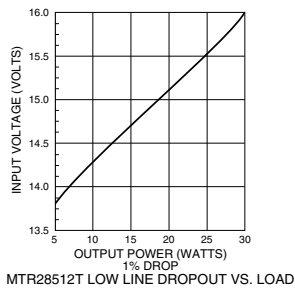

FIGURE 30

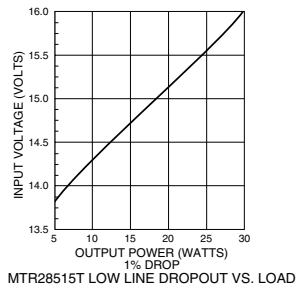
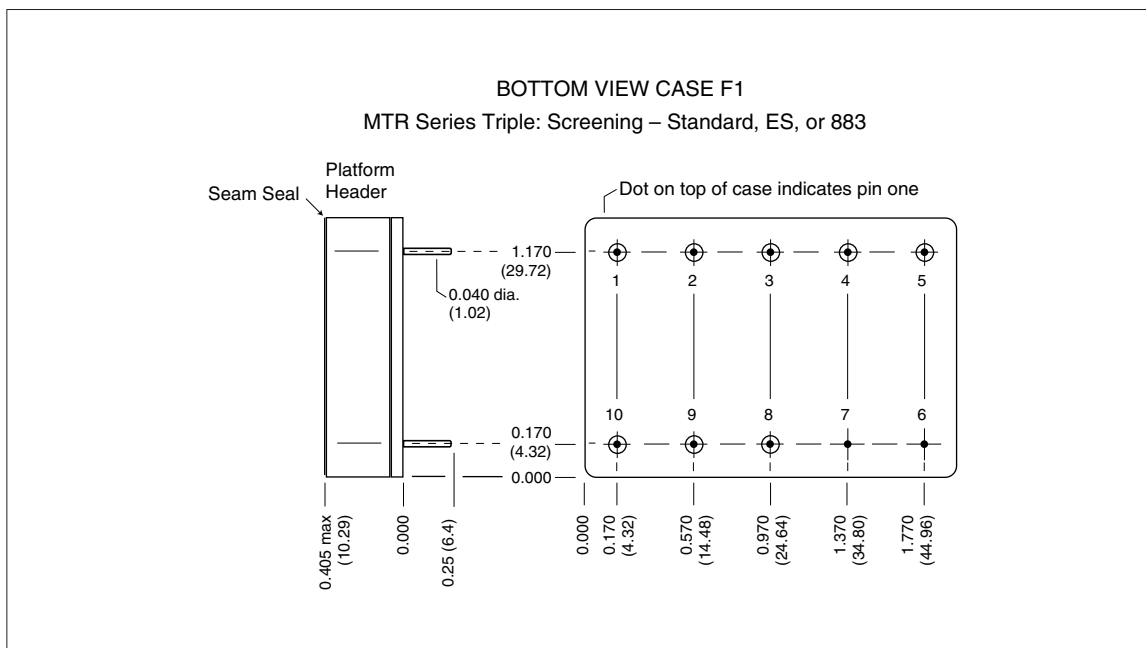
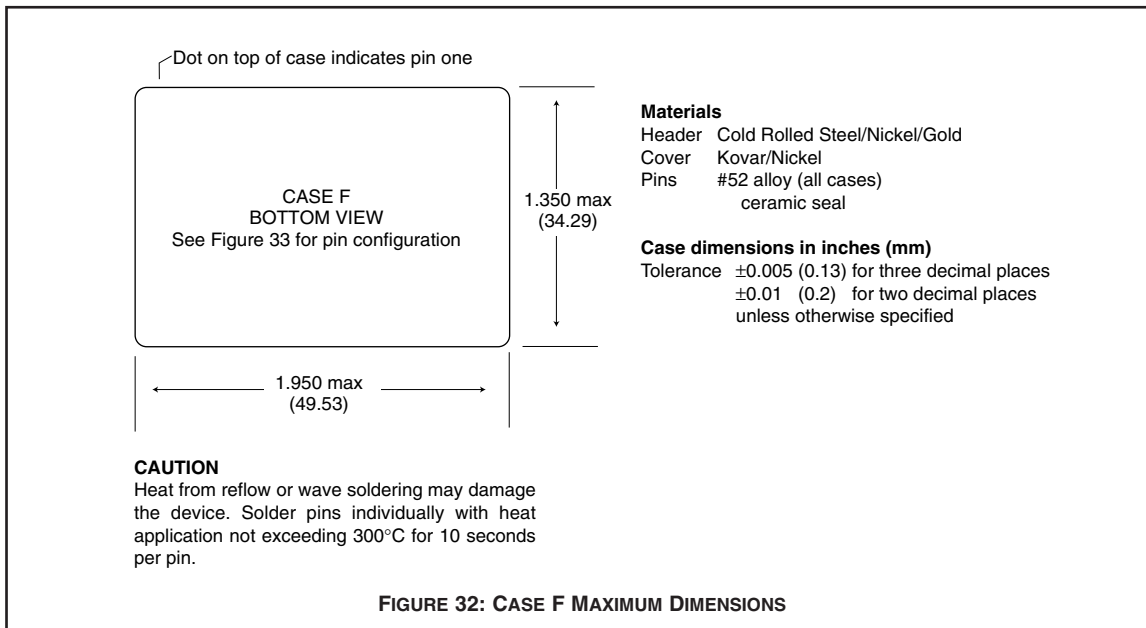

FIGURE 31

DC/DC CONVERTERS

MTR SERIES 30 WATT



Note: Although every effort has been made to render the case drawings at actual size, variations in the printing process may cause some distortion. Please refer to the numerical dimensions for accuracy.

MTR SERIES 30 WATT

DC/DC CONVERTERS

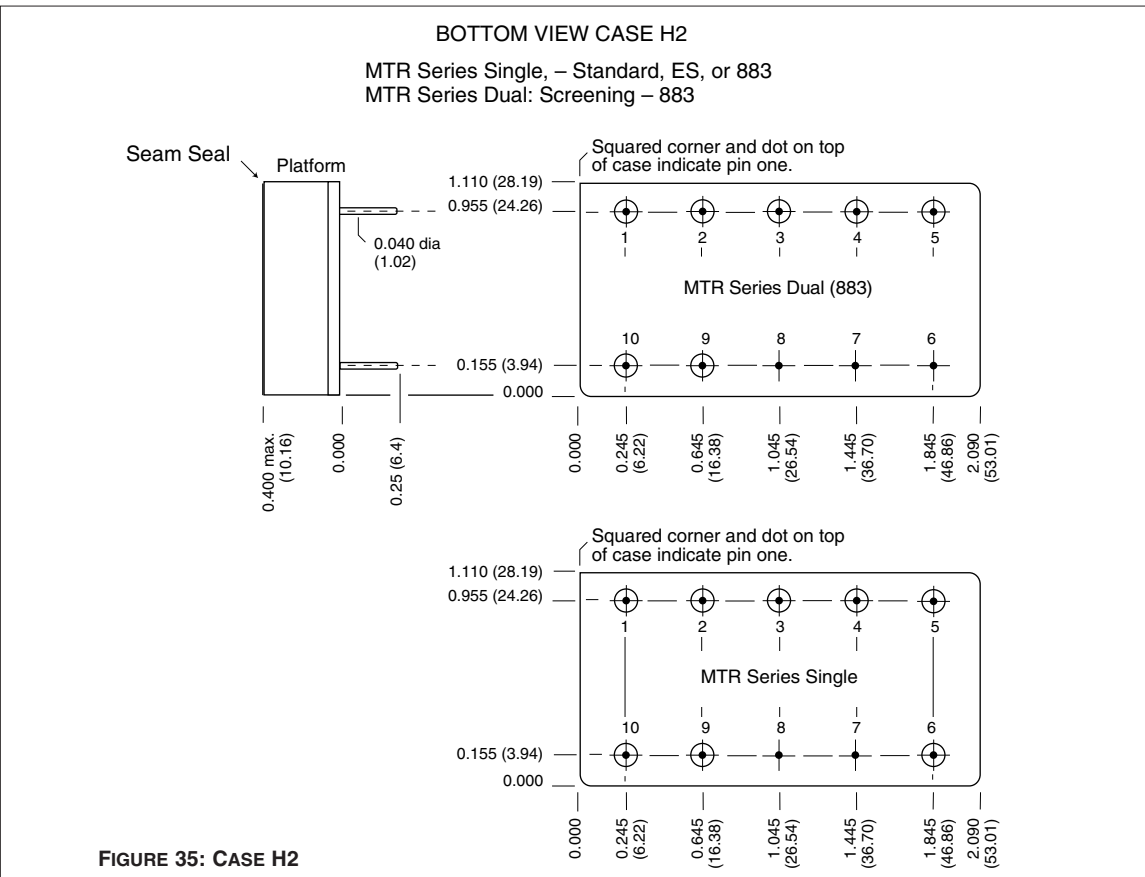
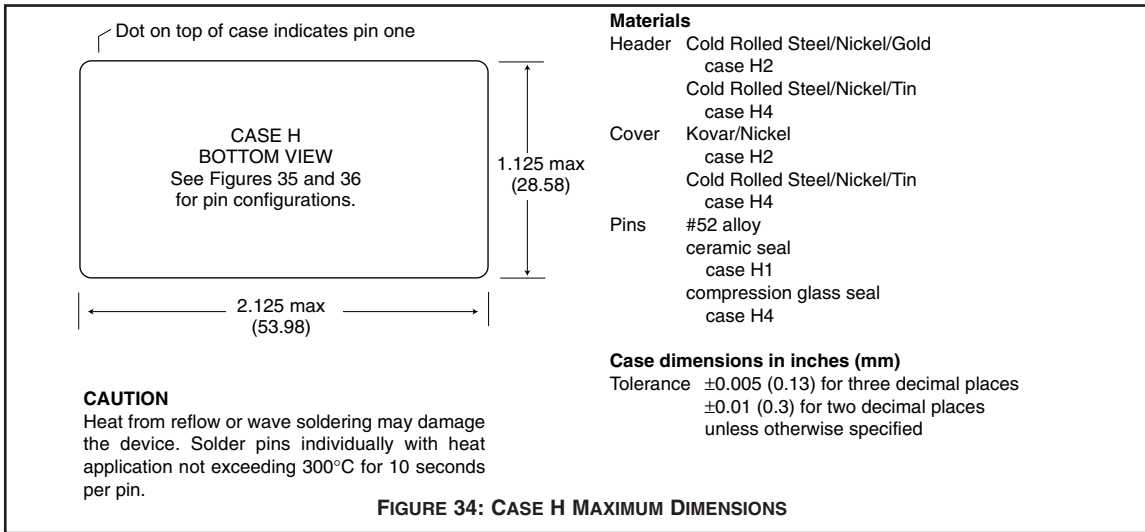

DC/DC CONVERTERS

MTR SERIES 30 WATT

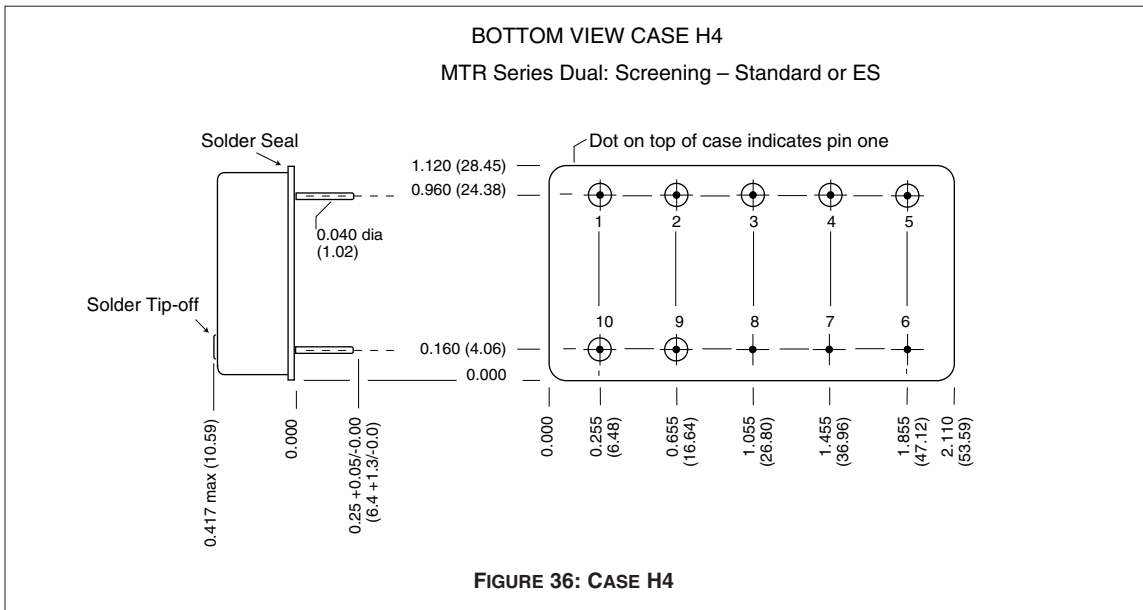

MTR SERIES
30 WATT

DC/DC CONVERTERS

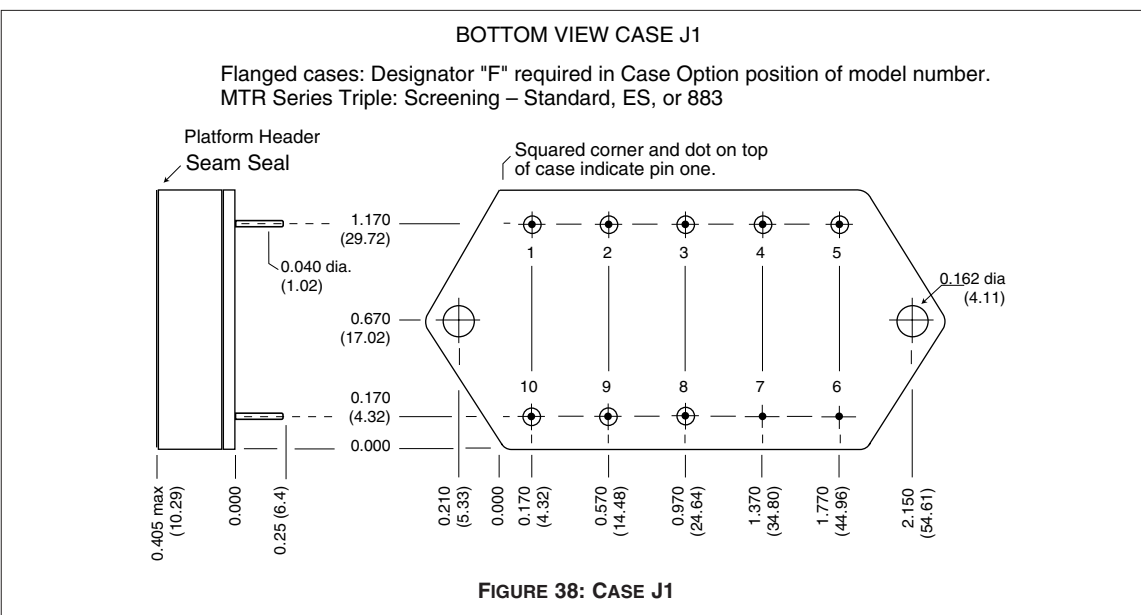
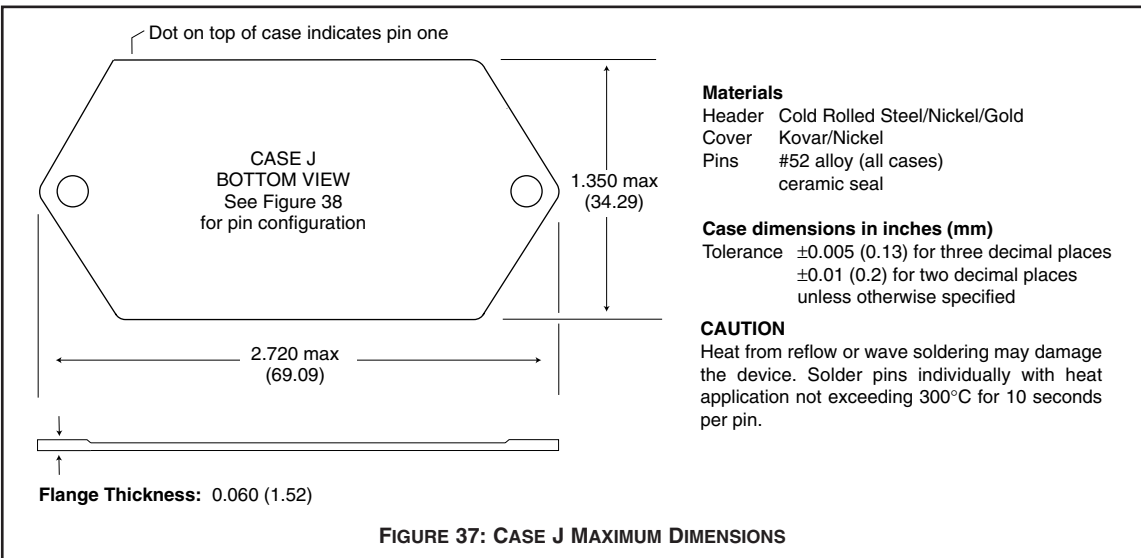

DC/DC CONVERTERS

MTR SERIES 30 WATT

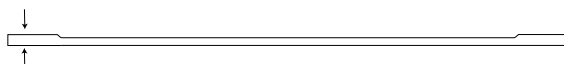
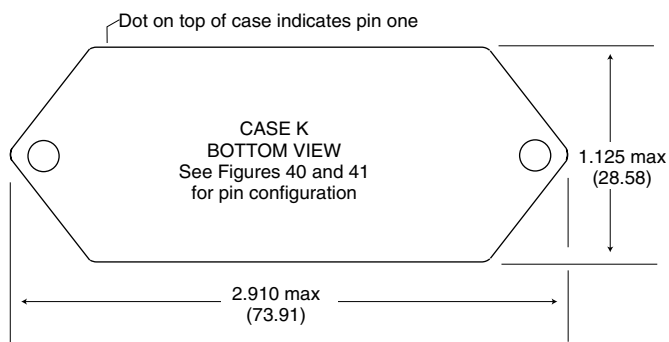

Flange Thickness:

- Case K3 0.060 (1.52)
- Case K5 0.067 +0.005/-0.007 (1.70 +0.13/-0.8)

Materials

- Header Case K3
Cold Rolled Steel/Nickel/Gold
- Case K8
Cold Rolled Steel/Nickel/Tin
- Cover Case K3
Kovar/Nickel
- Case K8
Cold Rolled Steel/Nickel/Tin
- Pins #52 alloy (all cases)
- Case K3
ceramic seal
- Case K8
compression glass seal

Case dimensions in inches (mm)

- Tolerance ± 0.005 (0.13) for three decimal places
- ± 0.01 (0.2) for two decimal places
- unless otherwise specified

CAUTION

Heat from reflow or wave soldering may damage the device. Solder pins individually with heat application not exceeding 300°C for 10 seconds per pin.

FIGURE 39: CASE K MAXIMUM DIMENSIONS

DC/DC CONVERTERS

MTR SERIES 30 WATT

Figure 40 continued: BOTTOM VIEW CASE K3

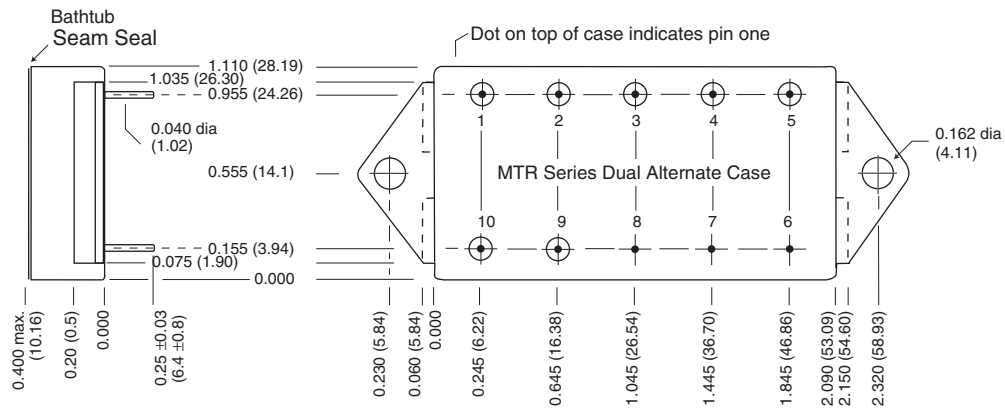
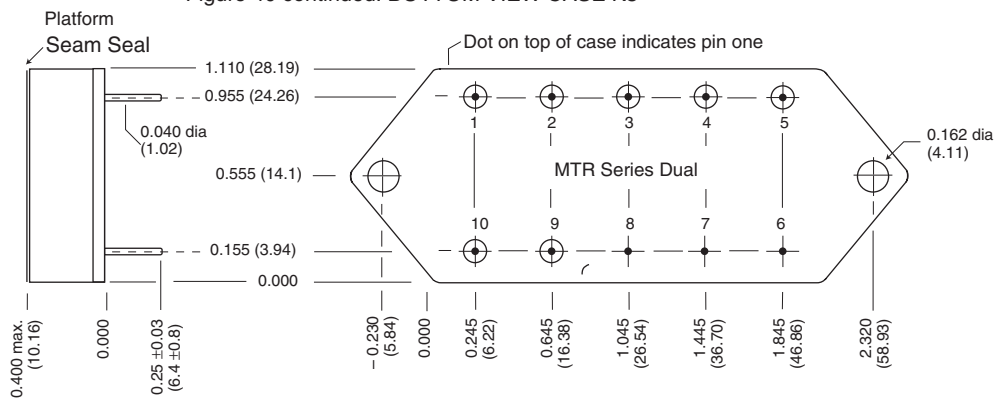

FIGURE 40: CASE K3 CONTINUED

BOTTOM VIEW CASE K5

Flanged cases: Designator "F" required in Case Option position of model number.
MTR Series Dual: Screening – Standard or ES

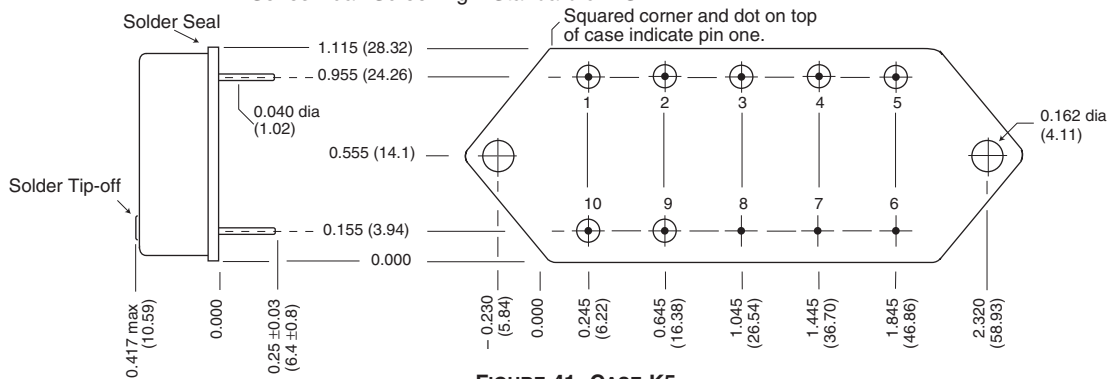

FIGURE 41: CASE K5

**MTR SERIES
30 WATT**

DC/DC CONVERTERS

ENVIRONMENTAL SCREENING

TEST	STANDARD	/ES	/883 (Class H)*
PRE-CAP INSPECTION Method 2017, 2032	yes	yes	yes
TEMPERATURE CYCLE (10 times) Method 1010, Cond. C, -65°C to 150°C Method 1010, Cond. B, -55°C to 125°C	no no	no yes	yes no
CONSTANT ACCELERATION Method 2001, 3000 g Method 2001, 500 g	no no	no yes	yes no
BURN-IN Method 1015, 160 hours at 125°C 96 hours at 125°C case (typical)	no no	no yes	yes no
FINAL ELECTRICAL TEST MIL-PRF-38534, Group A Subgroups 1 through 6: -55°C, +25°C, +125°C Subgroups 1 and 4: +25°C case	no yes	no yes	yes no
HERMETICITY TESTING Fine Leak, Method 1014, Cond. A Gross Leak, Method 1014, Cond. C Gross Leak, Dip (1 x 10 ⁻³)	no no yes	yes yes no	yes yes no
FINAL VISUAL INSPECTION Method 2009	yes	yes	yes

Test methods are referenced to MIL-STD-883 as determined by MIL-PRF-38534.

*883 products are built with element evaluated components and are 100% tested and guaranteed over the full military temperature range of -55°C to +125°C.

Contact Information:

www.interpoint.com

Interpoint Headquarters USA
Phone: 1-800-822-8782
+425-882-3100
Email: power@intp.com

Interpoint UK
Phone: +44-1252-815511
Email: poweruk@intp.com

Interpoint France
Phone: +33-134285455
Email: powerfr@intp.com