

### Smart Highside High Current Power Switch

#### Features

- Overload protection
- Current limitation
- Short circuit protection
- Overtemperature protection
- Overvoltage protection (including load dump)
- Clamp of negative voltage at output
- Fast deenergizing of inductive loads <sup>1)</sup>
- Low ohmic inverse current operation
- Reverse battery protection
- Diagnostic feedback with load current sense
- Open load detection via current sense
- Loss of  $V_{bb}$  protection<sup>2)</sup>
- **Electrostatic discharge (ESD)** protection

#### Product Summary

Overvoltage protection	$V_{bb(AZ)}$	70	V
Output clamp	$V_{ON(CL)}$	60	V
Operating voltage	$V_{bb(on)}$	5.0 ... 55	V
On-state resistance	$R_{ON}$	9	m $\Omega$
Load current (ISO)	$I_L(ISO)$	44	A
Short circuit current limitation	$I_L(SCp)$	145	A
Current sense ratio	$I_L : I_{IS}$	13 000	

#### Application

- Power switch with current sense diagnostic feedback for up to 48V DC grounded loads
- Most suitable for loads with high inrush current like lamps and motors; all types of resistive and inductive loads
- Replaces electromechanical relays, fuses and discrete circuits

TO-220AB/7

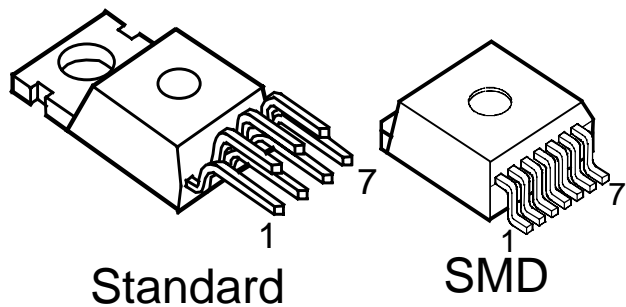

#### General Description

N channel vertical power FET with charge pump, current controlled input and diagnostic feedback with load current sense, integrated in Smart SIPMOS<sup>®</sup> chip on chip technology. Fully protected by embedded protection functions.

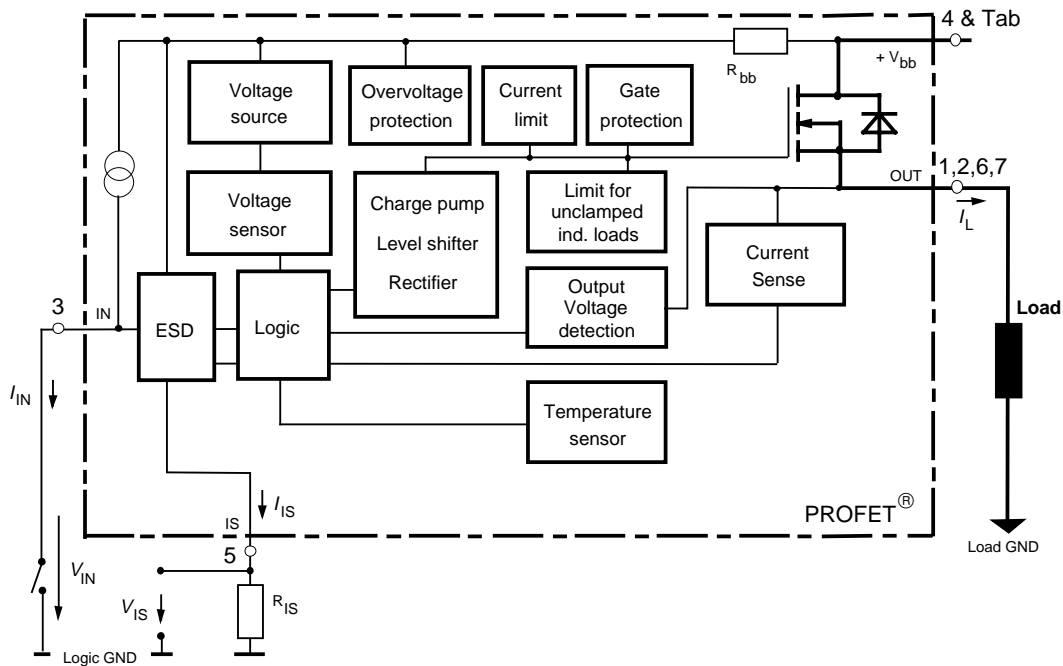

<sup>1)</sup> With additional external diode.

<sup>2)</sup> Additional external diode required for energized inductive loads (see page 9).

Pin	Symbol		Function
1	OUT	O	Output to the load. The pins 1,2,6 and 7 must be shorted with each other especially in high current applications! <sup>3)</sup>
2	OUT	O	Output to the load. The pins 1,2,6 and 7 must be shorted with each other especially in high current applications! <sup>3)</sup>
3	IN	I	Input, activates the power switch in case of short to ground
4	V <sub>bb</sub>	+	Positive power supply voltage, the tab is electrically connected to this pin. In high current applications the tab should be used for the V <sub>bb</sub> connection instead of this pin <sup>4)</sup> .
5	IS	S	Diagnostic feedback providing a sense current proportional to the load current; zero current on failure (see Truth Table on page 7)
6	OUT	O	Output to the load. The pins 1,2,6 and 7 must be shorted with each other especially in high current applications! <sup>3)</sup>
7	OUT	O	Output to the load. The pins 1,2,6 and 7 must be shorted with each other especially in high current applications! <sup>3)</sup>

### Maximum Ratings at $T_j = 25\text{ °C}$ unless otherwise specified

Parameter	Symbol	Values	Unit
Supply voltage (overvoltage protection see page 4)	V <sub>bb</sub>	60	V
Supply voltage for full short circuit protection, resistive load or $L < \text{tbd } \mu\text{H}$ $T_{j,\text{start}} = -40 \dots +150\text{ °C}$ :	V <sub>bb</sub>	55	V
Load current (short circuit current, see page 5)	I <sub>L</sub>	self-limited	A
Load dump protection $V_{\text{LoadDump}} = U_A + V_S$ , $U_A = 13.5\text{ V}$ $R_l^5) = 2\ \Omega$ , $R_L = 0.23\ \Omega$ , $t_d = 200\ \text{ms}$ , IN, IS = open or grounded	V <sub>Load dump</sub> <sup>6)</sup>	80	V
Operating temperature range	T <sub>j</sub>	-40 ... +150	°C
Storage temperature range	T <sub>stg</sub>	-55 ... +150	
Power dissipation (DC), $T_C \leq 25\text{ °C}$	P <sub>tot</sub>	170	W
Inductive load switch-off energy dissipation, single pulse $V_{bb} = 12\text{ V}$ , $T_{j,\text{start}} = 150\text{ °C}$ , $T_C = 150\text{ °C}$ const., $I_L = 20\ \text{A}$ , $Z_L = \text{tbd}$ mH, $0\ \Omega$ , see diagrams on page 10	E <sub>AS</sub>	tbd (>1.2)	J
Electrostatic discharge capability (ESD) Human Body Model acc. MIL-STD883D, method 3015.7 and ESD assn. std. S5.1-1993, C = 100 pF, R = 1.5 kΩ	V <sub>ESD</sub>	2.0	kV
Current through input pin (DC)	I <sub>IN</sub>	+15, -250	mA
Current through current sense status pin (DC) see internal circuit diagrams on page 7 and 8	I <sub>IS</sub>	+15, -250	

<sup>3)</sup> Not shorting all outputs will considerably increase the on-state resistance, reduce the peak current capability and decrease the current sense accuracy

<sup>4)</sup> Otherwise add up to 0.7 mΩ (depending on used length of the pin) to the R<sub>ON</sub> if the pin is used instead of the tab.

<sup>5)</sup> R<sub>l</sub> = internal resistance of the load dump test pulse generator.

<sup>6)</sup> V<sub>Load dump</sub> is setup without the DUT connected to the generator per ISO 7637-1 and DIN 40839.



### Thermal Characteristics

Parameter and Conditions	Symbol	Values			Unit
		min	typ	max	
Thermal resistance chip - case: junction - ambient (free air): SMD version, device on PCB <sup>8)</sup> :	$R_{thJC}^{7)}$	--	--	0.75	K/W
	$R_{thJA}$	--	60	--	
				33	

### Electrical Characteristics

Parameter and Conditions at $T_j = -40 \dots +150^\circ\text{C}$ , $V_{bb} = 12\text{V}$ unless otherwise specified	Symbol	Values			Unit
		min	typ	max	

### Load Switching Capabilities and Characteristics

On-state resistance (Tab to pins 1,2,6,7, see measurement circuit page 7) $I_L = 20\text{A}$ , $T_j = 25^\circ\text{C}$ : $V_{IN} = 0$ , $I_L = 20\text{A}$ , $T_j = 150^\circ\text{C}$ : $I_L = 80\text{A}$ , $T_j = 150^\circ\text{C}$ :	$R_{ON}$	--	7.2 14.6 --	9 17 17	mΩ
Nominal load current <sup>9)</sup> (Tab to pins 1,2,6,7) ISO 10483-1/6.7: $V_{ON} = 0.5\text{V}$ , $T_C = 85^\circ\text{C}$ <sup>10)</sup>	$I_{L(ISO)}$	38	44	--	A
Nominal load current <sup>9)</sup> , device on PCB <sup>8)</sup> $T_A = 85^\circ\text{C}$ , $T_j \leq 150^\circ\text{C}$ $V_{ON} \leq 0.5\text{V}$ ,	$I_{L(NOM)}$	9.9	11.1	--	A
Maximum load current in resistive range (Tab to pins 1,2,6,7) $V_{ON} = 1.8\text{V}$ , $T_C = 25^\circ\text{C}$ : see diagram on page 12 $V_{ON} = 1.8\text{V}$ , $T_C = 150^\circ\text{C}$ :	$I_{L(Max)}$	185 105	-- --	-- --	A
Turn-on time <sup>11)</sup> $I_{IN}$  to 90% $V_{OUT}$ :	$t_{on}$	80	--	320	μs
Turn-off time $I_{IN}$  to 10% $V_{OUT}$ : $R_L = 1\Omega$ , $T_j = -40\dots+150^\circ\text{C}$	$t_{off}$	30	--	110	
Slew rate on <sup>11)</sup> (10 to 30% $V_{OUT}$ ) $R_L = 1\Omega$	$dV/dt_{on}$	--	0.8	--	V/μs
Slew rate off <sup>11)</sup> (70 to 40% $V_{OUT}$ ) $R_L = 1\Omega$	$-dV/dt_{off}$	--	0.7	--	V/μs

<sup>7)</sup> Thermal resistance  $R_{thCH}$  case to heatsink (about 0.5 ... 0.9 K/W with silicone paste) not included!

<sup>8)</sup> Device on 50mm\*50mm\*1.5mm epoxy PCB FR4 with 6cm<sup>2</sup> (one layer, 70μm thick) copper area for  $V_{bb}$  connection. PCB is vertical without blown air.

<sup>9)</sup> Not tested, specified by design.

<sup>10)</sup>  $T_j$  is about 105°C under these conditions.

<sup>11)</sup> See timing diagram on page 14.

### Inverse Load Current Operation

On-state resistance (Pins 1,2,6,7 to pin 4) $V_{bIN} = 12\text{ V}$ , $I_L = -20\text{ A}$ see diagram on page 10	$T_j = 25\text{ °C}$ : $T_j = 150\text{ °C}$ :	$R_{ON(inv)}$	--	7.2 14.6	9 17	mΩ
Nominal inverse load current (Pins 1,2,6,7 to Tab) $V_{ON} = -0.5\text{ V}$ , $T_C = 85\text{ °C}^{10}$		$I_{L(inv)}$	50	60	--	A
Drain-source diode voltage ( $V_{out} > V_{bb}$ ) $I_L = -20\text{ A}$ , $I_{IN} = 0$ , $T_j = +150\text{ °C}$		$-V_{ON}$	--	tbd	--	mV

### Operating Parameters

Operating voltage ( $V_{IN} = 0$ ) <sup>12)</sup>		$V_{bb(on)}$	5.0	--	55	V
Undervoltage shutdown <sup>13)</sup>		$V_{bIN(u)}$	--	3.5	--	V
Undervoltage start of charge pump see diagram page 15		$V_{bIN(ucp)}$	--	5	6.5	V
Overvoltage protection <sup>14)</sup> $I_{bb} = 15\text{ mA}$	$T_j = -40\text{ °C}$ : $T_j = 25\text{...}+150\text{ °C}$ :	$V_{bIN(z)}$	68 70	-- 74	-- --	V
Standby current $I_{IN} = 0$	$T_j = -40\text{...}+25\text{ °C}$ : $T_j = 150\text{ °C}$ :	$I_{bb(off)}$	-- --	-- --	25 50	μA

<sup>12)</sup> For all voltages 0 ... 55 V the device is fully protected against overtemperature and short circuit.

<sup>13)</sup>  $V_{bIN} = V_{bb} - V_{IN}$  see diagram on page 7. When  $V_{bIN}$  increases from less than  $V_{bIN(u)}$  up to  $V_{bIN(ucp)} = 5\text{ V}$  (typ.) the charge pump is not active and  $V_{OUT} \approx V_{bb} - 3\text{ V}$ .

<sup>14)</sup> See also  $V_{ON(CL)}$  in circuit diagram on page 9.

Parameter and Conditions at $T_j = -40 \dots +150^\circ\text{C}$ , $V_{bb} = 12\text{V}$ unless otherwise specified	Symbol	Values			Unit
		min	typ	max	

### Protection Functions

Short circuit current limit (Tab to pins 1,2,6,7) $V_{ON} = 12\text{V}$ , time until shutdown max. $300\ \mu\text{s}$ $T_C = -40^\circ\text{C}$ : see diagram page 8 $T_C = 25^\circ\text{C}$ : $T_C = +150^\circ\text{C}$ :	$I_{L(SCpeak)}$ $I_{L(SC)}$ $I_{L(SC)}$	-- tbd tbd	170 145 120	-- tbd tbd	A
Short circuit shutdown delay after input current positive slope, $V_{ON} > V_{ON(SC)}$ min. value valid only if input "off-signal" time exceeds $30\ \mu\text{s}$	$t_{d(SC)}$	80	--	300	$\mu\text{s}$
Output clamp <sup>15)</sup> (inductive load switch off) see diagram Ind. and overvolt. output clamp page 8 (typ. $I_{IS} = -120\ \mu\text{A}$ )	$-V_{OUT(CL)}$	-- --	15 17	-- --	V
Output clamp (inductive load switch off) at $V_{OUT} = V_{bb} - V_{ON(CL)}$ (e.g. overvoltage) $I_L = 40\ \text{mA}$	$V_{ON(CL)}$	60	64	68	V
Short circuit shutdown detection voltage (pin 4 to pins 1,2,6,7)	$V_{ON(SC)}$	--	6	--	V
Thermal overload trip temperature	$T_{jt}$	150	--	--	$^\circ\text{C}$
Thermal hysteresis	$\Delta T_{jt}$	--	10	--	K

### Reverse Battery

Reverse battery voltage <sup>16)</sup>	$-V_{bb}$	--	--	42	V
On-state resistance (Pins 1,2,6,7 to pin 4) $V_{bb} = -12\text{V}$ , $V_{IN} = 0$ , $I_L = -20\text{A}$ , $R_{IS} = 1\ \text{k}\Omega$	$R_{ON(rev)}$	--	8.8 --	10.5 20	$\text{m}\Omega$
Integrated resistor in $V_{bb}$ line	$R_{bb}$	--	tbd	--	$\Omega$

<sup>15)</sup> This output clamp can be "switched off" by using an additional diode at the IS-Pin (see page 8). If the diode is used,  $V_{OUT}$  is clamped to  $V_{bb} - V_{ON(CL)}$  at inductive load switch off.

<sup>16)</sup> The reverse load current through the intrinsic drain-source diode has to be limited by the connected load (as it is done with all polarity symmetric loads). Note that under off-conditions ( $I_{IN} = I_{IS} = 0$ ) the power transistor is not activated. This results in raised power dissipation due to the higher voltage drop across the intrinsic drain-source diode. The temperature protection is not active during reverse current operation! Increasing reverse battery voltage capability is simply possible as described on page 9.

Parameter and Conditions at $T_j = -40 \dots +150^\circ\text{C}$ , $V_{bb} = 12\text{V}$ unless otherwise specified	Symbol	Values			Unit
		min	typ	max	

### Diagnostic Characteristics

Current sense ratio, static on-condition, $k_{ILIS} = I_L : I_{IS}$ , $V_{ON} < 1.5\text{V}^{17)}$ , $V_{IS} < V_{OUT} - 5\text{V}$ , $V_{bIN} > 4.0\text{V}$ see diagram on page 12	$I_L = 80\text{A}$ , $T_j = -40^\circ\text{C}$ :	$k_{ILIS}$	11400	13 000	15400	
	$T_j = 25^\circ\text{C}$ :		11400	13 000	14600	
	$T_j = 150^\circ\text{C}$ :		11800	13 000	14200	
	$I_L = 20\text{A}$ , $T_j = -40^\circ\text{C}$ :		11000	13 000	16000	
	$T_j = 25^\circ\text{C}$ :		11000	13 000	15000	
	$T_j = 150^\circ\text{C}$ :		11500	13 000	14500	
	$I_L = 10\text{A}$ , $T_j = -40^\circ\text{C}$ :		10500	13 000	17000	
	$T_j = 25^\circ\text{C}$ :		10500	13 000	15500	
	$T_j = 150^\circ\text{C}$ :		11000	13 000	15000	
	$I_L = 4\text{A}$ , $T_j = -40^\circ\text{C}$ :		10500	13 000	19000	
$T_j = 25^\circ\text{C}$ :	10500	13 000	17000			
$T_j = 150^\circ\text{C}$ :	11000	13 000	16000			
$I_{IN} = 0$ , $I_{IS} = 0$ (e.g. during deenergizing of inductive loads):		--	--	--		
Sense current saturation	$I_{IS,lim}$	6.5	--	--	mA	
Current sense leakage current $I_{IN} = 0$ , $V_{IS} = 0$ :	$I_{S(LL)}$	--	--	0.5	$\mu\text{A}$	
	$V_{IN} = 0$ , $V_{IS} = 0$ , $I_L \leq 0$ :	$I_{S(LH)}$	--	2	--	
Current sense overvoltage protection $T_j = -40^\circ\text{C}$ : $I_{bb} = 15\text{mA}$ $T_j = 25 \dots +150^\circ\text{C}$ :	$V_{bIS(Z)}$	68	--	--	V	
		70	74	--		
Current sense settling time <sup>18)</sup> after positive input slope (90% of $I_{IS}$ static) $I_L = 0/20\text{A}$ :	$t_{son(IS)}$	--	tbd	500	$\mu\text{s}$	
Current sense settling time <sup>18)</sup> after negative input slope (10% of $I_{IS}$ static) $I_L = 20/0\text{A}$ :	$t_{soff(IS)}$	--	tbd	500	$\mu\text{s}$	
Current sense settling time <sup>18)</sup> after change of load current (60% to 90%) $I_L = 15/20\text{A}$ :	$t_{slc(IS)}$	--	tbd	500	$\mu\text{s}$	

### Input

Input and operating current (see diagram page 13) $I_{IN}$ grounded ( $V_{IN} = 0$ )	$I_{IN(on)}$	--	1	2	mA
Input current for turn-off <sup>19)</sup>	$I_{IN(off)}$	--	--	40	$\mu\text{A}$

<sup>17)</sup> If  $V_{ON}$  is higher, the sense current is no longer proportional to the load current due to sense current saturation, see  $I_{IS,lim}$ .

<sup>18)</sup> Not tested, specified by design.

<sup>19)</sup> We recommend the resistance between IN and GND to be less than 0.5 k $\Omega$  for turn-on and more than 500k $\Omega$  for turn-off. Consider that when the device is switched off ( $I_{IN} = 0$ ) the voltage between IN and GND reaches almost  $V_{bb}$ .

### Truth Table

	Input current level	Output level	Current Sense $I_{IS}$	Remark
Normal operation	L H	L H	0 nominal	$=I_L / k_{IIS}$ , up to $I_{IS}=I_{IS,lim}$
Very high load current	H	H	$I_{IS,lim}$	up to $V_{ON}=V_{ON(Fold\ back)}$ $I_{IS}$ no longer proportional to $I_L$
Current-limitation	H	H	0	$V_{ON} > V_{ON(Fold\ back)}$ if $V_{ON} > V_{ON(SC)}$ , shutdown will occur
Short circuit to GND	L H	L L	0 0	
Over-temperature	L H	L L	0 0	
Short circuit to $V_{bb}$	L H	H H	0 <nominal <sup>20)</sup>	
Open load	L H	Z <sup>21)</sup> H	0 0	
Negative output voltage clamp	L	L	0	
Inverse load current	L H	H H	0 0	

L = "Low" Level

H = "High" Level

Overtemperature reset by cooling:  $T_j < T_{jt}$  (see diagram on page 15)

Short circuit to GND: Shutdown remains latched until next reset via input (see diagram on page 14)

### Terms

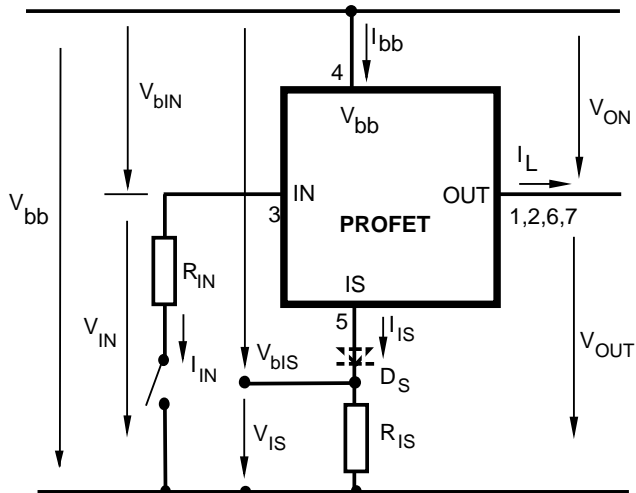

Two or more devices can easily be connected in parallel to increase load current capability.

### RON measurement layout

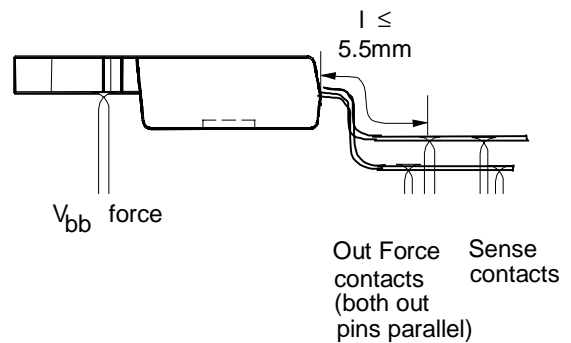

Typical RON for SMD version is about 0.2 mΩ less than straight leads due to  $l \approx 2\text{ mm}$

<sup>20)</sup> Low ohmic short to  $V_{bb}$  may reduce the output current  $I_L$  and can thus be detected via the sense current  $I_{IS}$ .

<sup>21)</sup> Power Transistor "OFF", potential defined by external impedance.

### Input circuit (ESD protection)

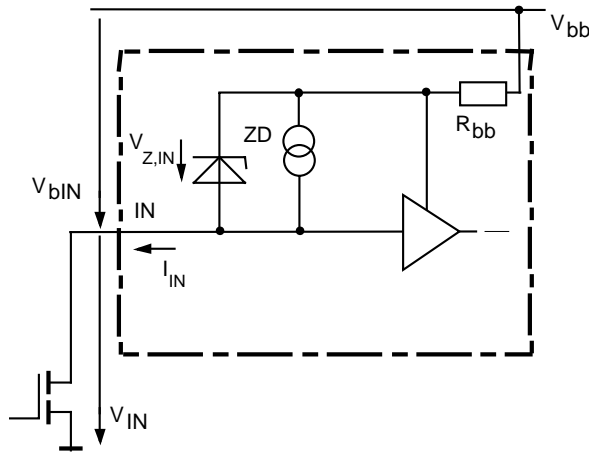

When the device is switched off ( $I_{IN} = 0$ ) the voltage between IN and GND reaches almost  $V_{bb}$ . Use a mechanical switch, a bipolar or MOS transistor with appropriate breakdown voltage as driver.

$V_{Z,IN} = 74\text{ V (typ.)}$ .

### Short circuit detection

Fault Condition:  $V_{ON} > V_{ON(SC)}$  (6 V typ.) and  $t > t_{d(SC)}$  (80 ... 300  $\mu\text{s}$ ).

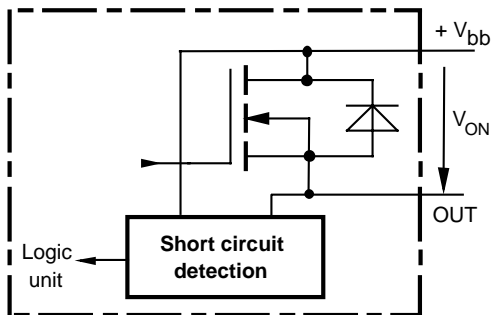

### Current sense status output

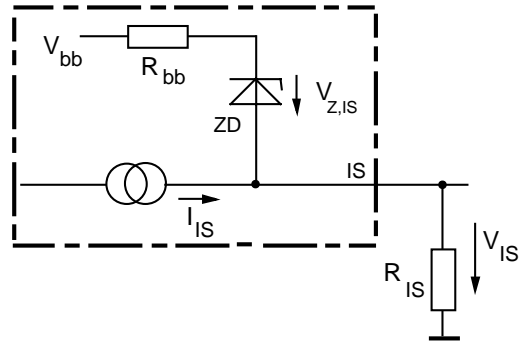

$V_{Z,IS} = 74\text{ V (typ.)}$ ,  $R_{IS} = 1\text{ k}\Omega$  nominal (or  $1\text{ k}\Omega / n$ , if  $n$  devices are connected in parallel).  $I_S = I_L / K_{iis}$  can be driven only by the internal circuit as long as  $V_{out} - V_{IS} > 5\text{ V}$ . If you want measure load currents up to  $I_{L(M)}$ ,  $R_{IS}$  should be less than  $\frac{V_{bb} - 5\text{ V}}{I_{L(M)} / K_{iis}}$ .

Note: For large values of  $R_{IS}$  the voltage  $V_{IS}$  can reach almost  $V_{bb}$ . See also overvoltage protection. If you don't use the current sense output in your application, you can leave it open.

### Inductive and overvoltage output clamp

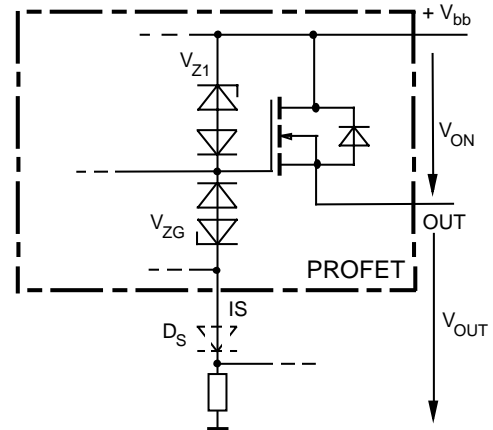

$V_{ON}$  is clamped to  $V_{ON(CL)} = 62\text{ V typ.}$  At inductive load switch-off without  $D_S$ ,  $V_{OUT}$  is clamped to  $V_{OUT(CL)} = -15\text{ V typ.}$  via  $V_{ZG}$ . With  $D_S$ ,  $V_{OUT}$  is clamped to  $V_{bb} - V_{ON(CL)}$  via  $V_{Z1}$ . Using  $D_S$  gives faster deenergizing of the inductive load, but higher peak power dissipation in the PROFET.



### Overvoltage protection of logic part

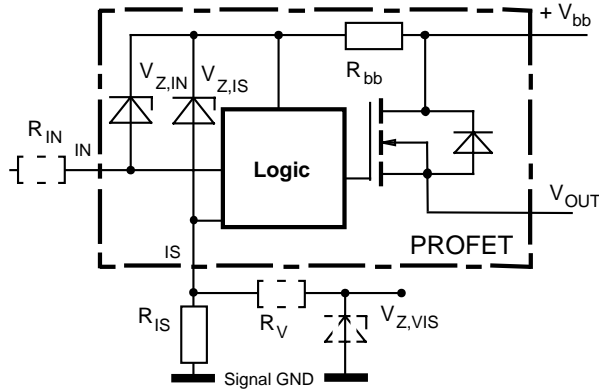

$R_{bb} = 120\Omega$  typ.,  $V_{Z,IN} = V_{Z,IS} = 74V$  typ.,  $R_{IS} = 1k\Omega$  nominal. Note that when overvoltage exceeds  $79V$  typ. a voltage above  $5V$  can occur between  $IS$  and  $GND$ , if  $R_V$ ,  $V_{Z,VIS}$  are not used.

### Reverse battery protection

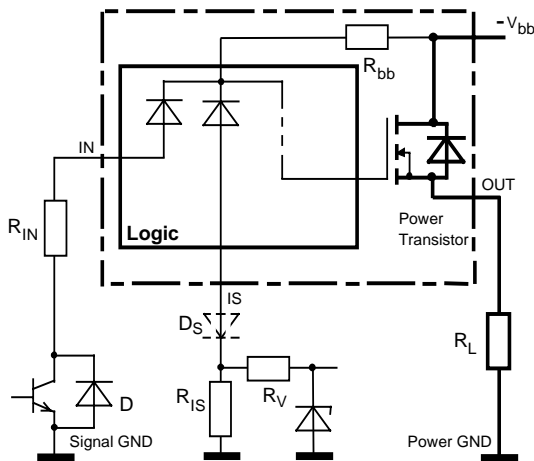

$R_V \geq 1k\Omega$ ,  $R_{IS} = 1k\Omega$  nominal. Add  $R_{IN}$  for reverse battery protection in applications with  $V_{bb}$  above  $16V^{(6)}$ ; recommended value:  $\frac{1}{R_{IN}} + \frac{1}{R_{IS}} + \frac{1}{R_V} = \frac{0.1A}{|V_{bb}| - 12V}$  if  $D_S$  is not used (or  $\frac{1}{R_{IN}} = \frac{0.1A}{|V_{bb}| - 12V}$  if  $D_S$  is used).

To minimize power dissipation at reverse battery operation, the summarized current into the  $IN$  and  $IS$  pin should be about  $120mA$ . The current can be provided by using a small signal diode  $D$  in parallel to the input switch, by using a MOSFET input switch or by proper adjusting the current through  $R_{IS}$  and  $R_V$ .

### $V_{bb}$ disconnect with energized inductive load

Provide a current path with load current capability by using a diode, a Z-diode, or a varistor. ( $V_{ZL} < 70V$  or  $V_{Zb} < 42V$  if  $R_{IN}=0$ ). For higher clamp voltages currents at  $IN$  and  $IS$  have to be limited to  $250mA$ .

Version a:

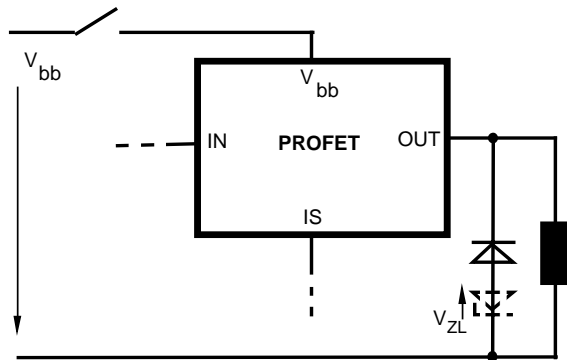

Version b:

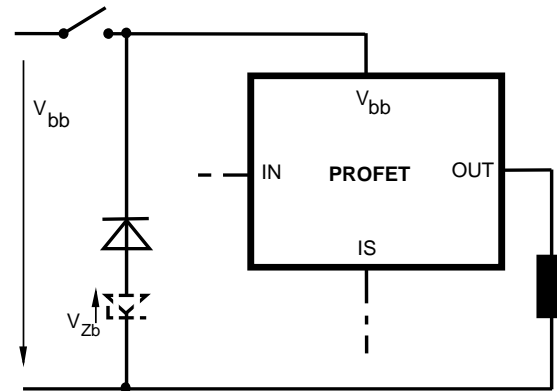

Note that there is no reverse battery protection when using a diode without additional Z-diode  $V_{ZL}$ ,  $V_{Zb}$ .

Version c: Sometimes a necessary voltage clamp is given by non inductive loads  $R_L$  connected to the same switch and eliminates the need of clamping circuit:

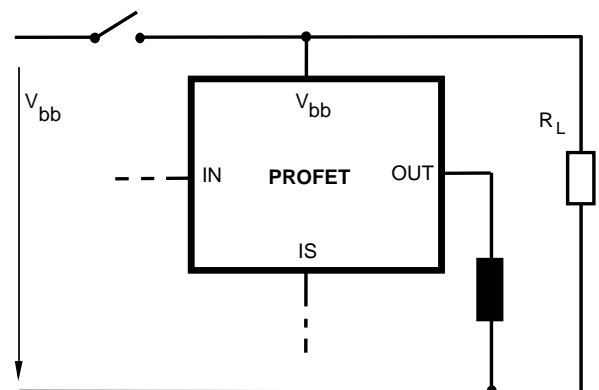

### Inverse load current operation

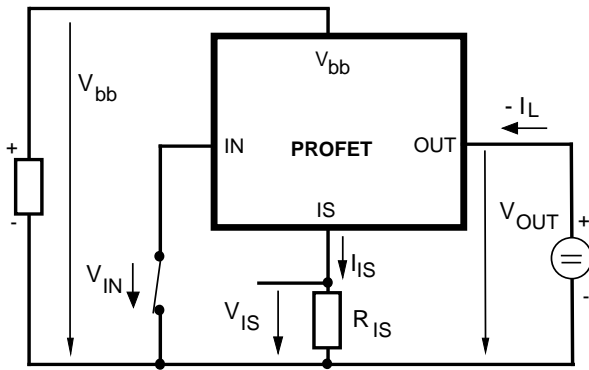

The device is specified for inverse load current operation ( $V_{OUT} > V_{bb} > 0V$ ). The current sense feature is not available during this kind of operation ( $I_{IS} = 0$ ). With  $I_{IN} = 0$  (e.g. input open) only the intrinsic drain source diode is conducting resulting in considerably increased power dissipation. If the device is switched on ( $V_{IN} = 0$ ), this power dissipation is decreased to the much lower value  $R_{ON(INV)} \cdot I^2$  (specifications see page 4).

Note: Temperature protection during inverse load current operation is not possible!

### Inductive load switch-off energy dissipation

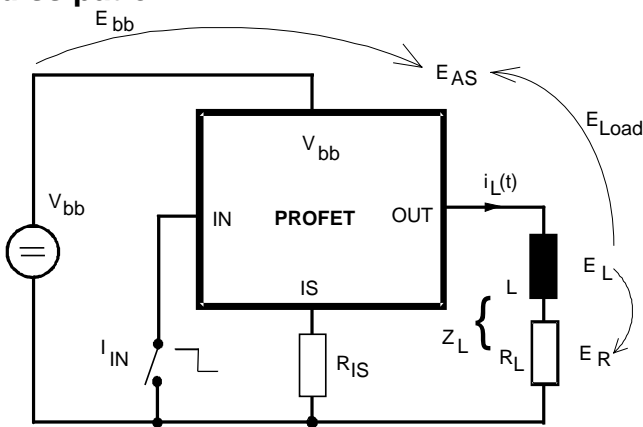

Energy stored in load inductance:

$$E_L = \frac{1}{2} \cdot L \cdot I_L^2$$

While demagnetizing load inductance, the energy dissipated in PROFET is

$$E_{AS} = E_{bb} + E_L - E_R = \int V_{ON(CL)} \cdot i_L(t) dt,$$

with an approximate solution for  $R_L > 0 \Omega$ :

$$E_{AS} = \frac{I_L \cdot L}{2 \cdot R_L} (V_{bb} + |V_{OUT(CL)}|) \ln \left( 1 + \frac{I_L \cdot R_L}{|V_{OUT(CL)}|} \right)$$

### Maximum allowable load inductance for a single switch off

$L = f(I_L)$ ;  $T_{j,start} = 150^\circ C$ ,  $V_{bb} = 12V$ ,  $R_L = 0 \Omega$

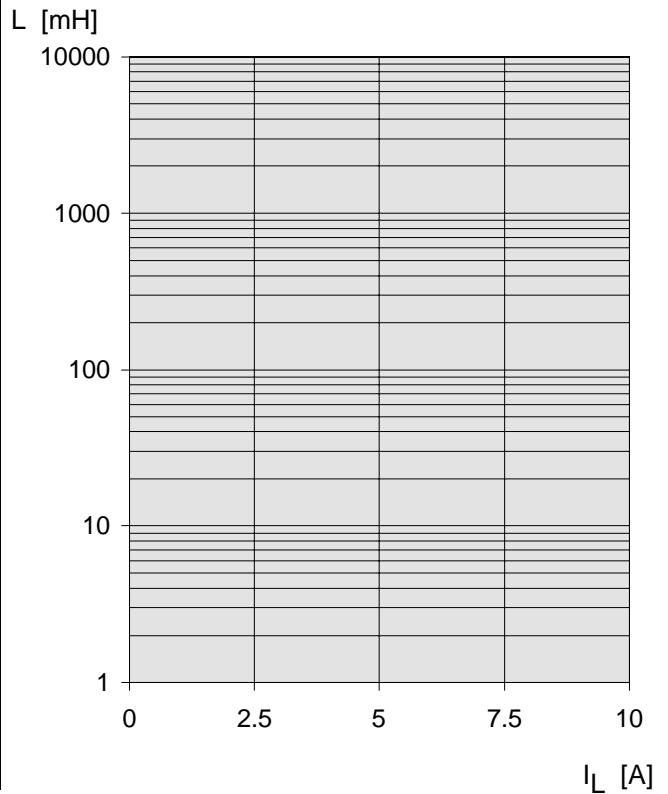

### Options Overview

Type	BTS	660P	560
Overtemperature protection with hysteresis $T_j > 150\text{ °C}$ , latch function <sup>22)</sup>		X	X
$T_j > 150\text{ °C}$ , with auto-restart on cooling		X	
Short circuit to GND protection switches off when $V_{ON} > 6\text{ V}$ typ. (when first turned on after approx. $180\text{ }\mu\text{s}$ )		X	X
Overvoltage shutdown		-	-
Output negative voltage transient limit to $V_{bb} - V_{ON(CL)}$ to $V_{OUT} = -15\text{ V}$ typ		X X <sup>23)</sup>	X X <sup>23)</sup>

<sup>22)</sup> Latch except when  $V_{bb} - V_{OUT} < V_{ON(SC)}$  after shutdown. In most cases  $V_{OUT} = 0\text{ V}$  after shutdown ( $V_{OUT} \neq 0\text{ V}$  only if forced externally). So the device remains latched unless  $V_{bb} < V_{ON(SC)}$  (see page 5). No latch between turn on and  $t_{d(SC)}$ .

<sup>23)</sup> Can be "switched off" by using a diode  $D_S$  (see page 8) or leaving open the current sense output.

### Characteristics

#### Current sense versus load current:

$$I_{IS} = f(I_L), T_J = -40 \dots +150 \text{ } ^\circ\text{C}$$

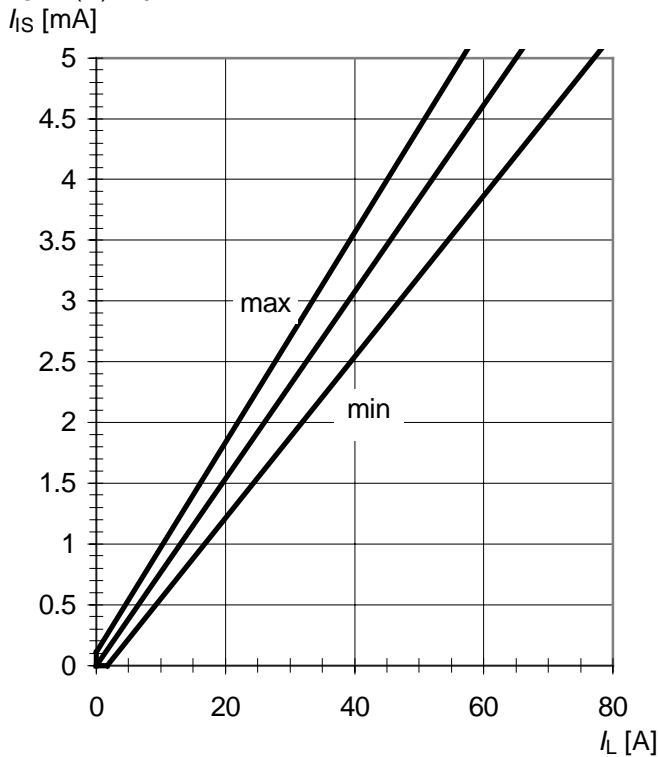

#### Current sense ratio:

$$K_{ILIS} = f(I_L)$$

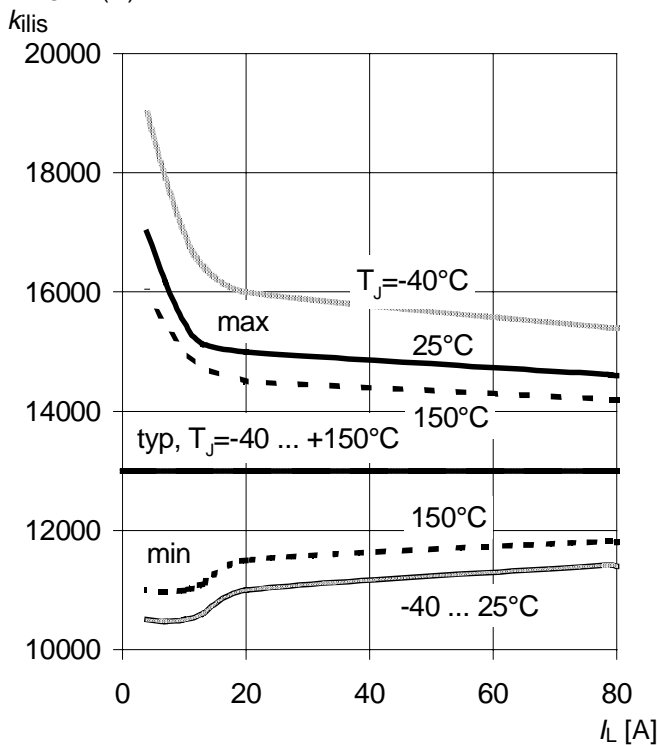

#### Typ. current limitation characteristic

$$I_L = f(V_{ON}, T_J)$$

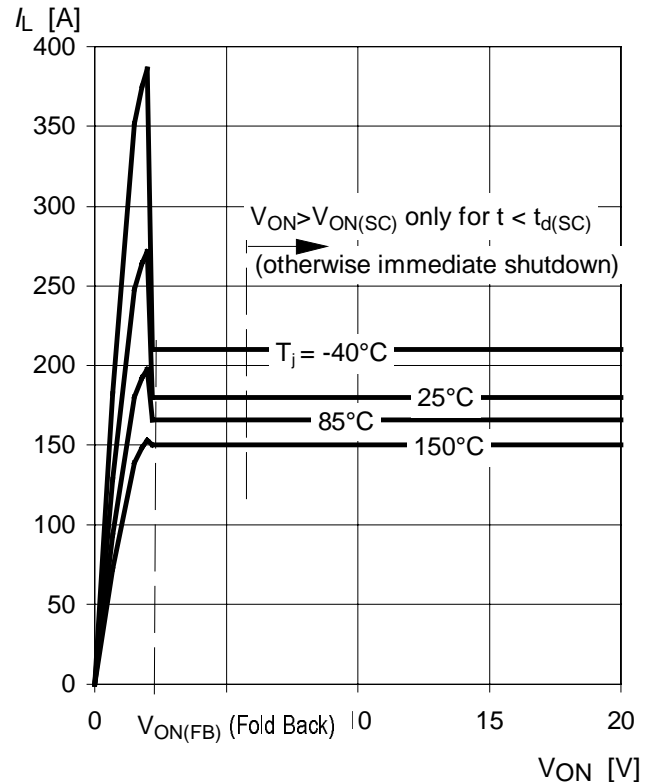

In case of  $V_{ON} > V_{ON(SC)}$  (typ. 6 V) the device will be switched off by internal short circuit detection.

#### Typ. on-state resistance

$$R_{ON} = f(V_{bb}, T_J); I_L = 20 \text{ A}; V_{IN} = 0$$

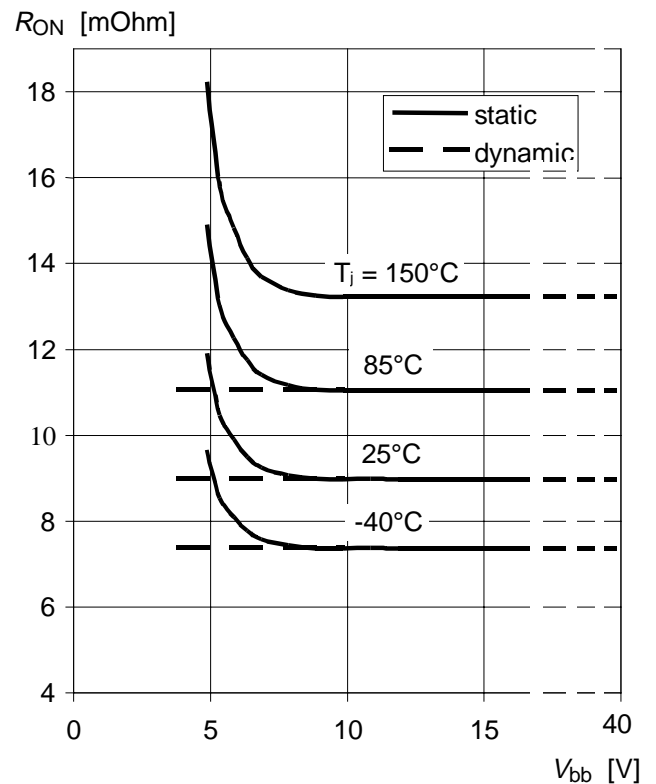

Typ. input current

$$I_{IN} = f(V_{bIN}), V_{bIN} = V_{bb} - V_{IN}$$

$I_{IN}$  [mA]

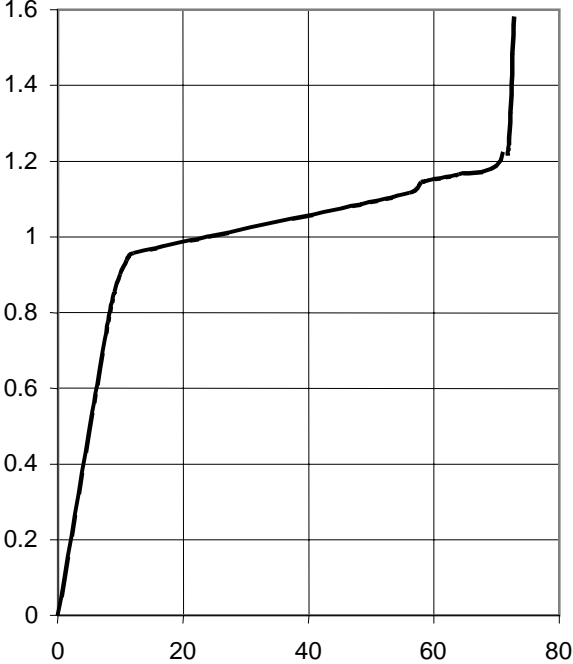

$V_{bIN}$  [V]

### Timing diagrams

**Figure 1a:** Switching a resistive load, change of load current in on-condition:

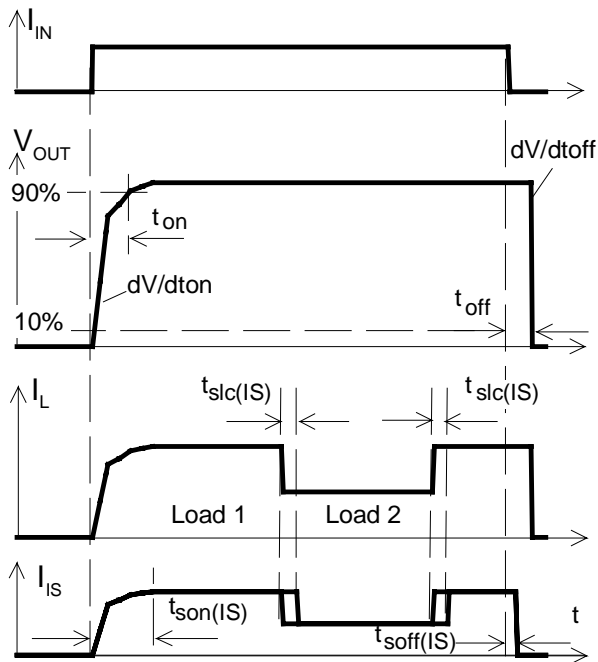

The sense signal is not valid during a settling time after turn-on/off and after change of load current.

**Figure 2a:** Switching motors and lamps:

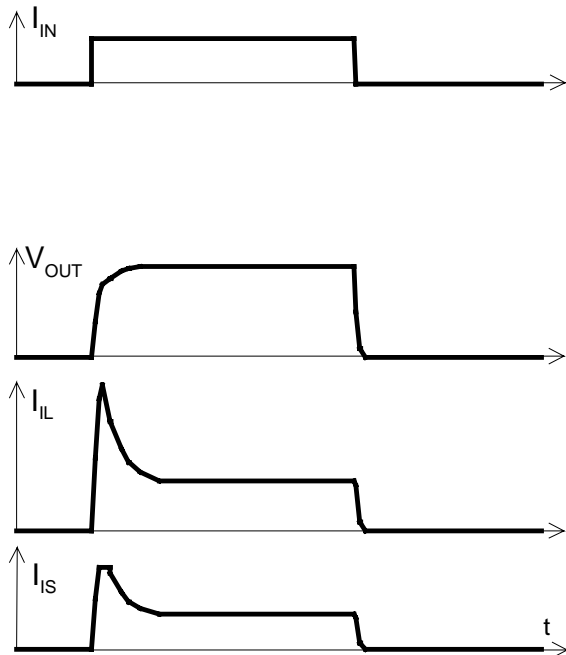

Sense current saturation can occur at very high inrush currents (see  $I_{IS,lim}$  on page 6).

**Figure 2b:** Switching an inductive load:

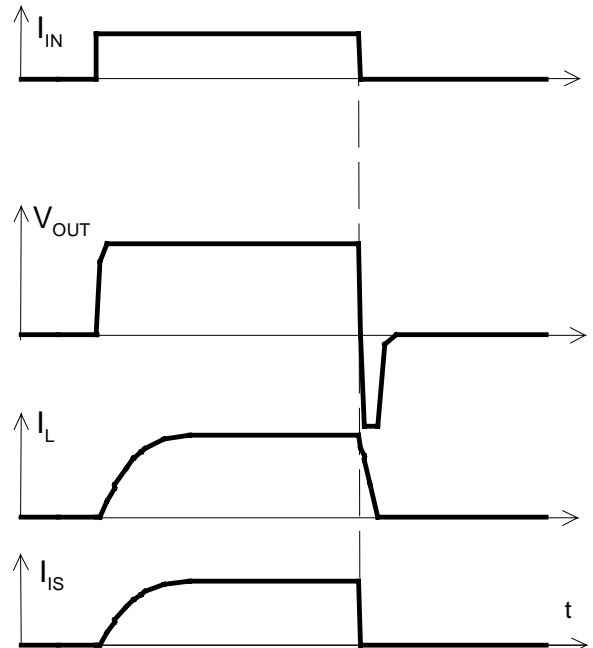

**Figure 3a:** Short circuit:

shut down by short circuit detection, reset by  $I_{IN} = 0$ .

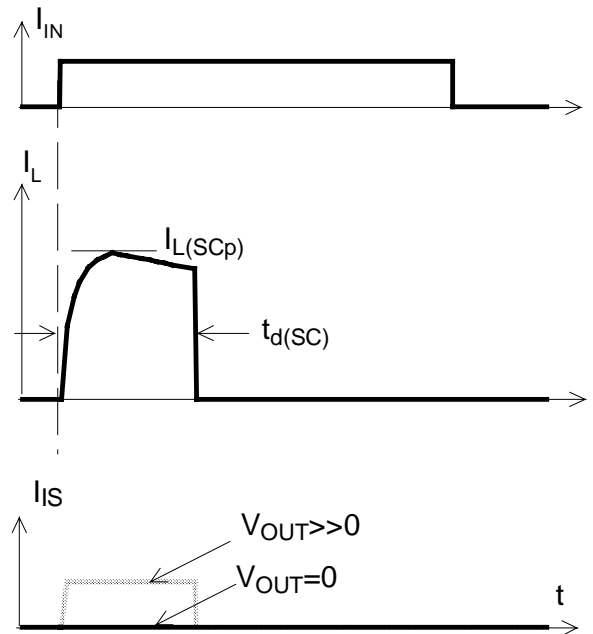

Shut down remains latched until next reset via input.

**Figure 4a:** Overtemperature  
Reset if  $T_j < T_{jt}$

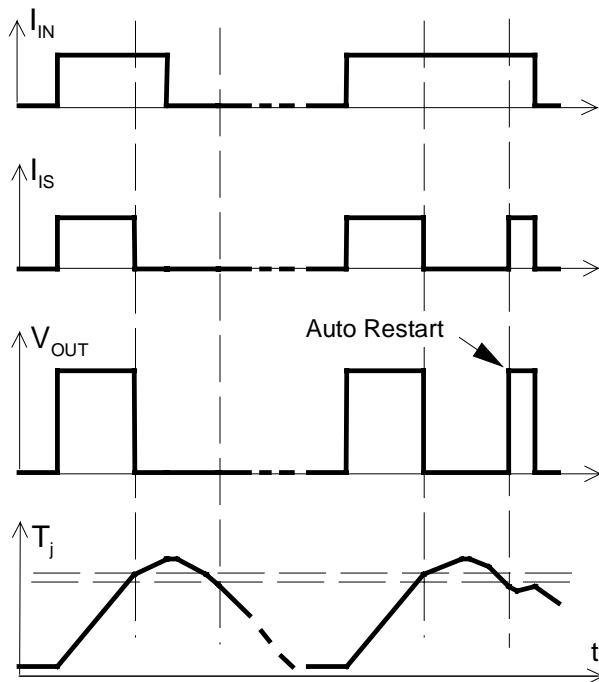

**Figure 6a:** Undervoltage restart of charge pump, overvoltage clamp

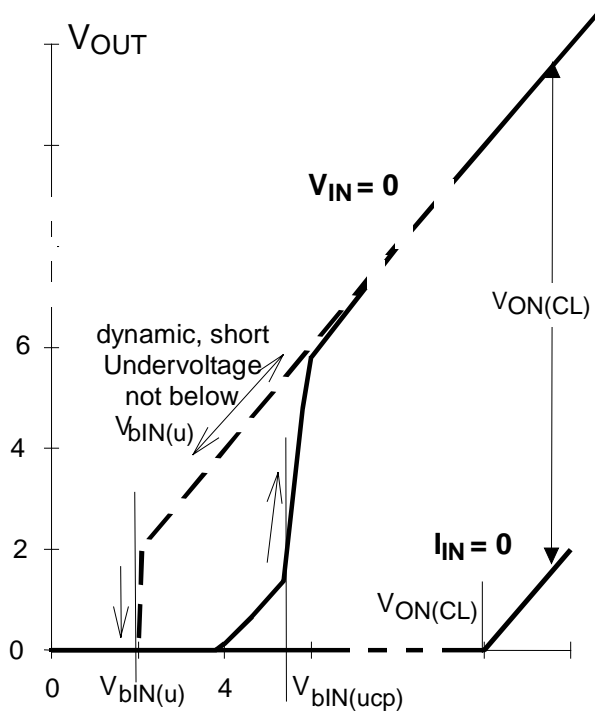

### Package and Ordering Code

All dimensions in mm

**Standard TO-220AB/7**      Ordering code

BTS660P	Q67060-S6308-A2
---------	-----------------

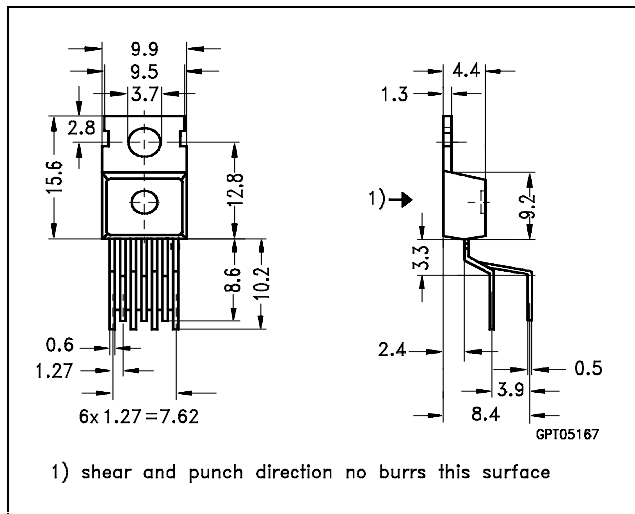

Published by Siemens AG, Bereich Halbleiter Vertrieb, Werbung, Balanstraße 73, D-81541 München

© Siemens AG 1998. All Rights Reserved

**Attention please!**

As far as patents or other rights of third parties are concerned, liability is only assumed for components, not for applications, processes and circuits implemented within components or assemblies. The information describes a type of component and shall not be considered as warranted characteristics. Terms of delivery and rights to change design reserved. For questions on technology, delivery and prices please contact the Semiconductor Group Offices in Germany or the Siemens Companies and Representatives worldwide (see address list). Due to technical requirements components may contain dangerous substances. For information on the types in question please contact your nearest Siemens Office, Semiconductor Group. Siemens AG is an approved CECC manufacturer.

**Packing:** Please use the recycling operators known to you. We can also help you - get in touch with your nearest sales office. By agreement we will take packing material back, if it is sorted. You must bear the costs of transport. For packing material that is returned to us unsorted or which we are not obliged to accept, we shall have to invoice you for any costs incurred.

**Components used in life-support devices or systems must be expressly authorised for such purpose!** Critical components<sup>24)</sup> of the Semiconductor Group of Siemens AG, may only be used in life supporting devices or systems<sup>25)</sup> with the express written approval of the Semiconductor Group of Siemens AG.

**SMD TO 220AB/7, Opt. E3180** Ordering code

BTS660P E3180A	T&R: Q67060-S6308-A4
----------------	----------------------

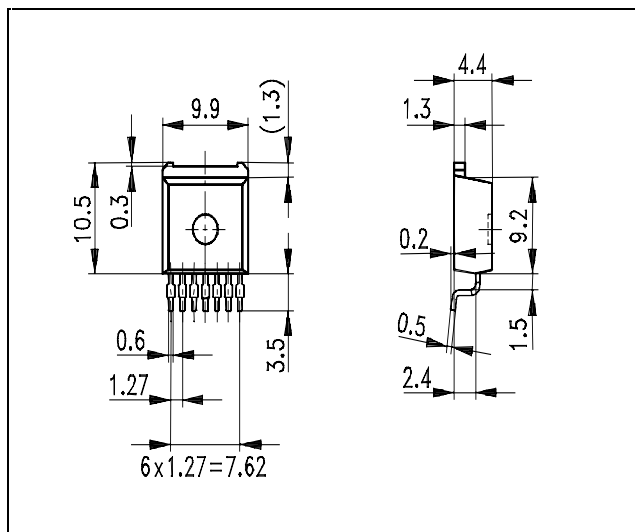

Footprint:

<b>on request</b>
-------------------

<sup>24)</sup> A critical component is a component used in a life-support device or system whose failure can reasonably be expected to cause the failure of that life-support device or system, or to affect its safety or effectiveness of that device or system.

<sup>25)</sup> Life support devices or systems are intended (a) to be implanted in the human body or (b) support and/or maintain and sustain and/or protect human life. If they fail, it is reasonable to assume that the health of the user or other persons may be endangered.