

DATA SHEET

TDA5630; TDA5631

9 V VHF, hyperband and UHF
mixer/oscillator for TV and VCR
3-band tuners

Product specification
File under Integrated Circuits, IC02

1996 Mar 21

9 V VHF, hyperband and UHF mixer/oscillator for TV and VCR 3-band tuners

**TDA5630;
TDA5631**

FEATURES

- Balanced mixer with a common emitter input for band A (single input)
- 2-pin oscillator for bands A and B
- Balanced mixer with a common base input for bands B and C (balanced input)
- 3-pin oscillator for band C
- Local oscillator buffer output for external synthesizer
- SAW filter preamplifier with a low output impedance to drive the SAW filter directly
- Band gap voltage stabilizer for oscillator stability
- Electronic band switch.

APPLICATIONS

- 3-band all channel TV and VCR tuners
- Any standard.

QUICK REFERENCE DATA

SYMBOL	PARAMETER	CONDITIONS	MIN.	TYP.	MAX.	UNIT
V_P	supply voltage		–	9.0	–	V
I_P	supply current		–	35	–	mA
f_{RF}	frequency range	RF input; band A; note 1	45	–	180	MHz
		RF input; band B; note 1	160	–	470	MHz
		RF input; band C; note 1	430	–	860	MHz
G_V	voltage gain	band A	–	25	–	dB
		band B	–	36	–	dB
		band C	–	36	–	dB
NF	noise figure	band A	–	7.5	–	dB
		band B	–	8	–	dB
		band C	–	9	–	dB
V_o	output voltage to get 1% cross modulation in channel	band A	–	118	–	dB μ V
		band B	–	118	–	dB μ V
		band C	–	118	–	dB μ V

Note

1. The limits are related to the tank circuits used in Fig.12 and the intermediate frequency. Frequency bands may be adjusted by the choice of external components.

GENERAL DESCRIPTION

The TDA5630 and TDA5631 are monolithic integrated circuits that perform the mixer/oscillator functions for bands A, B and C in TV and VCR tuners. These low-power mixer/oscillators require a power supply of 9 V and are available in a very small package.

The devices give the designer the capability to design an economical and physically small 3-band tuner.

They are suitable for European standards, as illustrated in Fig.12, with the following RF bands: 48.25 to 168.25 MHz, 175.25 to 447.25 MHz and 455.25 to 855.25 MHz. With an appropriate tuned circuit, they are also suitable for NTSC all channel tuners (USA and Japan).

The tuner development time can be drastically reduced by using these devices.

9 V VHF, hyperband and UHF
 mixer/oscillator for TV and VCR 3-band tuners

TDA5630;
 TDA5631

ORDERING INFORMATION

TYPE NUMBER	PACKAGE		
	NAME	DESCRIPTION	VERSION
TDA5630T	SO20	plastic small outline package; 20 leads; body width 7.5 mm	SOT163-1
TDA5630M	SSOP20	plastic shrink small outline package; 20 leads; body width 4.4 mm	SOT266-1
TDA5631T	SO20	plastic small outline package; 20 leads; body width 7.5 mm	SOT163-1
TDA5631M	SSOP20	plastic shrink small outline package; 20 leads; body width 4.4 mm	SOT266-1

BLOCK DIAGRAM

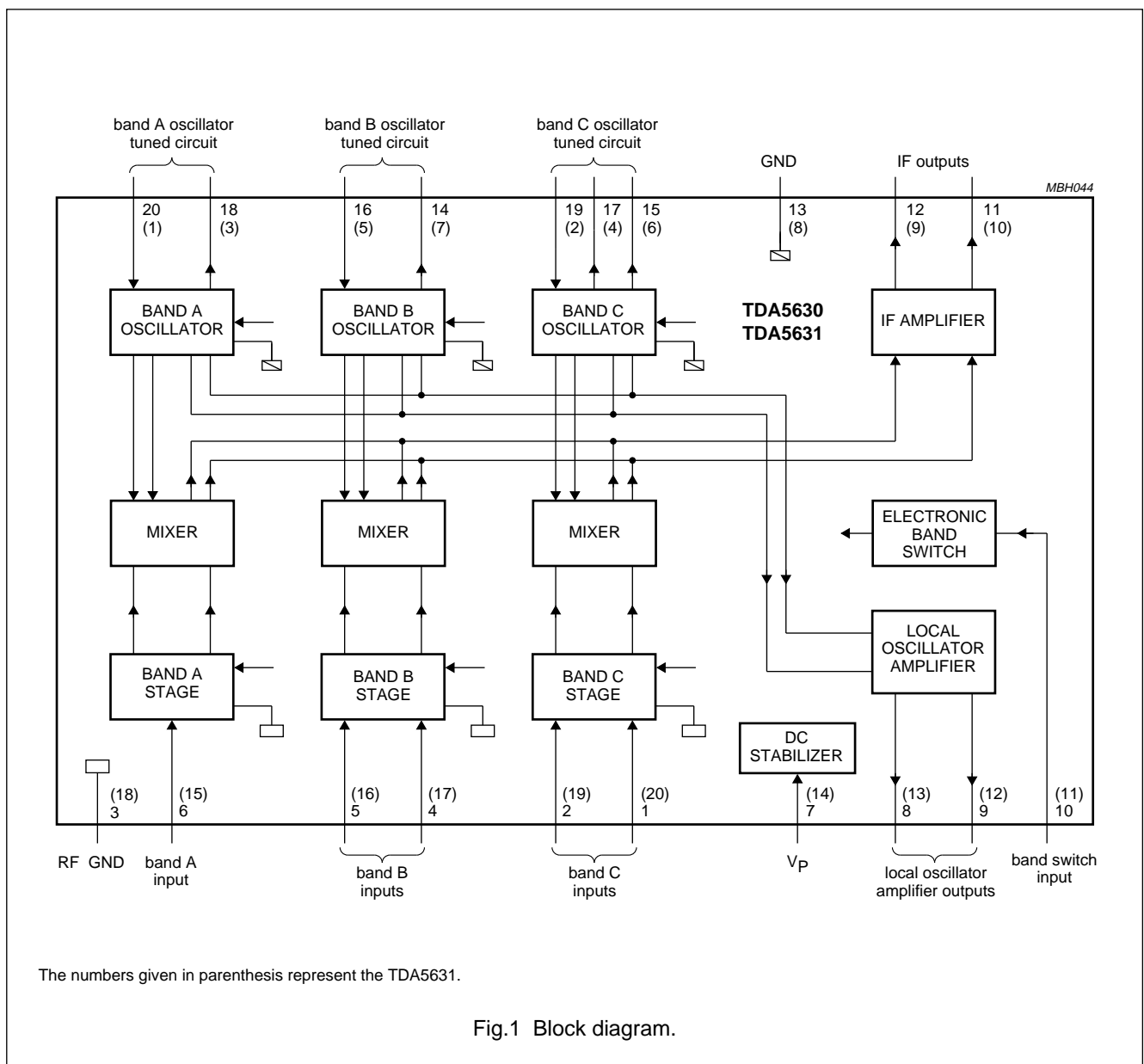

Fig.1 Block diagram.

9 V VHF, hyperband and UHF
 mixer/oscillator for TV and VCR 3-band tuners

TDA5630;
 TDA5631

PINNING

SYMBOL	PIN		DESCRIPTION
	TDA5630	TDA5631	
CIN1	1	20	band C input 1
CIN2	2	19	band C input 2
RFGND	3	18	ground for RF inputs
BIN1	4	17	band B input 1
BIN2	5	16	band B input 2
AIN	6	15	band A input
V _P	7	14	supply voltage
LOOUT1	8	13	local oscillator amplifier output 1
LOOUT2	9	12	local oscillator amplifier output 2
BS	10	11	band switch input
IFOUT1	11	10	IF amplifier output 1
IFOUT2	12	9	IF amplifier output 2
GND	13	8	ground (0 V)
BOSCOC	14	7	band B oscillator output collector
COSCOC1	15	6	band C oscillator output collector 1
BOSCIB	16	5	band B oscillator input base
COSCOC2	17	4	band C oscillator output collector 2
AOSCOC	18	3	band A oscillator output collector
COSCIB	19	2	band C oscillator input base
AOSCIB	20	1	band A oscillator input base

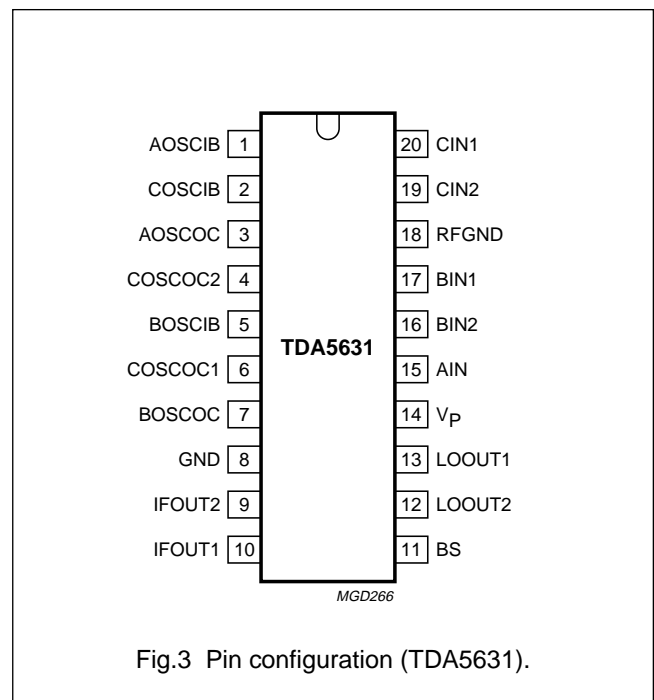
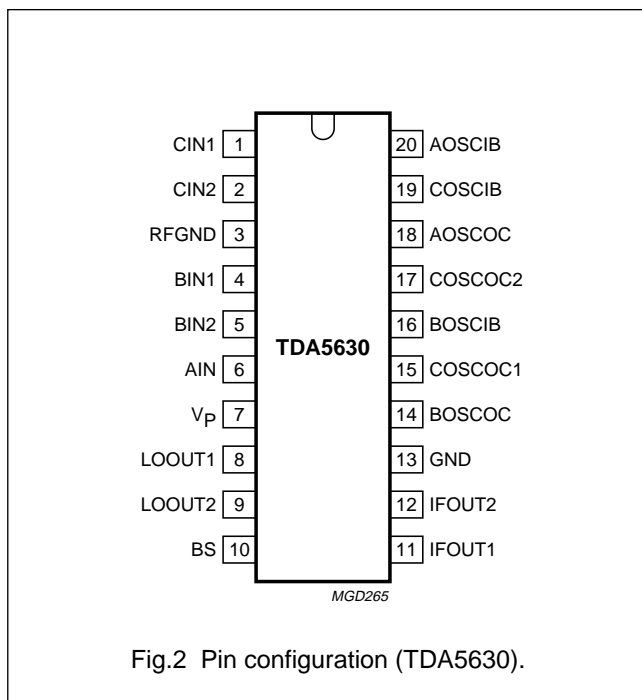

9 V VHF, hyperband and UHF
mixer/oscillator for TV and VCR 3-band tuners

TDA5630;
TDA5631

LIMITING VALUES

In accordance with the Absolute Maximum Rating System (IEC 134).

SYMBOL	PARAMETER	MIN.	MAX.	UNIT
V_P	supply voltage	-0.3	+10.5	V
V_{SW}	switching voltage	0	10.5	V
I_O	output current of each pin referenced to ground	-	-10	mA
t_{sc}	maximum short-circuit time (all pins)	-	10	s
T_{stg}	IC storage temperature	-55	+150	°C
T_{amb}	operating ambient temperature	-10	+80	°C
T_j	junction temperature	-	+150	°C

THERMAL CHARACTERISTICS

SYMBOL	PARAMETER	VALUE	UNIT
$R_{th\ j-a}$	thermal resistance from junction to ambient in free air		
	SOT163-1	100	K/W
	SOT266-1	120	K/W

HANDLING

Human body model: the IC withstands 2000 V in accordance with the MIL-STD-883C category B (stress reference pins 3, 7 and 13 shorted together for the TDA5630; pins 18, 14 and 8 for the TDA5631).

Machine model: the IC withstands 200 V in accordance with the MIL-STD-883C (stress reference pins 3, 7 and 13 shorted together for the TDA5630; pins 18, 14 and 8 for the TDA5631).

9 V VHF, hyperband and UHF mixer/oscillator for TV and VCR 3-band tuners

TDA5630; TDA5631

CHARACTERISTICS

$V_P = 9\text{ V}$; $T_{\text{amb}} = 25\text{ °C}$; measured in circuit of Fig.12; unless otherwise specified.

SYMBOL	PARAMETER	CONDITIONS	MIN.	TYP.	MAX.	UNIT
Supply						
V_P	supply voltage		8.1	9.0	9.9	V
I_P	supply current		–	35	45	mA
V_{SW}	switching voltage	band A	0	–	1.1	V
		band B	1.6	–	2.4	V
		band C	3.0	–	5.0	V
I_{SW}	switching current	band A	–	–	2	μA
		band B	–	–	5	μA
		band C	–	–	10	μA
Band A mixer including IF amplifier						
f_{RF}	frequency range	note 1	45	–	180	MHz
G_v	voltage gain	$f_{\text{RF}} = 50\text{ MHz}$; see Fig.4; note 2	22.5	25	27.5	dB
		$f_{\text{RF}} = 180\text{ MHz}$; see Fig.4; note 2	22.5	25	27.5	dB
NF	noise figure	$f_{\text{RF}} = 50\text{ MHz}$; see Figs 5 and 6	–	7.5	9	dB
		$f_{\text{RF}} = 180\text{ MHz}$; see Figs 5 and 6	–	9	10	dB
V_o	output voltage causing 1% cross modulation in channel	$f_{\text{RF}} = 180\text{ MHz}$; see Fig.7	115	118	–	$\text{dB}\mu\text{V}$
V_i	input voltage causing 10 kHz pulling in channel	$f_{\text{RF}} = 180\text{ MHz}$; note 3	–	100	–	$\text{dB}\mu\text{V}$
g_{os}	optimum source conductance for noise figure	$f_{\text{RF}} = 50\text{ MHz}$	–	0.5	–	mS
		$f_{\text{RF}} = 180\text{ MHz}$	–	1.1	–	mS
g_i	input conductance	$f_{\text{RF}} = 50\text{ MHz}$; see Fig.13; note 4	–	0.26	–	mS
		$f_{\text{RF}} = 180\text{ MHz}$; see Fig.13; note 4	–	0.35	–	mS
C_i	input capacitance	$f_{\text{RF}} = 50\text{ to }180\text{ MHz}$; see Fig.13; note 4	–	2	–	pF
Band A oscillator						
f_{osc}	frequency range	note 5	80	–	216	MHz
f_{shift}	frequency shift	$\Delta V_P = 10\%$; note 6	–	–	200	kHz
f_{drift}	frequency drift	$\Delta T = 25\text{ °C}$ with no compensation; NPO capacitors; note 7	–	–	500	kHz
		5 s to 15 min after switch on; with no compensation; NPO capacitors; note 8	–	–	200	kHz

9 V VHF, hyperband and UHF
mixer/oscillator for TV and VCR 3-band tuners

TDA5630;
TDA5631

SYMBOL	PARAMETER	CONDITIONS	MIN.	TYP.	MAX.	UNIT
Band B mixer including IF amplifier; measurements using hybrid; note 9						
f_{RF}	frequency range	note 1	160	–	470	MHz
G_v	voltage gain	$f_{RF} = 170$ MHz; see Fig.8; note 2	33	36	39	dB
		$f_{RF} = 470$ MHz; see Fig.8; note 2	33	36	39	dB
NF	noise figure (not corrected for image)	$f_{RF} = 170$ MHz; see Fig.9	–	8	10	dB
		$f_{RF} = 470$ MHz; see Fig.9	–	8	10	dB
V_o	output voltage causing 1% cross modulation in channel	$f_{RF} = 170$ MHz; see Fig.10	115	118	–	dB μ V
		$f_{RF} = 470$ MHz; see Fig.10	115	118	–	dB μ V
V_i	input voltage causing 10 kHz pulling in channel	$f_{RF} = 470$ MHz; TDA5630T and TDA5631T; note 3	–	91	–	dB μ V
		$f_{RF} = 470$ MHz; TDA5630M and TDA5631M; note 3	–	83	–	dB μ V
	input voltage causing N + 5 – 1 MHz pulling	$f_{RF} = 430$ MHz; TDA5630T and TDA5631T; see Fig.11	–	81	–	dB μ V
		$f_{RF} = 430$ MHz; TDA5630M and TDA5631M; see Fig.11	–	66	–	dB μ V
Z_i	input impedance ($R_S + jL_S\omega$)	R_S ; see Fig.14; note 4	–	30	–	Ω
		L_S ; see Fig.14; note 4	–	8	–	nH
Band B oscillator						
f_{OSC}	frequency range	note 5	200	–	500	MHz
f_{shift}	frequency shift	$\Delta V_P = 10\%$; note 6	–	–	400	kHz
f_{drift}	frequency drift	$\Delta T = 25$ °C with no compensation: NP0 capacitors; note 7	–	–	2	MHz
		5 s to 15 min after switch on; with no compensation: NP0 capacitors; note 8	–	–	300	kHz
Band C mixer including IF amplifier; measurements using hybrid; note 9						
f_{RF}	frequency range	note 1	430	–	860	MHz
G_v	voltage gain	$f_{RF} = 430$ MHz; see Fig.8; note 2	33	36	39	dB
		$f_{RF} = 860$ MHz; see Fig.8; note 2	33	36	39	dB
NF	noise figure (not corrected for image)	$f_{RF} = 430$ MHz; see Fig.9	–	9	11	dB
		$f_{RF} = 860$ MHz; see Fig.9	–	9	11	dB
V_o	output voltage causing 1% cross modulation in channel	$f_{RF} = 430$ MHz; see Fig.10	115	118	–	dB μ V
		$f_{RF} = 860$ MHz; see Fig.10	115	118	–	dB μ V
V_i	input voltage causing 10 kHz pulling in channel	$f_{RF} = 860$ MHz; TDA5630T and TDA5631T; note 3	–	87	–	dB μ V
		$f_{RF} = 860$ MHz; TDA5630M and TDA5631M; note 3	–	93	–	dB μ V
	input voltage causing N + 5 – 1 MHz pulling	$f_{RF} = 820$ MHz; see Fig.11	–	61	–	dB μ V

9 V VHF, hyperband and UHF
mixer/oscillator for TV and VCR 3-band tuners

TDA5630;
TDA5631

SYMBOL	PARAMETER	CONDITIONS	MIN.	TYP.	MAX.	UNIT
Z_i	input impedance ($R_S + jL_S\omega$)	R_S at $f_{RF} = 430$ MHz; see Fig.15; note 4	–	40	–	Ω
		R_S at $f_{RF} = 860$ MHz; see Fig.15; note 4	–	53	–	Ω
		L_S at $f_{RF} = 430$ to 860 MHz; see Fig.15; note 4	–	9	–	nH
Band C oscillator						
f_{OSC}	frequency range	note 5	470	–	900	MHz
f_{shift}	frequency shift	$\Delta V_P = 10\%$; note 6	–	–	400	kHz
f_{drift}	frequency drift	$\Delta T = 25$ °C with no compensation; NP0 capacitors; note 7	–	–	2.5	MHz
		5 s to 15 min after switch on; with no compensation; NP0 capacitors; note 8	–	–	600	kHz
IF amplifier						
S_{22}	output reflection coefficient	magnitude; see Fig.16; note 4	–	–10	–	dB
		phase; see Fig.16; note 4	–	9	–	°
Z_o	output impedance ($R_S + jL_S\omega$)	R_S ; see Fig.16; note 4	–	95	–	Ω
		L_S ; see Fig.16; note 4	–	45	–	nH
LO output; $R_L = 100 \Omega$						
Y_o	output admittance ($G_P + jC_P\omega$)	$f_{osc} = 80$ MHz; see Fig.17; note 4	–	2.5	–	mS
			–	0.9	–	pF
		$f_{osc} = 900$ MHz; see Fig.17; note 4	–	3.5	–	mS
			–	0.7	–	pF
V_o	output voltage	$R_L = 100 \Omega$	83	91	100	dB μ V
SRF	spurious signal on LO output with respect to LO output signal	note 10	–	–	–10	dBc
SHD	LO signal harmonics with respect to LO signal		–	–	–10	dBc

**9 V VHF, hyperband and UHF
mixer/oscillator for TV and VCR 3-band tuners**

**TDA5630;
TDA5631****Notes to the characteristics**

1. The RF frequency range is defined by the oscillator frequency range and the intermediate frequency.
2. The gain is defined as the transducer gain (measured in Fig.12) plus the voltage transformation ratio of L6 to L7 (10 : 2, 15.4 dB including transformer loss).
3. The input level causing 10 kHz frequency detuning at the LO output. $f_{osc} = f_{RF} + 33.4$ MHz.
4. All S-parameters are referred to a 50 Ω system.
5. Limits are related to the tank circuits used in Fig.12. Frequency bands may be adjusted by the choice of external components.
6. The frequency shift is defined for a variation of power supply, first from $V_P = 9$ to 8.1 V, then from $V_P = 9$ to 9.9 V. In both cases, the frequency shift is below the specified value.
7. The frequency drift is defined for a variation of ambient temperature, first from $T_{amb} = 25$ °C to $T_{amb} = 0$ °C, then from $T_{amb} = 25$ °C to $T_{amb} = 50$ °C. In both cases, the frequency drift is below the specified value with NPO capacitors. Capacitor types C1 to C11, as specified in Fig.12 for non-PLL applications, must be changed to series with other temperature coefficients (e.g. N330, N750 etc.).
8. Switch on drift is the change of oscillator frequency between 5s and 15 min after switch on.
9. The values have been corrected for hybrid and cable losses. The symmetrical output impedance of the hybrid is 100 Ω .
10. Measured with RF input voltage:
 - a) RF voltage = 120 dB μ V at $f_{RF} < 180$ MHz.
 - b) RF voltage = 107.5 dB μ V at 180 MHz $< f_{RF} < 225$ MHz.
 - c) RF voltage = 97 dB μ V at 225 MHz $< f_{RF} < 860$ MHz.

9 V VHF, hyperband and UHF
 mixer/oscillator for TV and VCR 3-band tuners

TDA5630;
 TDA5631

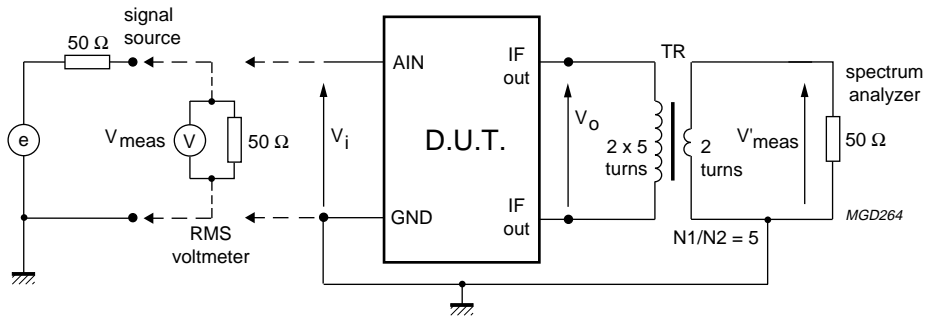

$Z_{in} (AIN) \gg 50 \Omega \Rightarrow V_i = 2 \times V_{meas}$.
 $V_i = V_{meas} + 6 \text{ dB}$.
 $V_o = V'_{meas} + 15.4 \text{ dB}$ (transformer ratio $N1/N2 = 5$ and transformer loss).
 $G_v = 20 \log (V_o/V_i) = 20 \log (V'_{meas}/V_{meas}) + 9.4 \text{ dB}$.

Fig.4 Gain measurement in band A.

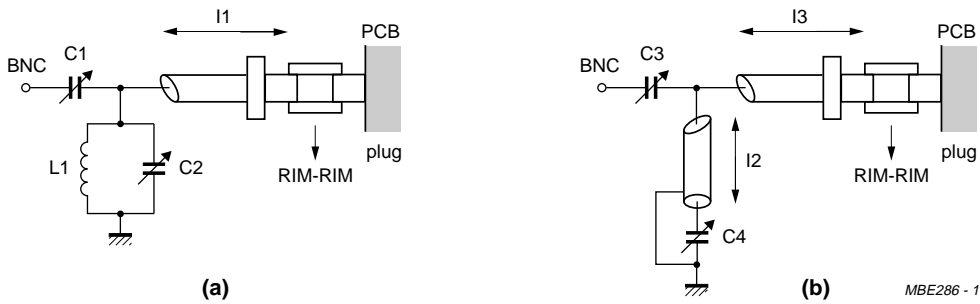

(a) For $f_{RF} = 50 \text{ MHz}$:
 mixer A frequency response measured = 57 MHz, loss = 0 dB
 image suppression = 16 dB
 $C1 = 9 \text{ pF}$
 $C2 = 15 \text{ pF}$
 $L1 = 7 \text{ turns}$ (diam. = 5.5 mm, wire diam. = 0.5 mm)
 $l1 = \text{semi rigid cable (RIM): } 5 \text{ cm long}$
 (semi rigid cable (RIM); 33 dB/100 m; 50 Ω ; 96 pF/m).

(b) For $f_{RF} = 180 \text{ MHz}$:
 mixer A frequency response measured = 150.3 MHz, loss = 1.3 dB
 image suppression = 13 dB
 $C3 = 5 \text{ pF}$
 $C4 = 25 \text{ pF}$
 $l2 = \text{semi rigid cable (RIM): } 30 \text{ cm long}$
 $l3 = \text{semi rigid cable (RIM): } 5 \text{ cm long}$
 (semi rigid cable (RIM); 33 dB/100 m; 50 Ω ; 96 pF/m).

Fig.5 Input circuit for optimum noise figure in band A.

9 V VHF, hyperband and UHF
 mixer/oscillator for TV and VCR 3-band tuners

TDA5630;
 TDA5631

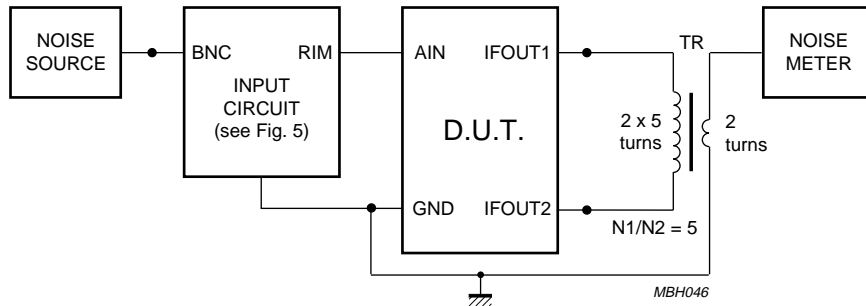

(1) $NF = NF_{meas} - \text{loss (input circuit) dB}$.

Fig.6 Noise figure measurement in band A.

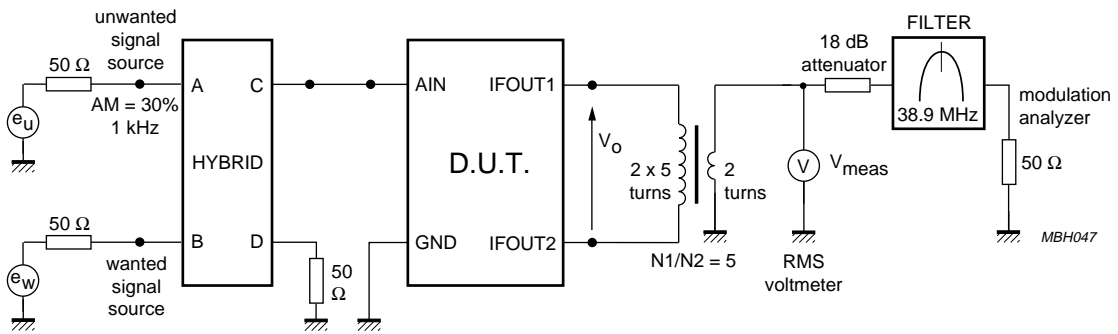

$V_{meas} = V_o - 15.4 \text{ dB}$ (transformer ratio $N1/N2 = 5$ and transformer loss).
 Wanted output signal at $f_{RFW} = 180 \text{ MHz}$: $V_{ow} = 104 \text{ dB}\mu\text{V}$ ($V_{meas} = 88.6 \text{ dB}\mu\text{V}$).
 We measure the level of the unwanted signal V_{ou} causing 0.3 % AM modulation in the wanted output signal; $f_{RFU} = 185.5 \text{ MHz}$.
 $V_{ou} = V_{meas} + 15.4 \text{ dB}$.
 $f_{osc} = 218.9 \text{ MHz}$.
 Filter characteristics: $f_c = 38.9 \text{ MHz}$, $f_{-3\text{dB BW}} = 1.2 \text{ MHz}$, $f_{-30\text{dB BW}} = 2.64 \text{ MHz}$.

Fig.7 Cross modulation measurement in band A.

9 V VHF, hyperband and UHF
 mixer/oscillator for TV and VCR 3-band tuners

TDA5630;
 TDA5631

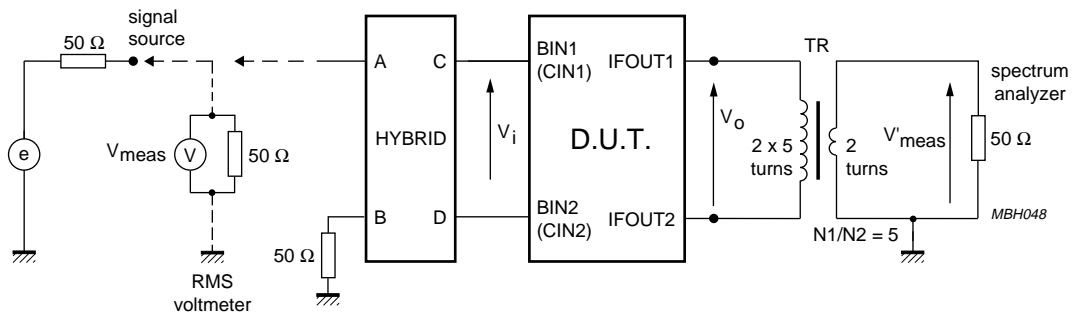

Loss of the hybrid: 0.8 to 1 dB depending on frequency.
 $V_i = V_{meas} - \text{loss of the hybrid.}$
 $V_o = V'_{meas} + 15.4 \text{ dB (transformer ratio } N1/N2 = 5 \text{ and transformer loss.)}$
 $G_v = 20 \log (V_o/V_i) = 20 \log (V'_{meas}/V_{meas}) + 15.4 \text{ dB} + \text{loss of the hybrid.}$

Fig.8 Gain measurement in bands B and C.

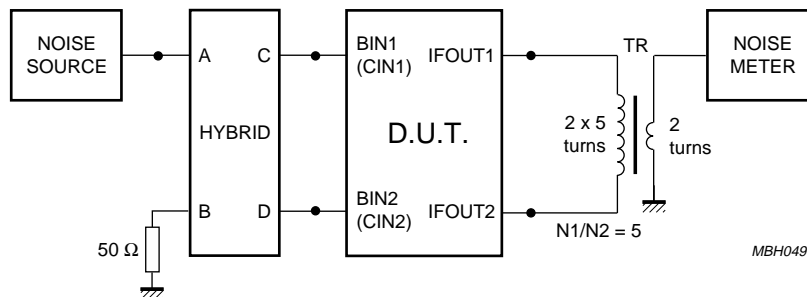

Loss of the hybrid: 0.8 to 1 dB depending on frequency.
 $NF = NF_{meas} - \text{loss of the hybrid.}$

Fig.9 Noise figure measurement in bands B and C.

9 V VHF, hyperband and UHF
 mixer/oscillator for TV and VCR 3-band tuners

TDA5630;
 TDA5631

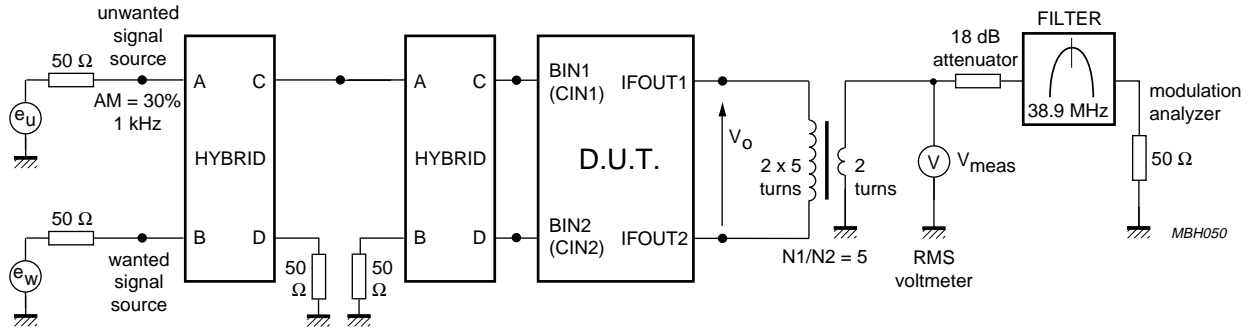

$V_{meas} = V_o - 15.4 \text{ dB}$ (transformer ratio $N1/N2 = 5$ and transformer loss).
 Wanted output signal at f_{RFW} : $V_{ow} = 108 \text{ dB}\mu\text{V}$, $V_{meas} = 92.6 \text{ dB}\mu\text{V}$.
 We measure the level of the unwanted output signal V_{ou} causing 0.3 % AM modulation in the wanted output signal.
 $V_{ou} = V_{meas} + 15.4 \text{ dB}$.
 $f_{RFU} = f_{RFW} + 5.5 \text{ MHz}$; $f_{osc} = f_{RF} + 38.9 \text{ MHz}$.
 Filter characteristics: $f_c = 38.9 \text{ MHz}$; $f_{-3\text{dB BW}} = 1.2 \text{ MHz}$; $f_{-30\text{dB BW}} = 2.64 \text{ MHz}$.

Fig.10 Cross modulation measurement in bands B and C.

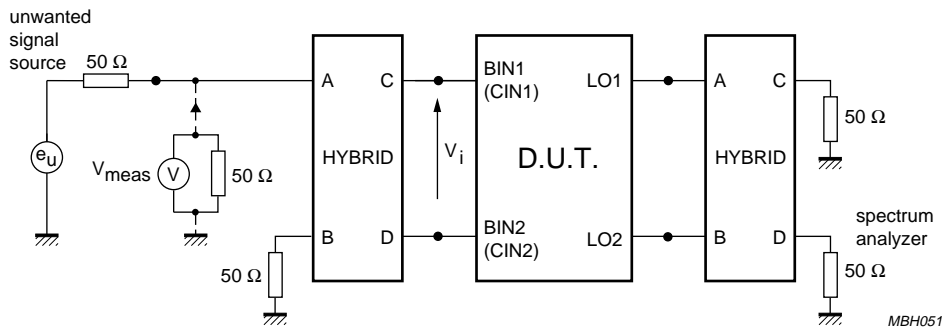

Loss of the hybrid: 0.8 to 1 dB depending on frequency.
 In band B: $f_{RFW} = 391 \text{ MHz}$ (in band C: $f_{RFW} = 781 \text{ MHz}$). These wanted signals are not used during the measurement.
 In band B: $f_{osc} = 429.9 \text{ MHz}$ (in band C: $f_{osc} = 819.9 \text{ MHz}$).
 In band B: $f_{RFU} = 430 \text{ MHz} = f_{RFW} + 5 \times 8 \text{ MHz} - 1 \text{ MHz}$. (in band C: $f_{RFU} = 820 \text{ MHz} = f_{RFW} + 5 \times 8 \text{ MHz} - 1 \text{ MHz}$).
 We measure the level of the unwanted signal V_{iu} causing fm sidebands 30 dB below the oscillator carrier at the LO output.
 $V_{iu} = V_{meas} - \text{loss of the hybrid}$.

Fig.11 N + 5 - 1 MHz pulling measurement in bands B and C.

9 V VHF, hyperband and UHF
 mixer/oscillator for TV and VCR 3-band tuners

TDA5630;
 TDA5631

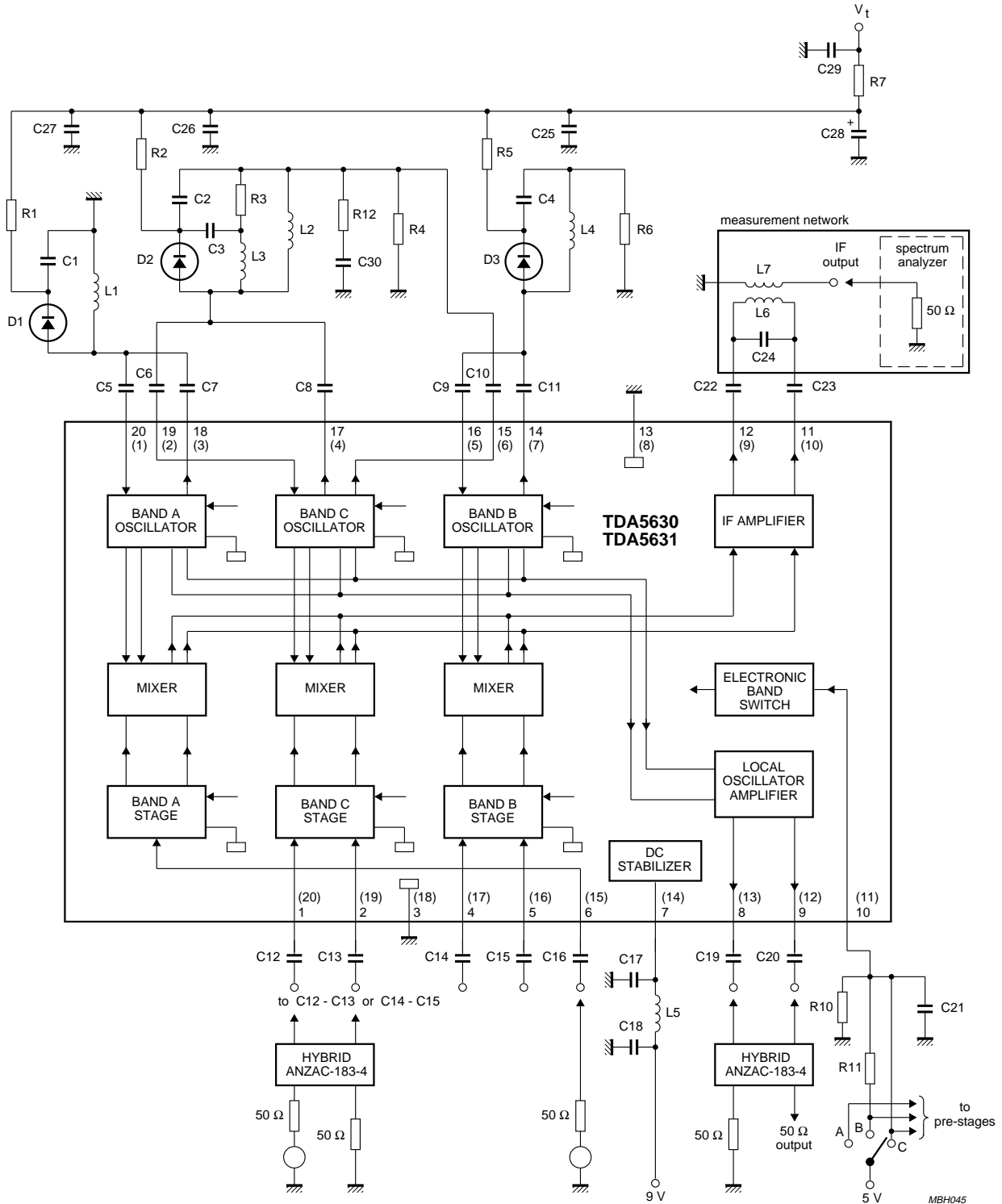

L6, L7 and C24 are only required for measurement purposes; they are not used in a tuner. The pin numbers in parenthesis represent the TDA5631.

Fig.12 Measurement circuit.

9 V VHF, hyperband and UHF mixer/oscillator for TV and VCR 3-band tuners

TDA5630; TDA5631

Component values for measurement circuit

Table 1 Capacitors (all SMD and NP0 except C28)

COMPONENT	VALUE
C1	82 pF
C2	5.6 pF
C3	100 pF
C4	150 pF
C5	2.2 pF
C6	1 pF
C7	2.2 pF
C8	1 pF
C9	1.8 pF
C10	2.2 pF
C11	3.9 pF
C12	1 nF
C13	1 nF
C14	1 nF
C15	1 nF
C16	1 nF
C17	1.5 nF
C18	1.5 nF
C19	1 nF
C20	1 nF
C21	1.5 nF
C22	1 nF
C23	1 nF
C24	18 pF
C25	1.5 nF
C26	1.5 nF
C27	1.5 nF
C28	1 μ F; 40 V electrolytic
C29	1.5 nF
C30	0.56 pF

Table 2 Resistors (all SMD)

COMPONENT	VALUE
R1	47 k Ω
R2	22 k Ω
R3	2.2 k Ω
R4	22 k Ω
R5	47 k Ω

COMPONENT	VALUE
R6	22 Ω
R7	1 k Ω
R10	15 k Ω
R11	22 k Ω
R12	470 Ω

Table 3 Diodes and IC

COMPONENT	VALUE
D1	BB911
D2	BB405 or BB215
D3	BB909 or BB219
IC	TDA5630T
	TDA5630M
	TDA5631T
	TDA5631M

Table 4 Coils (wire size 0.4 mm)

COMPONENT	VALUE
L1	7.5 turns; dia. 3 mm
L2	2.5 turns; dia. 3 mm
L3	1.5 turns; dia. 2.5 mm
L4	1.5 turns; dia. 4 mm
L5	4.7 μ H; choke coil

Table 5 Transformers; note 1

COMPONENT	VALUE
L6	2 \times 5 turns
L7	2 turns

Note

1. Coil type: TOKO 7 kN; material: 113 kN; screw core 03-0093; pot core 04-0026.

9 V VHF, hyperband and UHF
 mixer/oscillator for TV and VCR 3-band tuners

TDA5630;
 TDA5631

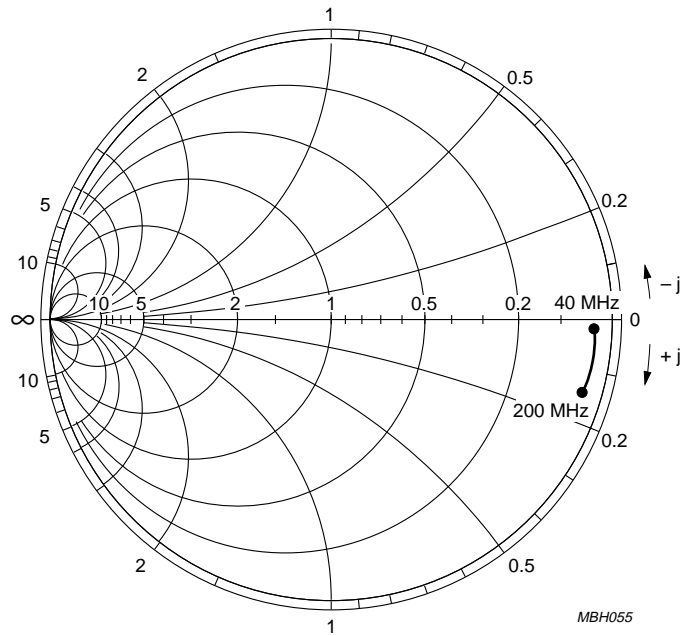

Fig.13 Input admittance (S11) of the band A mixer input (40 to 200 MHz); Y chart.

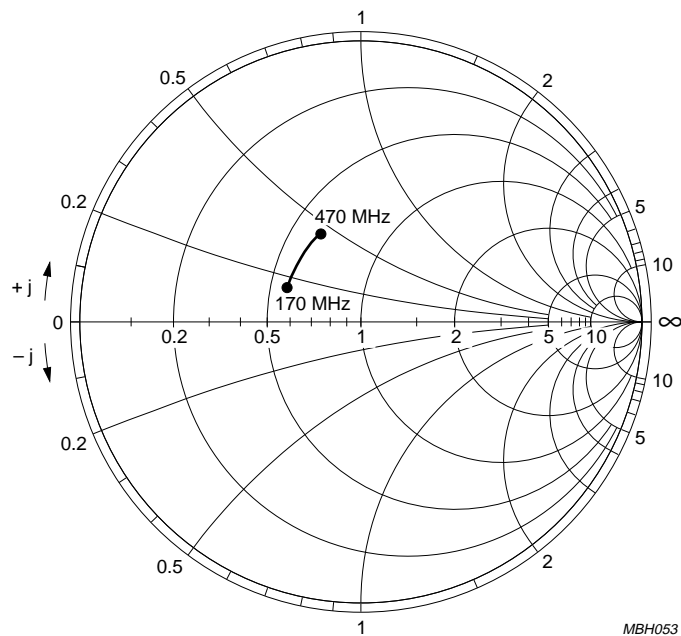

Fig.14 Input impedance (S11) of the band B mixer input (170 to 470 MHz); Z chart.

9 V VHF, hyperband and UHF
 mixer/oscillator for TV and VCR 3-band tuners

TDA5630;
 TDA5631

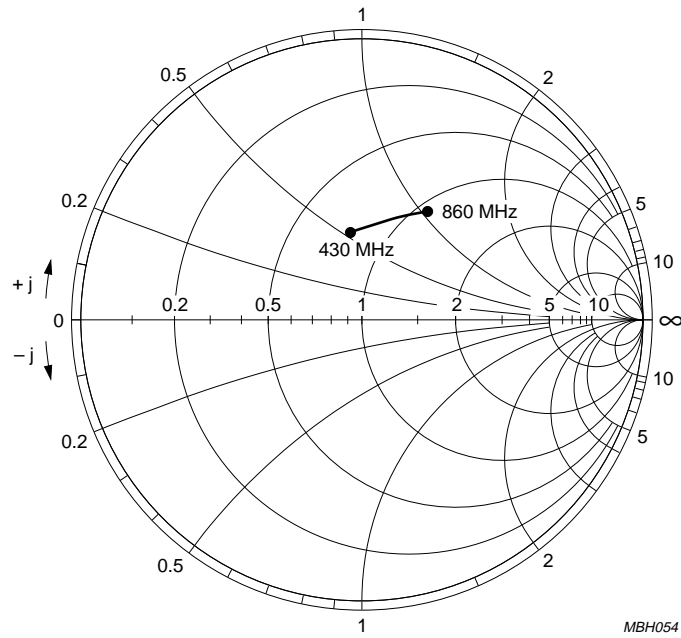

Fig.15 Input impedance (S11) of the band C mixer input (430 to 860 MHz); Z chart.

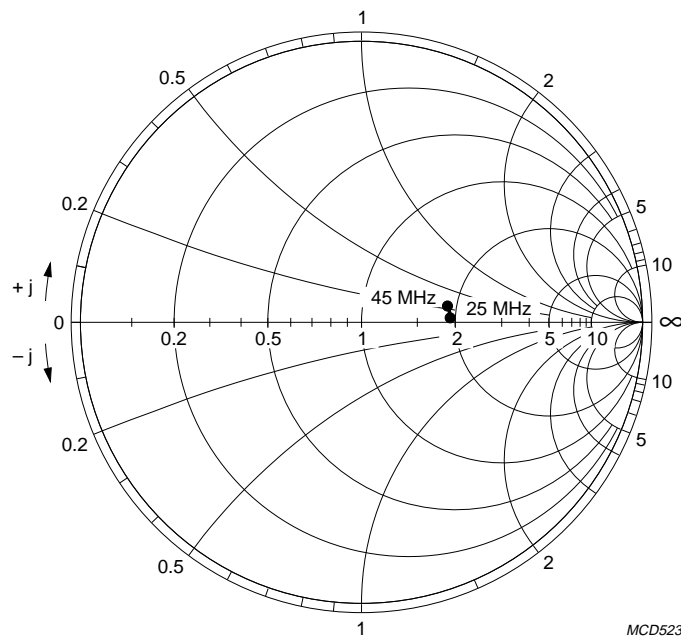

Fig.16 Output impedance (S22) of the IF amplifier (25 to 45 MHz); Z chart.

9 V VHF, hyperband and UHF
 mixer/oscillator for TV and VCR 3-band tuners

TDA5630;
 TDA5631

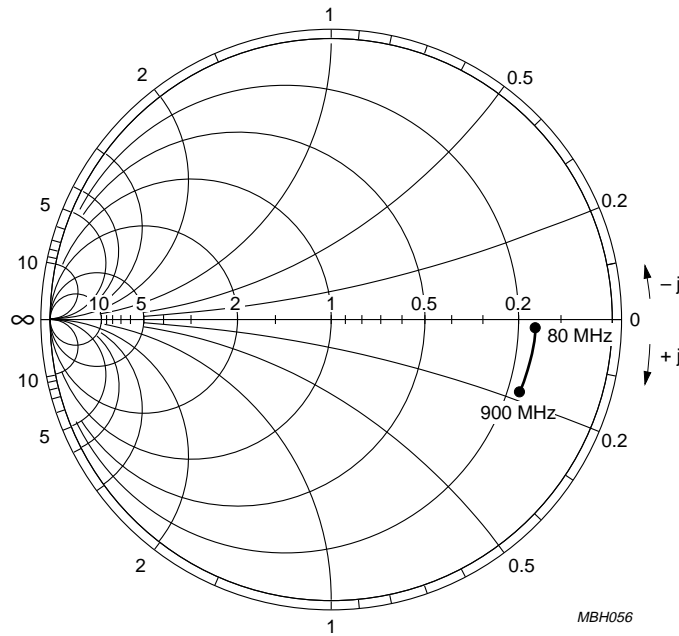

Fig.17 Output admittance (S22) of the LO output (80 to 900 MHz); Y chart.

INTERNAL PIN CONFIGURATION

SYMBOL	PIN		DESCRIPTION	AVERAGE DC VOLTAGE IN (V) MEASURED IN CIRCUIT OF Fig.12		
	TDA5630	TDA5631		BAND A	BAND B	BAND C
CIN1	1	20		NR ⁽¹⁾	NR ⁽¹⁾	2.2
CIN2	2	19		NR ⁽¹⁾	NR ⁽¹⁾	2.2
RFGND	3	18		0.0	0.0	0.0

9 V VHF, hyperband and UHF
 mixer/oscillator for TV and VCR 3-band tuners

TDA5630;
 TDA5631

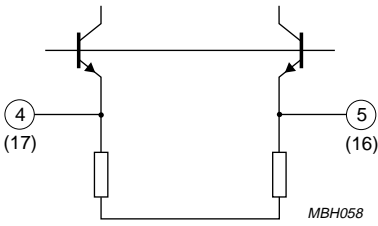
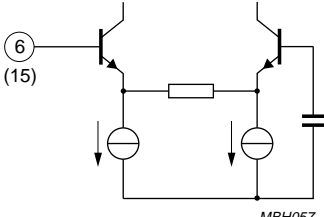
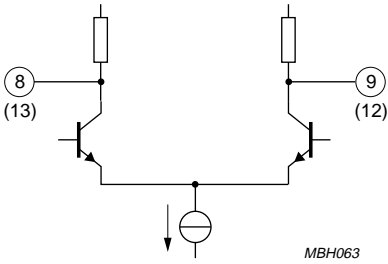
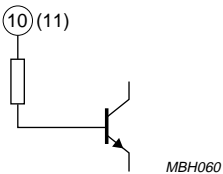
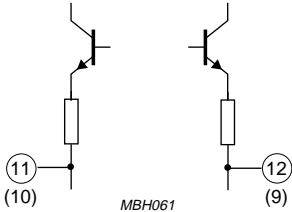
SYMBOL	PIN		DESCRIPTION	AVERAGE DC VOLTAGE IN (V) MEASURED IN CIRCUIT OF Fig.12		
	TDA5630	TDA5631		BAND A	BAND B	BAND C
BIN1	4	17	 <p>MBH058</p>	NR ⁽¹⁾	2.2	NR ⁽¹⁾
BIN2	5	16		NR ⁽¹⁾	2.2	NR ⁽¹⁾
AIN	6	15	 <p>MBH057</p>	2.2	NR ⁽¹⁾	NR ⁽¹⁾
V _P	7	14	supply voltage	9.0	9.0	9.0
LOOUT1	8	13	 <p>MBH063</p>	7.3	7.3	7.3
LOOUT2	9	12		7.3	7.3	7.3
BS	10	11	 <p>MBH060</p>	0.0	2.0	5.0
IFOUT1	11	10	 <p>MBH061</p>	4.0	4.0	4.0
IFOUT2	12	9		4.0	4.0	4.0

9 V VHF, hyperband and UHF
 mixer/oscillator for TV and VCR 3-band tuners

TDA5630;
 TDA5631

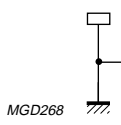
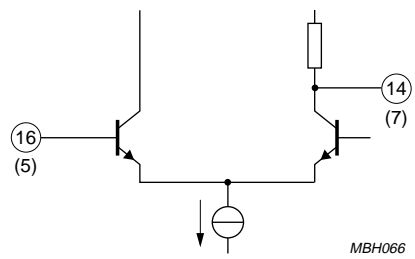
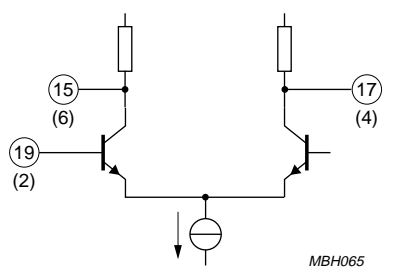
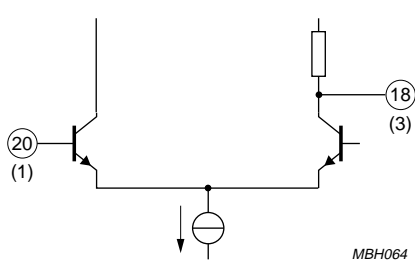
SYMBOL	PIN		DESCRIPTION	AVERAGE DC VOLTAGE IN (V) MEASURED IN CIRCUIT OF Fig.12		
	TDA5630	TDA5631		BAND A	BAND B	BAND C
GND	13	8		0	0	0
BOSCOC	14	7		NR ⁽¹⁾	3.6	NR ⁽¹⁾
BOSCIB	16	5		NR ⁽¹⁾	2.3	NR ⁽¹⁾
COSCOC 1	15	6		NR ⁽¹⁾	NR ⁽¹⁾	4.4
COSCOC 2	17	4		NR ⁽¹⁾	NR ⁽¹⁾	4.4
COSCIB	19	2		NR ⁽¹⁾	NR ⁽¹⁾	2.3
AOSCOC	18	3		4.0	NR ⁽¹⁾	NR ⁽¹⁾
AOSCIB	20	1		2.2	NR ⁽¹⁾	NR ⁽¹⁾

Note

1. NR = not relevant.

9 V VHF, hyperband and UHF
 mixer/oscillator for TV and VCR 3-band tuners

TDA5630;
 TDA5631

PACKAGE OUTLINES

SO20: plastic small outline package; 20 leads; body width 7.5 mm

SOT163-1

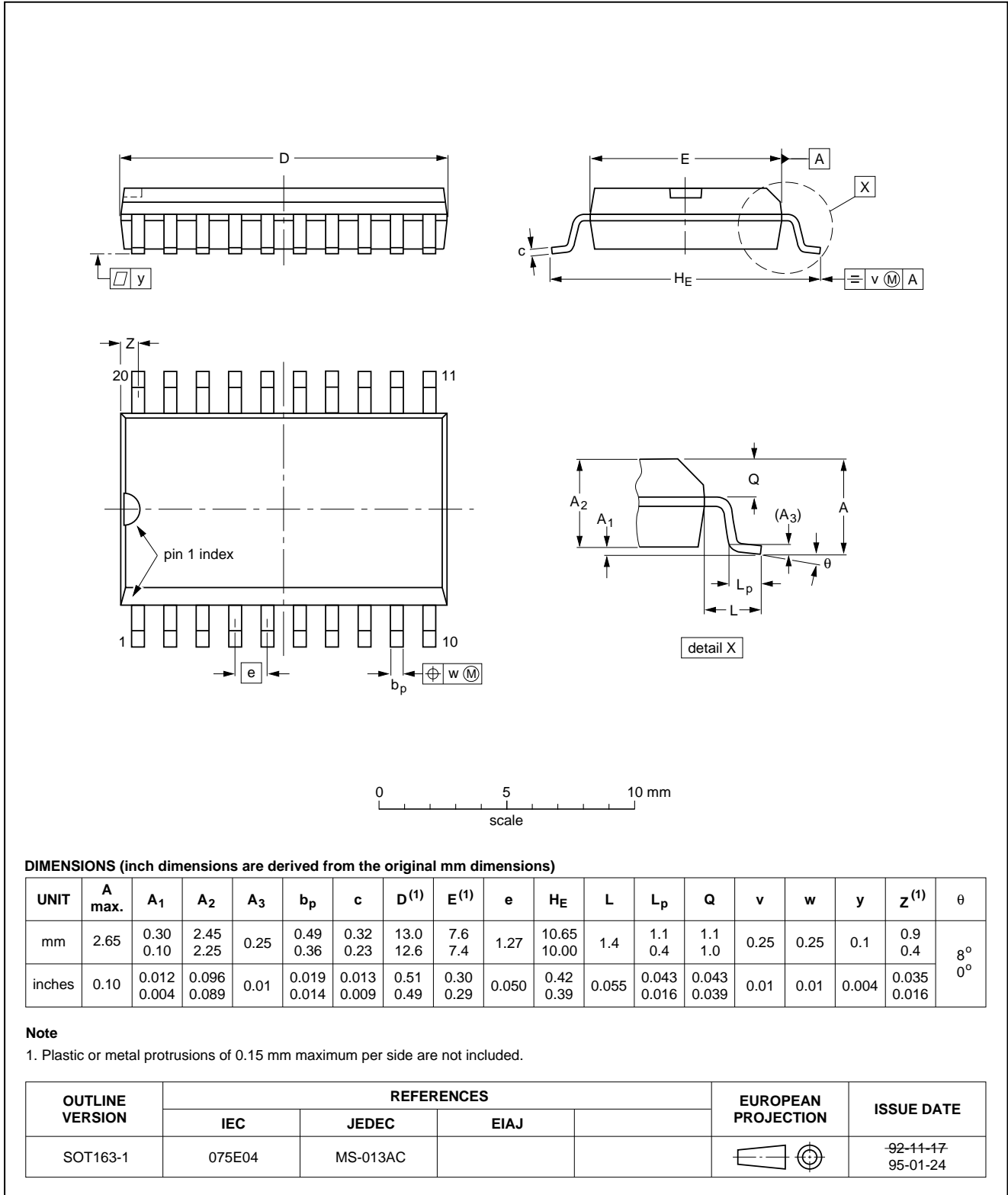

9 V VHF, hyperband and UHF
 mixer/oscillator for TV and VCR 3-band tuners

TDA5630;
 TDA5631

SSOP20: plastic shrink small outline package; 20 leads; body width 4.4 mm

SOT266-1

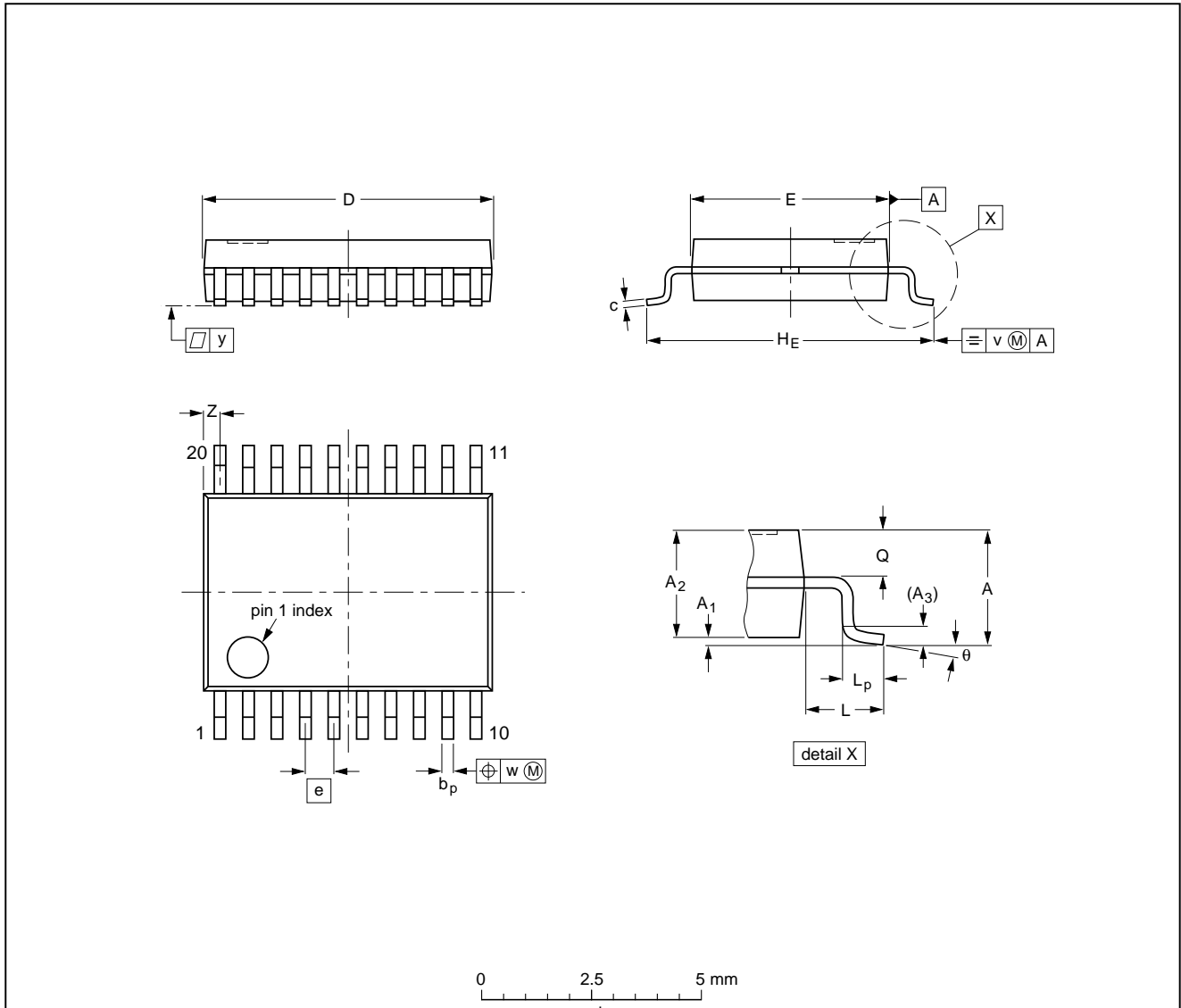

DIMENSIONS (mm are the original dimensions)

UNIT	A max.	A ₁	A ₂	A ₃	b _p	c	D ⁽¹⁾	E ⁽¹⁾	e	H _E	L	L _p	Q	v	w	y	Z ⁽¹⁾	θ
mm	1.5	0.15 0	1.4 1.2	0.25	0.32 0.20	0.20 0.13	6.6 6.4	4.5 4.3	0.65	6.6 6.2	1.0	0.75 0.45	0.65 0.45	0.2	0.13	0.1	0.48 0.18	10° 0°

Note

1. Plastic or metal protrusions of 0.20 mm maximum per side are not included.

OUTLINE VERSION	REFERENCES				EUROPEAN PROJECTION	ISSUE DATE
	IEC	JEDEC	EIAJ			
SOT266-1						90-04-05 95-02-25

9 V VHF, hyperband and UHF mixer/oscillator for TV and VCR 3-band tuners

TDA5630;
TDA5631

SOLDERING

Introduction

There is no soldering method that is ideal for all IC packages. Wave soldering is often preferred when through-hole and surface mounted components are mixed on one printed-circuit board. However, wave soldering is not always suitable for surface mounted ICs, or for printed-circuits with high population densities. In these situations reflow soldering is often used.

This text gives a very brief insight to a complex technology. A more in-depth account of soldering ICs can be found in our "IC Package Databook" (order code 9398 652 90011).

Reflow soldering

Reflow soldering techniques are suitable for all SO and SSOP packages.

Reflow soldering requires solder paste (a suspension of fine solder particles, flux and binding agent) to be applied to the printed-circuit board by screen printing, stencilling or pressure-syringe dispensing before package placement.

Several techniques exist for reflowing; for example, thermal conduction by heated belt. Dwell times vary between 50 and 300 seconds depending on heating method. Typical reflow temperatures range from 215 to 250 °C.

Preheating is necessary to dry the paste and evaporate the binding agent. Preheating duration: 45 minutes at 45 °C.

Wave soldering

SO

Wave soldering techniques can be used for all SO packages if the following conditions are observed:

- A double-wave (a turbulent wave with high upward pressure followed by a smooth laminar wave) soldering technique should be used.
- The longitudinal axis of the package footprint must be parallel to the solder flow.
- The package footprint must incorporate solder thieves at the downstream end.

SSOP

Wave soldering is **not** recommended for SSOP packages. This is because of the likelihood of solder bridging due to closely-spaced leads and the possibility of incomplete solder penetration in multi-lead devices.

If wave soldering cannot be avoided, the following conditions must be observed:

- **A double-wave (a turbulent wave with high upward pressure followed by a smooth laminar wave) soldering technique should be used.**
- **The longitudinal axis of the package footprint must be parallel to the solder flow and must incorporate solder thieves at the downstream end.**

METHOD (SO AND SSOP)

During placement and before soldering, the package must be fixed with a droplet of adhesive. The adhesive can be applied by screen printing, pin transfer or syringe dispensing. The package can be soldered after the adhesive is cured.

Maximum permissible solder temperature is 260 °C, and maximum duration of package immersion in solder is 10 seconds, if cooled to less than 150 °C within 6 seconds. Typical dwell time is 4 seconds at 250 °C.

A mildly-activated flux will eliminate the need for removal of corrosive residues in most applications.

Repairing soldered joints

Fix the component by first soldering two diagonally-opposite end leads. Use only **a low voltage** soldering iron (**less than 24 V**) applied to the flat part of the lead. Contact time must be limited to 10 seconds at up to 300 °C. When using a dedicated tool, all other leads can be soldered in one operation within 2 to 5 seconds between 270 and 320 °C.

9 V VHF, hyperband and UHF
mixer/oscillator for TV and VCR 3-band tuners

TDA5630;
TDA5631

DEFINITIONS

Data sheet status	
Objective specification	This data sheet contains target or goal specifications for product development.
Preliminary specification	This data sheet contains preliminary data; supplementary data may be published later.
Product specification	This data sheet contains final product specifications.
Limiting values	
Limiting values given are in accordance with the Absolute Maximum Rating System (IEC 134). Stress above one or more of the limiting values may cause permanent damage to the device. These are stress ratings only and operation of the device at these or at any other conditions above those given in the Characteristics sections of the specification is not implied. Exposure to limiting values for extended periods may affect device reliability.	
Application information	
Where application information is given, it is advisory and does not form part of the specification.	

LIFE SUPPORT APPLICATIONS

These products are not designed for use in life support appliances, devices, or systems where malfunction of these products can reasonably be expected to result in personal injury. Philips customers using or selling these products for use in such applications do so at their own risk and agree to fully indemnify Philips for any damages resulting from such improper use or sale.

9 V VHF, hyperband and UHF
mixer/oscillator for TV and VCR 3-band tuners

TDA5630;
TDA5631

NOTES

9 V VHF, hyperband and UHF
mixer/oscillator for TV and VCR 3-band tuners

TDA5630;
TDA5631

NOTES

9 V VHF, hyperband and UHF
mixer/oscillator for TV and VCR 3-band tuners

TDA5630;
TDA5631

NOTES

Philips Semiconductors – a worldwide company

Argentina: see South America

Australia: 34 Waterloo Road, NORTH RYDE, NSW 2113,
Tel. (02) 805 4455, Fax. (02) 805 4466

Austria: Computerstr. 6, A-1101 WIEN, P.O. Box 213,
Tel. (01) 60 101-1256, Fax. (01) 60 101-1250

Belarus: Hotel Minsk Business Center, Bld. 3, r. 1211,
Volodarski Str. 6, 220050 MINSK,
Tel. (172) 200 733, Fax. (172) 200 773

Belgium: see The Netherlands

Brazil: see South America

Bulgaria: Philips Bulgaria Ltd., Energoproject, 15th floor,
51 James Bourchier Blvd., 1407 SOFIA,
Tel. (359) 2 689 211, Fax. (359) 2 689 102

Canada: PHILIPS SEMICONDUCTORS/COMPONENTS:
Tel. (800) 234-7381, Fax. (708) 296-8556

Chile: see South America

China/Hong Kong: 501 Hong Kong Industrial Technology Centre,
72 Tat Chee Avenue, Kowloon Tong, HONG KONG,
Tel. (852) 2319 7888, Fax. (852) 2319 7700

Colombia: see South America

Czech Republic: see Austria

Denmark: Prags Boulevard 80, PB 1919, DK-2300
COPENHAGEN S, Tel. (032) 88 2636, Fax. (031) 57 1949

Finland: Sinikalliontie 3, FIN-02630 ESPOO,
Tel. (358) 0-615 800, Fax. (358) 0-61580 920

France: 4 Rue du Port-aux-Vins, BP317,
92156 SURESNES Cedex,
Tel. (01) 4099 6161, Fax. (01) 4099 6427

Germany: P.O. Box 10 51 40, 20035 HAMBURG,
Tel. (040) 23 53 60, Fax. (040) 23 53 63 00

Greece: No. 15, 25th March Street, GR 17778 TAVROS,
Tel. (01) 4894 339/4894 911, Fax. (01) 4814 240

Hungary: see Austria

India: Philips INDIA Ltd, Shivsagar Estate, A Block,
Dr. Annie Bessant Rd. Worli, BOMBAY 400 018
Tel. (022) 4938 541, Fax. (022) 4938 722

Indonesia: see Singapore

Ireland: Newstead, Clonskeagh, DUBLIN 14,
Tel. (01) 7640 000, Fax. (01) 7640 200

Israel: RAPAC Electronics, 7 Kehilat Saloniki St, TEL AVIV 61180,
Tel. (03) 645 04 44, Fax. (03) 648 10 07

Italy: PHILIPS SEMICONDUCTORS,
Piazza IV Novembre 3, 20124 MILANO,
Tel. (0039) 2 6752 2531, Fax. (0039) 2 6752 2557

Japan: Philips Bldg 13-37, Kohnan 2-chome, Minato-ku,
TOKYO 108, Tel. (03) 3740 5130, Fax. (03) 3740 5077

Korea: Philips House, 260-199 Itaewon-dong,
Yongsan-ku, SEOUL, Tel. (02) 709-1412, Fax. (02) 709-1415

Malaysia: No. 76 Jalan Universiti, 46200 PETALING JAYA,
SELANGOR, Tel. (03) 750 5214, Fax. (03) 757 4880

Mexico: 5900 Gateway East, Suite 200, EL PASO,
TEXAS 79905, Tel. 9-5(800) 234-7831, Fax. (708) 296-8556

Middle East: see Italy

Netherlands: Postbus 90050, 5600 PB EINDHOVEN, Bldg. VB,
Tel. (040) 2783749, Fax. (040) 2788399

New Zealand: 2 Wagener Place, C.P.O. Box 1041, AUCKLAND,
Tel. (09) 849-4160, Fax. (09) 849-7811

Norway: Box 1, Manglerud 0612, OSLO,
Tel. (022) 74 8000, Fax. (022) 74 8341

Philippines: PHILIPS SEMICONDUCTORS PHILIPPINES Inc.,
106 Valero St. Salcedo Village, P.O. Box 2108 MCC,
MAKATI, Metro MANILA,
Tel. (63) 2 816 6380, Fax. (63) 2 817 3474

Poland: Ul. Lukiska 10, PL 04-123 WARSZAWA,
Tel. (022) 612 2831, Fax. (022) 612 2327

Portugal: see Spain

Romania: see Italy

Singapore: Lorong 1, Toa Payoh, SINGAPORE 1231,
Tel. (65) 350 2000, Fax. (65) 251 6500

Slovakia: see Austria

Slovenia: see Italy

South Africa: S.A. PHILIPS Pty Ltd.,
195-215 Main Road Martindale, 2092 JOHANNESBURG,
P.O. Box 7430 Johannesburg 2000,
Tel. (011) 470-5911, Fax. (011) 470-5494

South America: Rua do Rocio 220 - 5th floor, Suite 51,
CEP: 04552-903-SÃO PAULO-SP, Brazil,
P.O. Box 7383 (01064-970),
Tel. (011) 821-2333, Fax. (011) 829-1849

Spain: Balmes 22, 08007 BARCELONA,
Tel. (03) 301 6312, Fax. (03) 301 4107

Sweden: Kottbygatan 7, Akalla. S-16485 STOCKHOLM,
Tel. (0) 8-632 2000, Fax. (0) 8-632 2745

Switzerland: Allmendstrasse 140, CH-8027 ZÜRICH,
Tel. (01) 488 2211, Fax. (01) 481 77 30

Taiwan: PHILIPS TAIWAN Ltd., 23-30F, 66,
Chung Hsiao West Road, Sec. 1, P.O. Box 22978,
TAIPEI 100, Tel. (886) 2 382 4443, Fax. (886) 2 382 4444

Thailand: PHILIPS ELECTRONICS (THAILAND) Ltd.,
209/2 Sanpavuth-Bangna Road Prakanong, BANGKOK 10260,
Tel. (66) 2 745-4090, Fax. (66) 2 398-0793

Turkey: Talatpasa Cad. No. 5, 80640 GÜLTEPE/ISTANBUL,
Tel. (0212) 279 2770, Fax. (0212) 282 6707

Ukraine: PHILIPS UKRAINE,
2A Akademika Koroleva str., Office 165, 252148 KIEV,
Tel. 380-44-4760297, Fax. 380-44-4766991

United Kingdom: Philips Semiconductors LTD.,
276 Bath Road, Hayes, MIDDLESEX UB3 5BX,
Tel. (0181) 730-5000, Fax. (0181) 754-8421

United States: 811 East Arques Avenue, SUNNYVALE,
CA 94088-3409, Tel. (800) 234-7381, Fax. (708) 296-8556

Uruguay: see South America

Vietnam: see Singapore

Yugoslavia: PHILIPS, Trg N. Pasic 5/v, 11000 BEOGRAD,
Tel. (381) 11 825 344, Fax. (359) 211 635 777

Internet: <http://www.semiconductors.philips.com/ps/>

For all other countries apply to: Philips Semiconductors,
Marketing & Sales Communications, Building BE-p,
P.O. Box 218, 5600 MD EINDHOVEN, The Netherlands,
Fax. +31-40-2724825

SCDS48

© Philips Electronics N.V. 1996

All rights are reserved. Reproduction in whole or in part is prohibited without the prior written consent of the copyright owner.

The information presented in this document does not form part of any quotation or contract, is believed to be accurate and reliable and may be changed without notice. No liability will be accepted by the publisher for any consequence of its use. Publication thereof does not convey nor imply any license under patent- or other industrial or intellectual property rights.

Printed in The Netherlands

537021/1100/04/pp28
Document order number:

Date of release: 1996 Mar 21
9397 750 00749