

HIGH-POWER & LOW-VOLTAGE AUDIO POWER AMPLIFIER

■ GENERAL DESCRIPTION

The **NJU7084** is an audio power amplifier designed for telephone applications. No external coupling capacitors are required because of the differential outputs. The closed loop gain is adjusted by two external resistors, and a SD pin permit power down with muting the input signal.

The **NJU7084** improves high output power compared with other amplifier.

■ APPLICATION

- Cell Phone, PHS
- Portable Telephone, Wireless Telephone
- White Goods
- Security Alarm
- Monitor

■ FEATURES

- Operating Voltage
- Operating Current
- Supply Current in Shutdown Mode
- Output Power
- Thermal Shutdown Circuit
- C-MOS Technology
- Package Outline

$V^+ = 2.8$ to $5.5V$

$I_{DD1} = 2.5mA$ typ. ($V^+ = 5V, R_L = \infty$, no signal)

$I_{DD1} = 2mA$ typ. ($V^+ = 3V, R_L = \infty$, no signal)

$I_{DD2} = 2\mu A$ max.

$P_0 = 1W$ typ. ($V^+ = 5V, R_L = 8\Omega, THD = 2\%$)

$P_0 = 400mW$ typ. ($V^+ = 3V, R_L = 4\Omega, THD = 2\%$)

VSP8, DMP24

■ PACKAGE OUTLINE



NJU7084R

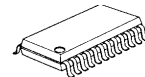

NJU7084M

■ PIN CONFIGURATION & BLOCK DIAGRAM

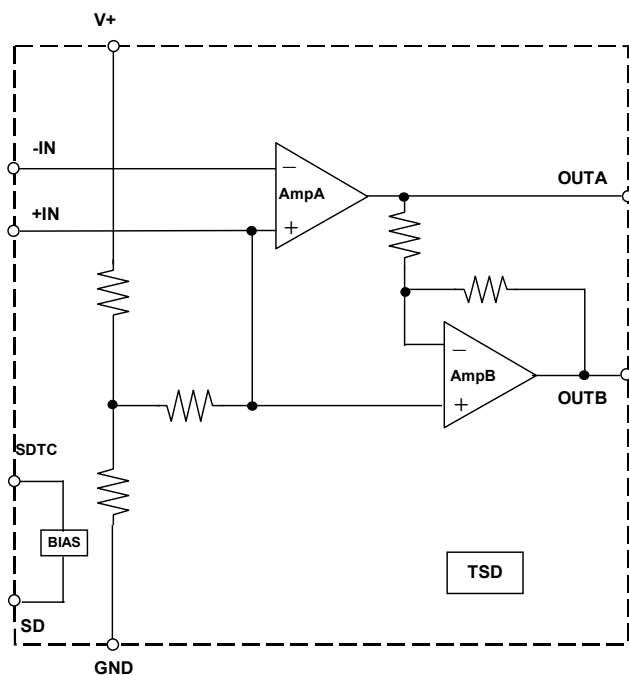

(VSP8)

1. SD
2. SDTC
3. +IN
4. -IN
5. OUTA
6. V^+
7. GND
8. OUTB

(DMP24)

- | | | |
|---------|--------|-----------|
| 1. NC | 9. NC | 17. OUTA |
| 2. NC | 10. NC | 18. V^+ |
| 3. NC | 11. NC | 19. GND |
| 4. NC | 12. NC | 20. OUTB |
| 5. SD | 13. NC | 21. NC |
| 6. SDTC | 14. NC | 22. NC |
| 7. +IN | 15. NC | 23. NC |
| 8. -IN | 16. NC | 24. NC |

NJU7084

www.DataSheet4U.com

■ ABSOLUTE MAXIMUM RATINGS (Ta=25°C)

PARAMETER	SYMBOL	RATINGS	UNIT
Supply Voltage	V ⁺	+7	V
Power Dissipation	P _D	960 * ¹⁾ (VSP8) 1350 * ²⁾ (DMP24)	mW
Output Peak Current	I _{op}	500	mA
Input Voltage Range	V _{IN}	-0.3 to V ⁺ +0.3 * ³⁾	V
Operating Temperature Range	T _{opr}	-40 to +85	°C
Storage Temperature Range	T _{stg}	-40 to +150	°C

*¹⁾ EIA/JEDEC STANDARD Test board (76.2 x 114.3 x 1.6mm, 4layers, FR-4) mounting

*²⁾ EIA/JEDEC STANDARD Test board (76.2 x 114.3 x 1.6mm, 2layers, FR-4) mounting

*³⁾ SD, SDTC, IN+, IN-, OUTA, OUTB terminals.

■ RECOMMENDED OPERATING VOLTAGE RANGE (Ta=25°C)

PARAMETER	SYMBOL	TEST CONDITION	MIN.	TYP.	MAX.	UNIT
Operating Voltage Range	V ⁺	-	2.8	3.0	5.5	V

■ ELECTRICAL CHARACTERISTICS

● Amplifier (Ta=25°C, V⁺=5V, G_v=6dB, f=1kHz, R_L=8Ω, Active)

PARAMETER	SYMBOL	TEST CONDITION	MIN.	TYP.	MAX.	UNIT
Operating Current 1	I _{DD1}	No signal, R _L =∞, Active	-	2.5	6	mA
Operating Current 2	I _{DD2}	No signal, R _L =∞, V _{SD} =0.25V	-	-	2	μA
Output Power	P _{O1}	THD≤2%	0.8	1	-	W
Total Harmonic Distortion (THD+N)	THD	P _O =400mW	-	0.1	-	%
Supply Voltage Rejection Ratio	PSRR	C1=1μF, C2=2.2μF V _{ripple} =100mVrms	45	55	-	dB
Mute Attenuation	MAT	Shutdown	-	70	-	dB
Input Resistance	R _{SD}	SD Terminal	105	150	195	kΩ
Output Offset Voltage	V _{OD}	V _{IN} =0V	-50	-	50	mV

(Ta=25°C, V⁺=3V, G_v=6dB, f=1kHz, R_L=4Ω, Active)

PARAMETER	SYMBOL	TEST CONDITION	MIN.	TYP.	MAX.	UNIT
Operating Current 1	I _{DD1}	No signal, R _L =∞, Active	-	2.0	4	mA
Operating Current 2	I _{DD2}	No signal, R _L =∞, V _{SD} =0.25V	-	-	2	μA
Output Power	P _{O1}	THD≤2%	320	400	-	mW
Total Harmonic Distortion (THD+N)	THD	P _O =200mW	-	0.1	-	%
Supply Voltage Rejection Ratio	PSRR	C1=1μF, C2=2.2μF V _{ripple} =100mVrms	-	55	-	dB
Mute Attenuation	MAT	Shutdown	-	70	-	dB
Output Offset Voltage	V _{OD}	V _{IN} =0V	-50	-	50	mV

V_{SD}: SD Terminal Voltage

● Mode Control (Ta=25°C)

PARAMETER	SYMBOL	TEST CONDITION	MIN.	TYP.	MAX.	UNIT
High Level Input Voltage	V _{IH}	-	0.7V ⁺	-	V ⁺	V
Low Level Input Voltage	V _{IL}	-	0	-	0.25	

■ CONTROL TERMINAL EXPLANATION

MODE	CONTROL SIGNAL (SD Terminal)	STATUS
Shutdown	L(=V _{IL})	IC is standby.
Active	H(=V _{IH})	IC is active.

TEST CIRCUIT

TEST CIRCUIT1 (Operating Current I_{DD1} , I_{DD2})

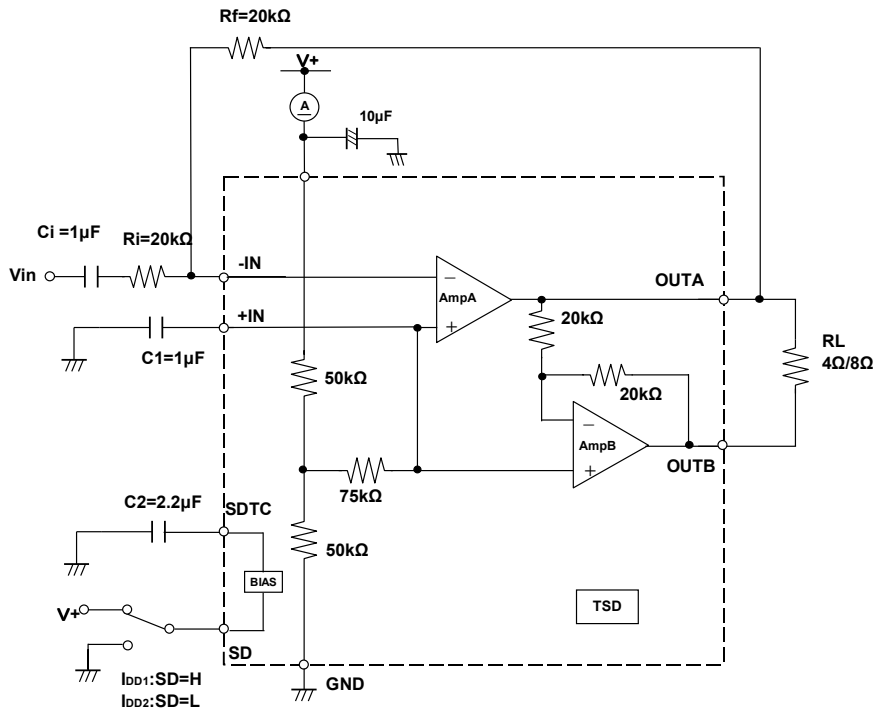

TEST CIRCUIT2 (Output Power P_O , Total Harmonic Distortion THD)

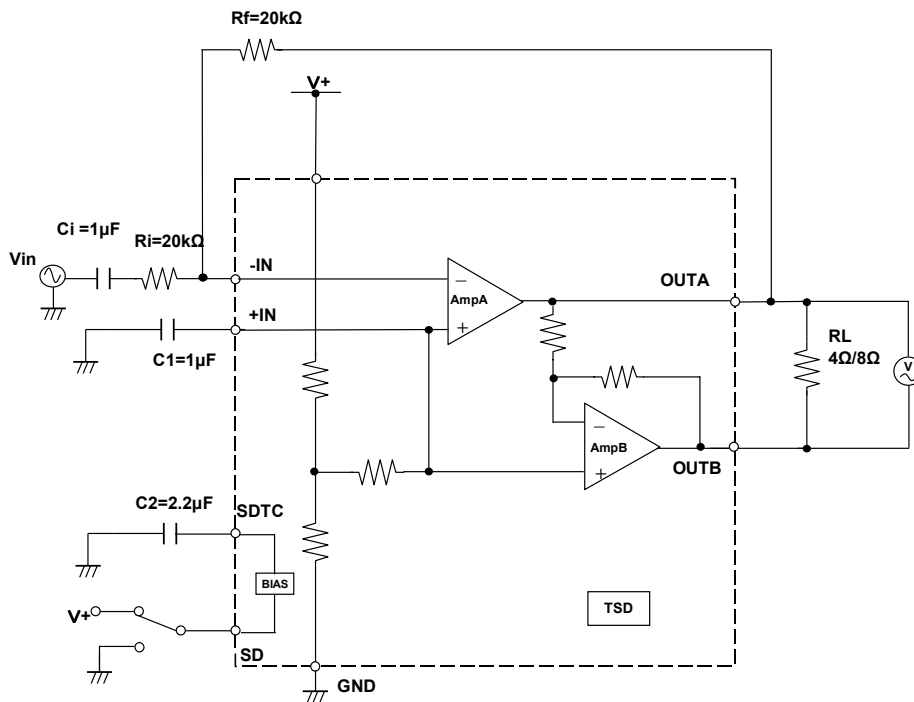

TEST CIRCUIT

TEST CIRCUIT3 (Supply Voltage Rejection Ratio PSRR)

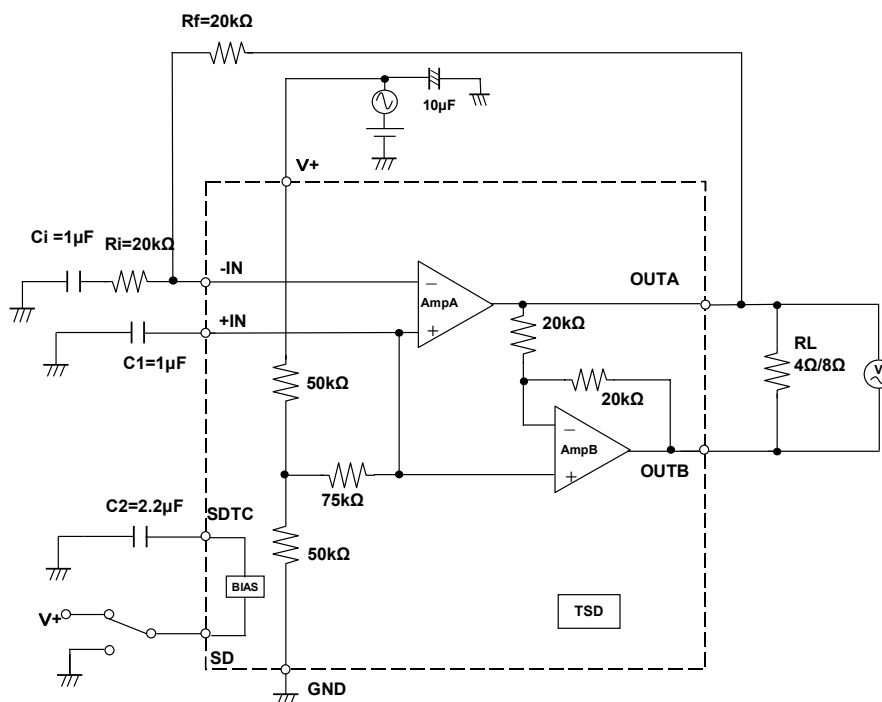

TEST CIRCUIT4 (Output Offset Voltage V_{OD})

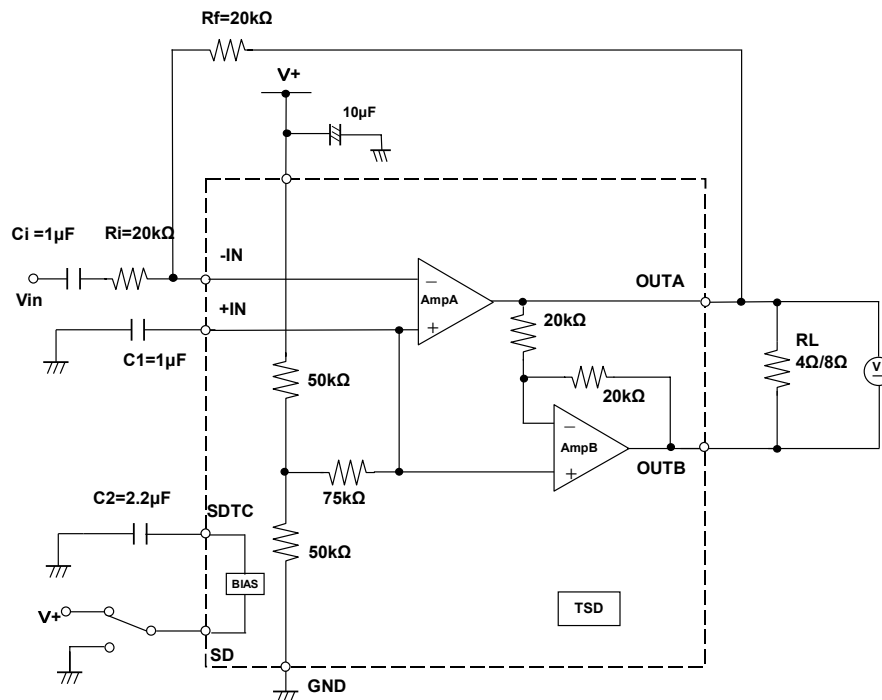

■ EQUIVALENT CIRCUIT

PIN No.		SYMBOL	EQUIVALENT CIRCUIT	TERMINAL VOLTAGE	Note
DMP 24	VSP 8				
5	1	SD		-	
6	2	SDTC		$2 * V^+ / 3$	
7	3	+IN		$V^+ / 2$	
8	4	-IN		$V^+ / 2$	

NJU7084

www.DataSheet4U.com

■ EQUIVALENT CIRCUIT

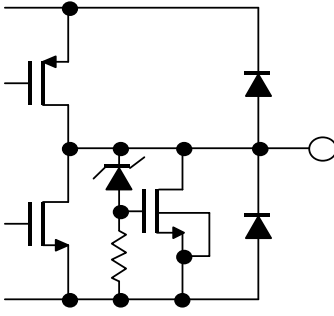
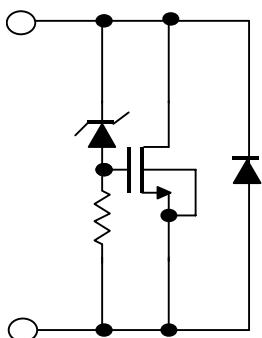
PIN No.		SYMBOL	EQUIVALENT CIRCUIT	TERMINAL VOLTAGE	Note
DMP 24	VSP 8				
17 20	5 8	OUTA OUTB		$V^+/2$	
18 19	6 7	V^+ GND		-	

APPLICATION CIRCUIT

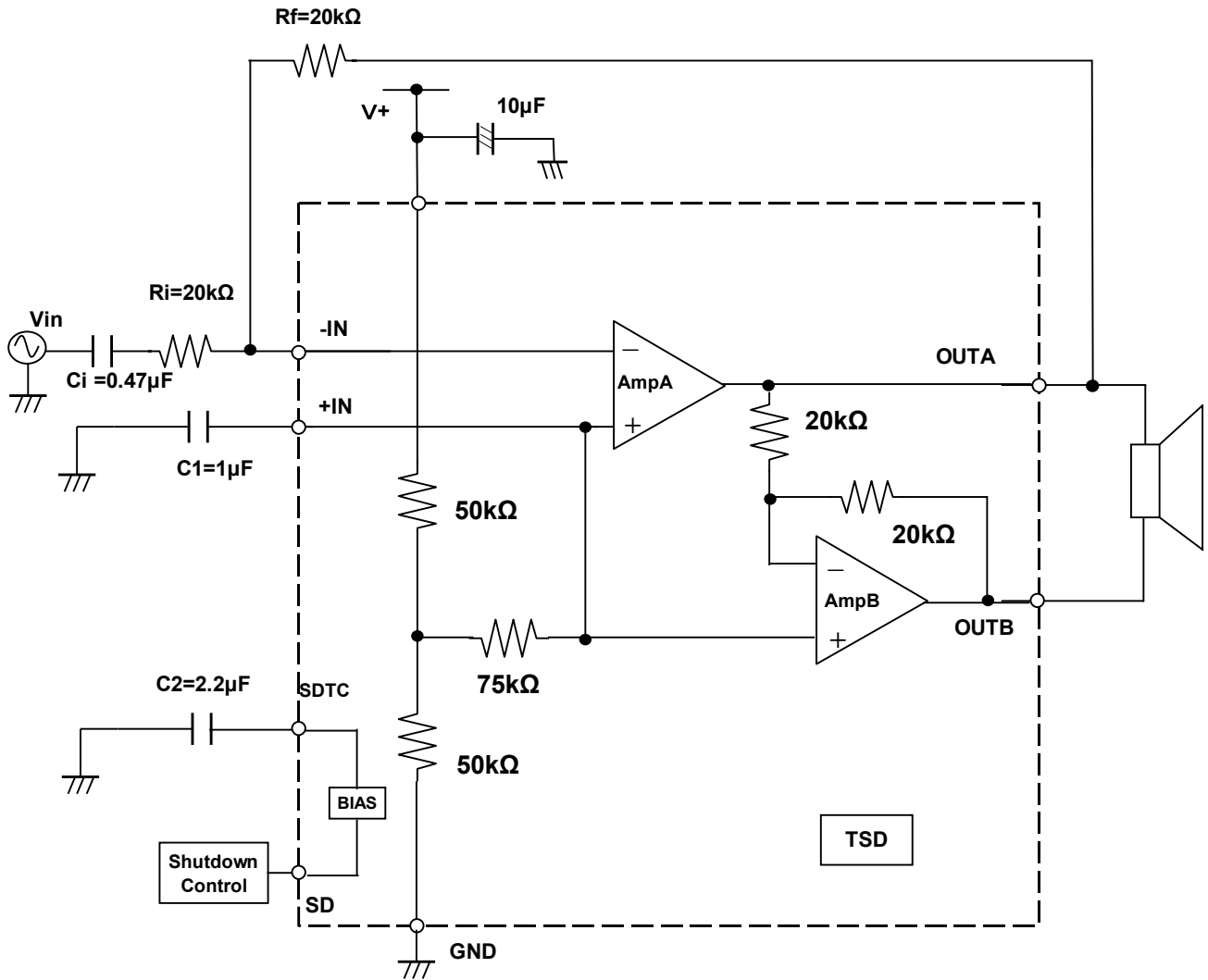

TYPICAL CHARACTERISTICS

Supply Current vs Supply Voltage
RL=OPEN, Ta=25°C

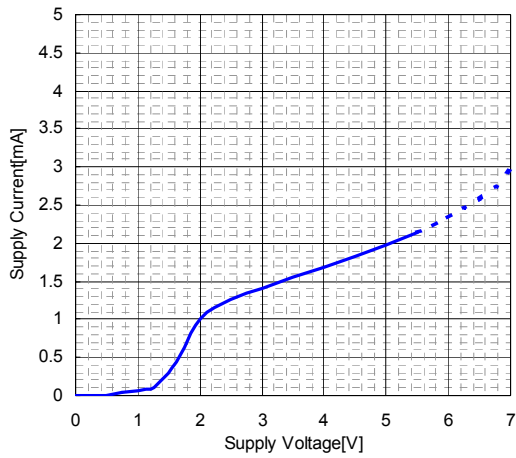

Supply Current vs Temperature
V+=3V, Gv=6dB, RL=OPEN

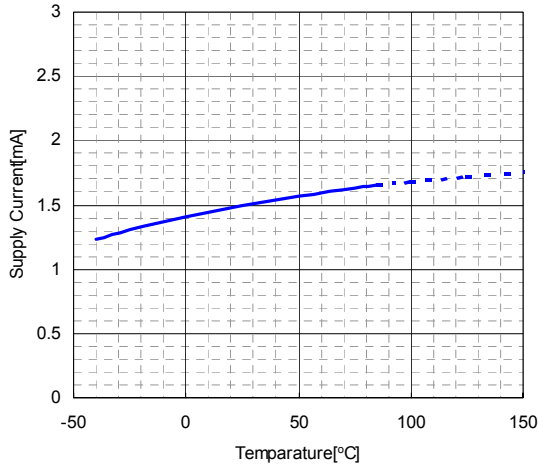

Supply Current vs Temperature
V+=5V, Gv=6dB, RL=OPEN

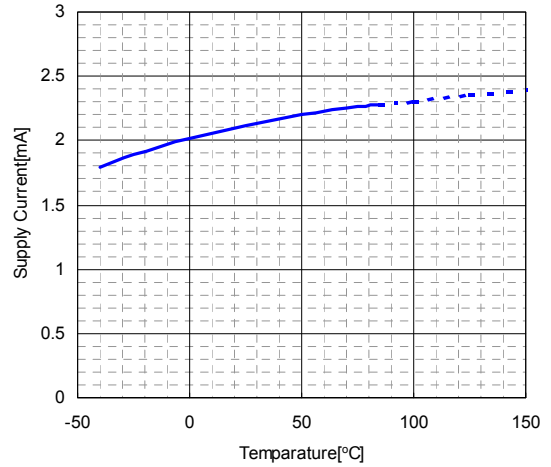

Supply Current vs Temperature(STANBY)
V+=3V, RL=OPEN, VSD=0.25V

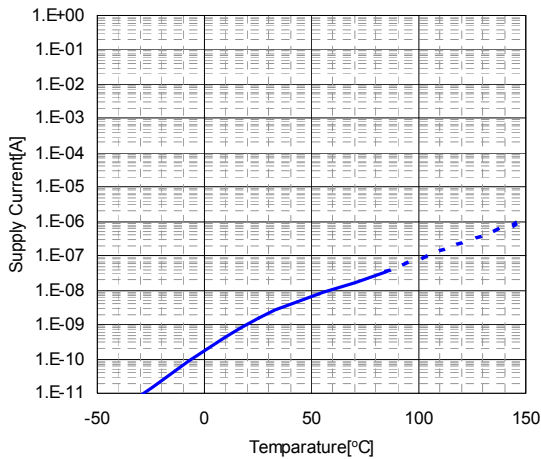

Supply Current vs Temperature(STANBY)
V+=5V, RL=OPEN, VSD=0.25V

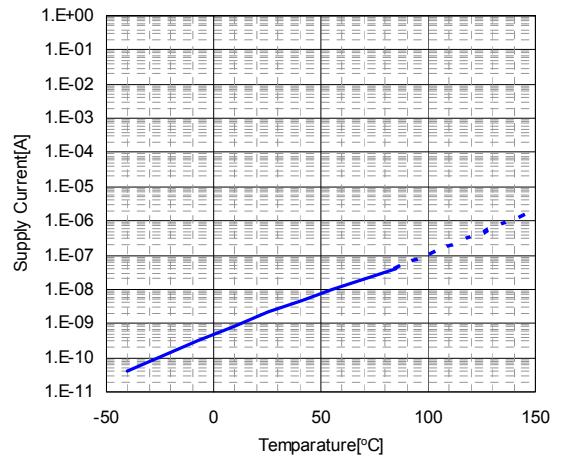

TYPICAL CHARACTERISTICS

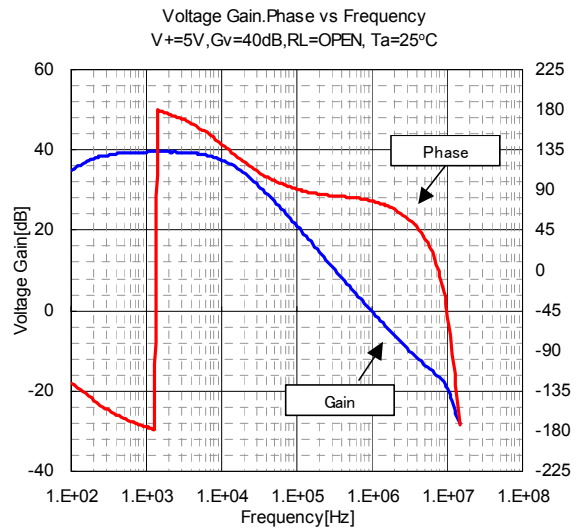
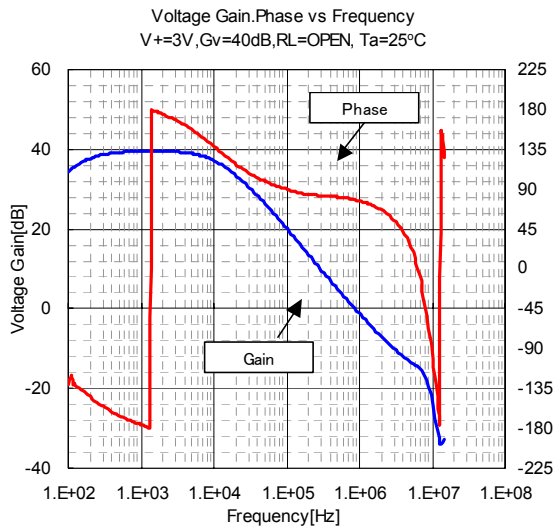
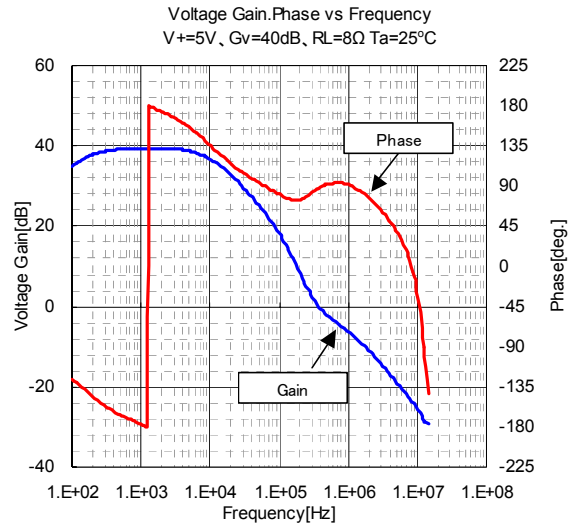
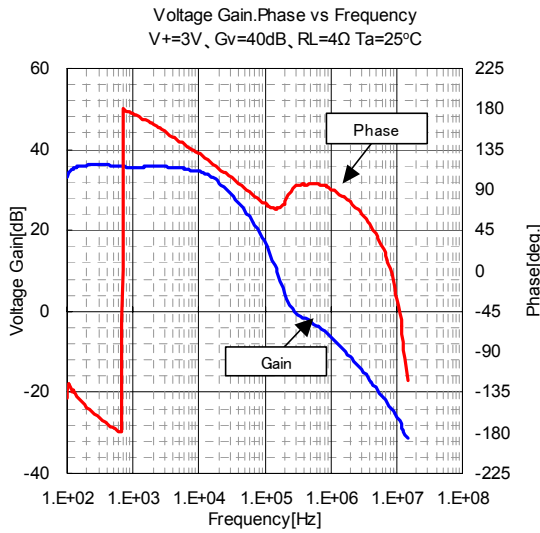
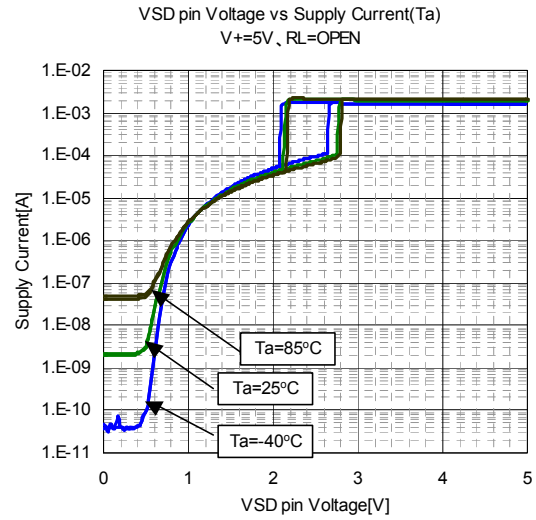
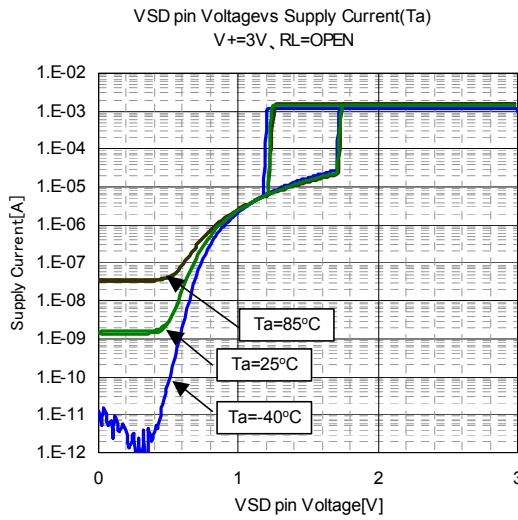

TYPICAL CHARACTERISTICS

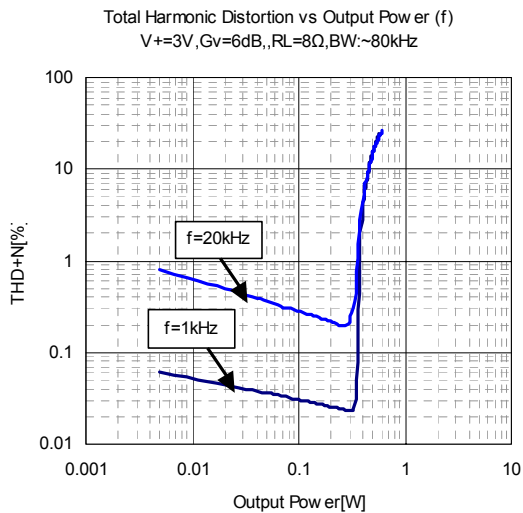
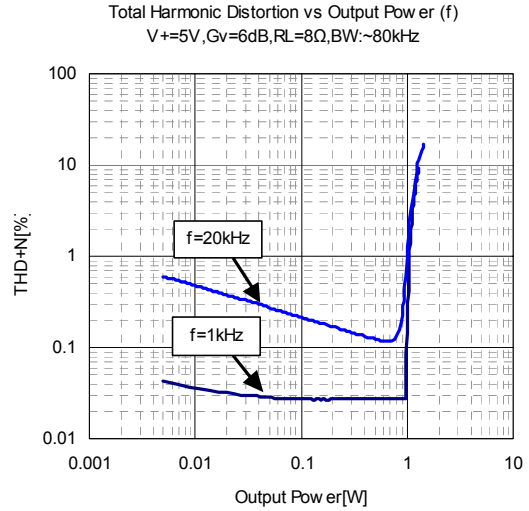
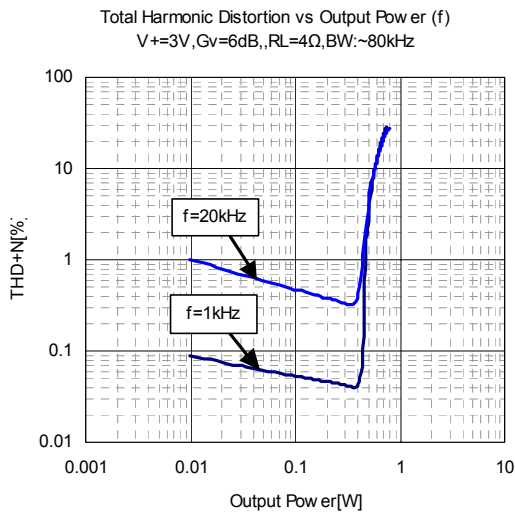
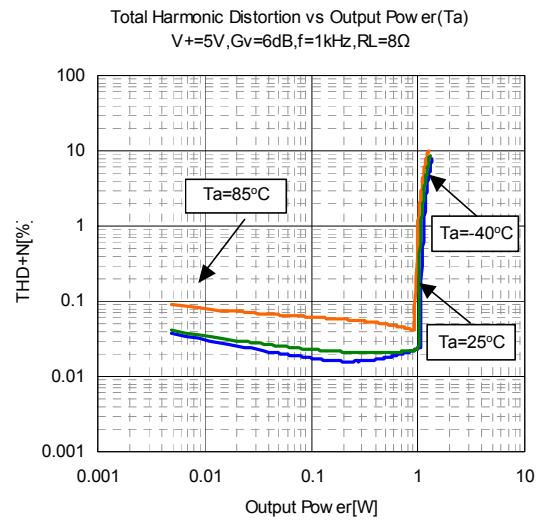
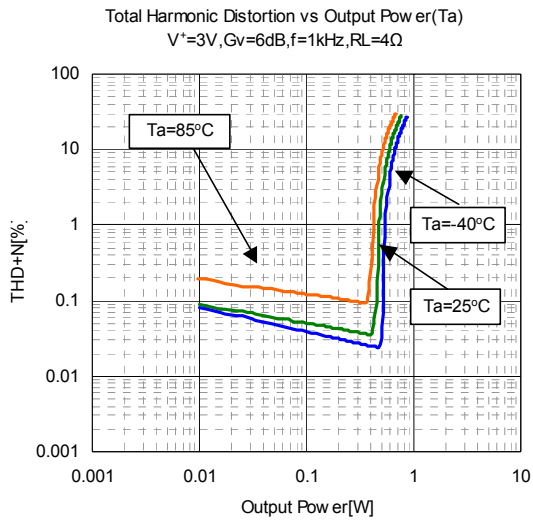

TYPICAL CHARACTERISTICS

Output Voltage vs Supply Voltage (THD)
RL=4Ω, Ta=25°C

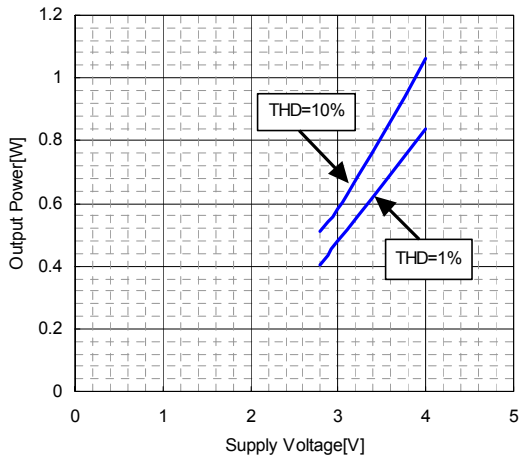

Output Voltage vs Supply Voltage (THD)
RL=8Ω, Ta=25°C

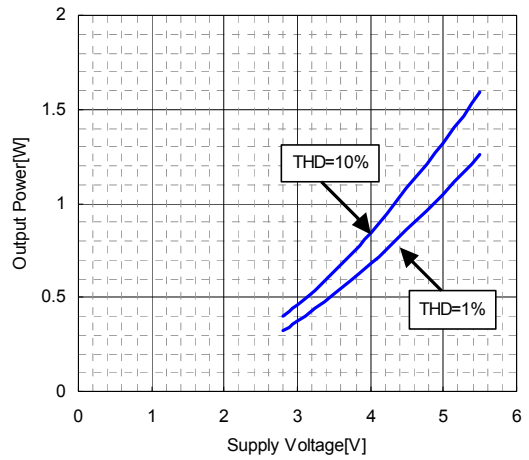

Power Dissipation vs Output Power
V+=5V, Gv=6dB, RL=8Ω, Ta=25°C

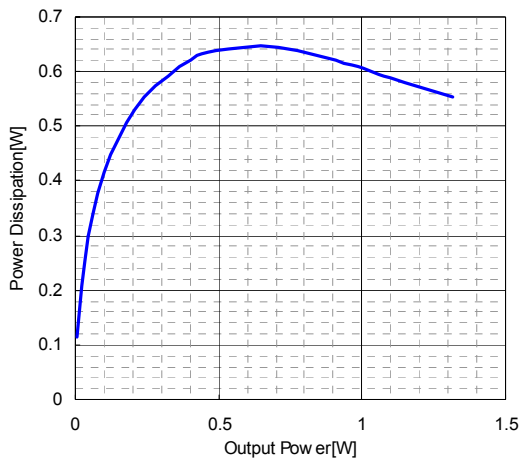

Power Dissipation vs Output Power (RL)
V+=3V, Gv=6dB, Ta=25°C

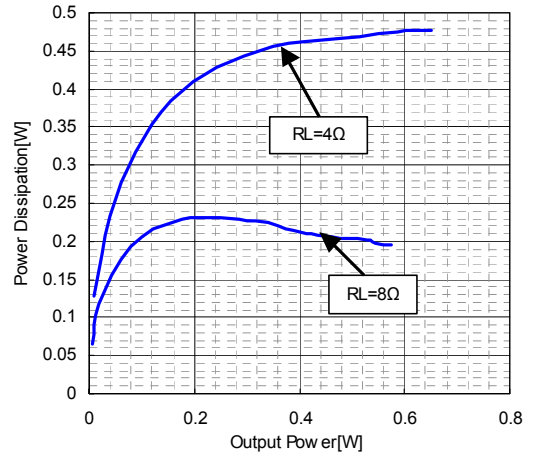

PSRR vs Frequency
V+=3V, RL=4Ω, Ta=25°C, RIN=GND

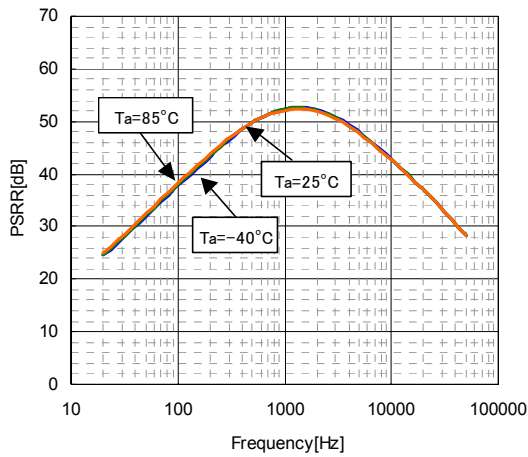

PSRR vs Frequency
V+=5V, RL=8Ω, Ta=25°C, RIN=GND

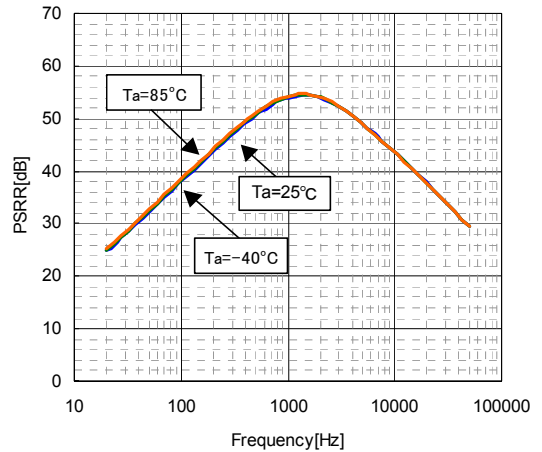

TYPICAL CHARACTERISTICS

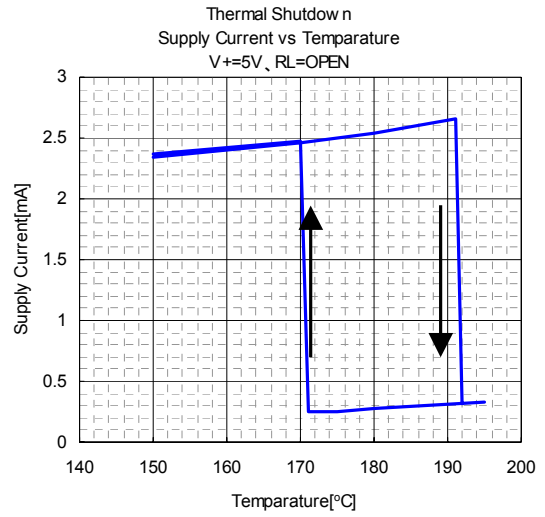
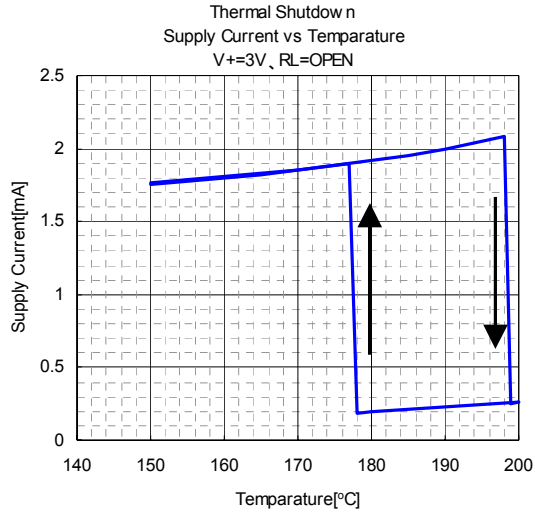

PACKAGE DIMENSIONS

VSP8

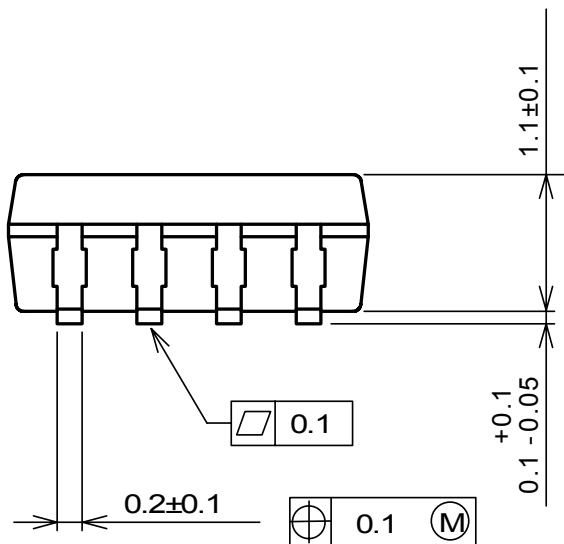
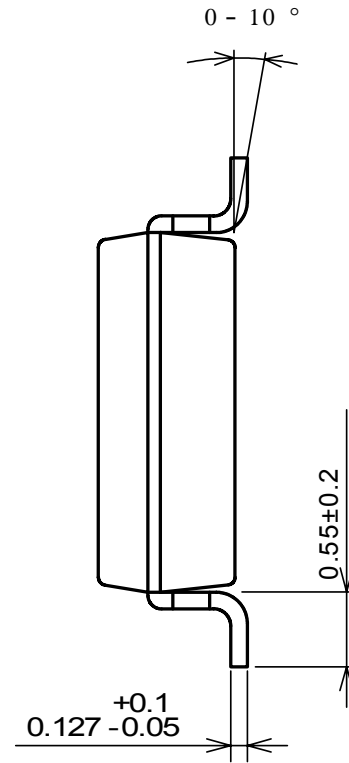
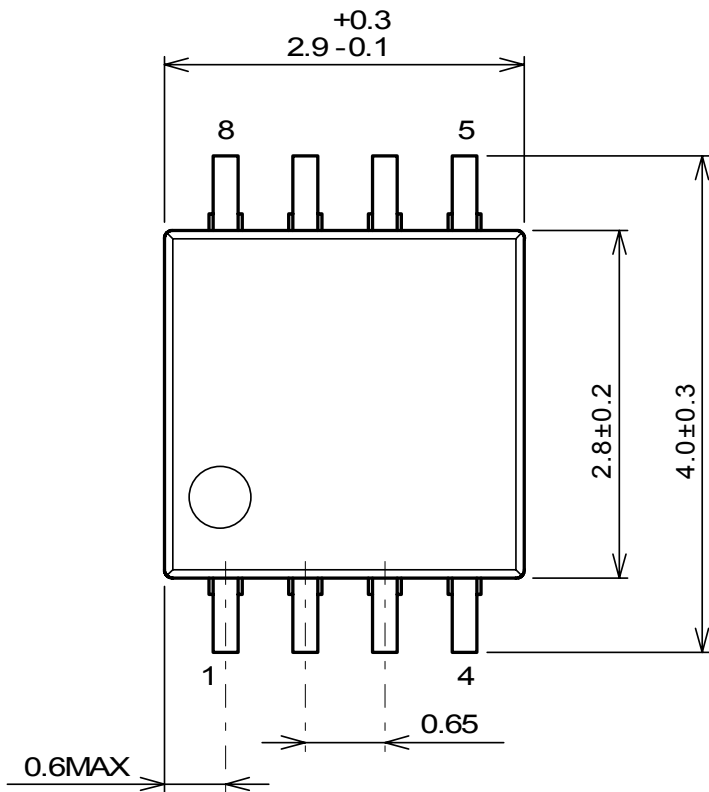

Unit:mm

NJU7084

www.DataSheet4U.com

PACKAGE DIMENSIONS

DMP24

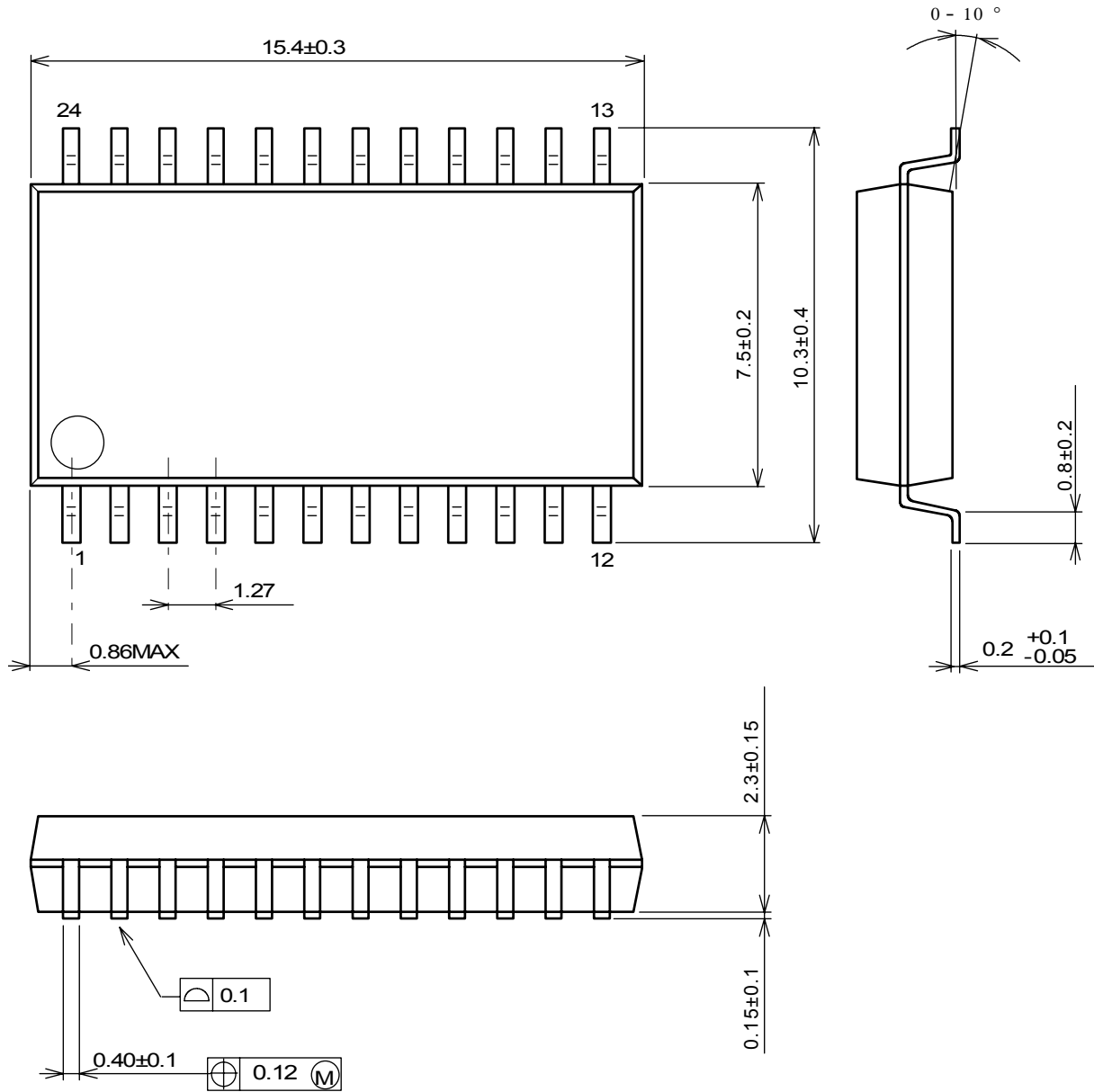

Unit:mm

[CAUTION]

The specifications on this databook are only given for information, without any guarantee as regards either mistakes or omissions. The application circuits in this databook are described only to show representative usages of the product and not intended for the guarantee or permission of any right including the industrial rights.