

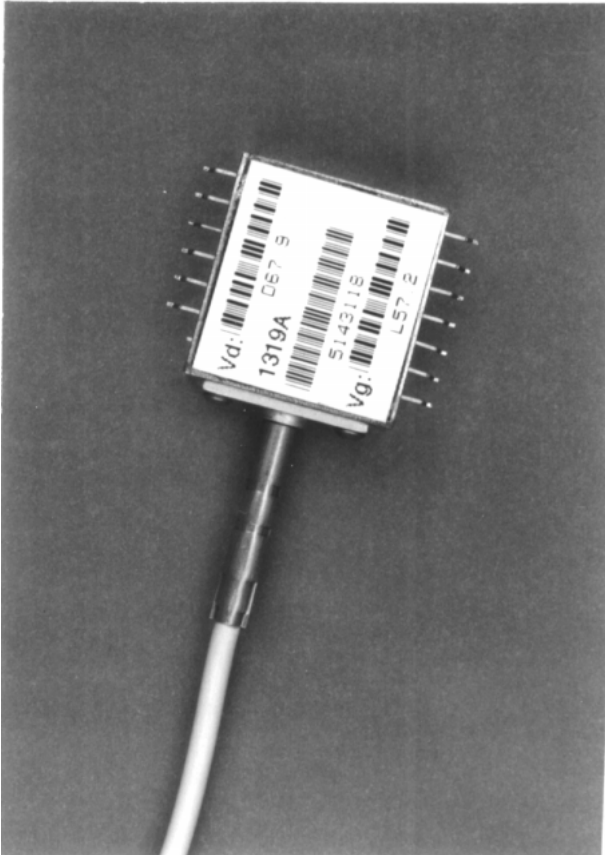

1319-Type High-Speed Lightwave Receiver



The 1319-Type Lightwave Receiver is available in a compact, butterfly package.

Features

- High data rate capability: 2.5 Gbits/s
- APD or PIN photodetector
- Fully operational through the 1.3 μm to 1.55 μm wavelength range
- Typical sensitivity:
 - -34 dBm with APD
 - -25 dBm with pin
- >25 dB typical dynamic range
- Single-mode fiber pigtail with FC/PC or SC optical connector
- High-performance GaAs preamplifier
- Operating case temperature range:
 - 0 °C to 65 °C with APD
 - -40 °C to +85 °C with PIN
- Compact, butterfly package
- Single-ended or differential outputs

Applications

- Line terminal equipment
- High-speed networks up to 2.5 Gbits/s
- SONET OC-48 and SDH STM-16 telecommunications applications
- Extended reach datacomm and telecomm applications
- Digital video

Description

Receiver Operation

The 1319-Type high-speed fiber-optic receiver consists of a wideband linear preamp followed by a limiting amplifier buffer stage. It is designed for use in single-mode, high-speed applications at the SONET OC-48 and the ITU-T synchronous digital hierarchy (SDH) STM-16 data rate of 2488.32 Mbits/s. The receiver is available with either a PIN photodetector or an APD photodetector.

At 2.5 Gbits/s, the typical room temperature receiver sensitivity measured at 3×10^{-11} bit-error rate is -34 dBm for the APD receiver and -25 dBm for the PIN version of the receiver. The operating case temperature range for the APD receiver is 0 °C to 60 °C and -40 °C to $+85$ °C for the PIN receiver.

The receiver is manufactured in a compact, 14-pin butterfly lead package with a single-mode optical fiber pigtail. The fiber in the 1319M-Type is internally beveled for low optical return loss. The receivers are available with the fiber pigtail terminated in FC-PC or SC optical connectors.

The incoming light pulses are converted to electrical current pulses by a high-performance APD or PIN photodiode. The photodiode is coupled to a GaAs IC preamplifier having differential data outputs. These differential outputs are ac-coupled through 0.047 μ F capacitors to the package data output pins (see Figure 2).

Power Supplies

Both versions of the receiver require a single -5.2 V power supply for the preamplifier IC. To obtain the highest overload capability, the PIN in the 1319P series should be biased at 5 V. However, if a lower overload response can be tolerated, then the PIN bias lead may be connected to circuit ground. Biasing the PIN at 0 V will reduce the maximum overload capability by approximately 4 dB.

For the 1319M codes, the APD requires a positive high voltage (~ 60 V) bias supply. The nominal 25 °C gain = 12 and gain = 4 bias voltages are supplied with each receiver. In order to maintain constant APD gain over the full operating temperature range, the high-voltage bias supply should have a means to automatically adjust the voltage output to match the $0.18\%/^{\circ}\text{C}$ gain versus temperature coefficient of the APD. The 1319M has an internal thermistor, with a nominal 25 °C resistance of 3 k Ω , which can be used to monitor the receiver operating temperature.

The 700B power module available from the Lucent Technologies Microelectronics Group Power Systems unit is a dc-dc converter that converts $+5$ Vdc to an adjustable high voltage output in the range required for the APD bias. The 700B uses the thermistor in the 1319M to provide a temperature-compensated output. Contact your local Lucent Sales Office for pricing and availability.

Single-Ended or Differential Data Outputs

Single-ended data output versions of both the 1319M-Type APD receiver and the 1319P-Type PIN receiver are available for drop-in replacements in designs using the current 1319B, 1319C, or 1319H models. In these single-ended data output receivers, pin 11 (see Figure 1) will not be connected internally.

For new designs, Lucent has versions of both the APD receiver and the PIN receiver with differential data outputs.

Printed-Wiring Board Layout

In devices with differential data outputs, due to internal constraints, the path length to the DATA output is 25 ps longer than the DATA path length at 2.5 Gbits/s. Therefore, to ensure optimum performance, the DATA and DATA signal traces on the application circuit board should be adjusted accordingly.

Pin Information

Table 1. Pin Names

Pin	Name
1	Ground
2	Photodiode bias
3	Ground
4	VEE (-5.2 V)
5	Ground
6	Thermistor*
7	Ground
8	Ground
9	Ground
10	DATA
11	$\overline{\text{DATA}}^\dagger$
12	Ground
13	NC
14	NC
CASE	Ground

* The thermistor is not available in the PIN version of the receiver. In 1319P-Type receivers, this pin will be open circuit internally.

† This is an internal open circuit in single-ended output Receivers.

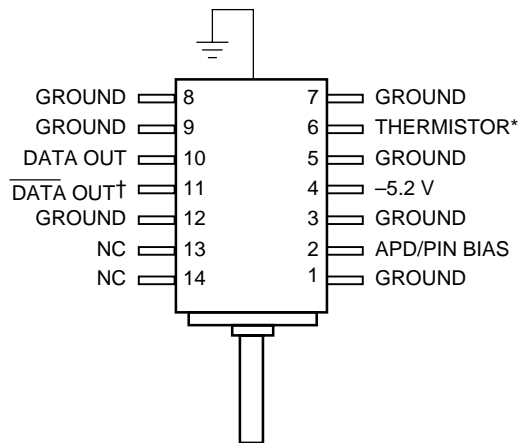

* No connection for PIN versions (not connected internally).

† No connection for single-ended versions.

1-635 (C).a

Figure 1. Pin Diagram

Handling Precautions

Mounting and Connections

The pigtail consists of a 41 in. \pm 13 in. (1041 mm \pm 330 mm), 8 μ m core, single-mode fiber. The receive pigtails have a 1600 μ m OD jacket diameter. Both models of the receiver are available with FC/PC or SC optical connectors. Other connector options may be available. Contact your Lucent Sales Office for availability and ordering information.

The fiber bending radius during operation and storage is 1.5 in. (38 mm) minimum.

Electrostatic Discharge

CAUTION: This device is susceptible to damage as a result of electrostatic discharge (ESD). Take proper precautions during both handling and testing. Follow guidelines such as JEDEC Publication No. 108-A.

Although protection circuitry is designed into the device, take proper precautions to avoid exposure to ESD.

Lucent employs a human-body model (HBM) for ESD-susceptibility testing and protection design evaluation. ESD voltage thresholds are dependent on the critical parameters used to define the model. A standard HBM (resistance = 1.5 k Ω , capacitance = 100 pF) is widely used and, therefore, can be used for comparison purposes.

The HBM ESD withstand voltage established for the 1319-Type receiver is \pm 500 V.

Absolute Maximum Ratings

Stresses in excess of the absolute maximum ratings can cause permanent damage to the device. These are absolute stress ratings only. Functional operation of the device is not implied at these or any other conditions in excess of those given in the operations section of the data sheet. Exposure to absolute maximum ratings for extended periods can adversely affect device reliability.

Parameter	Symbol	Min	Max	Unit
Negative Supply Voltage	V _{EE}	0	-6.0	V
Optical Input Power*:				
APD	P _{IN}	—	3	dBm
PIN	P _{IN}	—	8	dBm
Operating Case Temperature:				
APD	T _C	0	65	°C
PIN	T _C	-40	85	°C
Storage Temperature	T _{STG}	-40	85	°C
Lead Soldering Temperature	—	—	250	°C
Lead Soldering Time	—	—	10	seconds

* Under biased conditions. Unbiased, the maximum input optical power for both devices is 8 dBm.

Qualification Tests

The 1319-Type receiver has successfully passed the following qualification tests and meets the intent of Bellcore TR-NWT-000468.

Test	Conditions	Sample Size	Failure Criteria
Physical Dimensions	MIL-STD-883C-2016	90	Visual
External Visual	MIL-STD-883C-2009.8	90	Visual
Impact Shock	1500G, 5 hits, 6 axis, MIL-STD-883C-2002.3	11	Electrical/Optical
Variable Frequency Vibration	20G, 10 Hz to 2 kHz, 4 cycles, 3 directions, 4 min./cycle, MIL-STD-883C-2007.1	11	Electrical/Optical
Solderability	MIL-STD-883C-2003.5	100%	Visual
Temperature Cycle	-10 °C to +60 °C, 2000 cycles, MIL-STD-883C-1010.7	15	Electrical/Optical
High Temperature, High Humidity with Bias	60 °C, 95% relative humidity, rated bias, 4000 hours	4	Electrical/Optical
High Temperature with Bias	60 °C ambient, rated bias, 4000 hours, MIL-STD-883C-1005.5	—	Electrical/Optical
Electrostatic Discharge	Human-body model (to determine class)	3	Electrical/Optical
Power Cycling	1500 cycles (30 min. on/off) MIL-STD-1006	3	Electrical/Optical

Electrical/Optical Characteristics

Minimum and maximum values specified over operating case temperature and end of life (EOL). Typical values are for 25 °C beginning of life (BOL).

Table 2. Electrical Characteristics

Parameter	Symbol	Min	Typ	Max	Unit
dc Power Supply Voltages:					
Negative Supply	V _{EE}	-5.46	-5.2	-4.94	V
APD Bias Supply (1319M-Types)*	V _{APD}	35	—	85	V
PIN Bias Supply (1319P-Types)†	V _{PIN}	0	5.0	10.0	V
dc Power Supply Currents:					
Negative Supply	I _{EE}	—	120	160	mA
APD Bias (G = 12)	I _{APD}	—	—	4	mA
PIN Bias	I _{PIN}	—	—	4	mA
Power Dissipation	P _D	—	0.6	—	W
Small Signal (<10 µA) Transimpedance‡	T _Z	5 k	10 k	—	Ω
Large Signal (>100 µA) Transimpedance‡	T _Z	—	0.5 k	0.7 k	Ω
Input Noise Current (100 kHz—2.5 GHz)	—	—	250	300	nARMS
Output Return Loss	—	10	15	—	dB

* The gain = 12 APD voltage at 25 °C is supplied with each device. For optimum performance, V_{APD} must be set within 50 mV of the specified value. V_{APD} needs to be temperature compensated to maintain constant gain over operating temperature. The nominal compensation is 0.18%/°C.

† To obtain maximum overload input power, V_{PIN} must be set to 5 V. If a lower overload input power can be tolerated (≈ 4 dB lower), V_{PIN} can be set to 0 V (grounded).

‡ Transimpedance, $T_Z = \frac{V_{p-p}}{I_{PH(Avg)}}$, where I_{PH(Avg)} is the average photodiode current.

Table 3. Optical Characteristics

Parameter	Symbol	Min	Typ	Max	Unit
Optical Wavelength for Rated Sensitivity	λ	1.25	—	1.6	µm
Sensitivity (2.5 Gbits/s, 2 ²³ - 1 PRBS, 3 x 10 ⁻¹¹ BER):					
APD Version (APD Gain = 12)	P _{LOW}	—	-34	-32	dBm
PIN Version	P _{LOW}	—	-24	-22	dBm
Maximum Optical Input Power (2.5 Gbits/s, 2 ²³ - 1 PRBS, 3 x 10 ⁻¹¹ BER):					
APD Version (APD Gain = 3)	P _{HIGH}	-3	—	—	dBm
PIN Version	P _{HIGH}	1	—	—	dBm
High-frequency Cutoff at -3 dB from Midband Response	f _c	1.4	1.7	2.3	GHz
Maximum Reflectance	—	—	—	-27	dBm

Electrical/Optical Characteristics (continued)

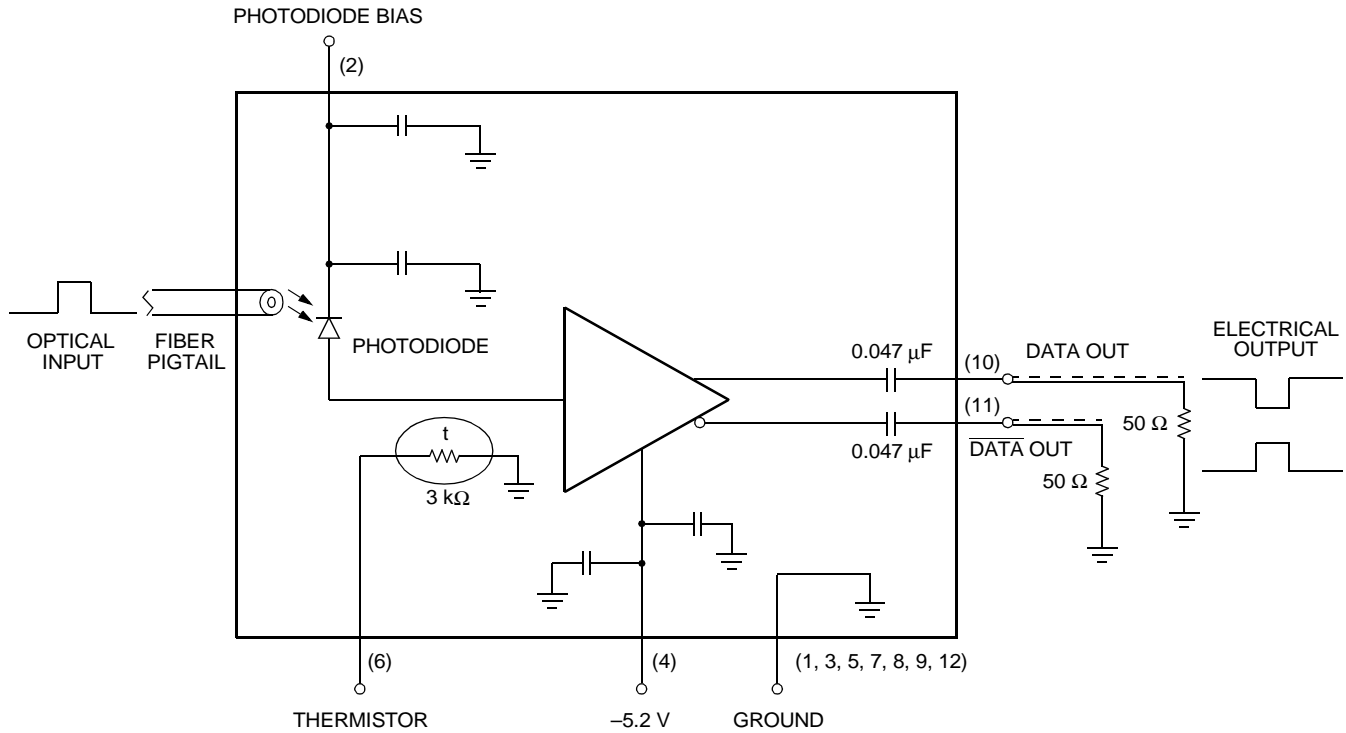

* The thermistor is not present on PIN version.

1-871 (C).a

Figure 2. 1319-Type High-Speed Lightwave Receiver Schematic

Recommended Circuit Diagram

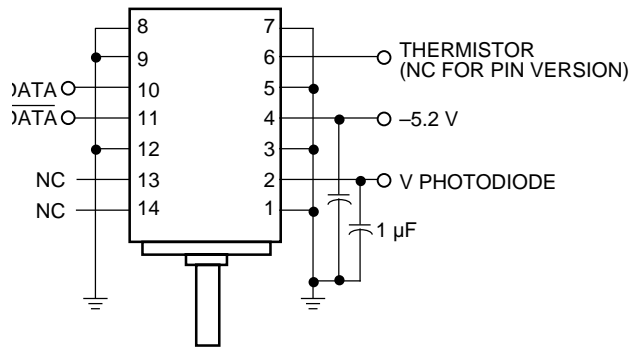

* Pin 11 is a NC for single-ended output versions.

1-636 (C).a

Outline Diagram

Dimensions are in inches and (millimeters).

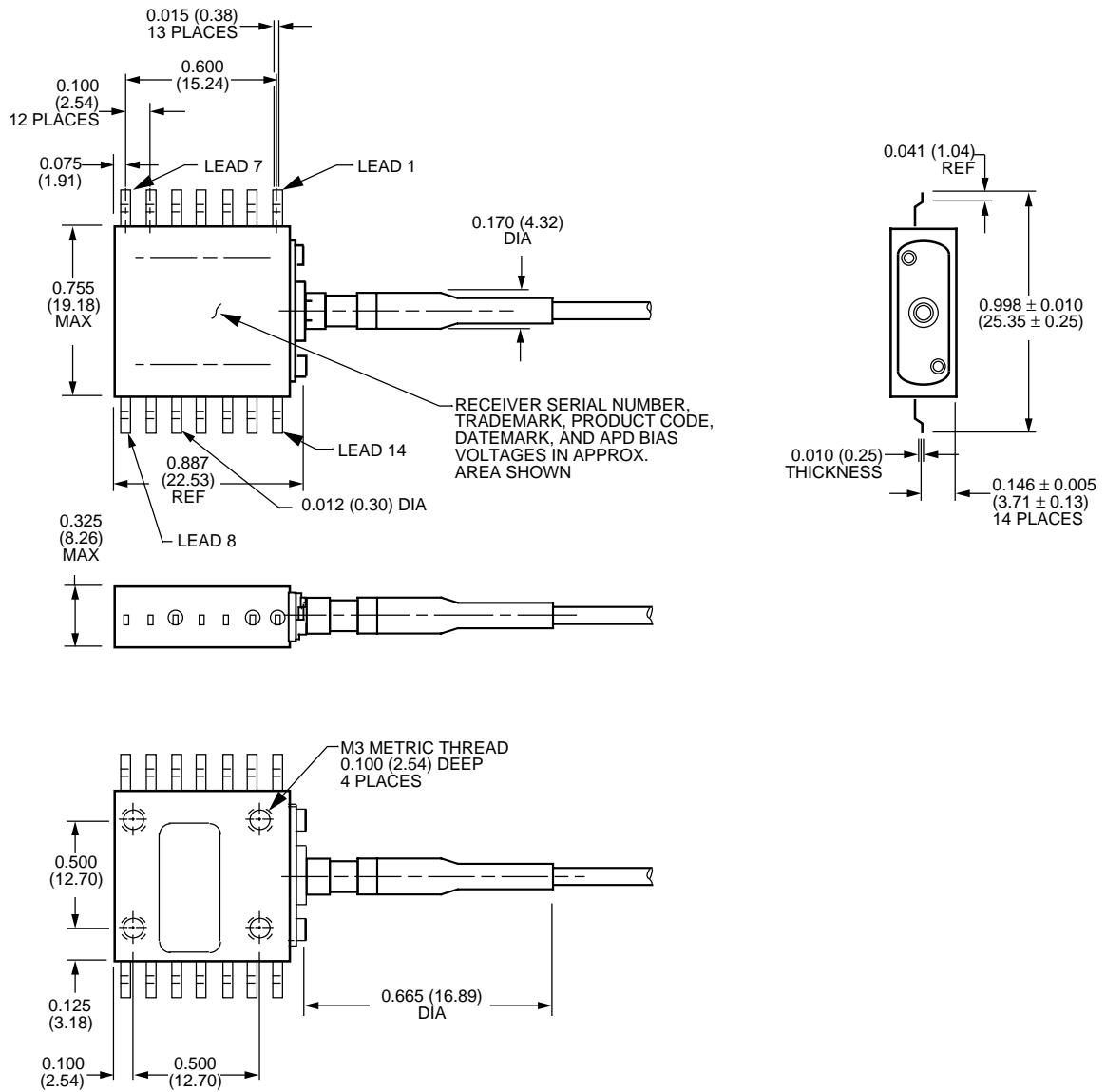

1-637 (C).a

Ordering Information

Receiver	Output	Photodiode	Optical Connector	Comcode
1319PA	Differential	PIN	FC/PC	107841603
1319PC	Differential	PIN	SC	107841595
1319PR	Single-ended	PIN	FC/PC	107953572
1319PS	Single-ended	PIN	SC	107861270
1319MA	Differential	APD	FC/PC	107913485
1319MC	Differential	APD	SC	107913501
1319MR	Single-ended	APD	FC/PC	107953564
1319MS	Single-ended	APD	SC	107914061

Related Product Information

Product Code	Description	Document Number
D2300-Type Laser 2000 Laser	Isolated DFB Laser Module for 1.3 μm Digital Applications	DS00-167LWP
D2500-Type Laser 2000 Laser	Isolated DFB Laser Module for 1.5 μm Digital Applications	DS00-166LWP
D2525P-Type Laser 2000 Laser	Isolated DFB Laser Module with PMF Fiber	DS00-073LWP
E2500-Type Laser 2000 Laser Module	2.5 Gbits/s Electroabsorption Modulated Laser Module for Ultra-Long-Reach Applications	DS98-368LWP
1724-Type (W Series)	Optical Amplifier Platform, 1724-Type Erbium-Doped Fiber Amplifier (W Series)	DS00-259OPTO
1724-Type (S and V Series)	Optical Amplifier Platform, 1724-Type Erbium-Doped Fiber Amplifier (S and V Series)	DS00-123OPTO
1730-Type (S Series)	1730-Type Erbium-Doped Fiber Amplifier	DS99-353LWP
1725-Type	Gain Block Erbium-Doped Fiber Amplifier	DS99-271LWP-1
1735-Type	Gain Block Erbium-Doped Fiber Amplifier	DS00-113OPTO
—	10 Gbits/s Lithium Niobate Electro-Optic Modulator	DS99-342LWP
—	40 Gbits/s Lithium Niobate Electro-Optic Modulator	DS99-365LWP
700B Power Module	Power Module (High Voltage Output dc-dc Converter)	DS95-182EPS
2.5 Gbits/s Receiver	Technical Note	TN95-013LWP

For additional information, contact your Microelectronics Group Account Manager or the following:

INTERNET: <http://www.lucent.com/micro>, or for Optoelectronics information, <http://www.lucent.com/micro/opto>

E-MAIL: docmaster@micro.lucent.com

N. AMERICA: Microelectronics Group, Lucent Technologies Inc., 555 Union Boulevard, Room 30L-15P-BA, Allentown, PA 18109-3286
1-800-372-2447, FAX 610-712-4106 (In CANADA: 1-800-553-2448, FAX 610-712-4106)

ASIA PACIFIC: Microelectronics Group, Lucent Technologies Singapore Pte. Ltd., 77 Science Park Drive, #03-18 Cintech III, Singapore 118256
Tel. (65) 778 8833, FAX (65) 777 7495

CHINA: Microelectronics Group, Lucent Technologies (China) Co., Ltd., A-F2, 23/F, Zao Fong Universe Building, 1800 Zhong Shan Xi Road, Shanghai 200233 P. R. China Tel. (86) 21 6440 0468, ext. 325, FAX (86) 21 6440 0652

JAPAN: Microelectronics Group, Lucent Technologies Japan Ltd., 7-18, Higashi-Gotanda 2-chome, Shinagawa-ku, Tokyo 141, Japan
Tel. (81) 3 5421 1600, FAX (81) 3 5421 1700

EUROPE: Data Requests: MICROELECTRONICS GROUP DATALINE: Tel. (44) 7000 582 368, FAX (44) 1189 328 148
Technical Inquiries: OPTOELECTRONICS MARKETING: (44) 1344 865 900 (Ascot UK)

Lucent Technologies Inc. reserves the right to make changes to the product(s) or information contained herein without notice. No liability is assumed as a result of their use or application. No rights under any patent accompany the sale of any such product(s) or information.

