

BU-61582 SPACE LEVEL MIL-STD-1553 BC/RT/MT ADVANCED COMMUNICATION ENGINE (SP'ACE) TERMINAL

Make sure the next
Card you purchase
has...

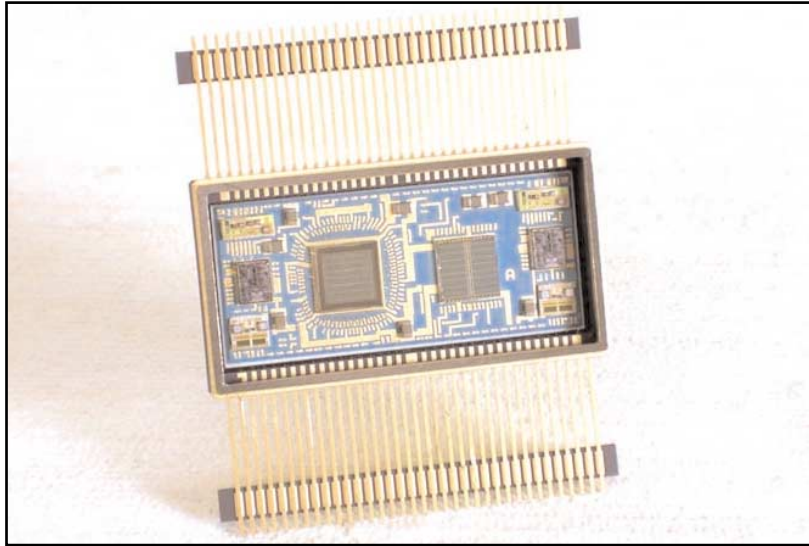

DESCRIPTION

DDC's BU-61582 Space Advanced Communication Engine (SP'ACE) is a radiation hardened version of the BU-61580 ACE terminal. DDC is able to supply the BU-61582 with enhanced screening for space and other high reliability applications.

The BU-61582 provides a complete integrated BC/RT/MT interface between a host processor and a MIL-STD-1553 bus. The BU-61582 provides functional and software compatibility with the standard BU-61580 product and is packaged in the same 1.9 square-inch package footprint.

As an option, DDC can supply the BU-61582 with space level screening. This entails enhancements in the areas of element evaluation and screening procedures for active and passive elements, as well as the manufacturing and screening processes used in producing the terminals.

The BU-61582 integrates dual transceiver, protocol, memory management and processor interface logic, and 16K words of RAM in the choice of 70-pin DIP or flat pack packages. Transceiverless versions may be used with an external electrical or fiber optic transceiver.

To minimize board space and 'glue' logic, the SP'ACE terminals provide ultimate flexibility in interfacing to a host processor and internal/external RAM.

FEATURES

- Radiation-Hardened to 1 MRad
- Fully Integrated 1553 Terminal
- Flexible Processor Interface
- 16K x 16 Internal RAM
- Automatic BC Retries
- Programmable BC Gap Times
- BC Frame Auto-Repeat
- Intelligent RT Data Buffering
- Small Ceramic Package
- Available to SMD 5962-96887
- Multiple Ordering Options;
 - +5V (Only)
 - +5V/-15V
 - +5V/-12V
 - +5V/Transceiverless
 - +5V (Only, with Transmit Inhibits)



Data Device Corporation
105 Wilbur Place
Bohemia, New York 11716
631-567-5600 Fax: 631-567-7358
www.ddc-web.com

FOR MORE INFORMATION CONTACT:

Technical Support:
1-800-DDC-5757 ext. 7234

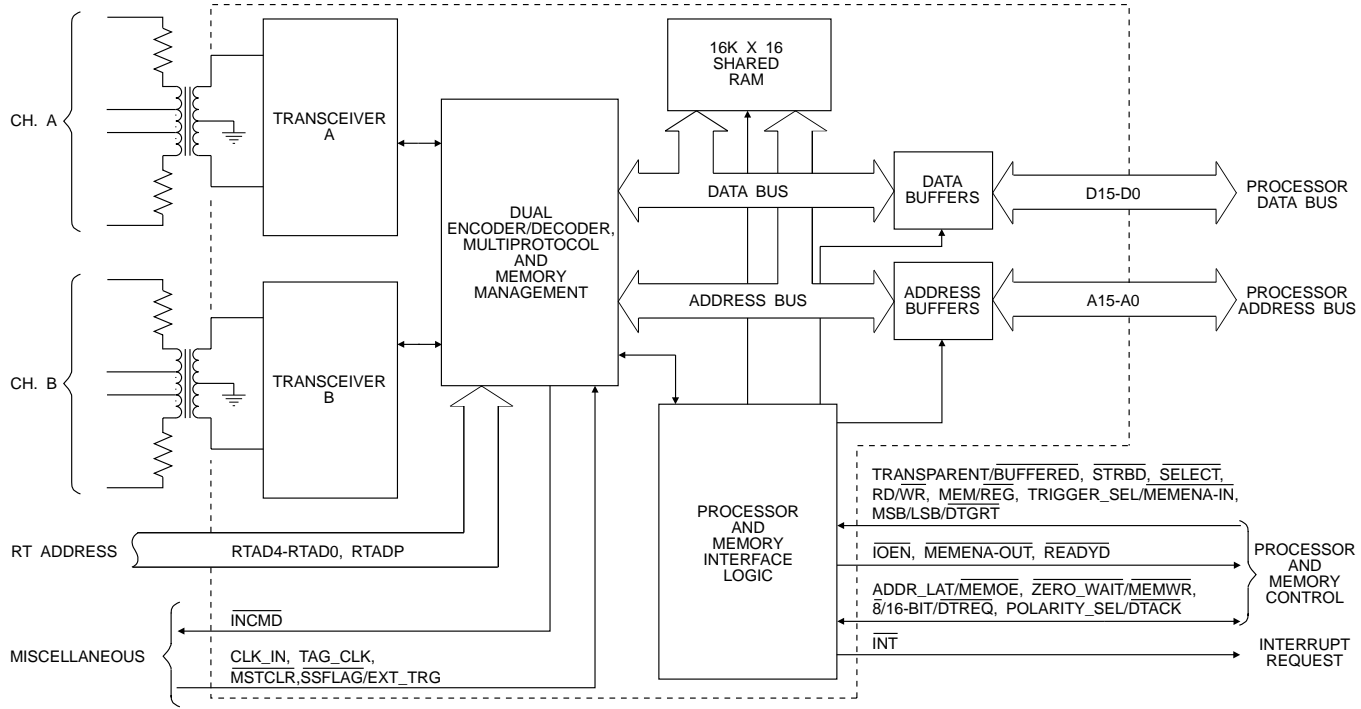

FIGURE 1. BU-61582 BLOCK DIAGRAM

TABLE 1. SP'ACE SERIES SPECIFICATIONS				
PARAMETER	MIN	TYP	MAX	UNITS
ABSOLUTE MAXIMUM RATING				
Supply Voltage				
■ Logic +5V	-0.5		7.0	V
■ Transceiver +5V	-0.5		7.0	V
■ -15V	+0.5		-18.0	V
■ -12V	+0.5		-18.0	V
Logic				
■ Voltage Input Range	-0.5		$V_{CC}+0.5$	V
RECEIVER				
Differential Input Resistance (Notes 1-6)	11			k Ω
Differential Input Capacitance (Notes 1-6)			10	pF
Threshold Voltage, Transformer Coupled, Measured on Stub			0.860	Vp-p
Common Mode Voltage (Note 7)			10	Vpeak
TRANSMITTER				
Differential Output Voltage				
■ Direct Coupled Across 35 Ω , Measured on Bus	6	7	9	Vp-p
■ Transformer Coupled Across 70 Ω , Measured on Bus	18	20	27	Vp-p
Output Noise, Differential (Direct Coupled)			10	mVp-p, diff
Output Offset Voltage, Transformer Coupled Across 70 ohms	-250		250	mV
Rise/Fall Time	100	150	300	nsec
LOGIC				
V_{IH}	3.9			V
V_{IL}			1.3	V
I_{IH} ($V_{CC}=5.5V, V_{IN}=5.5V$)	-10		10	μA
I_{IH} ($V_{CC}=5.5V, V_{IN}=0V$)				
■ DB15-DB0, A15-A0	-550		-60	μA
RTAD4-RTAD0, RTADP, MEMWR/ZEROWAIT, DTREQ/16/8, DTACK/POLARITY_SEL				
■ All Other Inputs	-10		+10	μA
V_{OH} ($V_{CC}=4.5V, V_{IH}=4.2V, V_{IL}=1.0V, I_{OH}=\max$)	4.0			V
V_{OL} ($V_{CC}=4.5V, V_{IH}=2.7V, V_{IL}=0.2V, I_{OL}=\max$)			0.5	V
I_{OL}	8.0			mA
I_{OH}			-8.0	mA
POWER SUPPLY REQUIREMENTS				
Voltages/Tolerances				
■ BU-61582X0				
• +5V (Logic)	4.5	5.0	5.5	V
■ BU-61582X1				
• +5V (Logic)	4.5	5.0	5.5	V
• +5V (Ch. A, Ch. B)	4.5	5.0	5.5	V
• V_A, V_B	-14.25	-15.0	-15.75	V
■ BU-61582X2				
• +5V (Logic)	4.5	5.0	5.5	V
• +5V (Ch. A, Ch. B)	4.5	5.0	5.5	V
• V_A, V_B	-11.4	-12.0	-12.6	V
■ BU-61582X3/X6 (+5V Only)				
• +5V (Logic)	4.75	5.0	5.25	V
• +5V (Ch. A, Ch. B)	4.75	5.0	5.25	V

TABLE 1. SP'ACE SERIES SPECIFICATIONS (CONT)				
PARAMETER	MIN	TYP	MAX	UNITS
POWER SUPPLY REQUIREMENTS (Cont'd)				
Current Drain (Total Hybrid)				
■ BU-61582X0				
• +5V (Logic)		50	150	mA
■ BU-61582X1				
• +5V (Note 10)		140	240	mA
• -15V				
• Idle		30	60	mA
• 25% Transmitter Duty Cycle		68	108	mA
• 50% Transmitter Duty Cycle		105	160	mA
• 100% Transmitter Duty Cycle		180	255	mA
■ BU-61582X2				
• +5V (Note 10)		140	240	mA
• -12V				
• Idle		30	60	mA
• 25% Transmitter Duty Cycle		80	120	mA
• 50% Transmitter Duty Cycle		130	185	mA
• 100% Transmitter Duty Cycle		230	305	mA
■ BU-61582X3/X6 (+5V) (Logic, CH. A & CH. B)				
• Idle			250	mA
• 25% Transmitter Duty Cycle			335	mA
• 50% Transmitter Duty Cycle			460	mA
• 100% Transmitter Duty Cycle			670	mA
POWER DISSIPATION				
Total Hybrid				
■ BU-61582X0		0.250	0.750	W
■ BU-61582X1				
• Idle		0.875	2.1	W
• 25% Transmitter Duty Cycle		1.22	2.5	W
• 50% Transmitter Duty Cycle		1.475	2.97	W
• 100% Transmitter Duty Cycle		2.0	3.77	W
■ BU-61582X2				
• Idle		0.86	1.92	W
• 25% Transmitter Duty Cycle		1.16	2.35	W
• 50% Transmitter Duty Cycle		1.46	2.84	W
• 100% Transmitter Duty Cycle		2.06	3.71	W
■ BU-61582X3/X6				
• Idle			1.34	W
• 25% Transmitter Duty Cycle			1.57	W
• 50% Transmitter Duty Cycle			1.79	W
• 100% Transmitter Duty Cycle			2.23	W
Hottest Die				
■ BU-61582X0		0.225	0.50	W
■ BU-61582X1				
• Idle		0.335	0.68	W
• 25% Transmitter Duty Cycle		0.600	1.06	W
• 50% Transmitter Duty Cycle		0.860	1.45	W
• 100% Transmitter Duty Cycle		1.385	2.23	W
■ BU-61582X2				
• Idle		0.290	0.59	W
• 25% Transmitter Duty Cycle		0.590	0.92	W
• 50% Transmitter Duty Cycle		0.890	1.36	W
• 100% Transmitter Duty Cycle		1.490	2.16	W
■ BU-61582X3/X6				
• Idle			0.28	W
• 25% Transmitter Duty Cycle			0.51	W
• 50% Transmitter Duty Cycle			0.75	W
• 100% Transmitter Duty Cycle			1.22	W

TABLE 1. SP'ACE SERIES SPECIFICATIONS (CONT)

PARAMETER	MIN	TYP	MAX	UNITS
CLOCK INPUT				
Frequency				
<ul style="list-style-type: none"> ■ Nominal Value (programmable) <ul style="list-style-type: none"> • Default Mode • Option ■ Long Term Tolerance <ul style="list-style-type: none"> • 1553A Compliance • 1553B Compliance ■ Short Term Tolerance, 1 second <ul style="list-style-type: none"> • 1553A Compliance • 1553B Compliance ■ Duty Cycle <ul style="list-style-type: none"> • 16 MHz • 12 MHz 		16.0 12.0		MHz MHz
			0.01 0.1	% %
			0.001 0.01	% %
	33 40		67 60	% %
1553 MESSAGE TIMING				
Completion of CPU Write (BC Start-to-Start of Next Message)		2.5		μs
BC Intermessage Gap (Note 8)		10.5		μs
BC/RT/MT Response Timeout (Note 9)				
<ul style="list-style-type: none"> ■ 18.5 nominal ■ 22.5 nominal ■ 50.5 nominal ■ 128.0 nominal 	17.5 21.5 49.5 128	18.5 22.5 50.5 129.5	19.5 23.5 51.5 131	μs μs μs μs
Transmitter Watchdog Timeout			668	μs
RT Response Timeout (Note 11)	4	6.5	9	μs
THERMAL				
Thermal Resistance, Junction-to-Case, Hottest Die (θJC)				
<ul style="list-style-type: none"> ■ BU-61582X0 ■ BU-61582X1 ■ BU-61582X2 ■ BU-61582X3/X6 		4.6 7.2 7.2 12		°C/W °C/W °C/W °C/W
Operating Junction Temperature	-55		150	°C
Storage Temperature	-65		150	°C
Lead Temperature (soldering, 10 sec.)			+300	°C
PHYSICAL CHARACTERISTICS				
Size				
<ul style="list-style-type: none"> ■ 70-pin DIP, Flat Pack ■ J-Lead, Gull Leads 		1.9 X 1.0 X 0.215 (48.26 x 25.4 x 5.46)		in. (mm)
Weight				
<ul style="list-style-type: none"> ■ 70-pin DIP, Flat Pack ■ J-Lead, Gull Leads 		0.6 (7)		oz (g)

TABLE 1 NOTES: Notes 1 through 6 are applicable to the Receiver

Differential Resistance and Differential Capacitance specifications:

- (1) Specifications include both transmitter and receiver (tied together internally).
- (2) Measurement of impedance is directly between pins TX/RX A(B) and TX/RX A(B) of the SP'ACE Series hybrid.
- (3) Assuming the connection of all power and ground inputs to the hybrid.
- (4) The specifications are applicable for both unpowered and powered conditions.
- (5) The specifications assume a 2 volt rms balanced, differential, sinusoidal input. The applicable frequency range is 75 kHz to 1 MHz.
- (6) Minimum resistance and maximum capacitance parameters are guaranteed, but not tested, over the operating range.
- (7) Assumes a common mode voltage within the frequency range of dc to 2 MHz, applied to pins of the isolation transformer on the stub side (either direct or transformer coupled), referenced to hybrid ground. Use a DDC recommended transformer or other transformer that provides an equivalent minimum CMRR.
- (8) Typical value for minimum intermessage gap time. Under software control, may be lengthened to (65,535 μs minus message time), in increments of 1 μs.

TABLE 1 NOTES (cont)

(9) Software programmable (4 options). Includes RT-to-RT Timeout (Mid-Parity of Transmit Command to Mid-Sync of Transmitting RT Status).

(10) For both +5 V logic and transceiver. +5 V for channels A and B.

(11) Measured from mid-parity crossing of Command Word to mid-sync crossing of RT's Status Word.

INTRODUCTION

DDC's SP'ACE series of Integrated BC/RT/MT hybrids provide a complete, flexible interface between a microprocessor and a MIL-STD-1553A, B Notice 2, McAir, or STANAG 3838 bus, implementing Bus Controller, Remote Terminal (RT) and Monitor Terminal (MT) modes. Packaged in a single 1.9 square inch 70-pin DIP, surface mountable Flat Pack or Gull Lead, the SP'ACE series contains dual low-power transceivers and encoder/decoders, complete BC/RT/MT multiprotocol logic, memory management and interrupt logic, 16K X 16 of shared static RAM and a direct, buffered interface to a host processor bus.

The BU-61582 contains internal address latches and bidirectional data buffers to provide a direct interface to a host processor bus. The BU-61582 may be interfaced directly to both 16-bit and 8-bit microprocessors in a buffered shared RAM configuration. In addition, the SP'ACE may connect to a 16-bit processor bus via a Direct Memory Access (DMA) interface. The BU-61582 includes 16K words of buffered RAM. Alternatively, the SP'ACE may be interfaced to as much as 64k words of external RAM in either the shared RAM or DMA configurations.

The SP'ACE RT mode is multiprotocol, supporting MIL-STD-1553A, MIL-STD-1553B Notice 2, and STANAG 3838 (including EFABus).

The memory management scheme for RT mode provides an option for separation of broadcast data, in compliance with 1553B Notice 2. Both double buffer and circular buffer options are programmable by subaddress. These features serve to ensure data consistency and to off-load the host processor for bulk data transfer applications.

The SP'ACE series implements three monitor modes: a word monitor, a selective message monitor, and a combined RT/selective monitor.

Other features include options for automatic retries and programmable intermessage gap for BC mode, an internal Time Tag Register, an Interrupt Status Register and internal command illegalization for RT mode.

FUNCTIONAL OVERVIEW

TRANSCEIVERS

For the +5 V and -15 V/-12 V front end, the BU-61582X1(X2) uses low-power bipolar analog monolithic and thin-film hybrid technology. The transceiver requires +5 V and -15 V (-12 V) only (requiring no +15 V/+12 V) and includes voltage source transmitters. The voltage source transmitters provide superior line driving capability for long cables and heavy amounts of bus loading.

The receiver sections of the BU-61582 are fully compliant with MIL-STD-1553B in terms of front end overvoltage protection, threshold, common mode rejection, and word error rate. In addition, the receiver filters have been designed for optimal operation with the J-Rad chip's Manchester II decoders.

J-RAD DIGITAL MONOLITHIC

The J-Rad digital monolithic represents the cornerstone element of the BU-61582 SP'ACE family of terminals. The J-Rad chip is actually a radiation hardened version of DDC's J' (J-prime) monolithic which is the key building block behind DDC's non-radiation hardened BU-61580 ACE series of terminals. As such, the J-Rad possesses all the enhanced hardware and software features which have made the BU-61580 ACE the industry standard 1553 interface component.

The J-Rad chip consists of a dual encoder/decoder, complete protocol for Bus Controller (BC), 1553A/B/McAir Remote Terminal (RT), and Monitor (MT) modes; memory management and interrupt logic; a flexible, buffered interface to a host processor bus and optional external RAM; and a separate buffered interface to external RAM. Reference the region within the dotted line of FIGURE 1. Besides realizing all the protocol, memory management, and interface functions of the earlier AIM-HY series, the J-Rad chip includes a large number of enhancements to facilitate hardware and software design, and to further off-load the 1553 terminal's host processor.

DECODERS

The default mode of operation for the BU-61582 BC/RT/MT requires a 16 MHz clock input. If needed, a software programmable option allows the device to be operated from a 12 MHz clock input. Most current 1553 decoders sample using a 10 MHz or 12 MHz clock. In the 16 MHz mode (default following a hardware or software reset), the decoders sample 1553 serial data using the 16 MHz clock. In the 12 MHz mode (or 16 MHz), the decoders can be programmed to sample using both clock edges; this provides a sampling rate of 24 MHz. The faster sampling rate for the J-Rad's Manchester II decoders provides superior performance in terms of bit error rate and zero-crossing distortion tolerance.

For interfacing to fiber optic transceivers for MIL-STD-1773 applications, a transceiverless version of the SP'ACE can be used. These versions provide a register programmable option for a direct interface to the single-ended outputs of a fiber optic receiver. No external logic is needed.

TIME TAGGING

The SP'ACE includes an internal read/writable Time Tag Register. This register is a CPU read/writable 16-bit counter with a programmable resolution of either 2, 4, 8, 16, 32, or 64 μ s per LSB. Also, the Time Tag Register may be clocked from an external oscillator. Another option allows software controlled incrementing of the Time Tag Register. This supports self-test for the Time Tag Register. For each message processed, the value of the Time Tag register is loaded into the second location of the respective descriptor stack entry ("TIME TAG WORD") for both BC and RT modes.

Additional provided options will: clear the Time Tag Register following a Synchronize (without data) mode command or load the Time Tag Register following a Synchronize (with data) mode command; enable an interrupt request and a bit setting in the Interrupt Status Register when the Time Tag Register rolls over from FFFF to 0000. Assuming the Time Tag Register is not loaded or reset, this will occur at approximately 4 second time intervals, for 64 μ s/LSB resolution, down to 131 ms intervals, for 2 μ s/LSB resolution.

Another programmable option for RT mode is the automatic clearing of the Service Request Status Word bit following the BU-61582's response to a Transmit Vector Word mode command.

INTERRUPTS

The SP'ACE series components provide many programmable options for interrupt generation and handling. The interrupt output pin $\overline{\text{INT}}$ has three software programmable modes of operation: a pulse, a level output cleared under software control, or a level output automatically cleared following a read of the Interrupt Status Register. Individual interrupts are enabled by the Interrupt Mask Register. The host processor may easily determine the cause of the interrupt by using the Interrupt Status Register. The Interrupt Status Register provides the current state of the interrupt conditions. The Interrupt Status Register may be updated in two ways. In the standard interrupt handling mode, a particular bit in the Interrupt Status Register will be updated only if the condition exists and the corresponding bit in the Interrupt Mask Register is enabled. In the enhanced interrupt handling mode, a particular bit in the Interrupt Status Register will be updated if the condition exists regardless of the contents of the corresponding Interrupt Mask Register bit. In any case, the respective Interrupt Mask Register bit enables an interrupt for a particular condition.

RADIATION HARDNESS

The BU-61582 combines analog bipolar transceivers with logic and RAM fabricated by Honeywell Solid State Electronics Center's (SSEC) 0.8 micron Radiation Insensitive CMOS (RICMOS-4) process to provide radiation survivability.

To summarize, the BU-61582 has a total gamma dose immunity of 1 MRad and an LET threshold of 59 MeV/mg/cm², providing a soft error rate of 3.6 x 10⁻⁵ errors/device-day. Since the transceiver is bipolar and the digital logic and RAM is implemented in Honeywell's RICMOS process, the hybrids are inherently immune to latchup.

HIGH-REL SCREENING

DDC is committed to the design and manufacture of hybrids and transformers with enhanced processing and screening for spaceborne applications and other systems requiring the highest levels of reliability. These platforms include launch vehicles, satellites and the International Space Station.

DDC has tailored its design methodologies to optimize the fabrication of space level hybrids. The intent of the design guidelines is to minimize the number of die and wirebonds, minimize the number of substrate layers, and maximize the space between components. DDC's space grade products combine analog bipolar and rad hard CMOS technology to provide various levels of radiation tolerance.

The BU-61582 is packaged in a 70-pin ceramic package. In contrast to Kovar (metal) packages, the use of ceramic eliminates the hermeticity problems associated with the glass beads used in the metal packages. In addition, ceramic packages provide more rigid leads, better thermal properties, easier wirebonding, and lower weight.

The production of the space level hybrids can entail enhanced screening steps beyond DDC's standard flow. This includes Condition A visual inspection, SEM analysis, and element evaluation for all integrated circuit die. For the hybrids, additional screening includes Particle Impact Noise Detection (PIND), 320-hour burn-in, 100% non-destructive wirebond pull, X-ray analysis, as well as Destructive Physical Analysis (DPA) testing, extended temperature cycling for QCI testing, and a moisture content limit of 5000 PPM. TABLE 3 summarizes the procurement screening, element evaluation, and hybrid screening used in the production of the BU-61582.

PART NUMBER	TOTAL DOSE	SINGLE EVENT UPSET	SINGLE EVENT LATCHUP
BU-61582(3)X0, X1,X2	1 MRad	3.6 x 10 ⁻⁵ errors/device-day, (LET Threshold of 59 MeV/mg/cm ²)	Immune
BU-61582(3)X3, BU-61582(3)X6	175 KRad	3.6 x 10 ⁻⁵ errors/device-day, (LET Threshold of 59 MeV/mg/cm ²)	Immune

ELEMENT EVALUATION	METHOD
Visual Inspection: Integrated Circuits Transistors & Diodes Passive Components	MIL-STD-883, Method 2010 Condition A MIL-STD-750, Method 2072 and 2073 MIL-STD-883, Method 2032 Class S
SEM Analysis for Integrated Circuits	MIL-STD-883, Method 2018
Element Evaluation: Visual, Electrical, Wire Bondability, 24-Hour Stabilization Bake, 10 Temperature Cycles 5000 g's constant acceleration 240-Hour Powered Burn-In and 1000-Hour Life Test (Burn-In and 1000-Hour Life Test Are Only Required For Active Components.)	MIL-H-38534
ASSEMBLY & TEST	
Particle Impact Noise Detection (PIND)	MIL-STD-883, Method 2020 Condition A
320-Hour Burn-In	MIL-STD-883, Method 1015
100% Non-Destructive Wirebond Pull	MIL-STD-883, Method 2023
Radiographic (X-Ray) Analysis	MIL-STD-883, Method 2012
QCI TESTING	
Extended Temperature Cycling: 20 Cycles Including Radiographic (X-Ray) Testing	MIL-STD-883, Method 1010 Condition C and MIL-STD-883, Method 2012
Moisture Content Limit of 5000 PPM	MIL-STD-883, Method 1018

ADDRESSING, INTERNAL REGISTERS, AND MEMORY MANAGEMENT

The software interface of the BU-61582 to the host processor consists of 17 internal operational registers for normal operation, an additional 8 test registers, plus 64K X 16 of shared memory address space. The BU-61582's 16K X 16 of internal RAM resides in this address space. Reference TABLE 4.

Definition of the address mapping and accessibility for the SP'ACE's 17 nontest registers, and the test registers, is as follows:

Interrupt Mask Register:

Used to enable and disable interrupt requests for various conditions.

Configuration Registers #1 and #2:

Used to select the BU-61582's mode of operation, and for software control of RT Status Word bits, Active Memory Area, BC Stop-on-Error, RT Memory Management mode selection, and control of the Time Tag operation.

Start/Reset Register:

Used for "command" type functions, such as software reset, BC/MT Start, Interrupt Reset, Time Tag Reset, and Time Tag Register Test. The Start/Reset Register includes provisions for stopping the BC in its auto-repeat mode, either at the end of the current message or at the end of the current BC frame.

BC/RT Command Stack Pointer Register:

Allows the host CPU to determine the pointer location for the current or most recent message when the BU-61582 is in BC or RT modes.

BC Control Word/RT Subaddress Control Word Register:

In BC mode, allows host access to the current or most recent BC Control Word. The BC Control Word contains bits that select the active bus and message format, enable off-line self-test, masking of Status Word bits, enable retries and interrupts, and specify MIL-STD-1553A or -1553B error handling. In RT mode, this register allows host access to the current or most recent Subaddress Control Word. The Subaddress Control Word is used to select the memory management scheme and enable interrupts for the current message. The read/write accessibility can be used as an aid for testing the SP'ACE hybrid.

Time Tag Register:

Maintains the value of a real-time clock. The resolution of this register is programmable from among 2, 4, 8, 16, 32, and 64 μ s/LSB. The TAG_CLK input signal also may cause an external

TABLE 4. ADDRESS MAPPING

ADDRESS LINES						REGISTER DESCRIPTION/ACCESSIBILITY
HEX	A4	A3	A2	A1	A0	
00	0	0	0	0	0	Interrupt Mask Register (RD/WR)
01	0	0	0	0	1	Configuration Register #1 (RD/WR)
02	0	0	0	1	0	Configuration Register #2 (RD/WR)
03	0	0	0	1	1	Start/Reset Register (WR)
03	0	0	0	1	1	BC/RT Command Stack Pointer Register (RD)
04	0	0	1	0	0	BC Control Word/RT Subaddress Control Word Register (RD/WR)
05	0	0	1	0	1	Time Tag Register (RD/WR)
06	0	0	1	1	0	Interrupt Status Register (RD)
07	0	0	1	1	1	Configuration Register #3 (RD/WR)
08	0	1	0	0	0	Configuration Register #4 (RD/WR)
09	0	1	0	0	1	Configuration Register #5 (RD/WR)
0A	0	1	0	1	0	Data Stack Address Register (RD/WR)
0B	0	1	0	1	1	BC Frame Time Remaining Register (RD/WR)
0C	0	1	1	0	0	BC Time Remaining to Next Message Register (RD/WR)
0D	0	1	1	0	1	BC Frame Time/RT Last Command /MT Trigger Word Register (RD/WR)
0E	0	1	1	1	0	RT Status Word Register (RD)
0F	0	1	1	1	1	RT BIT Word Register (RD)
10	1	0	0	0	0	Test Mode Register 0
•						
•						
17	1	0	1	1	1	Test Mode Register 7
18	1	1	0	0	0	reserved
•						
•						
1F	1	1	1	1	1	reserved

oscillator to clock the Time Tag Register. Start-of-Message (SOM) and End-of-Message (EOM) sequences in BC, RT, and Message Monitor modes cause a write of the current value of the Time Tag Register to the stack area of RAM.

Interrupt Status Register:

Mirrors the Interrupt Mask Register and contains a Master Interrupt bit. It allows the host processor to determine the cause of an interrupt request by means of a single READ operation.

Configuration Registers #3, #4, and #5:

Used to enable many of the BU-61582's advanced features. These include all the enhanced mode features; that is, all the functionality beyond that of the previous generation product, the BUS-61559 Advanced Integrated Mux Hybrid with Enhanced RT Features (AIM-HY'er). For BC mode, the enhanced mode features include the expanded BC Control Word and BC Block Status Word, additional Stop-On-Error and Stop-On-Status Set functions, frame auto-repeat, programmable intermessage gap times, automatic retries, expanded Status Word Masking, and the capability to generate interrupts following the completion of any selected message. For RT mode, the enhanced mode features include the expanded RT Block Status Word, the combined RT/Selective Message Monitor mode, internal wrapping of the $\overline{\text{RTFAIL}}$ output signal (from the J-Rad chip) to the $\overline{\text{RTFLAG}}$ RT Status Word bit, the double buffering scheme for individual receive (broadcast) subaddresses, and the alternate (fully software programmable) RT Status Word. For MT mode, use of the enhanced mode enables use of the Selective Message Monitor, the combined RT/Selective Monitor modes, and the monitor triggering capability.

Data Stack Address Register:

Used to point to the current address location in shared RAM used for storing message words (second Command Words, Data Words, RT Status Words) in the Selective Word Monitor mode.

Frame Time Remaining Register:

Provides a read only indication of the time remaining in the current BC frame. The resolution of this register is 100, 128 or 255 $\mu\text{s}/\text{LSB}$.

Message Time Remaining Register:

Provides a read only indication of the time remaining before the start of the next message in a BC frame. The resolution of this register is 1 $\mu\text{s}/\text{LSB}$.

BC Frame/RT Last Command/MT Trigger Word Register:

In BC mode, it programs the BC frame time, for use in the frame auto-repeat mode. The resolution of this register is 100 $\mu\text{s}/\text{LSB}$,

**TABLE 5. INTERRUPT MASK REGISTER
(READ/WRITE 00H)**

BIT	DESCRIPTION
15(MSB)	RESERVED
14	RAM PARITY ERROR
13	BC/RT TRANSMITTER TIMEOUT
12	BC/RT COMMAND STACK ROLLOVER
11	MT COMMAND STACK ROLLOVER
10	MT DATA STACK ROLLOVER
9	HS FAIL
8	BC RETRY
7	RT ADDRESS PARITY ERROR
6	TIME TAG ROLLOVER
5	RT CIRCULAR BUFFER ROLLOVER
4	BC/RT SELECTED MESSAGE
3	BC END OF FRAME
2	FORMAT ERROR
1	BC STATUS SET/RT MODE CODE/MT PATTERN TRIGGER
0(LSB)	END OF MESSAGE

with a range of 6.55 seconds; in RT mode, this register stores the current (or most previous) 1553 Command Word processed by the SP'ACE RT; in the Word Monitor mode, this register specifies a 16-bit Trigger (Command) Word. The Trigger Word may be used to start or stop the monitor, or to generate interrupts.

Status Word Register and BIT Word Registers:

Provide read-only indications of the BU-61582's RT Status and BIT Words.

Test Mode Registers 0-7:

These registers may be used to facilitate production or maintenance testing of the SP'ACE and systems incorporating the SP'ACE hybrid.

TABLE 6. CONFIGURATION REGISTER #1 (READ/WRITE 01H)

BIT	BC FUNCTION (BITS 11-0 ENHANCED MODE ONLY)	RT WITHOUT ALTERNATE STATUS	RT WITH ALTERNATE STATUS	MONITOR FUNCTION
15 (MSB)	RT/ \overline{BC} - \overline{MT} (logic 0)	(logic 1)	(logic 1)	(logic 0)
14	MT/ \overline{BC} -RT (logic 0)	(logic 0)	(logic 0)	(logic 1)
13	CURRENT AREA B/ \overline{A}	CURRENT AREA B/A	CURRENT AREA A/B	CURRENT AREA B/A
12	MESSAGE STOP-ON-ERROR	MESSAGE MONITOR ENABLED (MMT)	MESSAGE MONITOR ENABLED (MMT)	MESSAGE MONITOR ENABLED (MMT)
11	FRAME STOP-ON-ERROR	$\overline{\text{DYNAMIC BUS CONTROL ACCEPTANCE}}$	S10	TRIGGER ENABLED WORD
10	STATUS SET STOP-ON-MESSAGE	$\overline{\text{BUSY}}$	S09	START-ON-TRIGGER
9	STATUS SET STOP-ON-FRAME	$\overline{\text{SERVICE REQUEST}}$	S08	STOP-ON-TRIGGER
8	FRAME AUTO-REPEAT	$\overline{\text{SUBSYSTEM FLAG}}$	S07	NOT USED
7	EXTERNAL TRIGGER ENABLED	$\overline{\text{RTFLAG}}$	S06	EXTERNAL TRIGGER ENABLED
6	INTERNAL TRIGGER ENABLED	NOT USED	S05	NOT USED
5	INTERMESSAGE GAP TIMER ENABLED	NOT USED	S04	NOT USED
4	RETRY ENABLED	NOT USED	S03	NOT USED
3	DOUBLED/ $\overline{\text{SINGLE}}$ RETRY	NOT USED	S02	NOT USED
2	BC ENABLED (Read Only)	NOT USED	S01	MONITOR ENABLED (Read Only)
1	BC FRAME IN PROGRESS (Read Only)	NOT USED	S00	MONITOR TRIGGERED (Read Only)
0 (LSB)	BC MESSAGE IN PROGRESS (Read Only)	RT MESSAGE IN PROGRESS (Read Only)	RT MESSAGE IN PROGRESS (Read Only)	MONITOR ACTIVE (Read Only)

TABLE 7. CONFIGURATION REGISTER #2 (READ/WRITE 02H)

BIT	DESCRIPTION
15(MSB)	ENHANCED INTERRUPTS
14	LOGIC "0"
13	BUSY LOOKUP TABLE ENABLE
12	RX SA DOUBLE BUFFER ENABLE
11	OVERWRITE INVALID DATA
10	256-WORD BOUNDARY DISABLE
9	TIME TAG RESOLUTION 2 (TTR2)
8	TIME TAG RESOLUTION 1 (TTR1)
7	TIME TAG RESOLUTION 0 (TTR0)
6	CLEAR TIME TAG ON SYNCHRONIZE
5	LOAD TIME TAG ON SYNCHRONIZE
4	INTERRUPT STATUS AUTO CLEAR
3	LEVEL/ $\overline{\text{PULSE}}$ INTERRUPT REQUEST
2	CLEAR SERVICE REQUEST
1	ENHANCED RT MEMORY MANAGEMENT
0(LSB)	SEPARATE BROADCAST DATA

TABLE 8. START/RESET REGISTER (WRITE 03H)

BIT	DESCRIPTION
15(MSB)	RESERVED
•	•
•	•
•	•
7	RESERVED
6	BC/MT STOP-ON-MESSAGE
5	BC STOP-ON-FRAME
4	TIME TAG TEST CLOCK
3	TIME TAG RESET
2	INTERRUPT RESET
1	BC/MT START
0(LSB)	RESET

TABLE 9. BC/RT COMMAND STACK POINTER REG. (READ 03H)

BIT	DESCRIPTION
15(MSB)	COMMAND STACK POINTER 15
•	•
•	•
•	•
0(LSB)	COMMAND STACK POINTER 0

TABLE 10. BC CONTROL WORD REGISTER (READ/WRITE 04H)

BIT	DESCRIPTION
15(MSB)	RESERVED
14	M.E. MASK
13	SERVICE REQUEST BIT MASK
12	SUBSYS BUSY BIT MASK
11	SUBSYS FLAG BIT MASK
10	TERMINAL FLAG BIT MASK
9	RESERVED BITS MASK
8	RETRY ENABLED
7	BUS CHANNEL A/B
6	OFF LINE SELF TEST
5	MASK BROADCAST BIT
4	EOM INTERRUPT ENABLE
3	1553A/B SELECT
2	MODE CODE FORMAT
1	BROADCAST FORMAT
0(LSB)	RT-RT FORMAT

TABLE 11. RT SUBADDRESS CONTROL WORD (READ/WRITE 04H)

BIT	DESCRIPTION
15(MSB)	RX: DOUBLE BUFFER ENABLE
14	TX: EOM INT
13	TX: CIRC BUF INT
12	TX: MEMORY MANAGEMENT 2 (MM2)
11	TX: MEMORY MANAGEMENT 1 (MM1)
10	TX: MEMORY MANAGEMENT 0 (MM0)
9	RX: EOM INT
8	RX: CIRC BUF INT
7	RX: MEMORY MANAGEMENT 2 (MM2)
6	RX: MEMORY MANAGEMENT 1 (MM1)
5	RX: MEMORY MANAGEMENT 0 (MM0)
4	BCST: EOM INT
3	BCST: CIRC BUF INT
2	BCST: MEMORY MANAGEMENT 2 (MM2)
1	BCST: MEMORY MANAGEMENT 1 (MM1)
0(LSB)	BCST: MEMORY MANAGEMENT 0 (MM0)

TABLE 12. TIME TAG REGISTER (READ/WRITE 05H)

BIT	DESCRIPTION
15(MSB)	TIME TAG 15
•	•
•	•
•	•
0(LSB)	TIME TAG 0

TABLE 13. INTERRUPT STATUS REGISTER (READ 06H)

BIT	DESCRIPTION
15(MSB)	MASTER INTERRUPT
14	RAM PARITY ERROR
13	BC/RT TRANSMITTER TIMEOUT
12	BC/RT COMMAND STACK ROLLOVER
11	MT COMMAND STACK ROLLOVER
10	MT DATA STACK ROLLOVER
9	HS FAIL
8	BC RETRY
7	RT ADDRESS PARITY ERROR
6	TIME TAG ROLLOVER
5	RT CIRCULAR BUFFER ROLLOVER
4	BC/RT SELECTIVE MESSAGE
3	BC END OF FRAME
2	FORMAT ERROR
1	BC STATUS SET/RT MODE CODE /MT PATTERN TRIGGER
0(LSB)	END OF MESSAGE

TABLE 14. CONFIGURATION REGISTER #3 (READ/WRITE 07H)

BIT	DESCRIPTION
15(MSB)	ENHANCED MODE ENABLE
14	BC/RT COMMAND STACK SIZE 1
13	BC/RT COMMAND STACK SIZE 0
12	MT COMMAND STACK SIZE 1
11	MT COMMAND STACK SIZE 0
10	MT DATA STACK SIZE 2
9	MT DATA STACK SIZE 1
8	MT DATA STACK SIZE 0
7	ILLEGALIZATION DISABLED
6	OVERRIDE MODE T/R ERROR
5	ALTERNATE STATUS WORD ENABLE
4	ILLEGAL RX TRANSFER DISABLE
3	BUSY RX TRANSFER DISABLE
2	RTFAIL-FLAG WRAP ENABLE
1	1553A MODE CODES ENABLE
0(LSB)	ENHANCED MODE CODE HANDLING

TABLE 15. CONFIGURATION REGISTER #4 (READ/WRITE 08H)	
BIT	DESCRIPTION
15(MSB)	EXTERNAL BIT WORD ENABLE
14	INHIBIT BIT WORD IF BUSY
13	MODE COMMAND OVERRIDE BUSY
12	EXPANDED BC CONTROL WORD ENABLE
11	BROADCAST MASK ENABLE/ \overline{XOR}
10	RETRY IF -A AND M.E.
9	RETRY IF STATUS SET
8	1ST RETRY ALT/ \overline{SAME} BUS
7	2ND RETRY ALT/ \overline{SAME} BUS
6	VALID M.E./NO DATA
5	VALID BUSY/NO DATA
4	MT TAG GAP OPTION
3	LATCH RT ADDRESS WITH CONFIG #5
2	TEST MODE 2
1	TEST MODE 1
0(LSB)	TEST MODE 0

TABLE 16. CONFIGURATION REGISTER #5 (READ/WRITE 09H)	
BIT	DESCRIPTION
15(MSB)	12MHZ CLOCK SELECT
14	SINGLE ENDED SELECT
13	EXTERNAL TX INHIBIT A, read only
12	EXTERNAL TX INHIBIT B, read only
11	EXPANDED CROSSING ENABLED
10	RESPONSE TIMEOUT SELECT 1
9	RESPONSE TIMEOUT SELECT 0
8	GAP CHECK ENABLED
7	BROADCAST DISABLED
6	RT ADDRESS LATCH/ $\overline{TRANSPARENT}$ (see NOTE)
5	RT ADDRESS 4
4	RT ADDRESS 3
3	RT ADDRESS 2
2	RT ADDRESS 1
1	RT ADDRESS 0
0(LSB)	RT ADDRESS PARITY

Note: Read only, logic "0" for 61582, logic "1" for 61583.

TABLE 17. MONITOR DATA STACK ADDRESS REGISTER (READ/WRITE 0AH)	
BIT	DESCRIPTION
15(MSB)	MONITOR DATA STACK ADDRESS 15
•	•
•	•
•	•
0(LSB)	MONITOR DATA STACK ADDRESS 0

TABLE 18. BC FRAME TIME REMAINING REGISTER (READ/WRITE 0BH)	
BIT	DESCRIPTION
15(MSB)	BC FRAME TIME REMAINING 15
•	•
•	•
•	•
0(LSB)	BC FRAME TIME REMAINING 0

Note: resolution 100 μ s per LSB

TABLE 19. BC MESSAGE TIME REMAINING REGISTER (READ/WRITE 0CH)	
BIT	DESCRIPTION
15(MSB)	BC MESSAGE TIME REMAINING 15
•	•
•	•
•	•
0(LSB)	BC MESSAGE TIME REMAINING 0

Note: resolution = 1 μ s per LSB

TABLE 20. BC FRAME TIME/RT LAST COMMAND/TRIGGER REGISTER (READ/WRITE 0DH)	
BIT	DESCRIPTION
15(MSB)	BIT 15
•	•
•	•
•	•
0(LSB)	BIT 0

TABLE 21. RT STATUS WORD REGISTER (READ/WRITE 0EH)	
BIT	DESCRIPTION
15(MSB)	LOGIC "0"
14	LOGIC "0"
13	LOGIC "0"
12	LOGIC "0"
11	LOGIC "0"
10	MESSAGE ERROR
9	INSTRUMENTATION
8	SERVICE REQUEST
7	RESERVED
6	RESERVED
5	RESERVED
4	BROADCAST COMMAND RECEIVED
3	BUSY
2	SUBSYSTEM FLAG
1	DYNAMIC BUS CONTROL ACCEPT
0(LSB)	TERMINAL FLAG

TABLE 22. RT BIT WORD REGISTER (WRITE 0FH)

BIT	DESCRIPTION
15(MSB)	TRANSMITTER TIMEOUT
14	LOOP TEST FAILURE B
13	LOOP TEST FAILURE A
12	HANDSHAKE FAILURE
11	TRANSMITTER SHUTDOWN B
10	TRANSMITTER SHUTDOWN A
9	TERMINAL FLAG INHIBITED
8	CHANNEL B/ \bar{A}
7	HIGH WORD COUNT
6	LOW WORD COUNT
5	INCORRECT SYNC RECEIVED
4	PARITY/MANCHESTER ERROR RECEIVED
3	RT-RT GAP/SYNCH/ADDRESS ERROR
2	RT-RT NO RESPONSE ERROR
1	RT-RT 2ND COMMAND WORD ERROR
0(LSB)	COMMAND WORD CONTENTS ERROR

TABLE 24. RT MODE BLOCK STATUS WORD

BIT	DESCRIPTION
15(MSB)	EOM
14	SOM
13	CHANNEL B/ \bar{A}
12	ERROR FLAG
11	RT-RT FORMAT
10	FORMAT ERROR
9	NO RESPONSE TIMEOUT
8	LOOP TEST FAIL
7	DATA STACK ROLLOVER
6	ILLEGAL COMMAND WORD
5	WORD COUNT ERROR
4	INCORRECT SYNC
3	INVALID WORD
2	RT-RT GAP/SYNCH/ADDRESS ERROR
1	RT-RT 2ND COMMAND ERROR
0(LSB)	COMMAND WORD CONTENTS ERROR

TABLE 25. WORD MONITOR IDENTIFICATION WORD

BIT	DESCRIPTION
15(MSB)	GAP TIME
•	•
•	•
•	•
8	GAP TIME
7	WORD FLAG
6	$\overline{\text{THIS RT}}$
5	$\overline{\text{BROADCAST}}$
4	ERROR
3	$\overline{\text{COMMAND/DATA}}$
2	CHANNEL B/ \bar{A}
1	$\overline{\text{CONTIGUOUS DATA/GAP}}$
0(LSB)	$\overline{\text{MODE CODE}}$

NOTE:
TABLES 23 TO 26 ARE NOT REGISTERS, BUT
THEY ARE WORDS STORED IN RAM.

TABLE 23. BC MODE BLOCK STATUS WORD

BIT	DESCRIPTION
15(MSB)	EOM
14	SOM
13	CHANNEL B/ \bar{A}
12	ERROR FLAG
11	STATUS SET
10	FORMAT ERROR
9	NO RESPONSE TIMEOUT
8	LOOP TEST FAIL
7	MASKED STATUS SET
6	RETRY COUNT 1
5	RETRY COUNT 0
4	GOOD DATA BLOCK TRANSFER
3	WRONG STATUS ADDRESS/NO GAP
2	WORD COUNT ERROR
1	INCORRECT SYNC TYPE
0(LSB)	INVALID WORD

TABLE 26. MESSAGE MONITOR MODE BLOCK STATUS WORD

BIT	DESCRIPTION
15(MSB)	EOM
14	SOM
13	CHANNEL B/ \bar{A}
12	ERROR FLAG
11	RT-RT TRANSFER
10	FORMAT ERROR
9	NO RESPONSE TIMEOUT
8	GOOD DATA BLOCK TRANSFER
7	DATA STACK ROLLOVER
6	RESERVED
5	WORD COUNT ERROR
4	INCORRECT SYNC
3	INVALID WORD
2	RT-RT GAP/SYNCH/ADDRESS ERROR
1	RT-RT 2ND COMMAND ERROR
0(LSB)	COMMAND WORD CONTENTS ERROR

BC CONTROLLER (BC) ARCHITECTURE

The BC protocol of the BU-61582 implements all MIL-STD-1553B message formats. Message format is programmable on a message-by-message basis by means of bits in the BC Control Word and the T/R bit of the Command Word for the respective message. The BC Control Word allows 1553 message format, 1553A/B type RT, bus channel, self-test, and Status Word masking to be specified on an individual message basis. In addition, automatic retries and/or interrupt requests may be enabled or disabled for individual messages. The BC performs all error checking required by MIL-STD-1553B. This includes validation of response time, sync type and sync encoding, Manchester II encoding, parity, bit count, word count, Status Word RT Address field, and various RT-to-RT transfer errors. The BU-61582's BC response timeout value is programmable with choices of 18, 22, 50, and 130 μ s. The longer response timeout values allow for operation over long buses and/or the use of repeaters. FIGURE 2 illustrates BC intermessage gap and frame timing.

The BU-61582 may be programmed to process BC frames of up to 512 messages with no processor intervention. It is possible to program for either single frame or frame auto-repeat operation. In the auto-repeat mode, the frame repetition rate may be controlled either internally, using a programmable BC frame timer, or from an external trigger input. The internal BC frame time is programmable up to 6.55 seconds in increments of 100 μ s. In addition to BC frame time, intermessage gap time, defined as the start of the current message to the start of the subsequent message, is programmable on an individual message basis. The time between individual successive messages is programmable up to 65.5 ms, in increments of 1 μ s.

BC MEMORY ORGANIZATION

TABLE 27 illustrates a typical memory map for BC mode. It is important to note that the only fixed locations for the BU-61582 in the Standard BC mode are for the two Stack Pointers (address locations 0100 (hex) and 0104) and for the two Message Count locations (0101 and 0105). Enabling the Frame Auto-Repeat mode will reserve four more memory locations for use in the Enhanced BC mode; these locations are for the two Initial Stack Pointers (address locations 102 (hex) and 106) and for the Initial

TABLE 27. TYPICAL BC MEMORY ORGANIZATION (SHOWN FOR 4K RAM)	
ADDRESS (HEX)	DESCRIPTION
0000-00FF	Stack A
0100	Stack Pointer A (fixed location)
0101	Message Count A (fixed location)
0102	Initial Stack Pointer A (see note) (Auto-Frame Repeat Mode)
0103	Initial Message Count A (see note) (Auto-Frame Repeat Mode)
0104	Stack Pointer B
0105	Message Count B
0106	Initial Stack Pointer B (see note) (Auto-Frame Repeat Mode)
0107	Initial Message Count B (see note) (Auto-Frame Repeat Mode)
0108-012D	Message Block 0
012E-0153	Message Block 1
0154-0179	Message Block 2
•	•
•	•
•	•
3EC8-3EED	Message Block 416
3EEE-3EFF	Not Used
3F00-3FFF	Stack B

Note: Used only in the Enhanced BC mode with Frame Auto-Repeat enabled.

Message Count locations (103 and 107). The user is free to locate the Stack and BC Message Blocks anywhere else within the 64K (16K internal) shared RAM address space.

For simplicity of illustration, assume the allocation of the maximum length of a BC message for each message block in the typical BC memory map of TABLE 27. The maximum size of a BC message block is 38 words, for an RT-to-RT transfer of 32 Data Words (Control + 2 Commands + Loopback + 2 Status Words + 32 Data Words). Note, however, that this example assumes the disabling of the 256-word boundaries.

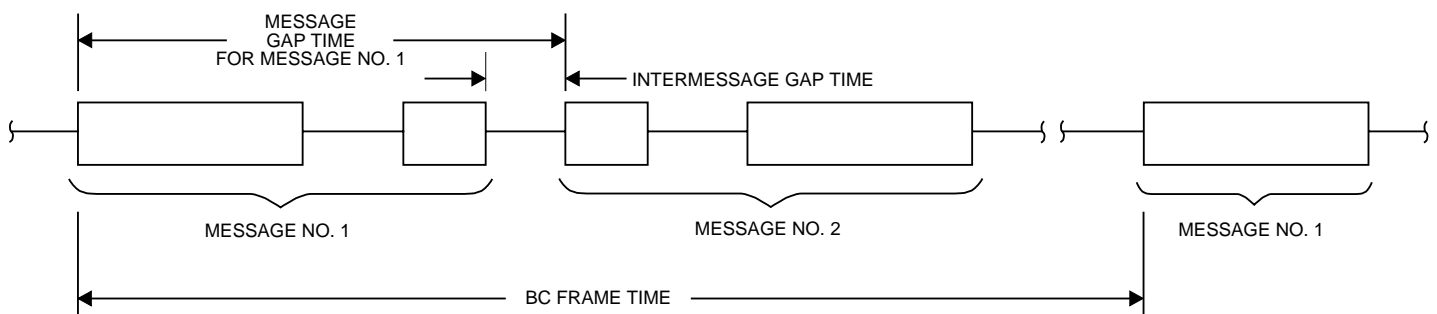

FIGURE 2. BC MESSAGE GAP AND FRAME TIMING

BC MEMORY MANAGEMENT

FIGURE 3 illustrates the BU-61582's BC memory management scheme. One of the BC memory management features is the global double buffering mechanism. This provides for two sets of the various BC mode data structures: Stack Pointer and Message Counter locations, Descriptor Stack areas, and BC message blocks. Bit 13 of Configuration Register #1 selects the current active area. At any point in time, the BU-61582's internal 1553 memory management logic may access only the various data structures within the "active" area. FIGURE 3 delineates the "active" and "inactive" areas by the nonshaded and shaded areas, respectively; however, at any point in time, both the "active" and "nonactive" areas are accessible by the host processor. In most applications, the host processor will access the "non-active" area, while the 1553 bus processes the "active" area messages.

The BC may be programmed to transmit multimessage frames of up to 512 messages. The number of messages to be processed is programmable by the Active Area Message Count location in the shared RAM, initialized by the host processor. In addition, the host processor must initialize another location, the Active Area Stack Pointer. The Stack Pointer references the four-word message block descriptor in the Stack area of shared RAM for each message to be processed. The BC Stack size is programmable with choices of 256, 512, 1024, and 2048 words.

In the BC Frame Auto-Repeat mode, the Initial Stack Pointer and Initial Message Counter locations must be loaded by the host prior to the processing of the first frame. The single frame mode does not use these two locations.

The third and fourth words of the BC block descriptor are the Intermessage Gap Time and the Message Block Address for the respective message. These two memory locations must be written by the host processor prior to the start of message processing. Use of the Intermessage Gap Time is optional. The Block Address pointer specifies the starting location for each message block. The first word of each BC message block is the BC Control Word.

At the start and end of each message, the Block Status and Time Tag Words write to the message block descriptor in the stack. The Block Status Word includes indications of message in process or message completion, bus channel, Status Set, response timeout, retry count, Status address mismatch, loop test (on-line self-test) failure, and other error conditions. TABLE 23 illustrates the bit mapping of the BC Block Status word. The 16-bit Time Tag Word will reflect the current contents of the internal Time Tag Register. This read/writable register, which operates for all three modes, has programmable resolution of from 2 to 64 μ s/LSB. In addition, the Time Tag register may be clocked from an external source.

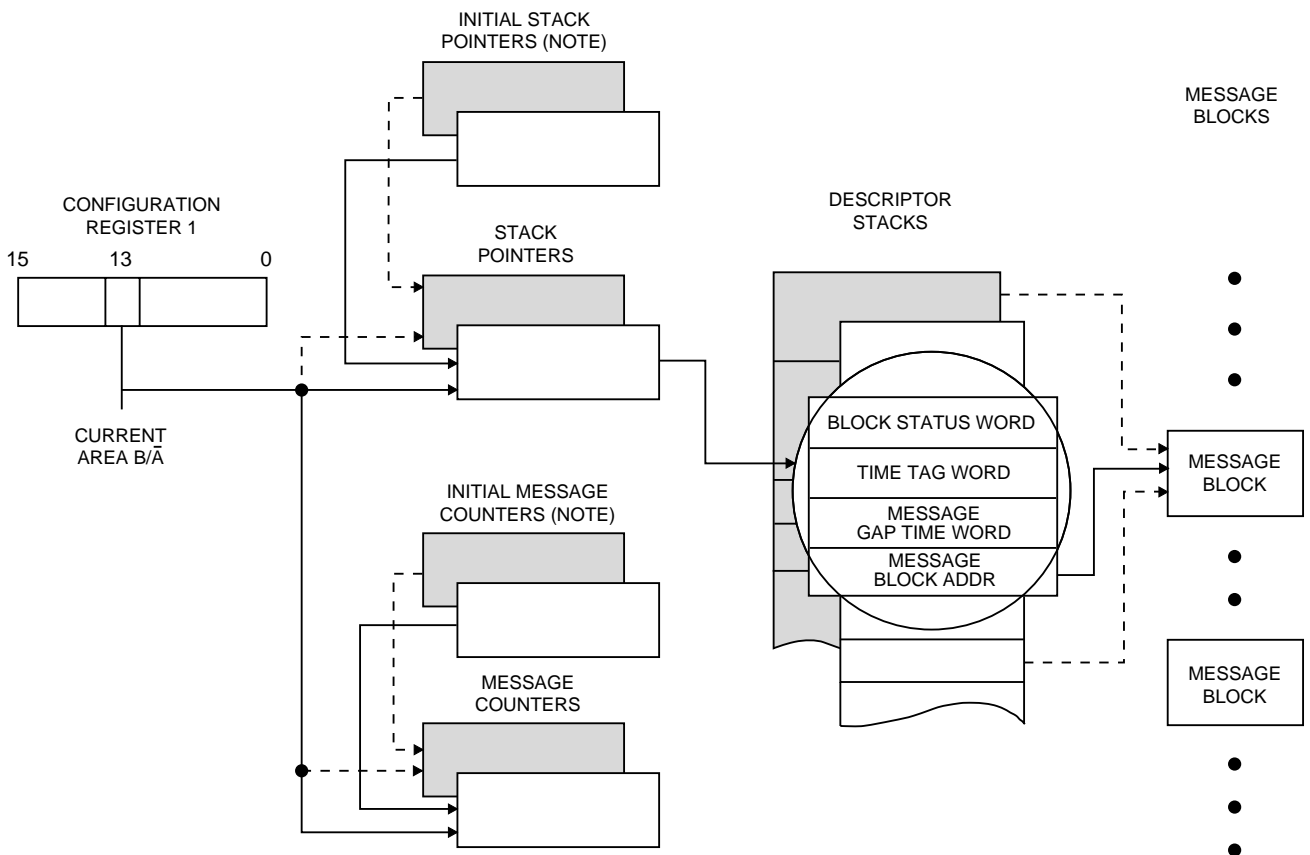

FIGURE 3. BC MODE MEMORY MANAGEMENT

BC MESSAGE BLOCK FORMATS AND BC CONTROL WORD

In BC mode, the BU-61582 supports all MIL-STD-1553 message formats. For each 1553 message format, the BU-61582 mandates a specific sequence of words within the BC Message Block. This includes locations for the Control, Command and (transmitted) Data Words that are to be read from RAM by the

BC-to-RT Transfer		RT-to-BC Transfer	
Control Word		Control Word	
Receive Command Word		Transmit Command Word	
Data Word #1		Transmit Command Looped Back	
Data Word #2		Status Received	
.		Data Word #1	
.		Data Word #2	
.		.	
Last Data Word		.	
Last Data Word Looped Back		.	
Status Received		Last Data Word	

RT-to-RT Transfer	Mode Code; No Data	Tx Mode Code; With Data
Control Word	Control Word	Control Word
Receive Command	Mode Command	Tx Mode Command
Transmit Command	Mode Command Looped Back	Mode Command Looped Back
Transmit Command Looped Back	Status Received	Status Received
Tx RT Status Word		Data Word
Data #1		
Data #2		
.		
.		
.		
Last Data		
Rx RT Status Word		

Rx Mode Code; With Data	Broadcast	RT-to-RTs (Broadcast) Transfer
Control Word	Control Word	Control Word
Rx Mode Command	Broadcast Command	Rx Broadcast Command
Data Word	Data #1	Tx Command
Data Word Looped Back	Data #2	Tx Command Looped Back
Status Received	.	Tx RT Status Word
	.	Data #1
	.	Data #2
	Last Data	.
	Last Data Status Word	.
		.
		Last Data

Broadcast Mode Code; No Data	Broadcast Mode Code; With Data
Control Word	Control Word
Broadcast Mode Command	Broadcast Mode Command
Broadcast Mode Command Looped Back	Data Word
	Data Word Looped Back

FIGURE 4. BC MESSAGE BLOCK FORMATS

BC protocol logic. In addition, subsequent contiguous locations must be allocated for storage of received Loopback, RT Status and Data Words. FIGURE 4 illustrates the organization of the BC message blocks for the various MIL-STD-1553 message formats. Note that for all of the message formats, the BC Control Word is located in the first location of the message block.

The BC Control Word is not transmitted on the 1553 bus. Instead, it contains bits that select the active bus and message format, enable off-line self-test, masking of Status Word bits, enable retries and interrupts, and specify MIL-STD-1553A or -1553B error handling. The bit mapping and definitions of the BC Control Word are illustrated in TABLE 10.

The BC Control Word is followed by the Command Word to be transmitted, and subsequently by a second Command Word (for an RT-to-RT transfer), followed by Data Words to be transmitted (for Receive commands). The location after the last word to be transmitted is reserved for the Loopback Word. The loopback Word is an on-line self-test feature. The subsequent locations after the Loopback Word are reserved for received Status Words and Data Words (for Transmit commands).

AUTOMATIC RETRIES

The BU-61582 BC implements automatic message retries. When enabled, retries will occur, following response timeout or format error conditions. As additional options, retries may be enabled when the Message Error Status Word bit is set by a 1553A RT or following a "Status Set" condition. For a failed message, either one or two message retries will occur, the bus channel (same or alternate) is independently programmable for the first and second retry attempts. Retries may be enabled or disabled on an individual message basis.

BC INTERRUPTS

BC interrupts may be enabled by the Interrupt Mask Register for Stack Rollover, Retry, End-of-Message (global), End-of-Message (in conjunction with the BC Control Word for individual messages), response timeout, message error, end of BC frame, and Status Set conditions. The definition of "Status Set" is programmable on an individual message basis by means of the BC Control Word. This allows for masking ("care/don't care") for the individual RT Status Word bits.

REMOTE TERMINAL (RT) ARCHITECTURE

The RT protocol design of the BU-61582 represents DDC's fifth generation implementation of a 1553 RT. One of the salient features of the SP'ACE's RT architecture is its true multiprotocol functionality. This includes programmable options for support of MIL-STD-1553A, the various McAir protocols, and MIL-STD-1553B Notice 2. The BU-61582 RT response time is 2 to 5 μ s dead time (4 to 7 μ s per 1553B), providing compliance to all the 1553 protocols. Additional multiprotocol features of the BU-61582 include options for full software control of RT Status and Built-in-Test (BIT) words. Alternatively, for 1553B applications,

these words may be formulated in real time by the BU-61582 protocol logic.

The BU-61582 RT protocol design implements all the MIL-STD-1553B message formats and dual redundant mode codes. This design is based largely on previous generation products that have passed SEAFAC testing for MIL-STD-1553B compliance. The SP'ACE RT performs comprehensive error checking, word and format validation, and checks for various RT-to-RT transfer errors. Other key features of the BU-61582 RT include a set of interrupt conditions, internal command illegalization, and programmable busy by subaddress.

RT MEMORY ORGANIZATION

TABLE 28 illustrates a typical memory map for the SP'ACE in RT mode. As in BC mode, the two Stack Pointers reside in fixed locations in the shared RAM address space: address 0100 (hex) for the Area A Stack Pointer and address 0104 for the Area B Stack Pointer. Besides the Stack Pointer, for RT mode there are several other areas of the BU-61582 address space designated as fixed locations. All RT modes of operation require the Area A and Area B Lookup Tables. Also allocated, are several fixed locations for optional features: Command Illegalization Lookup Table, Mode Code Selective Interrupt Table, Mode Code Data Table, and Busy Bit Lookup Table. It should be noted that any unenabled optional fixed locations may be used for general purpose storage (data blocks).

The RT Lookup tables, which provide a mechanism for mapping data blocks for individual Tx/Rx/Bcst-subaddresses to areas in the RAM, occupy address range locations are 0140 to 01BF for Area A and 01C0 to 023F for Area B. The RT lookup tables include Subaddress Control Words and the individual Data Block Pointers. If used, address range 0300-03FF will be dedicated as the illegalizing section of RAM. The actual Stack RAM area and the individual data blocks may be located in any of the nonfixed areas in the shared RAM address space.

RT MEMORY MANAGEMENT

Another salient feature of the SP'ACE series products is the flexibility of its RT memory management architecture. The RT architecture allows the memory management scheme for each transmit, receive, or broadcast subaddress to be programmable on a subaddress basis. Also, in compliance with MIL-STD-1553B Notice 2, the BU-61582 provides an option to separate data received from broadcast messages from nonbroadcast received data.

Besides supporting a global double buffering scheme (as in BC mode), the SP'ACE RT provides a pair of 128-word Lookup Tables for memory management control, programmable on a subaddress basis (refer to TABLE 29). The 128-word tables include 32-word tables for transmit message pointers and receive message pointers. There is also a third, optional Lookup

TABLE 28. TYPICAL RT MEMORY MAP (SHOWN FOR 16K RAM)	
ADDRESS (HEX)	DESCRIPTION
0000-00FF	Stack A
0100	Stack Pointer A (fixed location)
0101-0103	RESERVED
0104	Stack Pointer B (fixed location)
0105-0107	RESERVED
0108-010F	Mode Code Selective Interrupt Table (fixed area)
0110-013F	Mode Code Data (fixed area)
0140-01BF	Lookup Table A (fixed area)
01C0-023F	Lookup Table B (fixed area)
0240-0247	Busy Bit Lookup Table (fixed area)
0248-025F	(not used)
0260-027F	Data Block 0
0280-02FF	Data Block 1-4
0300-03FF	Command Illegalizing Table (fixed area)
0400-041F	Data Block 5
0420-043F	Data Block 6
•	•
•	•
•	•
3FE0-3FFF	Data Block 476

Table for broadcast message pointers, providing Notice 2 compliance, if necessary.

RT MEMORY MANAGEMENT

Another salient feature of the SP'ACE series products is the flexibility of its RT memory management architecture. The RT architecture allows the memory management scheme for each transmit, receive, or broadcast subaddress to be programmable on a subaddress basis. Also, in compliance with MIL-STD-1553B Notice 2,

TABLE 29. LOOK-UP TABLES			
AREA A	AREA B	DESCRIPTION	COMMENT
0140	01C0	Rx(/Bcst)_SA0	Receive (/Broadcast) Lookup Table
•	•	•	
•	•	•	
015F	01DF	Rx(/Bcst)_SA31	
0160	01E0	Tx_SA0	Transmit Lookup Table
•	•	•	
•	•	•	
017F	01FF	Tx_SA31	
0180	0200	Bcst_SA0	Broadcast Lookup Table Optional
•	•	•	
•	•	•	
019F	021F	Bcst_SA31	
01A0	0220	SACW_SA0	Subaddress Control Word Lookup Table (Optional)
•	•	•	
•	•	•	
•	•	•	
01BF	023F	SACW_SA31	

TABLE 30. SUBADDRESS CONTROL WORD MEMORY MANAGEMENT SUBADDRESS BUFFER SCHEME

MM2	MM1	MM0	DESCRIPTION	COMMENT
0	0	0	Single Message or Double Buffered	
0	0	1	128-Word	Circular Buffer of Specified Size
0	1	0	256-Word	
0	1	1	512-Word	
1	0	0	1024-Word	
1	0	1	2048-Word	
1	1	0	4096-Word	
1	1	1	8192-Word	

the BU-61582 provides an option to separate data received from broadcast messages from nonbroadcast received data.

Besides supporting a global double buffering scheme (as in BC mode), the SP^{ACE} RT provides a pair of 128-word Lookup Tables for memory management control, programmable on a subaddress basis (refer to TABLE 29). The 128-word tables include 32-word tables for transmit message pointers and receive message pointers. There is also a third, optional Lookup Table for broadcast message pointers, providing Notice 2 compliance, if necessary.

The fourth section of each of the RT Lookup Tables stores the 32 Subaddress Control Words (refer to TABLE 11 and TABLE 30). The individual Subaddress Control Words may be used to select the RT memory management option and interrupt scheme for each transmit, receive, and (optionally) broadcast subaddress.

For each transmit subaddress, there are two possible memory management schemes: (1) single message; and (2) circular buffer. For each receive (and optionally broadcast) subaddress, there are three possible memory management schemes: (1) single message; (2) double buffered; and (3) circular buffer. For each transmit, receive and broadcast subaddress, there are two interrupt conditions programmable by the respective Subaddress Control Word: (1) after every message to the subaddress; (2) after a circular buffer rollover. An additional table in RAM may be used to enable interrupts following selected mode code messages.

When using the circular buffer scheme for a given subaddress, the size of the circular buffer is programmable by three bits of the Subaddress Control Word (see TABLE 30). The options for circular buffer size are 128, 256, 512, 1024, 2048, 4096, and 8192 Data Words.

SINGLE MESSAGE MODE

FIGURE 5 illustrates the RT Single Message memory management scheme. When operating the BU-61582 in its “AIM-HY” (default) mode, the Single Message scheme is implemented for all transmit, receive, and broadcast subaddresses. In the Single Message mode (also in the Double Buffer and Circular Buffer modes), there is a global double buffering scheme, controlled by bit 13 of Configuration Register #1. This selects from between the two sets of the various data structures shown in the figure: the Stack Pointers (fixed addresses), Descriptor Stacks (user defined addresses), RT Lookup Tables (fixed addresses), and RT Data Word blocks (user defined addresses). FIGURES 5, 6, and 7 delineate the “active” and “nonactive” areas by the non-shaded and shaded areas, respectively.

As shown, the SP^{ACE} stores the Command Word from each message received, in the fourth location within the message descriptor (in the stack) for the respective message. The T/ \bar{R} bit, subaddress field, and (optionally) broadcast/own address, index into the active area Lookup Table, to locate the data block pointer for the current message. The BU-61582 RT memory management logic then accesses the data block pointer to locate the starting address for the Data Word block for the current message. The maximum size for an RT Data Word block is 32 words.

For a particular subaddress in the Single Message mode, there is overwriting of the contents of the data blocks for receive/broadcast subaddresses – or overreading, for transmit subaddresses. In the single message mode, it is possible to access multiple data blocks for the same subaddress. This, however, requires the intervention of the host processor to update the respective Lookup Table pointer. To implement a data wraparound subaddress, as required by Notice 2 of MIL-STD-1553B, the Single Message scheme should be used for the wraparound subaddress. Notice 2 recommends subaddress 30 as the wraparound subaddress.

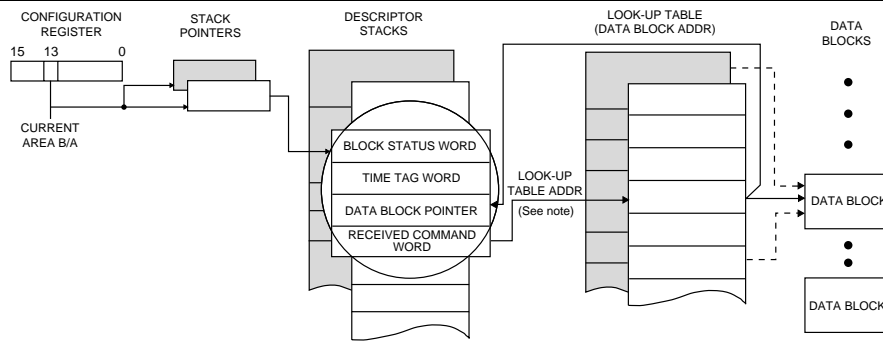

FIGURE 5. RT MEMORY MANAGEMENT: SINGLE MESSAGE MODE

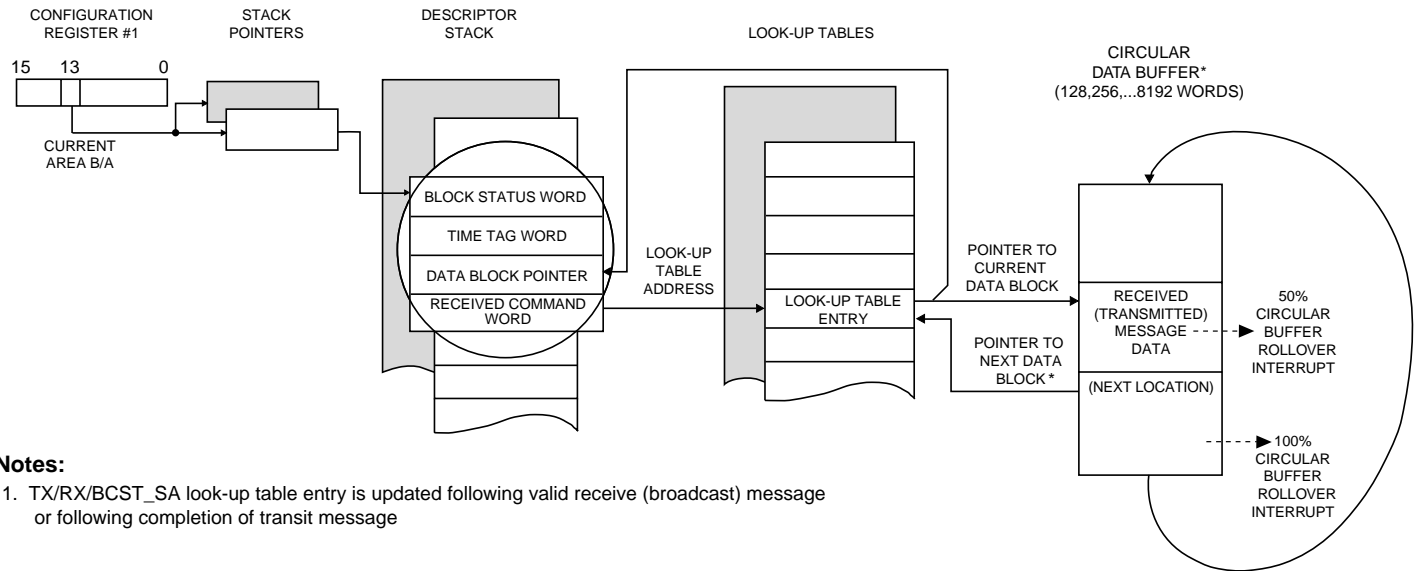

FIGURE 6. RT MEMORY MANAGEMENT: CIRCULAR BUFFER MODE

CIRCULAR BUFFER MODE

FIGURE 6 illustrates the RT circular buffer memory management scheme. The circular buffer mode facilitates bulk data transfers. The size of the RT circular buffer, shown on the right side of the figure, is programmable from 128 to 8192 words (in even powers of 2) by the respective Subaddress Control Word. As in the single message mode, the host processor initially loads the individual Lookup Table entries. At the start of each message, the SP'ACE stores the Lookup Table entry in the third position of the respective message block descriptor in the stack area of RAM, as in the Single Message mode. The SP'ACE transfers Receive or Transmit Data Words to (from) the circular buffer, starting at the location referenced by the Lookup Table pointer.

At the end of a valid (or, optionally, invalid) message, the value of the Lookup Table entry updates to the next location after the last address accessed for the current message. As a result, Data Words for the next message directed to the same Tx/RX(/Bcst) subaddress will be accessed from the next contiguous block of address locations within the circular buffer. As a recommended option, the Lookup Table pointers may be programmed to not update following an invalid receive (or broadcast) message. This allows the 1553 bus controller to retry the failed message, resulting in the valid (retried) data overwriting the invalid data. This eliminates overhead for the RT's host processor. When the pointer reaches the lower boundary of the circular buffer (located at 128, 256, . . . 8192-word boundaries in the BU-61582 address space), the pointer moves to the top boundary of the circular buffer, as FIGURE 6 shows.

IMPLEMENTING BULK DATA TRANSFERS

The use of the Circular Buffer scheme is ideal for bulk data transfers; that is, multiple messages to/from the same subaddress. The recommendation for such applications is to enable the circular buffer interrupt request. By so doing, the routine transfer of multiple messages to the selected subaddress, including errors and retries, is transparent to the RT's host processor. By strategically initializing the subaddress's Lookup Table pointer prior to the start of the bulk transfer, the BU-61582 may be configured to issue an interrupt request only after it has received the anticipated number of valid Data Words to the designated subaddress.

SUBADDRESS DOUBLE BUFFERING MODE

For receive (and broadcast) subaddresses, the BU-61582 RT offers a third memory management option, Subaddress Double Buffering. Subaddress double buffering provides a means of ensuring data consistency. FIGURE 7 illustrates the RT Subaddress Double Buffering scheme. Like the Single Message and Circular Buffer modes, the Double Buffering mode may be selected on a subaddress basis by means of the Subaddress Control Word. The purpose of the Double Buffering mode is to provide the host processor a convenient means of accessing the most recent, valid data received to a given subaddress. This serves to ensure the highest possible degree of data consistency by allocating two 32-bit Data Word blocks for each individual receive (and/or broadcast) subaddress.

At a given point in time, one of the two blocks will be designated as the "active" 1553 data block while the other will be designated as the "inactive" block. The Data Words from the next receive message to that subaddress will be stored in the "active" block.

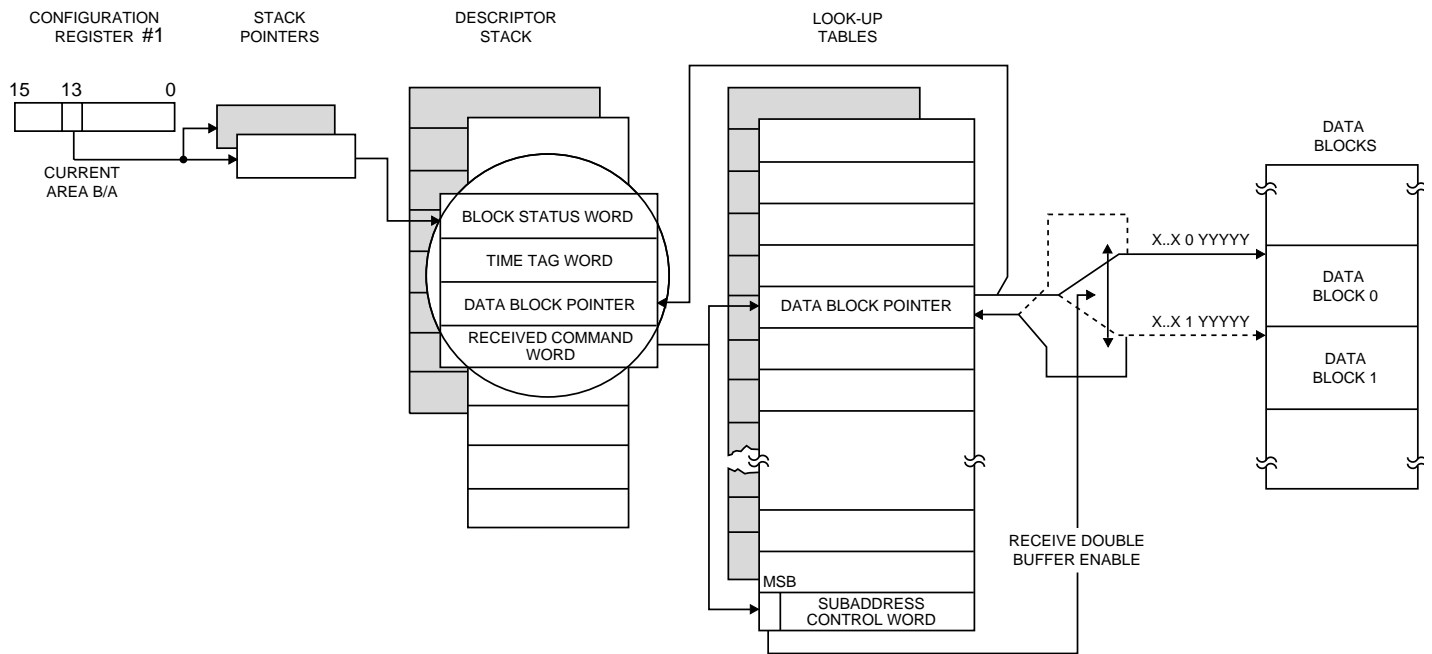

FIGURE 7. RT MEMORY MANAGEMENT: SUBADDRESS DOUBLE BUFFERING MODE

Upon completion of the message, provided that the message was valid and Subaddress Double Buffering is enabled, the BU-61582 will automatically switch the “active” and “inactive” blocks for the respective subaddress. The SP’ACE accomplishes this by toggling bit 5 of the subaddress’s Lookup Table Pointer and rewriting the pointer. As a result, the most recent valid block of received Data Words will always be readily accessible to the host processor.

As a means of ensuring data consistency, the host processor is able to reliably access the most recent valid, received Data Word block by performing the following sequence:

- (1) Disable the double buffering for the respective subaddress by the Subaddress Control Word. That is, temporarily switch the subaddress’s memory management scheme to the Single Message mode.
- (2) Read the current value of the receive (or broadcast) subaddress’s Lookup Table pointer. This points to the current “active” Data Word block. By inverting bit 5 of this pointer value, it is possible to locate the start of the “inactive” Data Word block. This block will contain the Data Words received during the most recent valid message to the subaddress.
- (3) Read out the words from the “inactive” (most recent) Data Word Block.
- (4) Re-enable the Double Buffering mode for the respective subaddress by the Subaddress Control Word.

RT INTERRUPTS

As in BC mode, the BU-61582 RT provides many maskable interrupts. RT interrupt conditions include End of (every) Message, Message Error, Selected Subaddress (Subaddress Control Word) Interrupt, Circular Buffer Rollover, Selected Mode Code Interrupt, and Stack Rollover.

DESCRIPTOR STACK

At the beginning and end of each message, the BU-61582 RT stores a four-word message descriptor in the active area stack. The RT stack size is programmable, with choices of 256, 512, 1024, and 2048 words. FIGURES 5, 6, and 7 show the four words: Block Status Word, Time Tag Word, Data Block Pointer, and the 1553 received Command Word. The RT Block Status Word includes indications of message in-progress or message complete, bus channel, RT-to-RT transfer and RT-to-RT transfer errors, message format error, loop test (self-test) failure, circular buffer rollover, illegal command, and other error conditions. TABLE 24 shows the bit mapping of the RT Block Status Word.

As in BC mode, the Time Tag Word stores the current contents of the BU-61582’s read/writable Time Tag Register. The resolution of the Time Tag Register is programmable from among 2, 4, 8, 16, 32, and 64 $\mu\text{s}/\text{LSB}$. Also, incrementing of the Time Tag counter may be from an external clock source or via software command.

The SP’ACE stores the contents of the accessed Lookup Table location for the current message, indicating the starting location of the Data Word block, as the Data Block Pointer. This serves as a convenience in locating stored message data blocks. The

SP'ACE stores the full 16-bit 1553 Command Word in the fourth location of the RT message descriptor.

RT COMMAND ILLEGALIZATION

The BU-61582 provides an internal mechanism for RT command illegalization. In addition, there is a means for allowing the setting of the Busy Status Word bit to be only for a programmed subset of the transmit/receive/broadcast subaddresses.

The illegalization scheme uses a 256-word area in the BU-61582's address space. A benefit of this feature is the reduction of printed circuit board requirements, by eliminating the need for an external PROM, PLD, or RAM device that does the illegalizing function. The BU-61582's illegalization scheme provides maximum flexibility, allowing any subset of the 4096 possible combinations of broadcast/own address, T/R bit, subaddress, and word count/mode code to be illegalized. Another advantage of the RAM-based illegalization technique is that it provides for a high degree of self-testability.

ADDRESSING THE ILLEGALIZATION TABLE.

TABLE 31 illustrates the addressing scheme of the illegalization RAM. As shown, the base address of the illegalizing RAM is 0300 (hex). The SP'ACE formulates the index into the Illegalizing Table based on the values of BROADCAST/OWNADDRESS ADDRESS, T/R bit, Subaddress, and the MSB of the Word Count/Mode Code field (WC/MC4) of the current Command Word.

The internal RAM has 256 words reserved for command illegalization. Broadcast commands may be illegalized separately from nonbroadcast receive commands and mode commands.

Commands may be illegalized down to the word count level. For example, a one-word receive command to subaddress 1 may be legal, while a two-word receive command to subaddress 1 may be illegalized.

The first 64 words of the Illegalization Table refer to broadcast receive commands (two words per subaddress). The next 64 words refer to broadcast transmit commands. Since nonmode code broadcast transmit commands are by definition invalid, this section of the table (except for subaddresses 0 and 31) does not need to be initialized by the user. The next 64 words correspond to nonbroadcast receive commands. The final 64 words refer to nonbroadcast transmit commands. Messages with Word Count/Mode Code (WC/MC) fields between 0 and 15 may be illegalized by setting the corresponding data bits for the respective even-numbered address locations in the illegalization table. Likewise, messages with WC/MC fields between 16 and 31 may be illegalized by setting the corresponding data bits for the respective odd-numbered address locations in the illegalization table.

The following should be noted with regards to command illegalization:

- (1) To illegalize a particular word count for a given broadcast/own address-T/R subaddress, the appropriate bit position in the respective illegalization word should be set to logic 1. A bit value of logic 0 designates the respective Command Word as a legal command. The BU-61582 will respond to an illegalized non-broadcast command with the Message Error bit set in its RT Status Word.
- (2) For subaddresses 00001 through 11110, the "WC/MC" field specifies the Word Count field of the respective Command Word. For subaddresses 00000 and 11111, the "WC/MC" field specifies the Mode Code field of the respective Command Word.
- (3) Since nonmode code broadcast transmit messages are not defined by MIL-STD-1553B, the sixty (60) words in the illegalization RAM, addresses 0342 through 037D, corresponding to these commands do not need to be initialized. The BU-61582 will not respond to a nonmode code broadcast transmit command, but will automatically set the Message Error bit in its internal Status Register, regardless of whether or not the corresponding bit in the illegalization RAM has been set. If the next message is a Transmit Status or Transmit Last Command mode code, the BU-61582 will respond with its Message Error bit set.

TABLE 31. ILLEGALIZATION RAM ADDRESS DEFINITION	
BIT	DESCRIPTION
15(MSB)	0
14	0
13	0
12	0
11	0
10	0
9	1
8	1
7	BROADCAST/OWN_ADDRESS
6	T/R
5	SA4
4	SA3
3	SA2
2	SA1
1	SA0
0(LSB)	WC4/MC4

PROGRAMMABLE BUSY

As a means of providing compliance with Notice 2 of MIL-STD-1553B, the BU-61582 RT provides a software controllable means for setting the Busy Status Word bit as a function of sub-address. By a Busy Lookup Table in the BU-61582 address space, it is possible to set the Busy bit based on command broadcast/own address, T/\bar{R} bit, and subaddress. Another programmable option, allows received Data Words to be either stored or not stored for messages, when the Busy bit is set.

OTHER RT FUNCTIONS

The BU-61582 allows the hardwired RT Address to be read by the host processor. Also, there are options for the RT FLAG Status Word bit to be set under software control and/or automatically following a failure of the loopback self-test. Other software controllable RT options include software programmable RT Status and RT BIT words, automatic clearing of the Service Request Status Word bit following a Transmit Vector Word mode command, capabilities to clear and/or load the Time Tag Register following receipt of Synchronize mode commands, options regarding Data Word transfers for the Busy and/or Message Error (Illegal) Status Word bits, and for handling of 1553A and reserved mode codes.

MONITOR (MT) ARCHITECTURE

The BU-61582 provides three bus monitor (MT) modes:

- (1) The "AIM-HY" (default) or "AIM-HY'er" Word Monitor mode.
- (2) A Selective Message Monitor mode.
- (3) A Simultaneous Remote Terminal/Selective Message Monitor mode.

The strong recommendation for new applications is the use of the Selective Message Monitor, rather than the Word Monitor. Besides providing monitor filtering based on RT Address, T/\bar{R} bit, and Subaddress, the Message Monitor eliminates the need to determine the start and end of messages by software. The development of such software tends to be a tedious task. Moreover, at run time, it tends to entail a high degree of CPU overhead.

WORD MONITOR

In the Word Monitor mode, the BU-61582 monitors both 1553 buses. After initializing the Word Monitor and putting it on-line the BU-61582 stores all Command, Status, and Data Words received from both buses. For each word received from either bus, the BU-61582 stores a pair of words in RAM. The first word is the 16 bits of data from the received word. The second word is the Monitor Identification (ID), or "Tag" word. The ID Word contains information relating to bus channel, sync type, word validity, and interword time gaps. The BU-61582 stores data and ID

words in a circular buffer in the shared RAM address space. TABLE 25 shows the bit mapping for the Monitor ID word.

MONITOR TRIGGER WORD

There is a Trigger Word Register that provides additional flexibility for the Word Monitor mode. The BU-61582 stores the value of the 16-bit Trigger Word in the MT Trigger Word Register. The contents of this register represent the value of the Trigger Command Word. The BU-61582 has programmable options to start or stop the Word Monitor, and/or to issue an interrupt request following receipt of the Trigger Command Word from the 1553 bus.

SELECTIVE MESSAGE MONITOR MODE

The BU-61582 Selective Message Monitor provides features to greatly reduce the software and processing burden of the host CPU. The Selective Message Monitor implements selective monitoring of messages from a dual 1553 bus, with the monitor filtering based on the RT Address, T/\bar{R} bit, and Subaddress fields of received 1553 Command Words. The Selective Message Monitor mode greatly simplifies the host processor software by distinguishing between Command and Status Words. The Selective Message Monitor maintains two stacks in the BU-61582 RAM: a Command Stack and a Data Stack.

SIMULTANEOUS RT/MESSAGE MONITOR MODE

The Selective Message Monitor may function as a purely passive monitor or may be programmed to function as a simultaneous RT/Monitor. The RT/Monitor mode provides complete Remote Terminal (RT) operation for the BU-61582's strapped RT address and bus monitor capability for the other 30 non-broadcast RT addresses. This allows the BU-61582 to simultaneously operate as a full function RT and "snoop" on all or a subset of the bus activity involving the other RTs on a bus. This type of operation is sometimes needed to implement a backup bus controller. The combined RT/Selective Monitor maintains three stack areas in the BU-61582 address space: an RT Command Stack, a Monitor Command Stack, and a Monitor Data Stack. The pointers for the various stacks have fixed locations in the BU-61582 address space.

SELECTIVE MESSAGE MONITOR MEMORY ORGANIZATION

TABLE 32 illustrates a typical memory map for the SP'ACE in the Selective Message Monitor mode. This mode of operation defines several fixed locations in the RAM. These locations allocate in a manner that is compatible with the combined RT/Selective Message Monitor mode. Refer to TABLE 32 for an example of a typical Selective Message Monitor Memory Map. The fixed memory map consists of two Monitor Command Stack Pointers (location 102h and 106h), two Monitor Data Stack Pointers (locations 103h and 107h), and a Selective Message Monitor Lookup Table (0280-02FFh) based on RT Address T/\bar{R} , and subaddress. Assume a Monitor Command Stack size of 1K words, and a Monitor Data Stack size of 4K words.

TABLE 32. TYPICAL SELECTIVE MESSAGE MONITOR MEMORY MAP (SHOWN FOR 16K RAM)

ADDRESS (HEX)	DESCRIPTION
0000-0101	Not Used
0102	Monitor Command Stack Pointer A (fixed location)
0103	Monitor Data Stack Pointer A (fixed location)
0104-0105	Not Used
0106	Monitor Command Stack Pointer B (fixed location)
0107	Monitor Data Stack Pointer B (fixed location)
0108-027F	Not Used
0280-02FF	Selective Monitor Lookup Table (fixed area)
0300-03FF	Not Used
0400-07FF	Monitor Command Stack A (1K words)
0800-3FFF	Monitor Command Stack B (1K words)
0C00-0FFF-	Not Used (1K words)
1000-1FFF	Monitor Data Stack A (4K words)
2000-2FFF	Monitor Data Stack B (4K words)
3000-3FFF	Not Used (4K words)

Refer to FIGURE 8 for an illustration of the Selective Message Monitor operation. Upon receipt of a valid Command Word, the BU-61582 will reference the Selective Monitor Lookup Table (a fixed block of addresses) to check for the condition (disabled/enabled) of the current command. If disabled, the BU-

61582 will ignore (and not store) the current message; if enabled, the BU-61582 will create an entry in the Monitor Command Stack at the address location referenced by the Monitor Command Stack Pointer.

Similar to RT mode, The SP'ACE stores a Block Status Word, 16-bit Time Tag Word, and Data Block Pointer in the Message Descriptor, along with the received 1553 Command Word following reception of the Command Word. The SP'ACE writes the Block Status and Time Tag Words at both the start and end of the message. The Monitor Block Status Word contains indications of message in-progress or message complete, bus channel, Monitor Data Stack Rollover, RT-to-RT transfer and RT-to-RT transfer errors, message format error, and other error conditions. TABLE 26 shows the Message Monitor Block Status Word. The Data Block Pointer references the first word stored in the Monitor Data Stack (the first word following the Command Word) for the current message. The BU-61582 will then proceed to store the subsequent words from the message (possible second Command Word, Data Word(s), Status Word(s) into consecutive locations in the Monitor Data Stack).

The size of the Monitor Command Stack is programmable to 256, 1K, 4K, or 16K words. The Monitor Data Stack size is programmable to 512, 1K, 2K, 4K, 8K, 16K, 32K, or 64K words.

Monitor interrupts may be enabled for Monitor Command Stack Rollover, Monitor Data Stack Rollover, and/or End-of-Message conditions. In addition, in the Word Monitor mode there may be an interrupt enabled for a Monitor Trigger condition.

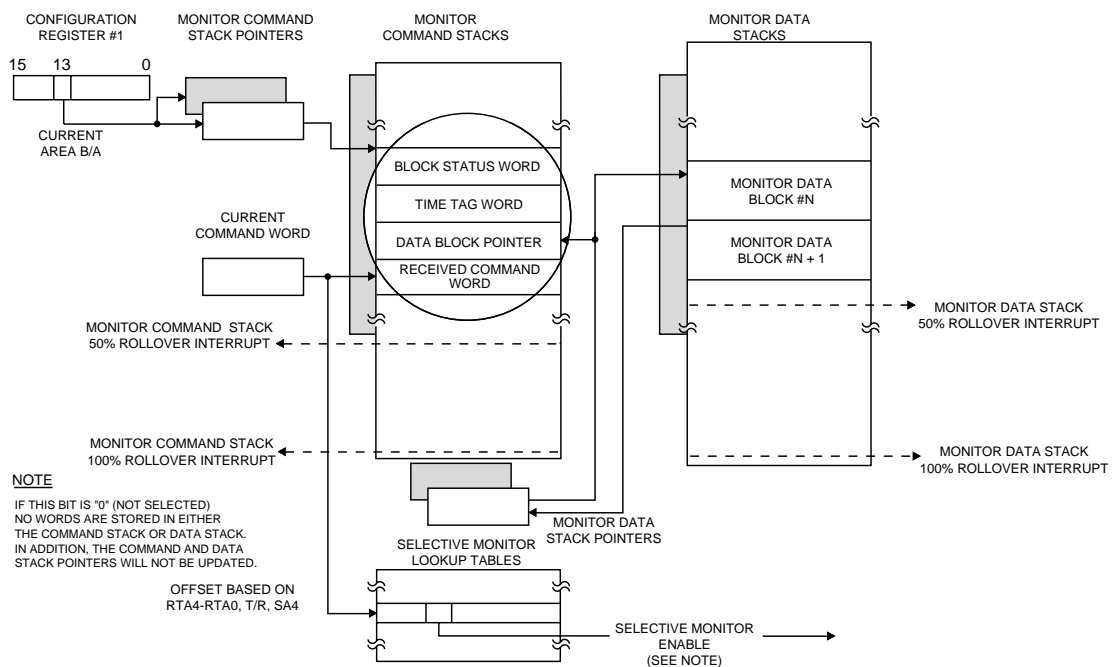

FIGURE 8. SELECTIVE MESSAGE MONITOR OPERATION

PROCESSOR AND MEMORY INTERFACE

The SP'ACE terminals provide much flexibility for interfacing to a host processor and optional external memory. FIGURE 1 shows that there are 14 control signals, 6 of which are dual purpose, for the processor/memory interface. FIGURES 9 through 14 illustrate six of the configurations that may be used for interfacing the BU-61582 to a host processor bus. The various possible configurations serve to reduce to an absolute minimum the amount of glue logic required to interface to 8-, 16-, and 32-bit processor buses. Also included are features to facilitate interfacing to processors that do not have a "wait state" type of handshake acknowledgment. Finally, the SP'ACE supports a reliable interface to an external dual port RAM. This type of interface minimizes the portion of the available processor bandwidth required to access the 1553 RAM.

The 16-bit buffered mode (FIGURE 9) is the most common configuration used. It provides a direct, shared RAM interface to a 16-bit or 32-bit microprocessor. In this mode, the SP'ACE's internal address and data buffers provide the necessary isolation between the host processor's address and data buses and the corresponding internal memory buses. In the buffered mode, the 1553 shared RAM address space limit is the BU-61582's 16K words of internal RAM. The 16-bit buffered mode provides a pair of pin-programmable options:

(1) The logic sense of the $\overline{RD}/\overline{WR}$ control input is selectable by the POLARITY_SEL input; for example, write when $\overline{RD}/\overline{WR}$ is low for Motorola 680X0 processors; write when $\overline{RD}/\overline{WR}$ is high for the Intel i960 series microprocessors.

(2) By strapping the input signal $\overline{ZERO\ WAIT}$ to logic "1", the SP'ACE terminals may interface to processors that have an acknowledge type of handshake input to accommodate hardware controlled wait states; most current processor chips have such an input. In this case, the BU-61582 will assert its \overline{READY} output low only after it has latched WRITE data internally or has presented READ data on D15-D0.

By strapping $\overline{ZERO\ WAIT}$ to logic "0", it is possible to easily interface the BU-61582 to processors that do not have an acknowledge type of handshake input. An example of such a processor is Analog Device's ADSP2101 DSP chip. In this configuration, the processor can clear its strobe output before the completion of access to the BU-61582 internal RAM or register. In this case, \overline{READY} goes high following the rising edge of \overline{STRBD} and will stay high until completion of the transfer. \overline{READY} will normally be low when $\overline{ZERO\ WAIT}$ is low.

Similar to the 16-bit buffered mode, the 16-bit transparent mode (FIGURE 10) supports a shared RAM interface to a host CPU. The transparent mode offers the advantage of allowing the buffer RAM size to be expanded to up to 64K words, using external

RAM. A disadvantage of the transparent mode is that it requires external address and data buffers to isolate the processor buses from the memory/BU-61582 buses.

A modified version of the transparent mode involves the use of dual port RAM, rather than conventional static RAM. Refer to FIGURE 11. This allows the host to access RAM very quickly, the only limitation being the access time of the dual port RAM. This configuration eliminates the BU-61582 arbitration delays for memory accesses. The worst case delay time occurs only during a simultaneous access by the host and the BU-61582 1553 logic to the same memory address. In general, this will occur very rarely and the SP'ACE limits the delay to approximately 250 ns.

FIGURE 12 illustrates the connections for the 16-bit Direct Memory Access (DMA) mode. In this configuration the host processor, rather than the SP'ACE terminal, arbitrates the use of the address and data buses. The arbitration involves the two DMA output signals Request (\overline{DTGRT}) and Acknowledge (\overline{DTACK}) and the input signal Grant (\overline{DTGRT}). The DMA interface allows the SP'ACE components to interface to large amounts of system RAM while eliminating the need for external buffers. For system address spaces larger than 64K words, it is necessary for the host processor to provide a page register for the upper address bits (above A15) when the BU-61582 accesses the RAM (while asserting \overline{DTACK} low).

The internal RAM is accessible through the standard SP'ACE interface (\overline{SELECT} , \overline{STRBD} , \overline{READYD} , etc). The host CPU may access external RAM by the SP'ACE's arbitration logic and output control signals, as illustrated in FIGURE 12. Alternatively, control of the RAM may be shared by both the host processor and the SP'ACE, as illustrated in FIGURE 13. The latter requires the use of external logic, but allows the processor to access the RAM directly at the full access speed of the RAM, rather than waiting for the SP'ACE handshake acknowledge output \overline{READY} .

FIGURE 14 illustrates the 8-bit buffered mode. This interface allows a direct connection to 8-bit microprocessors and 8-bit microcontrollers. As in the 16-bit buffered configuration, the buffer RAM limit is the BU-61582's 16K words of internal RAM. In the 8-bit mode, the host CPU accesses the BU-61582's internal registers and RAM by a pair of 8-bit registers embedded in the SP'ACE interface. The 8-bit interface may be further configured by three strappable inputs: $\overline{ZEROWAIT}$ POLARITY_SEL, and TRIGGER_SEL. By connecting $\overline{ZEROWAIT}$ to logic "0", the BU-61582 may be interfaced with minimal "glue" logic to 8-bit microcontrollers, such as the Intel 8051 series, that do not have an Acknowledge type of handshake input. The programmable inputs POLARITY_SEL and TRIGGER_SEL allow the BU-61582 to accommodate the different byte ordering conventions and "A0" logic sense utilized by different 8-bit processor families.

PROCESSOR INTERFACE TIMING

FIGURES 16 and 17 illustrate the timing for the host processor to access the SP'ACE's internal RAM or registers in the 16-bit, nonzero wait buffered mode. FIGURE 16 illustrates the 16-bit buffered, nonzero wait state mode read cycle timing while FIGURE 17 shows the 16-bit, buffered, nonzero wait state mode write cycle timing.

During a CPU transfer cycle, the signals $\overline{\text{STRB}}$ and $\overline{\text{SELECT}}$ must be sampled low on the rising edge of the system clock to request access to the BU-61582's internal shared RAM. The transfer will begin on the first rising system clock edge when $\overline{\text{SELECT}}$ and $\overline{\text{STRBD}}$ are low and the 1553 protocol/memory management unit is not accessing the internal RAM. The falling edge of the output signal $\overline{\text{IOEN}}$ indicates the start of the transfer. The SP'ACE latches the signals $\text{MEM}/\overline{\text{REG}}$ and $\text{RD}/\overline{\text{WR}}$ internally on the first falling clock edge after the start of the transfer cycle. The address inputs latch internally on the first rising clock edge after the signal $\overline{\text{IOEN}}$ goes low. Note that the address lines may be latched at any time using the ADDR_LAT input signal.

The output signal $\overline{\text{READYD}}$ will be asserted low on the third (or 7th if it's an internal read) rising system clock edge after $\overline{\text{IOEN}}$ goes low. The assertion of $\overline{\text{READYD}}$ low indicates to the host processor that read data is available on the parallel data bus, or that write data has been stored. At this time, the CPU should bring the signal $\overline{\text{STRBD}}$ high, completing the transfer cycle.

ADDRESS LATCH TIMING

FIGURE 15 illustrates the operation and timing of the address input latches for the buffered interface mode. In the transparent mode, the address buffers are always transparent. Since the transparent mode requires the use of external buffers, external address latches would be required to demultiplex a multiplexed address bus. In the buffered mode however, the SP'ACE's internal address latches may be used to perform the demultiplexing function.

The ADDR_LAT input signal controls address latch operation. When ADDR_LAT is high, the outputs of the latch (which drive

the SP'ACE's internal memory bus) track the state of address inputs A15 - A00. When low, the internal memory bus remains latched at the state of A15 - A00 just prior to the falling edge of ADDR_LAT.

MISCELLANEOUS SELF-TEST

The BU-61582 products incorporate several self-test features. These features include an on-line wraparound self-test for all messages in BC and RT modes, an off-line wraparound self-test for BC mode, and several other internal self-test features.

The BC/RT on-line loop test involves a wraparound test of the encoder/decoder and transceiver. The BC off-line self-test involves the encoder/decoder, but not the transceiver. These tests entail checking the received version of every transmitted word for validity (sync, encoding, bit count, parity) and checking the received version of the last transmitted word for a bit-by-bit comparison with the encoded word. The loopback test also fails if there is a timeout of the internal transmitter watchdog timer. A failure of the loop test results in setting a bit in the message's Block Status Word and, if enabled, will result in an interrupt request. With appropriate host processor software, the BC off-line test is able to exercise the parallel and serial data paths, encoder, decoder, and a substantial portion of the BC protocol and memory management logic.

There are additional built-in self-test features, involving the use of three configuration register bits and the eight test registers. This allows a test of approximately 99% of the J-Rad chip's internal logic. These tests include an encoder test, a decoder test, a register test, a protocol test, and a test of the fail-safe (transmitter timeout) timer.

There is also a test mode. In the test mode, the host processor can emulate arbitrary activity on the 1553 buses by writing to a pair of test registers. The test mode can be operated in conjunction with the Word Monitor mode to facilitate end-to-end self-tests.

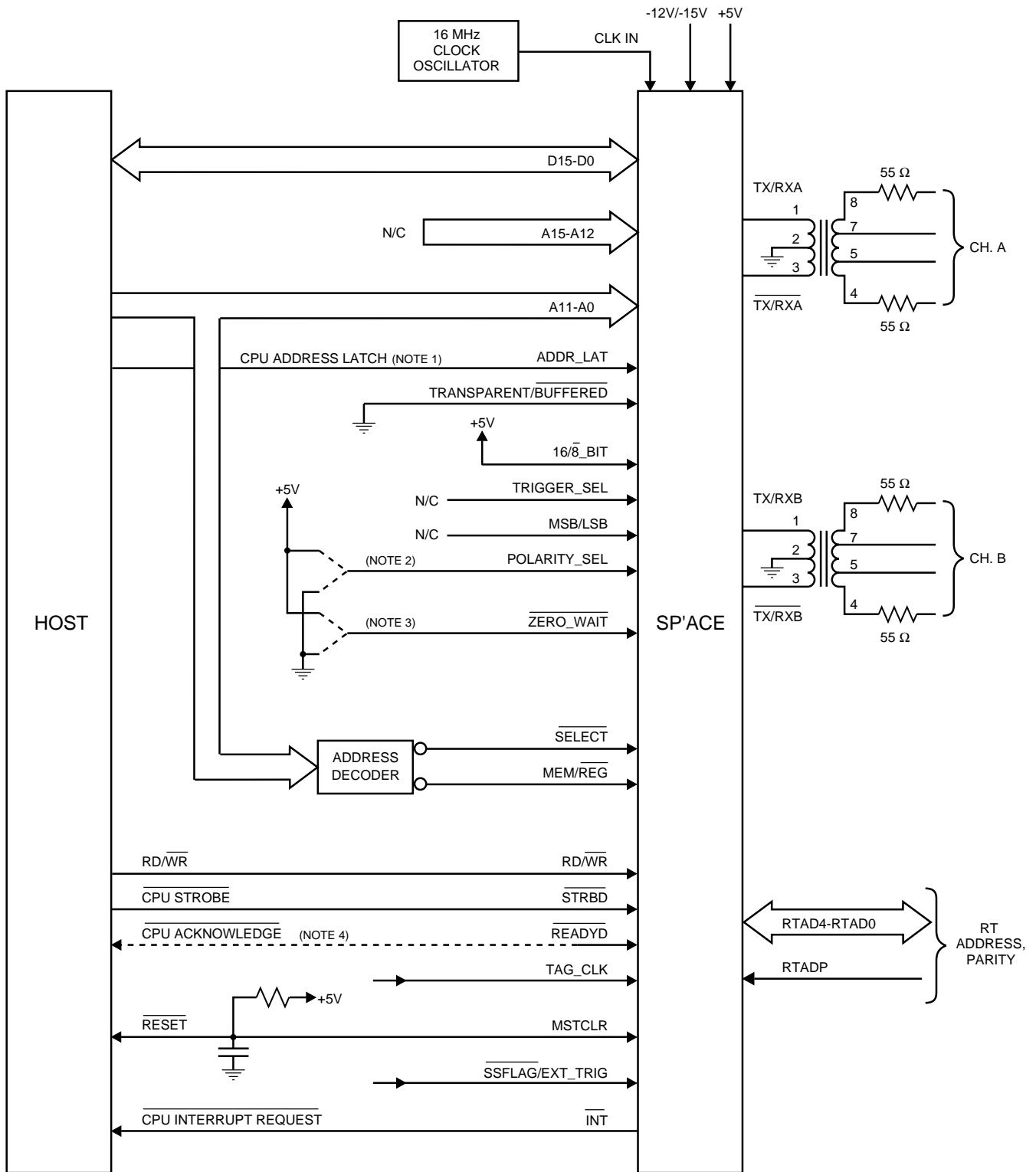

NOTES:

1. CPU ADDRESS LATCH SIGNAL PROVIDED BY PROCESSORS WITH MULTIPLEXED ADDRESS/DATA BUSES.
2. IF POLARITY_SEL = "1", RD/WR IS HIGH TO READ, LOW TO WRITE.
IF POLARITY_SEL = "0", RD/WR IS LOW TO READ, HIGH TO WRITE.

3. ZERO_WAIT SHOULD BE STRAPPED TO LOGIC "1" FOR NON-ZERO WAIT INTERFACE AND TO LOGIC "0" FOR ZERO WAIT INTERFACE.
4. CPU ACKNOWLEDGE PROCESSOR INPUT ONLY FOR NON-ZERO WAIT TYPE OF INTERFACE.

FIGURE 9. 16-BIT BUFFERED MODE

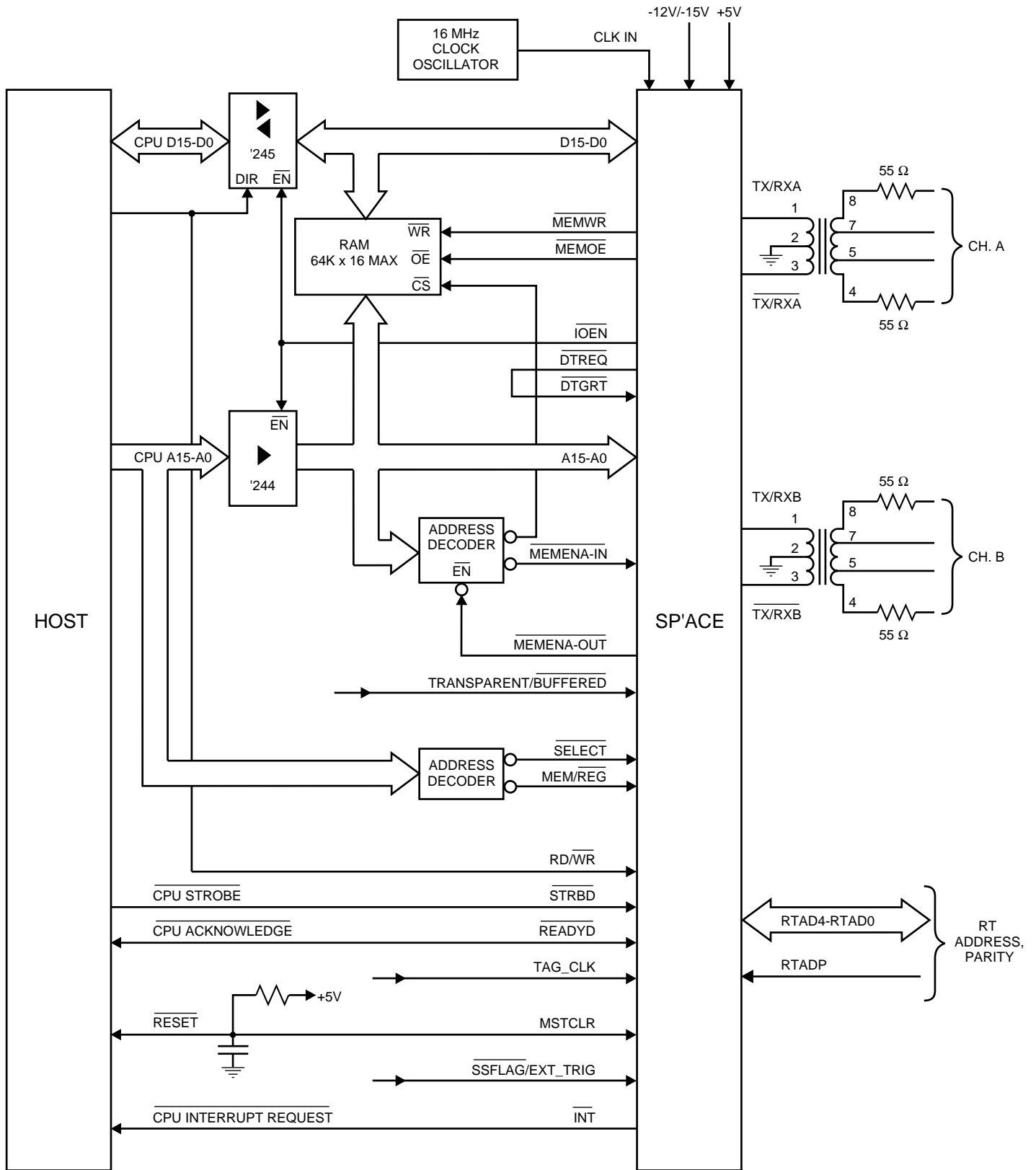

FIGURE 10. 16-BIT TRANSPARENT MODE

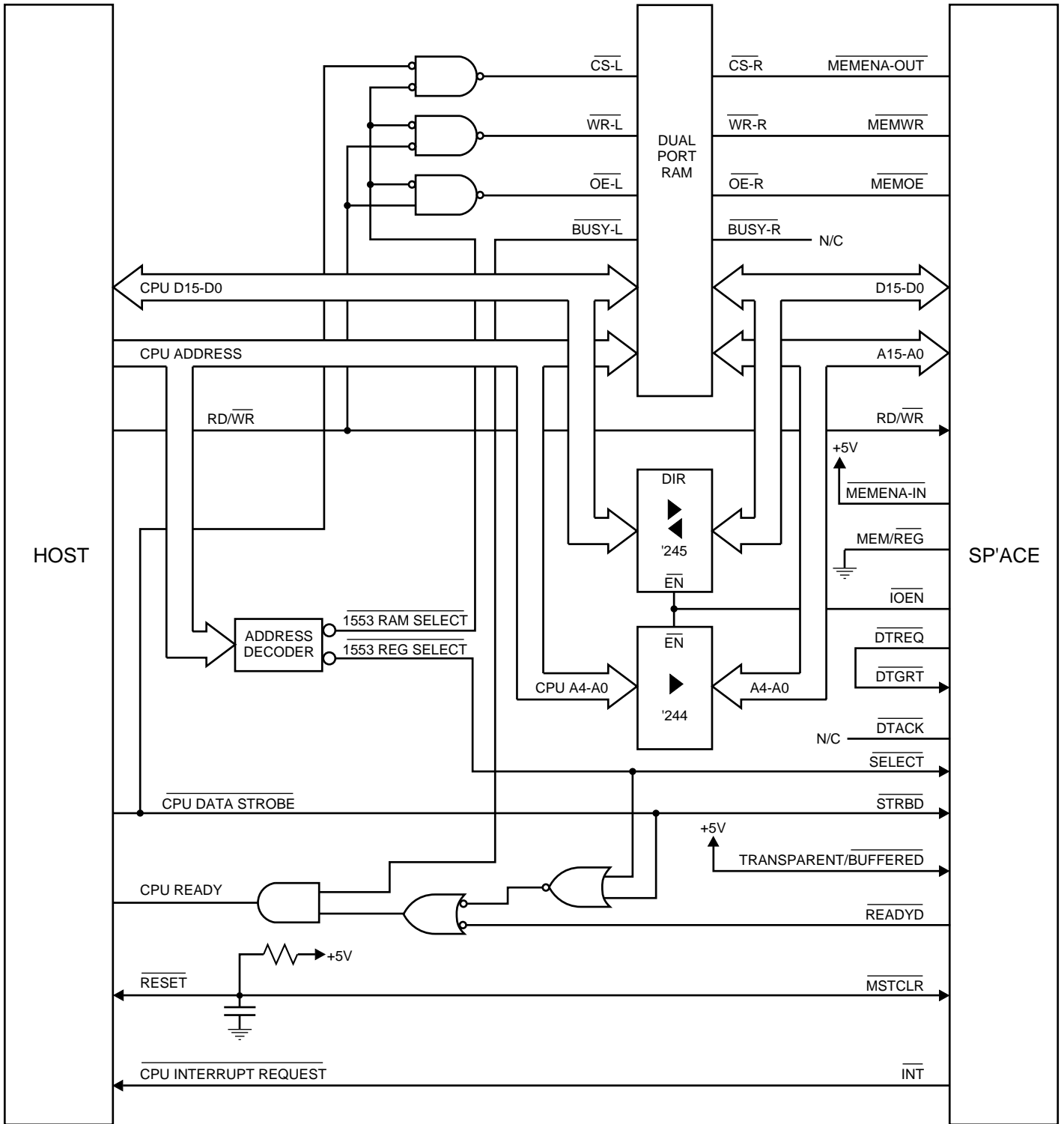

FIGURE 11. 16-BIT TRANSPARENT MODE USING DUAL PORT RAM

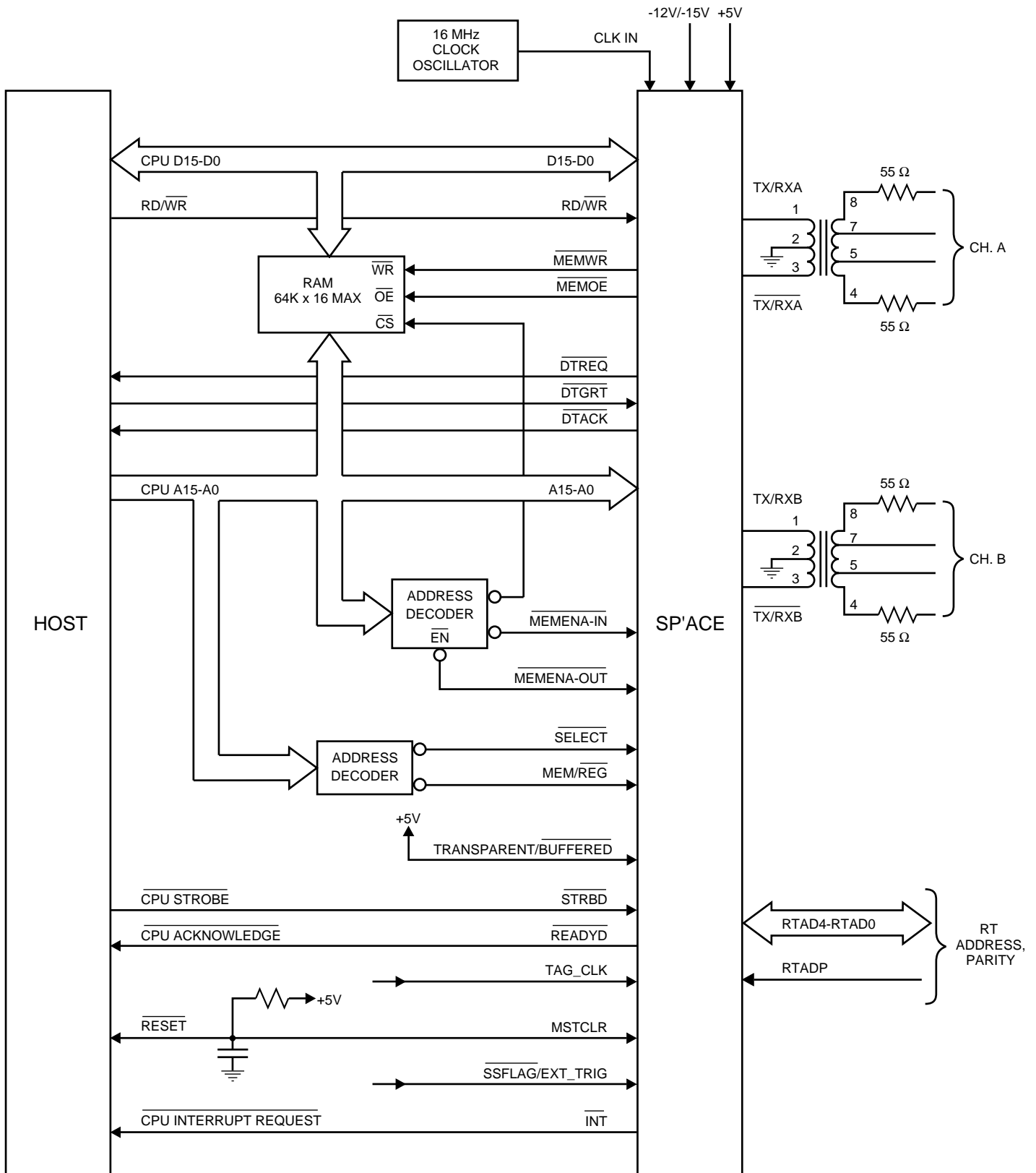

FIGURE 12. 16-BIT DIRECT MEMORY ACCESS (DMA) MODE

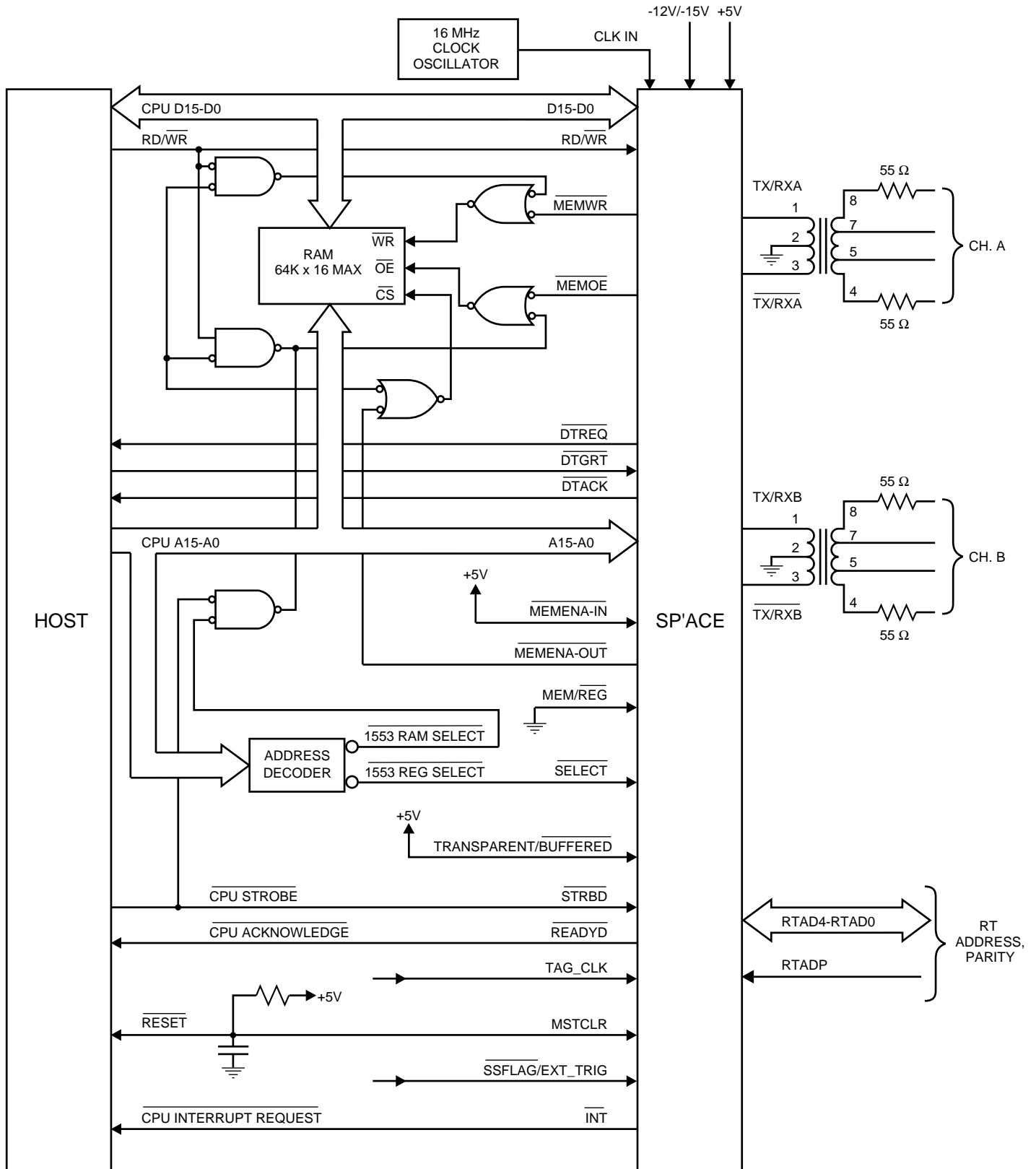
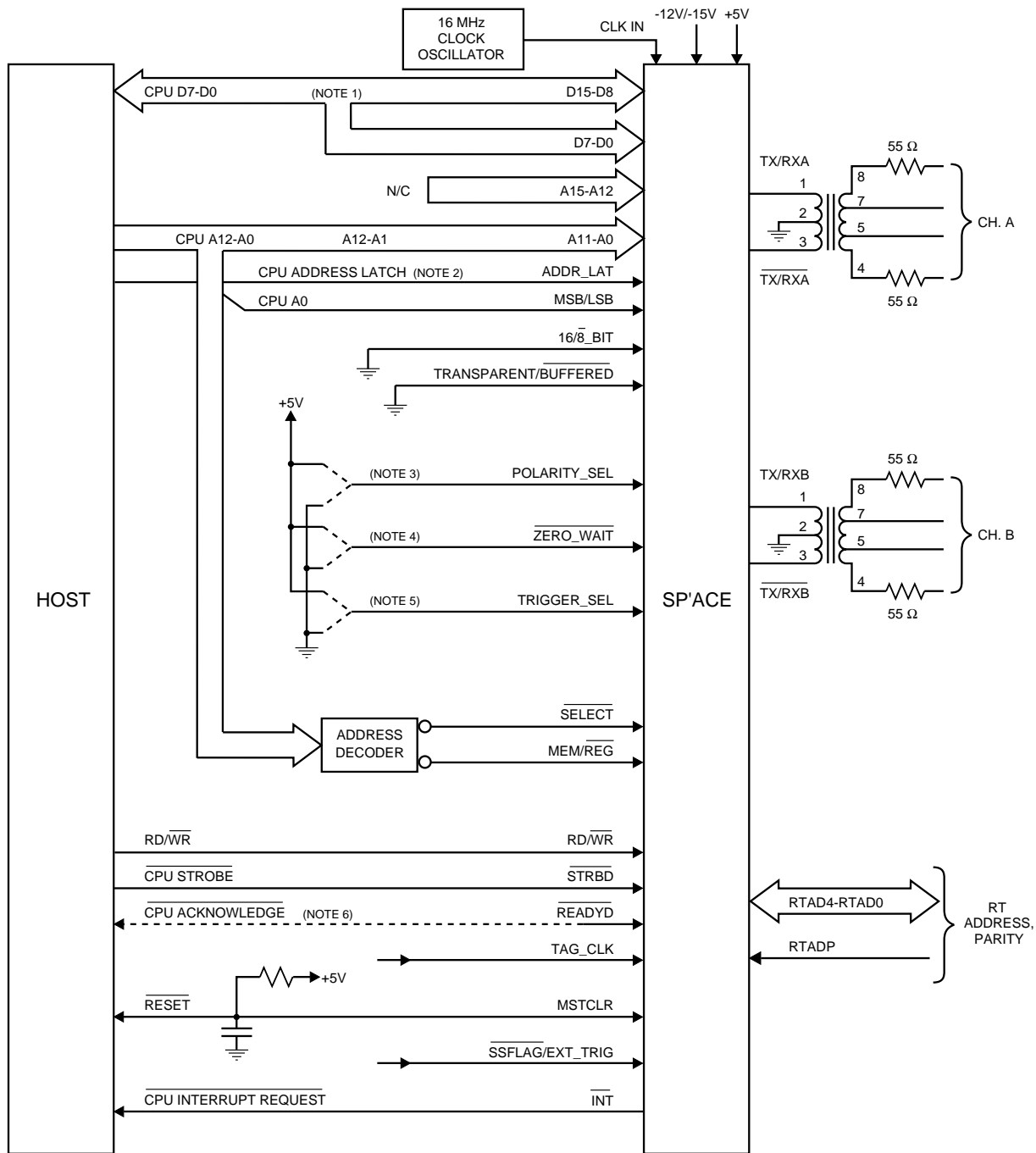

FIGURE 13. 16-BIT DMA MODE WITH EXTERNAL LOGIC TO REDUCE PROCESSOR ACCESS TIME TO EXTERNAL RAM



NOTES:

1. CPU D7-D0 CONNECTS TO BOTH D15-D8 AND D7-D0.
2. CPU ADDRESS LATCH SIGNAL PROVIDED BY PROCESSORS WITH MULTIPLEXED ADDRESS/DATA BUFFERS.
3. IF POLARITY_SEL = "1", THEN MSB/LSB SELECTS THE MOST SIGNIFICANT BYTE WHEN LOW, AND THE LEAST SIGNIFICANT BYTE WHEN HIGH. IF POLARITY_SEL = "0", THEN MSB/LSB SELECTS THE LEAST SIGNIFICANT BYTE WHEN LOW, AND THE MOST SIGNIFICANT BYTE WHEN HIGH.
4. ZERO_WAIT SHOULD BE STRAPPED TO LOGIC "1" FOR NON-ZERO WAIT INTERFACE AND TO LOGIC "0" FOR ZERO WAIT INTERFACE.
5. OPERATION OF TRIGGER_SELECT INPUT IS AS FOLLOWS: FOR NON-ZERO WAIT INTERFACE (ZERO_WAIT = "1"): IF TRIGGER_SEL = "1", THEN INTERNAL 16-BIT TRANSFERS ARE TRIGGERED BY THE MOST SIGNIFICANT BYTE TRANSFER READ ACCESSES AND BY THE LEAST SIGNIFICANT BYTE TRANSFER FOR WRITE ACCESSES. IF TRIGGER_SEL = "0", THEN INTERNAL 16-BIT TRANSFERS ARE TRIGGERED BY THE LEAST SIGNIFICANT BYTE TRANSFER FOR READ ACCESSES AND BY THE MOST SIGNIFICANT BYTE TRANSFER FOR WRITE ACCESSES. FOR ZERO WAIT INTERFACE (ZERO_WAIT = "0"): IF TRIGGER_SEL = "1", THEN INTERNAL 16-BIT TRANSFERS ARE TRIGGERED BY THE LEAST SIGNIFICANT BYTE TRANSFER, FOR BOTH READ AND WRITE ACCESSES. IF TRIGGER_SEL = "0", THEN INTERNAL 16-BIT TRANSFERS ARE TRIGGERED BY THE MOST SIGNIFICANT BYTE TRANSFER, FOR BOTH READ AND WRITE ACCESSES.
6. CPU ACKNOWLEDGE PROCESSOR INPUT ONLY FOR NON-ZERO WAIT TYPE OF INTERFACE.

FIGURE 14. 8-BIT BUFFERED MODE

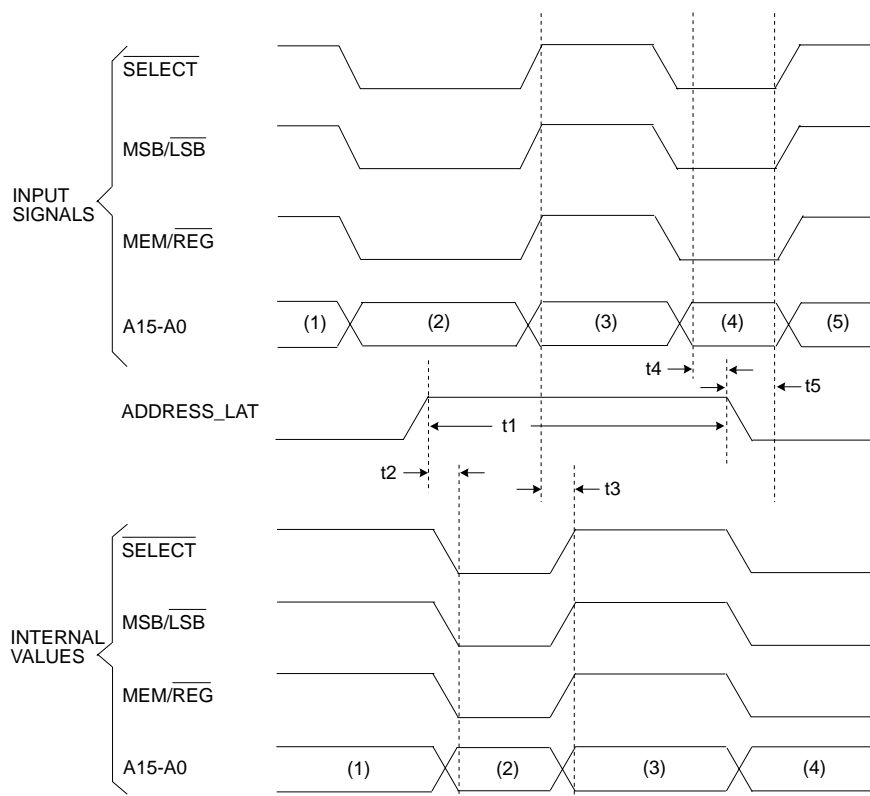

Notes for FIGURE 15 and associated table.

1. Applicable to buffered mode only. Address $\overline{\text{SELECT}}$ AND $\overline{\text{MEM/REG}}$ latches are always transparent in the transparent mode of operation.
2. Latches are transparent when ADDR_LAT is high. Internal values do not update when ADDR_LAT is low.
3. MSB/LSB input signal is applicable to 8-bit mode only (16/8 input = logic "0"). MSB/LSB input is a "don't care" for 16-bit operation.

TABLE FOR FIGURE 15. ADDRESS LATCH TIMING						
REF	DESCRIPTION	MIN	TYP	MAX	UNITS	
t1	ADDR_LAT pulse width	20			ns	
t2	ADDR_LAT high delay to internal signals valid			10	ns	
t3	Propagation delay from external input signals to internal signals valid			10	ns	
t4	Input setup time prior to falling edge of ADDR_LAT	10			ns	
t5	Input hold time following falling edge of ADDR_LAT	20			ns	

FIGURE 15. ADDRESS LATCH TIMING

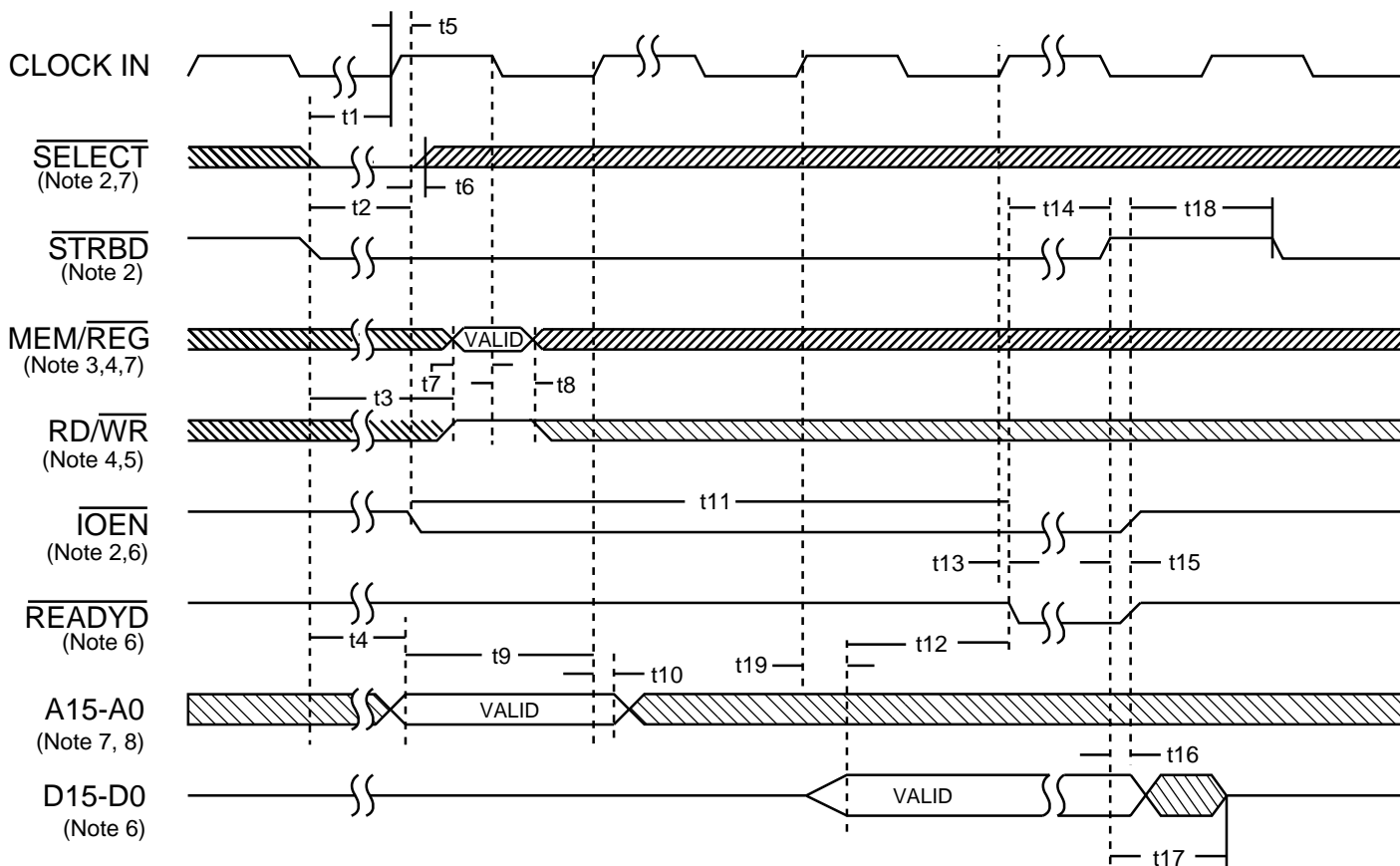

FIGURE 16. CPU READING RAM (SHOWN FOR 16-BIT, BUFFERED, NONZERO WAIT MODE)

TABLE FOR FIGURE 16. CPU READING RAM OR REGISTERS (SHOWN FOR 16-BIT, BUFFERED, NONZERO WAIT MODE)

REF	DESCRIPTION	MIN	TYP	MAX	UNITS	NOTE REFERENCE
t1	$\overline{\text{SELECT}}$ and $\overline{\text{STRBD}}$ low setup time prior to clock rising edge	15			ns	note 2
t2	$\overline{\text{SELECT}}$ and $\overline{\text{STRBD}}$ low delay to $\overline{\text{IOEN}}$ low (uncontended access @ 16 MHz)			107.5	ns	notes 2, 6
t2	$\overline{\text{SELECT}}$ and $\overline{\text{STRBD}}$ low delay to $\overline{\text{IOEN}}$ low (contended access @ 16 MHz)			5.24	μs	notes 2, 6
t2	$\overline{\text{SELECT}}$ and $\overline{\text{STRBD}}$ low delay to $\overline{\text{IOEN}}$ low (uncontended access @ 12 MHz)			128.3	ns	notes 2, 6
t2	$\overline{\text{SELECT}}$ and $\overline{\text{STRBD}}$ low delay to $\overline{\text{IOEN}}$ low (contended access @ 12 MHz)			6.97	μs	notes 2, 6
t3	$\text{MEM}/\overline{\text{REG}}$, $\text{RD}/\overline{\text{WR}}$ setup time following $\overline{\text{SELECT}}$ and $\overline{\text{STRBD}}$ low (@ 16 MHz)			10	ns	
t3	$\text{MEM}/\overline{\text{REG}}$, $\text{RD}/\overline{\text{WR}}$ setup time following $\overline{\text{SELECT}}$ and $\overline{\text{STRBD}}$ low (@ 12 MHz)			20	ns	
t4	Address valid setup time following $\overline{\text{SELECT}}$ and $\overline{\text{STRBD}}$ low (@ 16 MHz)			50	ns	
t4	Address valid setup time following $\overline{\text{SELECT}}$ and $\overline{\text{STRBD}}$ low (@ 12 MHz)			70	ns	
t5	CLOCK IN rising edge delay to $\overline{\text{IOEN}}$ falling edge			30	ns	
t6	$\overline{\text{SELECT}}$ hold time following $\overline{\text{IOEN}}$ falling	0			ns	note 2
t7	$\text{MEM}/\overline{\text{REG}}$, $\text{RD}/\overline{\text{WR}}$ setup time prior to CLOCK IN falling edge	10			ns	notes 3, 4, 5
t8	$\text{MEM}/\overline{\text{REG}}$, $\text{RD}/\overline{\text{WR}}$ hold time prior to CLOCK IN falling edge	25			ns	notes 3, 4, 5
t9	Address valid setup time prior to CLOCK IN rising edge	10			ns	
t10	Address hold time following CLOCK IN rising edge	25			ns	note 9
t11	$\overline{\text{IOEN}}$ falling delay to $\overline{\text{READYD}}$ falling (reading RAM @ 16 MHz)	420	437.5	455	ns	note 6
t11	$\overline{\text{IOEN}}$ falling delay to $\overline{\text{READYD}}$ falling (reading RAM @ 12 MHz)	565	583.3	600	ns	note 6
t11	$\overline{\text{IOEN}}$ falling delay to $\overline{\text{READYD}}$ falling (reading registers @ 16 MHz)	170	187.5	205	ns	note 6
t11	$\overline{\text{IOEN}}$ falling delay to $\overline{\text{READYD}}$ falling (reading registers @ 12 MHz)	230	250	265	ns	note 6
t12	Output Data valid prior to $\overline{\text{READYD}}$ falling (@ 16 MHz)	33			ns	note 6
t12	Output Data valid prior to $\overline{\text{READYD}}$ falling (@ 12 MHz)	54			ns	note 6
t13	CLOCK IN rising edge delay to $\overline{\text{READYD}}$ falling			0	ns	note 6
t14	$\overline{\text{READYD}}$ falling to $\overline{\text{STRBD}}$ rising release time			∞	ns	
t15	$\overline{\text{STRBD}}$ rising edge delay to $\overline{\text{IOEN}}$ rising edge and $\overline{\text{READYD}}$ rising edge			40	ns	note 6
t16	Output Data hold time following $\overline{\text{STRBD}}$ rising edge	0			ns	
t17	$\overline{\text{STRBD}}$ rising delay to output Data tri-state			40	ns	
t18	$\overline{\text{STRBD}}$ high hold time from $\overline{\text{READYD}}$ rising	0			ns	

Notes for FIGURE 16 and associated table.

- For the 16-bit buffered configuration, the inputs TRIGGER_SEL and MSB/LSB may be connected to +5 V or GND. For the nonzero wait interface ZEROWAIT, must be connected to logic "1".
- $\overline{\text{SELECT}}$ and $\overline{\text{STRBD}}$ may be tied together. $\overline{\text{IOEN}}$ goes low on the first rising CLK edge when $\overline{\text{SELECT}}$ $\overline{\text{STRBD}}$ is sampled low (satisfying t2) and the BU-61582's protocol/memory management logic is not accessing the internal RAM. When this occurs, $\overline{\text{IOEN}}$ goes low, starting the transfer cycle. After $\overline{\text{IOEN}}$ goes low, $\overline{\text{SELECT}}$ may be released high.
- $\text{MEM}/\overline{\text{REG}}$ must be presented high for memory access, low for register access.
- $\text{MEM}/\overline{\text{REG}}$ and $\text{RD}/\overline{\text{WR}}$ are buffered transparently until the first falling edge of CLK after $\overline{\text{IOEN}}$ goes low. After this CLK edge, $\text{MEM}/\overline{\text{REG}}$ and $\text{RD}/\overline{\text{WR}}$ become latched internally.
- The logic sense for $\text{RD}/\overline{\text{WR}}$ in the diagram assumes that POLARITY_SEL is connected to logic "1". If POLARITY_SEL is connected

to logic "0", $\text{RD}/\overline{\text{WR}}$ must be asserted low to read.

- The timing for $\overline{\text{IOEN}}$, $\overline{\text{READYD}}$ and D15-D0 assumes a 50 pf load. For loading above 50 pf, the validity of $\overline{\text{IOEN}}$, $\overline{\text{READYD}}$, and D15-D0 is delayed by an additional 0.14 ns/pf typ, 0.28 ns/pf max.
- Timing for A15-A0 assumes ADDR-LAT is connected to logic "1". Refer to Address Latch timing for additional details
- Internal RAM is accessed by A13 through A0. Registers are accessed by A4 through A0.
- The address bus A15-A0 is internally buffered transparently until the first rising edge of CLK after $\overline{\text{IOEN}}$ goes low. After this CLK edge, A15-A0 become latched internally.

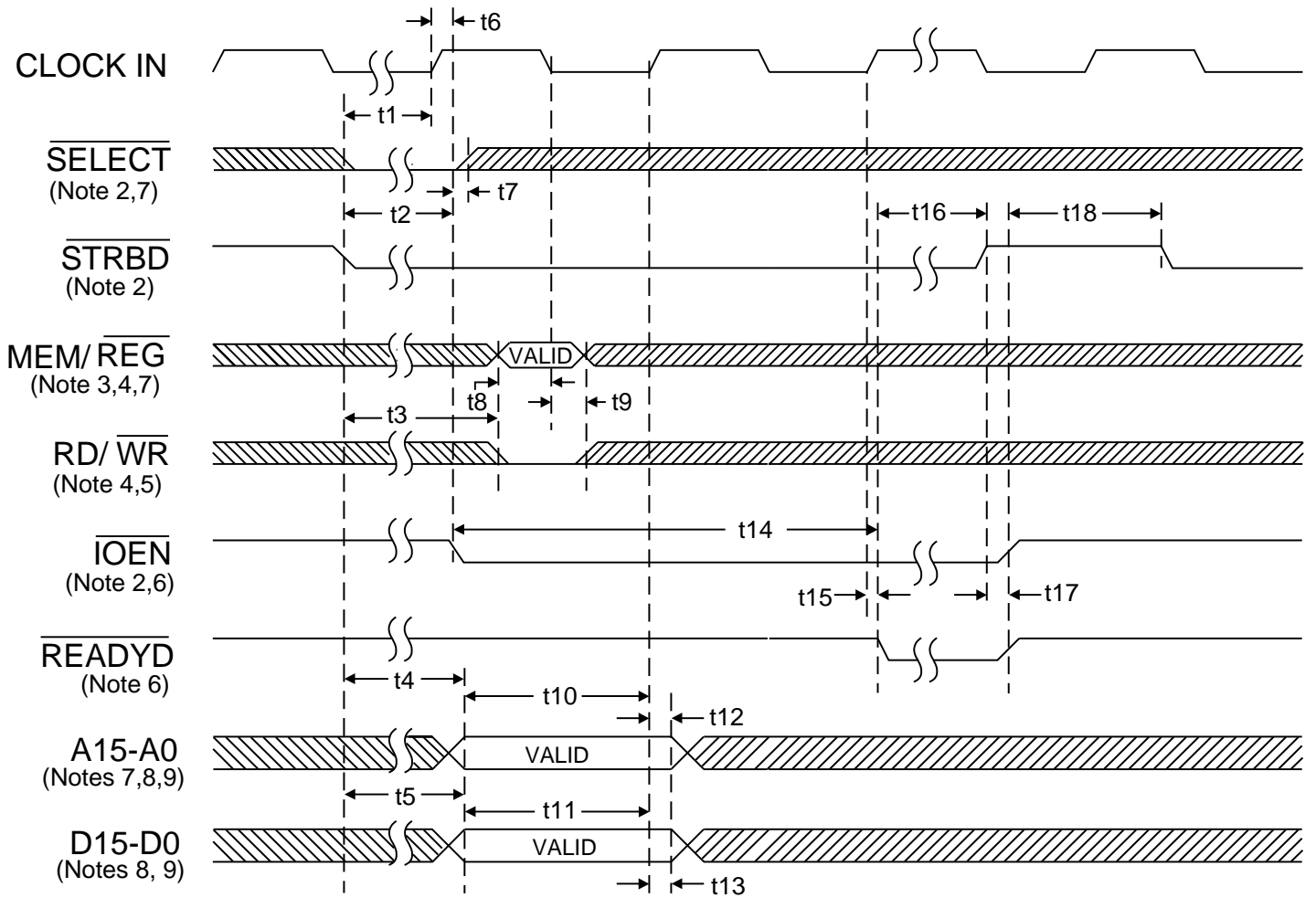

FIGURE 17. CPU WRITING RAM (SHOWN FOR 16-BIT, BUFFERED, NONZERO WAIT MODE)

TABLE FOR FIGURE 17. CPU WRITING RAM OR REGISTERS (SHOWN FOR 16-BIT, BUFFERED, NONZERO WAIT MODE)

REF	DESCRIPTION	MIN	TYP	MAX	UNITS	NOTE REFERENCE
t1	$\overline{\text{SELECT}}$ and $\overline{\text{STRBD}}$ low setup time prior to clock rising edge	15			ns	note 2
t2	$\overline{\text{SELECT}}$ and $\overline{\text{STRBD}}$ low delay to $\overline{\text{IOEN}}$ low (uncontended access @ 16 MHz)			107.5	ns	notes 2, 6
t2	$\overline{\text{SELECT}}$ and $\overline{\text{STRBD}}$ low delay to $\overline{\text{IOEN}}$ low (contended access @ 16 MHz)			5.24	μs	notes 2, 6
t2	$\overline{\text{SELECT}}$ and $\overline{\text{STRBD}}$ low delay to $\overline{\text{IOEN}}$ low (uncontended access @ 12 MHz)			128.3	ns	notes 2, 6
t2	$\overline{\text{SELECT}}$ and $\overline{\text{STRBD}}$ low delay to $\overline{\text{IOEN}}$ low (contended access @ 12 MHz)			6.97	μs	notes 2, 6
t3	MEM/REG, RD/WR setup time following $\overline{\text{SELECT}}$ and $\overline{\text{STRBD}}$ low(@ 16 MHz)			10	ns	
t3	MEM/REG, RD/WR setup time following $\overline{\text{SELECT}}$ and $\overline{\text{STRBD}}$ low(@ 12 MHz)			20	ns	
t4	Address valid setup time following $\overline{\text{SELECT}}$ and $\overline{\text{STRBD}}$ low (@ 16 MHz)			50	ns	
t4	Address valid setup time following $\overline{\text{SELECT}}$ and $\overline{\text{STRBD}}$ low (@ 12 MHz)			70	ns	
t5	CLOCK IN rising edge delay to $\overline{\text{IOEN}}$ falling edge			30	ns	
t6	$\overline{\text{SELECT}}$ hold time following $\overline{\text{IOEN}}$ falling	0			ns	note 2
t7	MEM/REG, RD/WR setup time prior to CLOCK IN falling edge	10			ns	notes 3, 4, 5
t8	MEM/REG, RD/WR hold time prior to CLOCK IN falling edge	25			ns	notes 3, 4, 5
t9	Address valid setup time prior to CLOCK IN rising edge	10			ns	
t10	Address hold time following CLOCK IN rising edge	25			ns	note 9
t11	$\overline{\text{IOEN}}$ falling delay to $\overline{\text{READYD}}$ falling (reading RAM @ 16 MHz)	420	437.5	455	ns	note 6
t11	$\overline{\text{IOEN}}$ falling delay to $\overline{\text{READYD}}$ falling (reading RAM @ 12 MHz)	565	583.3	600	ns	note 6
t11	$\overline{\text{IOEN}}$ falling delay to $\overline{\text{READYD}}$ falling (reading registers @ 16 MHz)	170	187.5	205	ns	note 6
t11	$\overline{\text{IOEN}}$ falling delay to $\overline{\text{READYD}}$ falling (reading registers @ 12 MHz)	230	250	265	ns	note 6
t12	Output Data valid prior to $\overline{\text{READYD}}$ falling (@ 16 MHz)	33			ns	note 6
t12	Output Data valid prior to $\overline{\text{READYD}}$ falling (@ 12 MHz)	54			ns	note 6
t13	CLOCK IN rising edge delay to $\overline{\text{READYD}}$ falling			0	ns	note 6
t14	$\overline{\text{READYD}}$ falling to $\overline{\text{STRBD}}$ rising release time			∞	ns	
t15	$\overline{\text{STRBD}}$ rising edge delay to $\overline{\text{IOEN}}$ rising edge and $\overline{\text{READYD}}$ rising edge			40	ns	note 6
t16	Output Data hold time following $\overline{\text{STRBD}}$ rising edge	0			ns	
t17	$\overline{\text{STRBD}}$ rising delay to output Data tri-state			40	ns	
t18	$\overline{\text{STRBD}}$ high hold time from $\overline{\text{READYD}}$ rising	0			ns	

Notes for FIGURE 17 and associated table.

- For the 16-bit buffered configuration, the inputs TRIGGER_SEL and MSB/LSB may be connected to +5 V or GND. For the nonzero wait interface, $\overline{\text{ZEROWAIT}}$ must be connected to logic "1."
- $\overline{\text{SELECT}}$ and $\overline{\text{STRBD}}$ may be tied together. $\overline{\text{IOEN}}$ goes low on the first rising CLK edge when $\overline{\text{SELECT}} \bullet \overline{\text{STRBD}}$ is sampled low (satisfying t2) and the BU-61582's protocol/memory management logic is not accessing the internal RAM. When this occurs, $\overline{\text{IOEN}}$ goes low, starting the transfer cycle. After $\overline{\text{IOEN}}$ goes low, $\overline{\text{SELECT}}$ may be released high.
- MEM/REG must be presented high for memory access, low for register access.
- MEM/REG and RD/WR are buffered transparently until the first falling edge of CLK after $\overline{\text{IOEN}}$ goes low. After this CLK edge, MEM/REG and RD/WR become latched internally.
- The logic sense for RD/WR in the diagram assumes that POLARITY_SEL is connected to logic "1". If POLARITY_SEL is connected to logic "0", RD/WR must be asserted low to read.
- The timing for $\overline{\text{IOEN}}$, $\overline{\text{READYD}}$ and D15-D0 assumes a 50 pf load. For loading above 50 pf, the validity of $\overline{\text{IOEN}}$, $\overline{\text{READYD}}$, and D15-D0 is delayed by an additional 0.14 ns/pf typ, 0.28 ns/pf max.
- Timing for A15-A0 assumes ADDR-LAT is connected to logic "1". Refer to Address Latch timing for additional details.

- Internal RAM is accessed by A13 through A0. Registers are accessed by A4 through A0.
- The address bus A15-A0 is internally buffered transparently until the first rising edge of CLK after $\overline{\text{IOEN}}$ goes low. After this CLK edge, A15-A0 become latched internally.

INTERFACE TO MIL-STD-1553 BUS

FIGURE 18 illustrates the interface from the various versions of the SP'ACE series terminals to a 1553 bus. The figure also indicates connections for both direct (short stub) and transformer (long stub) coupling, plus the peak-to-peak voltage levels that appear at various points (when transmitting).

TABLE 33 lists the characteristics of the required isolation transformers for the various SP'ACE terminals, the DDC and Beta Transformer Technology Corporation corresponding part number, and the MIL (DESC) drawing number (if applicable). Beta Transformer Technology is a direct subsidiary of DDC.

For both coupling configurations, the isolation transformer is the transformer that interfaces directly to the SP'ACE component. For the transformer (long stub) coupling configuration, the transformer that interfaces the stub to the bus is the coupling transformer. The turns ratio of the isolation transformer varies, depending upon the peak-to-peak output voltage of the specific SP'ACE terminal.

The transmitter voltage of each model of the BU-61582 varies directly as a function of the power supply voltage. The turns ratios of the respective transformers will yield a secondary voltage of approximately 28 volts peak-to-peak on the outer taps (used for direct coupling) and 20 volts peak-to-peak on the inner taps (used for stub coupling).

In accordance with MIL-STD-1553B, the turns ratio of the coupling transformer is 1.0 to 1.4. Both coupling configurations require an isolation resistor to be in series with each leg connecting to the 1553 bus; this protects the bus against short circuit conditions in the transformers, stubs, or terminal components.

TABLE 33. ISOLATION TRANSFORMER GUIDE				
SP'ACE PART NUMBER	TURNS RATIO		RECOMMENDED XFORMER	
	DIRECT COUPLED	XFORMER COUPLED	PLUG-IN	SURFACE MOUNT
BU-61582X1	1.41:1	2:1	BUS-25679, B-2203, M21038/27-02	B-2387 M21038/27-12, M21038/27-17 LPB-5002 LPB-5009 LPB-6002 LPB-6009
BU-61582X2	1.20:1	1:0.6	BUS-29854	LPB-5001 LPB-5008 LPB-6001 LPB-6008
	1.25:1 (Note 5)		B-2204, M21038/27-03	B-2388 M21038/27-13, B-2334, M21038/27-18

Notes for TABLE 33 and FIGURE 18:

- (1) Shown for one of two redundant buses that interface to the BU-61582.
- (2) Transmitted voltage level on 1553 bus is 6 Vp-p min, 7 Vp-p nominal, 9 Vp-p max.
- (3) Required tolerance on isolation resistors is 2%. Instantaneous power dissipation (when transmitting) is approximately 0.5 W (typ), 0.8 W (max).
- (4) Transformer pin numbering is correct for the DDC (e.g., BUS-25679) transformers. For the Beta transformers (e.g., B-2203) or the QPL-21038-31 transformers (e.g., M21038/27-02), the winding sense and turns ratio are mechanically the same, but with reversed pin numbering; therefore, it is necessary to reverse pins 8 and 4 or pins 7 and 5 for the Beta or QPL transformers (Note: DDC transformer part numbers begin with a BUS- prefix, while Beta transformer part numbers begin with a B- prefix).
- (5) The B-2204, B-2388, and B-2344 transformers have a slightly different turns ratio on the direct coupled taps than the turns ratio of the BUS-29854 direct coupled taps. They do, however, have the same transformer coupled ratio. For transformer coupled applications, either transformer may be used. The transceiver in the BU-61582 was designed to work with a 1:0.83 ratio for direct coupled applications. For direct coupled applications, the 1.20:1 turns ratio is recommended, but the 1.25:1 may be used. The 1.25:1 turns ratio will result in a slightly lower transmitter amplitude. (Approximately 3.6% lower) and a slight shift in the SP'ACE's receiver threshold.

TRANSFORMER CONSIDERATIONS FOR BU-61582X3 (+5V ONLY VERSIONS)

In selecting isolation transformers to be used for the BU-61582X3 (+5V only) versions, there is a limitation on the maximum amount of leakage inductance. If this limit is exceeded, the transmitter rise and fall times may increase, possibly causing the bus amplitude to fall below the minimum level required by MIL-STD-1553. In addition, an excessive leakage imbalance may result in a transformer dynamic offset that exceeds 1553 specifications.

The maximum allowable leakage inductance is 6.0 μH, and is measured as follows:

The side of the transformer that connects to the Hybrid is defined as the “primary” winding. If one side of the primary is shorted to the primary center-tap, the inductance should be measured across the “secondary” (stub side) winding. This inductance must

be less than 6.0 μH. Similarly, if the other side of the primary is shorted to the primary center-tap, the inductance measured across the “secondary” (stub side) winding must also be less than 6.0 μH.

The difference between these two measurements is the “differential” leakage inductance. This value must be less than 1.0 μH.

Beta Transformer Technology Corporation (BTTC), a subsidiary of DDC, manufactures transformers in a variety of mechanical configurations with the required turns ratios of 1:2.5 direct coupled, and 1:1.79 transformer coupled. Table 34 provides a listing of many of these transformers. For further information, contact BTTC at 631-244-7393 or at www.btcc-beta.com.

TABLE 34. BTTC TRANSFORMERS FOR USE WITH BU-61582X3/X6	
TRANSFORMER CONFIGURATION	BTTC PART NO.
Single epoxy transformer, through-hole, 0.625" X 0.625", 0.250" max height	B-3067 B-3226
Single epoxy transformer, through-hole, 0.625" X 0.625", 0.220" max height May be used with BU-65142X4 versions.	B-3818
Single epoxy transformer, flat pack, 0.625" X 0.625", 0.275" max height	B-3231
Single epoxy transformer, surface mount, 0.625" X 0.625", 0.275" max height	B-3227
Single epoxy transformer, surface mount, hi-temp solder, 0.625" X 0.625", 0.220" max height. May be used with BU-65142X4 versions.	B-3819
Single epoxy transformer, flat pack, 0.625" X 0.625", 0.150" max height	LPB-5014
Single epoxy transformer, surface mount, 0.625" X 0.625", 0.150" max height	LPB-5015
Single epoxy transformer, through hole, transformer coupled only, 0.500" X 0.350", 0.250" max height.	B-3229
Dual epoxy transformer, twin stacked, 0.625" X 0.625", 0.280" max height	TST-9007
Dual epoxy transformer, twin stacked, surface mount, 0.625" X 0.625", 0.280" max height	TST-9017
Dual epoxy transformer, twin stacked, flat pack, 0.625" X 0.625", 0.280" max height	TST-9027
Dual epoxy transformer, side by side, through-hole, 0.930" X 0.630", 0.155" max height	B-3300
Dual epoxy transformer, side by side, flat pack, 0.930" X 0.630", 0.155" max height	B-3261
Dual epoxy transformer, side by side, surface mount, 0.930" X 0.630", 0.155" max height	B-3310
Dual epoxy transformer, side by side, surface mount, 1.410" X 0.750", 0.130" max height	DLP-7115 (see note 1)
Single metal transformer, hermetically sealed, flat pack, 0.630" X 0.630", 0.175" max height	HLP-6014
Single metal transformer, hermetically sealed, surface mount, 0.630" X 0.630", 0.175" max height	HLP-6015
NOT RECOMMENDED	DLP-7014 SLP-8007 SLP-8024

Notes:
1. DLP-7115 operates at +105°C max.

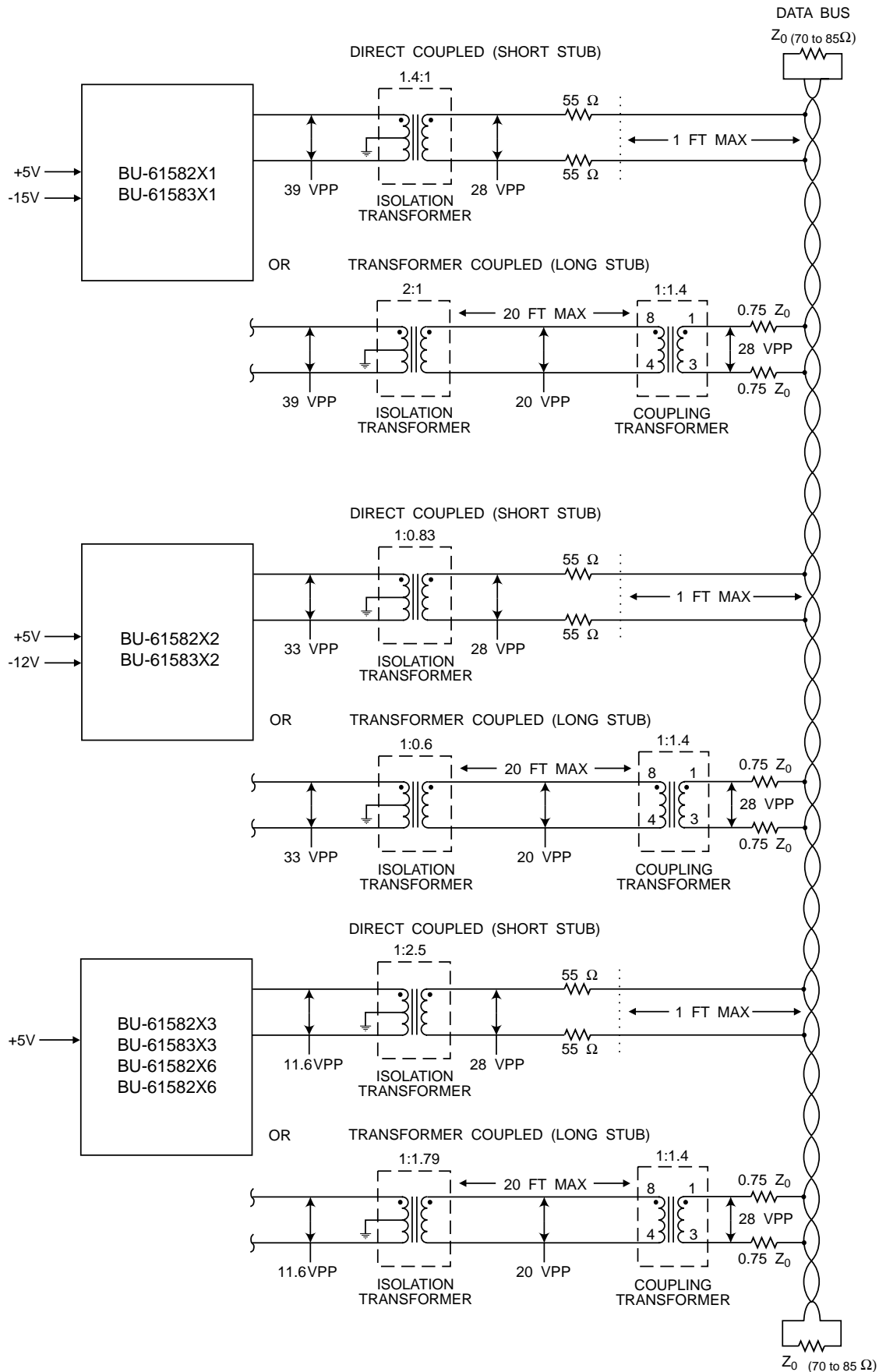

FIGURE 18. INTERFACE TO A 1553 BUS

SIGNAL DESCRIPTIONS, PROCESSOR/MEMORY INTERFACE AND CONTROL (15)

SIGNAL NAME	PIN	DESCRIPTION
TRANSPARENT/ BUFFERED (I)	64	Used to select between the Transparent/ DMA mode (when strapped to logic 1) and the Buffered mode (when strapped to logic 0) for the host processor interface.
STRBD (I)	4	Strobe Data. Used with $\overline{\text{SELECT}}$ to initiate and control the data transfer cycle between the host processor and the BU-61582.
$\overline{\text{SELECT}}$ (I)	3	Generally connected to a CPU address decoder output to select the BU-61582 for a transfer to/from either RAM or register. May be tied to STRBD
$\overline{\text{MEM/REG}}$ (I)	5	Memory/Register. Generally connected to either a CPU address line or address decoder output. Selects between memory access $\overline{\text{MEM/REG}} = 1$ (or register access $\overline{\text{MEM/REG}} = 0$).
$\overline{\text{RD/WR}}$ (I)	6	Read/Write. For host processor access, selects either reading or writing. In the 16-bit buffered mode, if polarity select is logic (0), then $\overline{\text{RD/WR}}$ is low (logic 0) for read accesses and high (logic 1) for write accesses. If polarity select is logic 1 or the configuration of the interface is a mode other than 16-bit buffered mode, then $\overline{\text{RD/WR}}$ is high (logic 1) for read accesses and low (logic 0) for write accesses.
IOEN (O)	67	Tri-state control for external address and data buffers. Generally not needed in the buffered mode. When low, external buffers should be enabled to allow the host processor access to the BU-61582's RAM and registers.
$\overline{\text{READYD}}$ (O)	66	Handshake output to host processor. For a nonzero wait state read access, signals that data is available to be read on D15 through D0. For a nonzero wait state write cycle, signals the completion of data transfer to a register or RAM location. In the buffered zero wait state mode, active high output signal (following the rising edge of STRBD used to indicate the latching of address and data (write only) and that an internal transfer between the address/data latches and the RAM/registers is on-going.
$\overline{\text{INT}}$ (O)	65	Interrupt request output. If the $\overline{\text{LEVEL/PULSE}}$ interrupt bit (bit 3) of Configuration Register #2 is low, a negative pulse of approximately 500 ns in width is output on $\overline{\text{INT}}$. If bit 3 is high, a low level interrupt request output will be asserted on INT.
$\overline{\text{DTREQ}}$ (O) /16/8 (I)	31	Data Transfer Request or 16-bit/8-bit Transfer Mode Select. In transparent mode, active low output signal used to request access to the processor interface bus (address, data, and control buses). In buffered mode, input signal used to select between the 16-bit data transfer mode ($16/8 = \text{logic } 1$) and the 8 bit data transfer mode ($16/8 = \text{logic } 0$).
$\overline{\text{DTGRT}}$ (I) /MSB/LSB (I)	26	Data Transfer Grant or Most Significant Byte/Least Significant Byte. In transparent mode, active low input signal asserted, in response to the DTREQ output, to indicate that access to the processor buses has been granted to the BU-61582. In 8-bit buffered mode, input signal used to indicate which byte is being transferred (MSB or LSB). The POLARITY_SEL input controls the logic sense of MSB/LSB. (Note: only the 8-bit buffered mode uses MSB/LSB.) See description of POLARITY_SEL signal.
$\overline{\text{DTACK}}$ (O)/ POLARITY_SEL (I)	32	Data Transfer Acknowledge or Polarity Select. In transparent mode, active low output signal used to indicate acceptance of the processor interface bus in response to a data transfer grant (DTGR). In 16-bit buffered mode ($\overline{\text{TRANSPARENT/BUFFERED}} = \text{logic } 0$ and $16/8 = \text{logic } 1$), input signal used to control the logic sense of the $\overline{\text{RD/WR}}$ signal. When POLARITY_SEL is logic 1, $\overline{\text{RD/WR}}$ must be asserted high (logic 1) for a read operation and low (logic 0) for a write operation. When POLARITY_SEL is logic 0, $\overline{\text{RD/WR}}$ must be asserted low (logic 0) for a read operation and high (logic 1) for a write operation. In 8-bit buffered mode ($\overline{\text{TRANSPARENT/BUFFERED}} = \text{logic } 0$ and $16/8 = \text{logic } 0$), input signal used to control the logic sense of the MSB/LSB signal. When POLARITY_SEL is logic 0, MSB/LSB must be asserted low (logic 0) to indicate the transfer of the least significant byte and high (logic 1) to indicate the transfer of the most significant byte. When POLARITY_SEL is logic 1, MSB/LSB must be asserted high (logic 1) to indicate the transfer of the least significant byte and low (logic 0) to indicate the transfer of the most significant byte.
$\overline{\text{MEMENA-OUT}}$ (O)	28	Memory Enable Output. Asserted low during both host processor and 1553 protocol/memory management memory transfer cycles. Used as a memory chip select ($\overline{\text{CS}}$) signal for external RAM in the transparent mode.
$\overline{\text{MEMENA-IN}}$ (I) /TRIGGER_SEL (I)	33	Memory Enable Input or Trigger Select. In transparent mode, $\overline{\text{MEMENA_IN}}$ is an active low Chip Select ($\overline{\text{CS}}$) input to the 16K x 16 of internal shared RAM. When only using internal RAM, connect directly to $\overline{\text{MEMENA_OUT}}$. In 8-bit buffered mode, the input signal (TRIGGER_SEL) indicates the order of byte pairs transferred to or from the BU-61582 by the host processor. This signal has no operation (can be N/C) in the 16-bit buffered mode. In the 8-bit buffered mode, TRIGGER_SEL should be asserted high (logic 1) if the byte order for both read operations and write operations is MSB followed by LSB. TRIGGER_SEL should be asserted low (logic 0) if the byte order for both read operations and write operations is LSB followed by MSB.
$\overline{\text{MEMOE}}$ (O)/ ADDR_LAT (I)	29	Memory Output Enable or Address Latch. In transparent mode, $\overline{\text{MEMEO}}$ output will be used to enable data outputs for external RAM read cycles (normally connected to the OE signal on external RAM chips). In buffered mode, ADDR_LAT input will be used to configure the internal address latches in latched mode (when low) or transparent mode (when high).
$\overline{\text{MEMWR}}$ (O) /ZERO_WAIT (I)	30	Memory Write or Zero Wait State. In transparent mode, active low output signal ($\overline{\text{MEMWR}}$) will be asserted low during memory write transfers to strobe data into internal or external RAM (normally connected to the WR signal on external RAM chips). In buffered mode, input signal ($\overline{\text{ZERO_WAIT}}$) will be used to select between the zero wait mode ($\overline{\text{ZERO_WAIT}} = \text{logic } 0$) and the nonzero wait mode ($\overline{\text{ZERO_WAIT}} = \text{logic } 1$).

SIGNAL DESCRIPTIONS, MISCELLANEOUS (5)

SIGNAL NAME	PIN	DESCRIPTION
CLOCK IN (I)	19	16MHz (or 12MHz) clock input.
MSTCLR (I)	7	Master Clear. Negative true Reset input, normally asserted low following power turn-on. Requires a minimum 100ns negative pulse to reset all internal logic to its "power turn-on" state.
INCMD (O)	45	In Command. In BC mode, asserted low throughout processing cycle for each message. In RT mode or Message Monitor mode, asserted low following receipt of Command Word and kept low until completion of current message sequence. In Word Monitor mode, goes low following MONITOR START command, kept low while monitor is on-line, goes high following RESET command.
SSFLAG (I)/ EXT_TRIG (I)	27	Subsystem Flag or External Trigger input. In the Remote Terminal mode, asserting this input, will set the Subsystem Flag bit in the BU-61582's RT Status Word. A low on the SSFLAG input overrides a logic "1" of the respective bit (bit 8) of Configuration Register #1. In the Bus Controller mode, an enabled external BC Start option (bit 7 of Configuration Register #1) and a low-to-high transition on this input will issue a BC Start command, starting execution of the current BC frame. In the Word Monitor mode, an enabled external trigger (bit 7 of Configuration Register #1) and a low-to-high transition on this input will issue a monitor trigger.
TAG_CLK (I)	63	External Time Tag Clock input. Use may be designated by bits 7, 8, and 9 of Configuration Register #2. When used it increments the internal Time Tag Register/Counter. If not used, should be connected to +5V or ground.

SIGNAL DESCRIPTIONS, RT ADDRESS (6)

SIGNAL NAME	PIN	DESCRIPTION
RTAD4 (MSB) (I)	43	Remote Terminal Address Inputs
RTAD3 (I)	42	
RTAD2 (I)	41	
RTAD1 (I)	40	
RTAD0 (LSB) (I)	39	
RTADP (I)	44	Remote Terminal Address Parity. Must provide odd parity sum with RTAD4-RTAD0 in order for the RT to respond to non-broadcast commands.

SIGNAL DESCRIPTIONS, POWER AND GROUND (8)

SIGNAL NAME	PIN	PIN	PIN	PIN	DESCRIPTION
	X0*	X1/X2*	X3*	X6*	
+5V LOGIC	54	54	54	54	Logic +5V Supply
LOGIC GND	18	18	18	18	Logic Ground
-VA	-	70	-	-	CH. A -15V(-12V) Supply
+5VA	-	68	68	68	CH. A +5V Supply
GNDA	-	69	69	69	CH. A Transceiver Ground
-VB	-	36	-	-	CH. B -15V(-12V) Supply
+5VB	-	38	38	38	CH. B +5V Supply
GNDB	-	37	37	37	CH. B Transceiver Ground

Note: *Pin X0, X1/X2, X3, X6 refer to package option(X) and Voltage Transceiver option (0, 1, 2, 3, 6). See ordering information.
For X1/X2 versions logic GND, GNDA + GNDB are internally connected.

SIGNAL DESCRIPTIONS, 1553 ISOLATION TRANSFORMER INTERFACE (4)

SIGNAL NAME	PIN	PIN	PIN	PIN	DESCRIPTION
	X0*	X1/X2*	X3*	X6*	
TX/RX-A (I/O)	-	1	1	1	Analog Transmit/Receive Input/Outputs. Connect directly to 1553 isolation transformers.
$\overline{\text{TX}}/\overline{\text{RX}}\text{-A}$ (I/O)	-	2	2	2	
TX/RX-B (I/O)	-	34	34	34	
$\overline{\text{TX}}/\overline{\text{RX}}\text{-B}$ (I/O)	-	35	35	35	

Note: *Pin X0, X1/X2, X3, X6 refer to package option(X) and Voltage Transceiver option (0, 1, 2, 3, 6). See ordering information.

SIGNAL DESCRIPTIONS, ADDRESS BUS (16)

SIGNAL NAME	PIN	DESCRIPTION
A15 (MSB)	8	16-bit bidirectional address bus. In both the buffered and transparent modes, the host CPU accesses the BU-61582 registers and 16K words of internal RAM by A13 through A0. The host CPU performs register selection by A4 through A0. In the buffered mode, A15-A0 are inputs only. In the transparent mode, A15-A0 are inputs during CPU accesses and drive outward (towards the CPU) when the 1553 protocol/memory management logic accesses up to 64K x 16 of external RAM. The address bus drives outward only in the transparent mode when the signal $\overline{\text{DTACK}}$ is low (indicating that the 61582 has control of the processor interface bus) and $\overline{\text{IOEN}}$ is high (indicating that this is not a CPU access). Most of the time, including immediately after power turn-on RESET, the A15-A0 outputs will be in their disabled (high impedance) state.
A14	9	
A13	10	
A12	11	
A11	12	
A10	13	
A09	14	
A08	15	
A07	16	
A06	17	
A05	20	
A04	21	
A03	22	
A02	23	
A01	24	
A00	25	

SIGNAL DESCRIPTIONS, DATA BUS (16)		
SIGNAL NAME	PIN	DESCRIPTION
D15 (MSB)	62	16-bit bidirectional data bus. This bus interfaces the host processor to the internal registers and 16K words of RAM. In addition, in the transparent mode, this bus allows data transfers to take place between the internal protocol/memory management logic and up to 64K x 16 of external RAM. Most of the time, the outputs for D15 through D0 are in their high impedance state. They drive outward in the buffered or transparent mode when the host CPU reads the internal RAM or registers. Or, in the transparent mode, when the protocol/memory management logic is accessing (either reading or writing) internal RAM or writing to external RAM.
D14	61	
D13	60	
D12	59	
D11	58	
D10	57	
D09	56	
D08	55	
D07	53	
D06	52	
D05	51	
D04	50	
D03	49	
D02	48	
D01	47	
D00	46	

SIGNAL DESCRIPTIONS, TRANSMITTER/RECEIVERS (14)					
SIGNAL NAME	PIN	PIN	PIN	PIN	DESCRIPTION
	X0	X1/X2	X3	X6	
TXA	70	-	-	-	Digital manchester biphas transmit data outputs. Connect directly to corresponding inputs to a MIL-STD-1553 or MIL-STD-1773 (fiber optic) transceiver.
$\overline{\text{TXA}}$	69	-	-	-	
TXB	38	-	-	-	
$\overline{\text{TXB}}$	37	-	-	-	
RXA	1	-	-	-	Digital manchester biphas receive data inputs. Connect directly to corresponding outputs of a MIL-STD-1553 or MIL-STD-1773 transceiver.
$\overline{\text{RXA}}$	2	-	-	-	
RXB	35	-	-	-	
$\overline{\text{RXB}}$	34	-	-	-	
TX_INH_A_IN	-	-	-	70	Transmitter inhibit inputs for the Channel A and Channel B MIL-STD-1553 transmitters. For normal operation, these inputs should be connected to logic "0". To force a shutdown of Channel A and/or Channel B, a value of logic "1" should be applied to the respective TX_INH input.
TX_INH_B_IN	-	-	-	36	
TX_INH_A_OUT	68	-	-	-	Digital Transmit Inhibit outputs. Connect to TX_INH_OUT inputs of a MIL-STD-1553 transceiver. Asserted high to inhibit when not transmitting on the respective bus.
TX_INH_B_OUT	36	-	-	-	
N/C	-	-	36	-	No User Connections
N/C	-	-	70	-	

Note: *Pin X0, X1/X2, X3, X6 refer to package option(X) and Voltage Transceiver option (0, 1, 2, 3, 6). See ordering information.

BU-61582 PIN LISTING (70-PIN DIP, FLAT PACK)

PIN	SIGNAL NAME				PIN	SIGNAL NAME			
	X0	X1, X2	X3	X6		X0	X1, X2	X3	X6
1	RXA	TX/RX-A			36	TX_INH_OUT_B	-VB (Note 2)	N/C	TX_INH_IN_B
2	$\overline{\text{RXA}}$	$\overline{\text{TX/RX-A}}$			37	$\overline{\text{TXB}}$	GNDB		
3	$\overline{\text{SELECT}}$				38	TXB	+5VB		
4	$\overline{\text{STRBD}}$				39	RTAD0			
5	MEM/REG				40	RTAD1			
6	RD/WR				41	RTAD2			
7	$\overline{\text{MSTCLR}}$				42	RTAD3			
8	A15				43	RTAD4			
9	A14				44	RTADP			
10	A13				45	$\overline{\text{INCMD}}$			
11	A12				46	D00			
12	A11				47	D01			
13	A10				48	D02			
14	A09				49	D03			
15	A08				50	D04			
16	A07				51	D05			
17	A06				52	D06			
18	LOGIC GND				53	D07			
19	CLOCK_IN				54	+5V Logic			
20	A05				55	D08			
21	A04				56	D09			
22	A03				57	D10			
23	A02				58	D11			
24	A01				59	D12			
25	A00				60	D13			
26	$\overline{\text{DTGRT/MSB/LSB}}$				61	D14			
27	$\overline{\text{SSFLAG/EXT_TRIG}}$				62	D15			
28	$\overline{\text{MEMENA_OUT}}$				63	TAG_CLK			
29	$\overline{\text{MEMOE/ADDR_LAT}}$				64	TRANSPARENT/ $\overline{\text{BUFFERED}}$			
30	$\overline{\text{MEMWR/ZERO_WAIT}}$				65	$\overline{\text{INT}}$			
31	$\overline{\text{DTREQ/16/8}}$				66	READYD			
32	$\overline{\text{DTACK/POLARITY_SEL}}$				67	$\overline{\text{IOEN}}$			
33	MEMENA_IN/TRIGGER_SEL				68	TX_INH_OUT_A	+5VA		
34	RX-B	TX/RX-B			69	$\overline{\text{TXA}}$	GNDA		
35	RX-B	$\overline{\text{TX/RX-B}}$			70	TXA	-VA (Note 2)	N/C	TX_INH_IN_A

Notes:

- 1) Pin X0, X1/X2, X3, X6 refer to package option(X) and Voltage Transceiver option (0, 1, 2, 3, 6). See ordering information.
- 2) -15V for BU-61582X1
 -12V for BU-61582X2.

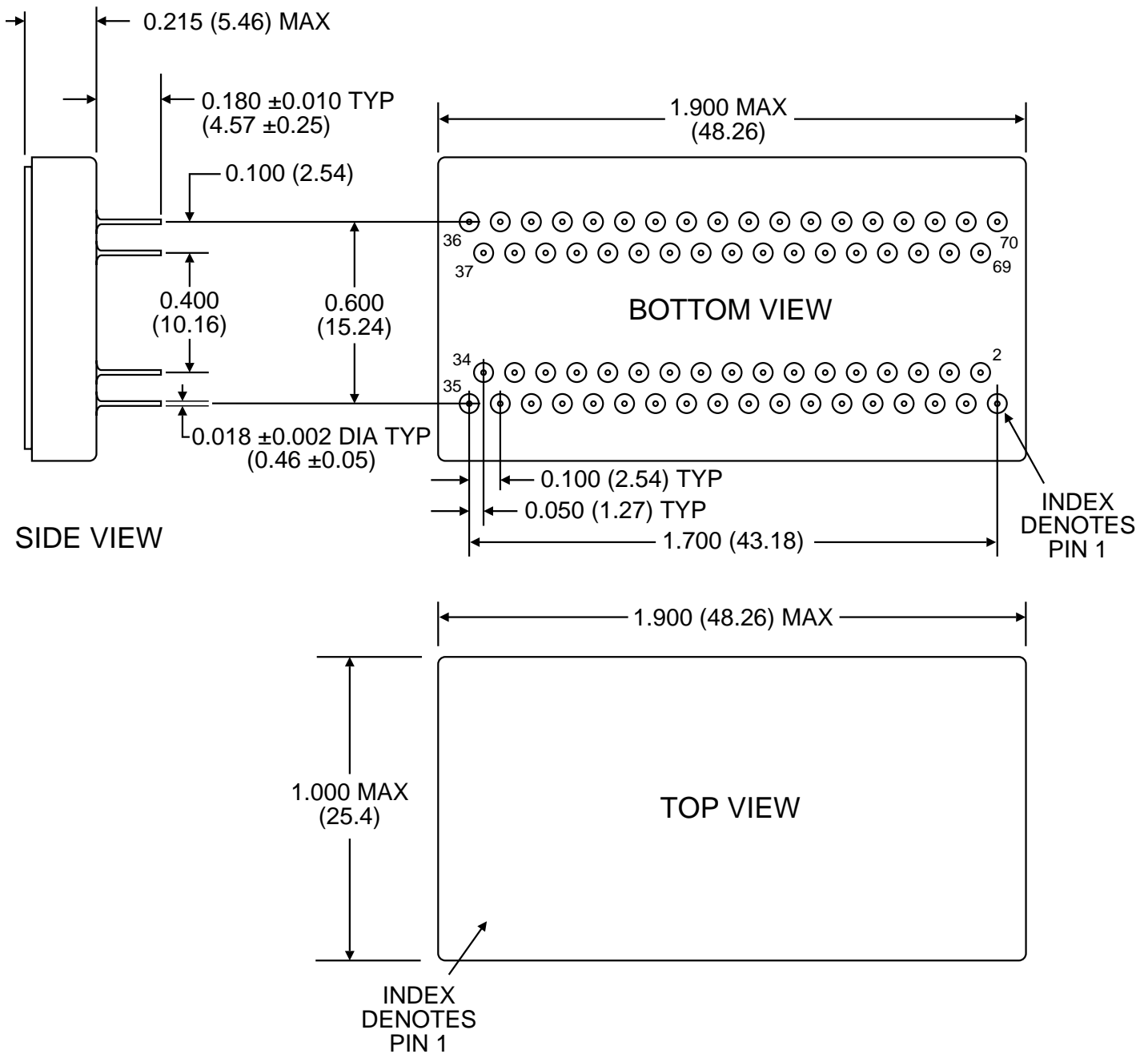

NOTES:

1. DIMENSIONS ARE IN INCHES (MILLIMETERS).
2. PACKAGE MATERIAL: ALUMINA (AL₂O₃).
3. LEAD MATERIAL: KOVAR, PLATED BY 150μ MINIMUM NICKEL, PLATED BY 50μ MINIMUM GOLD.

FIGURE 19. BU-61582DX, 70-PIN DIP CERAMIC MECHANICAL OUTLINE

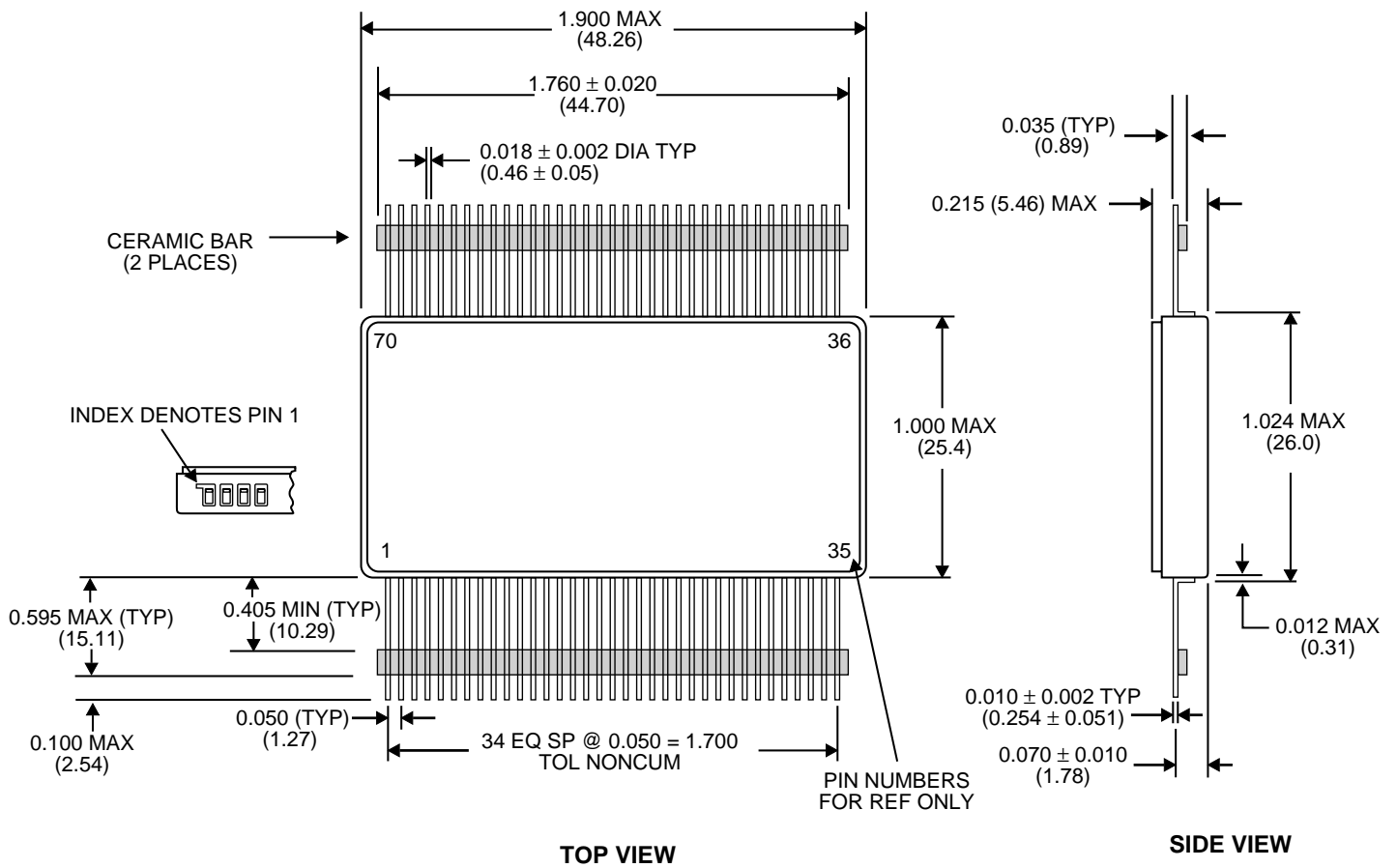

NOTES:

1. DIMENSIONS ARE IN INCHES (MILLIMETERS).
2. PACKAGE MATERIAL: ALUMINA (Al_2O_3).
3. LEAD MATERIAL: KOVAR, PLATED BY 150μ MINIMUM NICKEL, PLATED BY 50μ MINIMUM GOLD.

FIGURE 20. BU-61582FX, 70-PIN FLAT PACK CERAMIC MECHANICAL OUTLINE

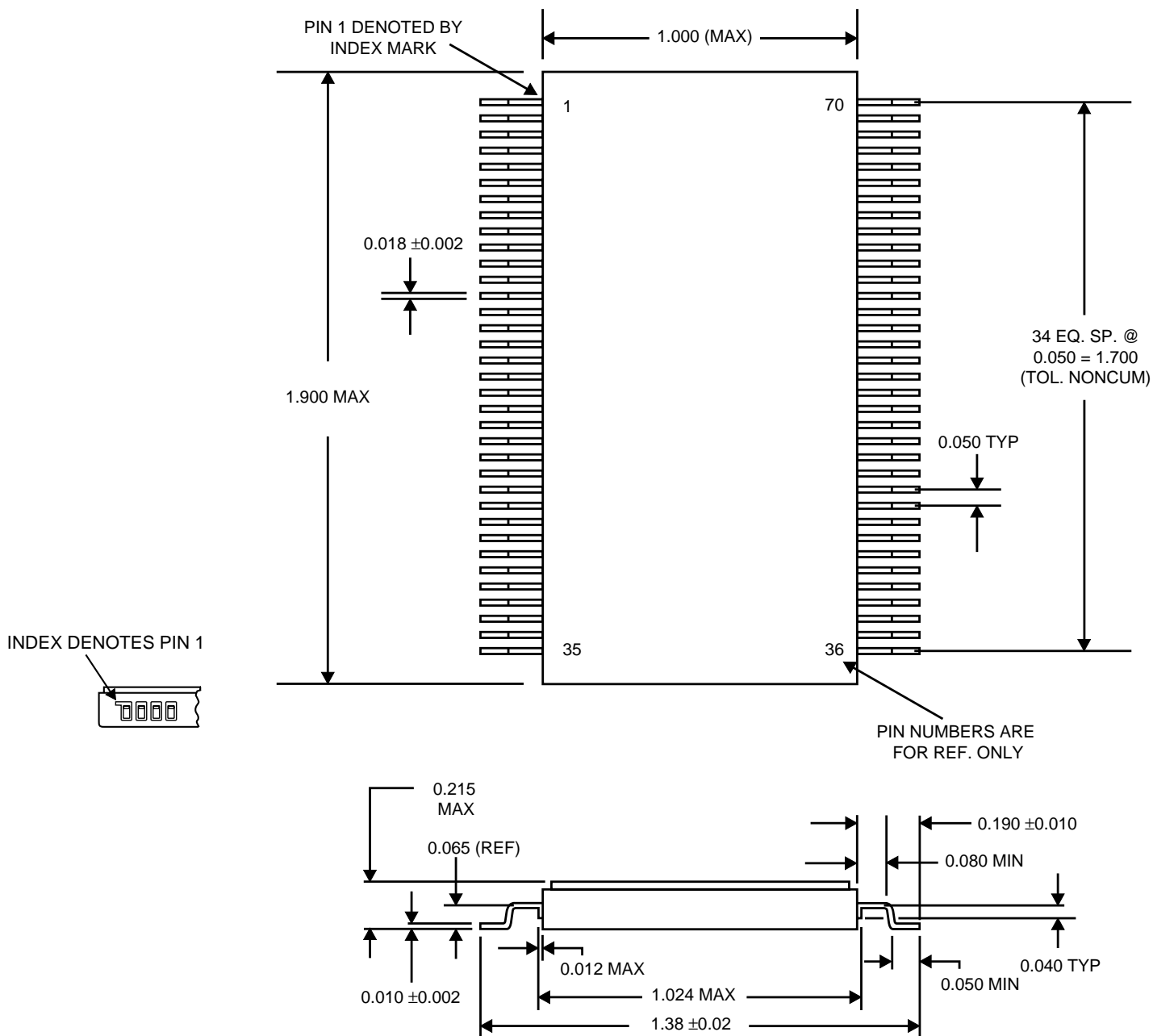

NOTES:

1. DIMENSIONS ARE IN INCHES (MILLIMETERS).
2. PACKAGE MATERIAL: ALUMINA (AL₂O₃).
3. LEAD MATERIAL: KOVAR, PLATED BY 150μ MINIMUM NICKEL, PLATED BY 50μ MINIMUM GOLD.

FIGURE 21. BU-61582GX, 70-PIN GULL LEAD CERAMIC MECHANICAL OUTLINE

ORDERING INFORMATION

BU-61582XX-XXXX

Supplemental Process Requirements:

- S = Pre-Cap Source Inspection
- L = Pull Test
- Q = Pull Test and Pre-Cap Inspection
- K = One Lot Date Code
- W = One Lot Date Code and PreCap Source
- Y = One Lot Date Code and 100% Pull Test
- Z = One Lot Date Code, PreCap Source and 100% Pull Test
- Blank = None of the Above

Other Criteria:

- 0 = No X Ray
- 1 = X Ray

Process Requirements:

- 0 = Standard DDC Processing, no Burn-In
- 1 = MIL-PRF-38534 Compliant*
- 2 = B**
- 3 = MIL-PRF-38534 Compliant with PIND Testing*
- 4 = MIL-PRF-38534 Compliant with Solder Dip*
- 5 = MIL-PRF-38534 Compliant with PIND Testing and Solder Dip*
- 6 = B** with PIND Testing
- 7 = B** with Solder Dip
- 8 = B** with PIND Testing and Solder Dip
- 9 = Standard DDC Processing with Solder Dip, no Burn-In

Temperature Grade/Data Requirements:

- 1 = -55°C to +125°C
- 2 = -40°C to +85°C
- 3 = 0°C to +70°C
- 4 = -55°C to +125°C with Variables Test Data
- 5 = -40°C to +85°C with Variables Test Data
- 8 = 0°C to +70°C with Variables Test Data

Voltage Transceiver Option:

- 0 = No Transceiver
- 1 = +5/-15 V
- 2 = +5/-12 V
- 3 = +5/+5 V
- 6 = +5/+5 V with Transmit Inhibit (TX_INHIBIT)

Package:

- D = DIP
- F = Flat Pack
- G = Gull Leads (Above "Process Requirements" must include solder dip.)

Product Type:

- 61582 = 70-Pin BC/RT/MT with 16K x 16 Internal RAM
- 61583 = 70-Pin BC/RT/MT with 16K x 16 Internal RAM and with RT Address Latch

*MIL-PRF-38534 Compliant products include 320 hours of burn-in and 100% non-destruct pull-test. "Supplemental Process Requirements" must be an "L" or a "Q" for MIL-PRF-38534 compliant parts.

**Standard DDC Processing with burn-in and full temperature test.

The information in this data sheet is believed to be accurate; however, no responsibility is assumed by Data Device Corporation for its use, and no license or rights are granted by implication or otherwise in connection therewith.
Specifications are subject to change without notice.



105 Wilbur Place, Bohemia, New York, U.S.A. 11716-2482

For Technical Support - 1-800-DDC-5757 ext. 7234

Headquarters, N.Y., U.S.A. - Tel: (631) 567-5600, Fax: (631) 567-7358

Southeast, U.S.A. - Tel: (703) 450-7900, Fax: (703) 450-6610

West Coast, U.S.A. - Tel: (714) 895-9777, Fax: (714) 895-4988

United Kingdom - Tel: +44-(0)1635-811140, Fax: +44-(0)1635-32264

Ireland - Tel: +353-21-341065, Fax: +353-21-341568

France - Tel: +33-(0)1-41-16-3424, Fax: +33-(0)1-41-16-3425

Germany - Tel: +49-(0)8141-349-087, Fax: +49-(0)8141-349-089

Japan - Tel: +81-(0)3-3814-7688, Fax: +81-(0)3-3814-7689

World Wide Web - <http://www.ddc-web.com>

