

This document was generated on 06/08/2010

PLEASE CHECK WWW.MOLEX.COM FOR LATEST PART INFORMATION

Part Number: **0190040001**
Status: **Active**
Description: InsulKrimp™ Fully Insulated Coupler, Male, for 18-22 AWG Wire, Box

Documents:

[Drawing \(PDF\)](#) [RoHS Certificate of Compliance \(PDF\)](#)
[Product Specification PS-19902-008 \(PDF\)](#)

Agency Certification

CSA LR18689
 UL E79133

General

Product Family Quick Disconnects
 Series 19004
 Crimp Quality Equipment Yes
 MolexKits Yes
 Product Name InsulKrimp™
 Type Quick Disconnect

Physical

Barrel Type Closed
 Color - Resin Natural
 Flammability 94V-0, 94V-2
 Gender Male
 Glow-Wire Compliant No
 Insulation Nylon (PA)
 Lock to Mating Part None
 Material - Metal Brass
 Material - Plating Mating Zinc Chromate
 Material - Plating Termination Zinc Chromate
 Material - Resin Nylon
 Orientation Straight
 Packaging Type Bag
 Plating min: Mating (µin) 200
 Plating min: Mating (µm) 5
 Plating min: Termination (µin) 200
 Plating min: Termination (µm) 5
 Polarized to Mating Part No
 Tab Thickness 0.81mm (.032")
 Tab Width 6.35mm (.250")
 Temperature Range - Operating -65°C to +105°C
 Wire Insulation Diameter 3.68mm (.145") max.
 Wire Size AWG 18, 20, 22
 Wire Size mm² 0.35 - 0.80

Electrical

Voltage - Maximum 600V

Material Info

Old Part Number AA-2260

Reference - Drawing Numbers

Product Specification PS-19902-008
 Sales Drawing SD-19004-001

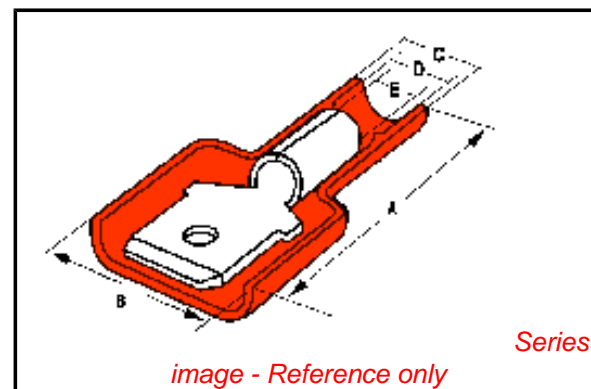

EU RoHS

ELV and RoHS Compliant
REACH SVHC
 Not Reviewed
Halogen-Free Status
 Not Reviewed

China RoHS



Need more information on product environmental compliance?

Email productcompliance@molex.com
 For a multiple part number RoHS Certificate of Compliance, [click here](#)

Please visit the [Contact Us](#) section for any non-product compliance questions.

Search Parts in this Series

[19004Series](#)

Use With

[19005-0001](#) , [19005-0003](#) , [19005-0004](#)

Application Tooling | FAQ

Tooling specifications and manuals are found by selecting the products below. Crimp Height Specifications are then contained in the Application Tooling Specification document.

Global

Description	Product #
Hand Crimp Tool	0640014700
Crimp Head for the AT-200™ Pneumatic Hand Tool	0640054700

This document was generated on 06/08/2010

PLEASE CHECK WWW.MOLEX.COM FOR LATEST PART INFORMATION

ASSEMBLY NUMBER		TAPE NUMBER		ITEM DESCRIPTION			DIMENSIONS					
MATERIAL NUMBER	ENGINEERING NUMBER	MATERIAL NUMBER	TAPE ENG. NUMBER	COLOR	WIRE GAUGE	TAB SIZE	'A' MAX	'B' MAX	'C' MAX	'D' MIN	'E' MIN	'H' REF
190040001	AA-2260	190040004	AA-2260T	RED	22-18 AWG (0.38-0.96mm ²)	.250x.032 (6.35x0.81)	.97/24.6	.45/11.4	.23/5.8	.145/3.68	(B).054/1.37	.48/12.2
190040005	BB-2262	190040008	BB-2262T	BLUE	16-14 AWG (1.23-1.94 mm ²)	.250x.032 (6.35x0.81)	.97/24.6	.45/11.4	.23/5.8	.170/4.32	.083/2.11	.48/12.2

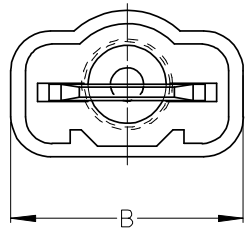
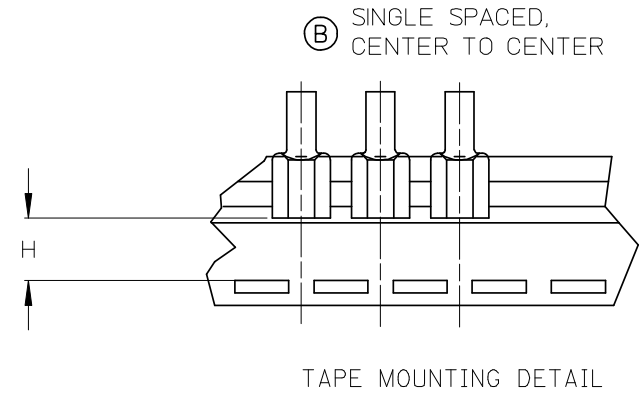
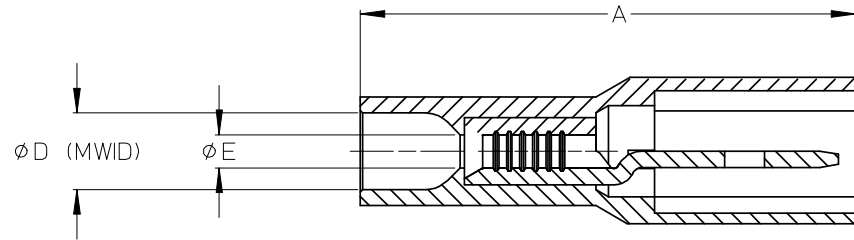
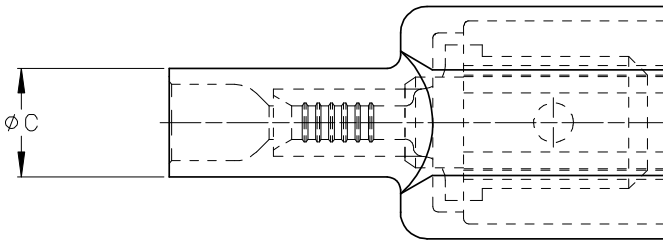

- (B) NOTES:
1. TERMINAL MATERIAL: BRASS
 2. TERMINAL PLATING: ZINC CHROMATE
 3. HOUSING: 6/6 NYLON
 4. MWID: MAXIMUM WIRE INSULATION DIAMETER
 5. TAB DIMENSIONS CONFORM TO UL310 SPECIFICATIONS.
 6. ASSEMBLY IS ROHS COMPLIANT

REDRAW, MATERIALS EC NO: ETC2007-0081 DRAWN:EHILE 2008/01/28 CHKD:MACNEIL 2008/01/28 APPR:JMACNEIL 2008/02/13 REV B	QUALITY SYMBOLS ▼=0 ▽=0	GENERAL TOLERANCES (UNLESS SPECIFIED) <table border="1"> <thead> <tr> <th></th> <th>mm</th> <th>INCH</th> </tr> </thead> <tbody> <tr> <td>4 PLACES</td> <td>±---</td> <td>±---</td> </tr> <tr> <td>3 PLACES</td> <td>±---</td> <td>±---</td> </tr> <tr> <td>2 PLACES</td> <td>±---</td> <td>±---</td> </tr> <tr> <td>1 PLACE</td> <td>±---</td> <td>±---</td> </tr> <tr> <td colspan="3">ANGULAR ±---°</td> </tr> </tbody> </table>		mm	INCH	4 PLACES	±---	±---	3 PLACES	±---	±---	2 PLACES	±---	±---	1 PLACE	±---	±---	ANGULAR ±---°			DIMENSION STYLE IN/MM (B)	SCALE 4:1	DESIGN UNITS INCH	THIRD ANGLE PROJECTION
		mm	INCH																					
	4 PLACES	±---	±---																					
	3 PLACES	±---	±---																					
2 PLACES	±---	±---																						
1 PLACE	±---	±---																						
ANGULAR ±---°																								
DRAFT WHERE APPLICABLE MUST REMAIN WITHIN DIMENSIONS		DRAWN BY EMF	DATE 1993/06/25	TITLE FULLY INSULATED MALE COUPLER, INSULKRIMP																				
		CHECKED BY	DATE	MOLEX INCORPORATED																				
		APPROVED BY	DATE	MATERIAL NO. SEE CHART	DOCUMENT NO. SD-19004-001	SHEET NO. 1 OF 1																		

THIS DRAWING CONTAINS INFORMATION THAT IS PROPRIETARY TO MOLEX INCORPORATED AND SHOULD NOT BE USED WITHOUT WRITTEN PERMISSION