

High Slew Rate Operational Amplifier

The HA-2510/883 is a high performance operational amplifier which sets the standards for maximum slew rate and wide bandwidth operation in moderately powered, internally compensated, monolithic devices. In addition to excellent dynamic characteristics, this dielectrically isolated amplifier also offers low offset current and high input impedance.

The $\pm 50V/\mu s$ minimum slew rate and fast settling time of the HA-2510/883 are ideally suited for high speed D/A, A/D, and pulse amplification designs. The HA-2510/883's superior bandwidth and 750kHz minimum full power bandwidth are extremely useful in RF and video applications. To insure compliance with slew rate and transient response specifications, all devices are 100% tested for AC performance characteristics over full temperature limits. To improve signal conditioning accuracy, the HA-2510/883 provides a maximum offset current of 25nA and a minimum input impedance of $50M\Omega$, both at $25^{\circ}C$, as well as offset voltage adjust capability.

Ordering Information

PART NUMBER	PART MARKING	TEMP. RANGE (°C)	PACKAGE	PKG. DWG. #
HA2-2510/883	HA2-2510/883	-55 to 125	8 Pin Can	T8.C
HA7-2510/883	HA7-2510/883	-55 to 125	8 Ld CERDIP	F8.3A

Features

- This Circuit is Processed in Accordance to MIL-STD-883 and is Fully Conformant Under the Provisions of Paragraph 1.2.1.
- High Slew Rate $50V/\mu s$ (Min)
 $65V/\mu s$ (Typ)
- Wide Power Bandwidth 750kHz (Min)
- Low Offset Current 25nA (Min)
10nA (Typ)
- High Input Impedance $50M\Omega$ (Min)
 $100M\Omega$ (Typ)
- Wide Small Signal Bandwidth 12MHz (Typ)
- Fast Settling Time (0.1% of 10V Step) 250ns (Typ)
- Low Quiescent Supply Current 6mA (Max)
- Internally Compensated For Unity Gain Stability

Applications

- Data Acquisition Systems
- RF Amplifiers
- Video Amplifiers
- Signal Generators
- Pulse Amplification

Pinouts

HA-2510/883 (CERDIP) TOP VIEW

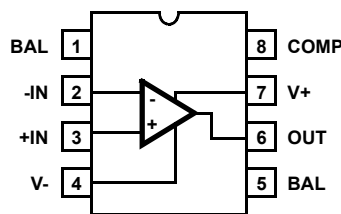

HA-2510/883 (METAL CAN) TOP VIEW

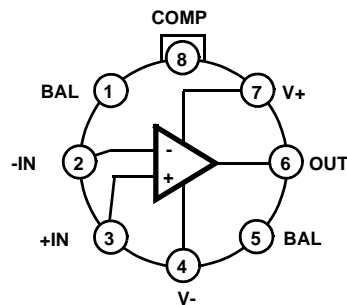

Absolute Maximum Ratings

Voltage Between V+ and V- Terminals40V
 Differential Input Voltage15V
 Voltage at Either Input Terminal V+ to V-
 Peak Output Current 50mA
 ESD Rating<2000V

Operating Conditions

Temperature Range..... -55°C to 125°C
 Supply Voltage ±15V
 $V_{INCM} \leq 1/2 (V+ - V-)$
 $R_L \geq 2k\Omega$

Thermal Information

Thermal Resistance (Typical, Note 1) θ_{JA} θ_{JC}
 Metal Can Package 160°C/W 75°C/W
 CERDIP Package..... 120°C/W 30°C/W
 Package Power Dissipation Limit at 75°C for $T_J \leq 175^\circ C$
 Metal Can Package 625mW
 CERDIP Package..... 870mW
 Package Power Dissipation Derating Factor Above 75°C
 Metal Can Package 6.3mW/°C
 CERDIP Package..... 8.7mW/°C
 Maximum Junction Temperature.....175°C
 Maximum Storage Temperature Range -65°C to 150°C
 Maximum Lead Temperature (Soldering 10s).....300°C

CAUTION: Stresses above those listed in "Absolute Maximum Ratings" may cause permanent damage to the device. This is a stress only rating and operation of the device at these or any other conditions above those indicated in the operational sections of this specification is not implied.

NOTE:

- θ_{JA} is measured with the component mounted on a low effective thermal conductivity test board in free air. See Tech Brief TB379 for details.

TABLE 1. DC ELECTRICAL PERFORMANCE CHARACTERISTICS

Device Tested at: $V_{SUPPLY} = \pm 15V$, $R_{SOURCE} = 100\Omega$, $R_{LOAD} = 500k\Omega$, $V_{OUT} = 0V$, Unless Otherwise Specified.

PARAMETER	SYMBOL	CONDITIONS	GROUP A SUBGROUPS	TEMP (°C)	MIN	MAX	UNITS
Input Offset Voltage	V_{IO}	$V_{CM} = 0V$	1	25	-8	8	mV
			2, 3	125, -55	-18	10	mV
Input Bias Current	+ I_B	$V_{CM} = 0V$, $+R_S = 100k\Omega$, $-R_S = 100\Omega$	1	25	-200	200	nA
			2, 3	125, -55	-400	400	nA
	- I_B	$V_{CM} = 0V$, $+R_S = 100\Omega$, $-R_S = 100k\Omega$	1	25	-200	200	nA
			2, 3	125, -55	-400	400	nA
Input Offset Current	I_{IO}	$V_{CM} = 0V$, $+R_S = 100k\Omega$, $-R_S = 100k\Omega$	1	25	-25	25	nA
			2, 3	125, -55	-50	50	nA
Common Mode Range	+CMR	$V+ = 5V$, $V- = -25V$	1	25	+10	-	V
			2, 3	125, -55	+10	-	V
	-CMR	$V+ = 25V$, $V- = -5V$	1	25	-	-10	V
			2, 3	125, -55	-	-10	V
Large Signal Voltage Gain	+ A_{VOL}	$V_{OUT} = 0V$ and $+10V$, $R_L = 2k\Omega$	4	25	10	-	kV/V
			5, 6	125, -55	7.5	-	kV/V
	- A_{VOL}	$V_{OUT} = 0V$ and $-10V$, $R_L = 2k\Omega$	4	25	10	-	kV/V
			5, 6	125, -55	7.5	-	kV/V
Common Mode Rejection Ratio	+CMRR	$\Delta V_{CM} = +10V$, $V+ = +5V$, $V- = -25V$, $V_{OUT} = -10V$	1	25	80	-	dB
			2, 3	125, -55	80	-	dB
	-CMRR	$\Delta V_{CM} = -10V$, $V+ = +25V$, $V- = -5V$, $V_{OUT} = +10V$	1	25	80	-	dB
			2, 3	125, -55	80	-	dB

TABLE 1. DC ELECTRICAL PERFORMANCE CHARACTERISTICS (Continued)

Device Tested at: $V_{SUPPLY} = \pm 15V$, $R_{SOURCE} = 100\Omega$, $R_{LOAD} = 500k\Omega$, $V_{OUT} = 0V$, Unless Otherwise Specified.

PARAMETER	SYMBOL	CONDITIONS	GROUP A SUBGROUPS	TEMP (°C)	MIN	MAX	UNITS
Output Voltage Swing	+V _{OUT}	R _L = 2kΩ	4	25	10	-	V
			5, 6	125, -55	10	-	V
	-V _{OUT}	R _L = 2kΩ	4	25	-	-10	V
			5, 6	125, -55	-	-10	V
Output Current	+I _{OUT}	V _{OUT} = -10V	4	25	10	-	mA
			5, 6	125, -55	7.5	-	mA
	-I _{OUT}	V _{OUT} = +10V	4	25	-	-10	mA
			5, 6	125, -55	-	-7.5	mA
Quiescent Power Supply Current	+I _{CC}	V _{OUT} = 0V, I _{OUT} = 0mA	1	25	-	6	mA
			2, 3	125, -55	-	6.5	mA
	-I _{CC}	V _{OUT} = 0V, I _{OUT} = 0mA	1	25	-6	-	mA
			2, 3	125, -55	-6.5	-	mA
Power Supply Rejection Ratio	+PSRR	$\Delta V_{SUP} = 10V$, V+ = +20V, V- = -15V, V+ = +10V, V- = -15V	1	25	80	-	dB
			2, 3	125, -55	80	-	dB
	-PSRR	$\Delta V_{SUP} = 10V$, V+ = +15V, V- = -20V, V+ = +15V, V- = -10V	1	25	80	-	dB
			2, 3	125, -55	80	-	dB
Offset Voltage Adjustment	+V _{IOAdj}	Note 2	1	25	V _{IO} -1	-	mV
			2, 3	125, -55	V _{IO} -1	-	mV
	-V _{IOAdj}	Note 2	1	25	V _{IO} +1	-	mV
			2, 3	125, -55	V _{IO} +1	-	mV

NOTE:

- Offset adjustment range is [V_{IO}(Measured) ± 1mV] minimum referred to output. This test is for functionality only to assure adjustment through 0V.

TABLE 2. AC ELECTRICAL PERFORMANCE CHARACTERISTICS

Device Tested at: $V_{SUPPLY} = \pm 15V$, $R_{SOURCE} = 50\Omega$, $R_{LOAD} = 2k\Omega$, $C_{LOAD} = 50pF$, $A_{VCL} = +1V/V$, Unless Otherwise Specified.

PARAMETER	SYMBOL	CONDITIONS	GROUP A SUBGROUPS	TEMP (°C)	MIN	MAX	UNITS
Slew Rate	+SR	V _{OUT} = -5V to +5V, 25% ≤ +SR ≤ 75%	7	25	50	-	V/μs
			8A, 8B	125, -55	45	-	V/μs
	-SR	V _{OUT} = +5V to -5V, 75% ≥ -SR ≥ 25%	7	25	50	-	V/μs
			8A, 8B	125, -55	45	-	V/μs
Rise and Fall Time	t _r	V _{OUT} = 0 to +200mV, 10% ≤ t _r ≤ 90%	7	25	-	50	ns
			8A, 8B	125, -55	-	60	ns
	t _f	V _{OUT} = 0 to -200mV, 10% ≤ t _f ≤ 90%	7	25	-	50	ns
			8A, 8B	125, -55	-	60	ns

TABLE 2. AC ELECTRICAL PERFORMANCE CHARACTERISTICS (Continued)

Device Tested at: $V_{SUPPLY} = \pm 15V$, $R_{SOURCE} = 50\Omega$, $R_{LOAD} = 2k\Omega$, $C_{LOAD} = 50pF$, $A_{VCL} = +1V/V$, Unless Otherwise Specified.

PARAMETER	SYMBOL	CONDITIONS	GROUP A SUBGROUPS	TEMP (°C)	MIN	MAX	UNITS
Overshoot	+OS	$V_{OUT} = 0$ to +200mV	7	25	-	40	%
			8A, 8B	125, -55	-	50	%
	-OS	$V_{OUT} = 0$ to -200mV	7	25	-	40	%
			8A, 8B	125, -55	-	50	%

TABLE 3. ELECTRICAL PERFORMANCE CHARACTERISTICS

Device Characterized at: $V_{SUPPLY} = \pm 15V$, $R_{LOAD} = 2k\Omega$, $C_{LOAD} = 50pF$, Unless Otherwise Specified.

PARAMETER	SYMBOL	CONDITIONS	NOTES	TEMP (°C)	MIN	MAX	UNITS
Differential Input Resistance	R_{IN}	$V_{CM} = 0V$	3	25	50	-	$M\Omega$
Full Power Bandwidth	FPBW	$V_{PEAK} = 10V$	3, 4	25	750	-	kHz
Minimum Closed Loop Stable Gain	CLSG	$R_L = 2k\Omega$, $C_L = 50pF$	3	-55 to 125	1	-	V/V
Quiescent Power Consumption	PC	$V_{OUT} = 0V$, $I_{OUT} = 0mA$	3, 5	-55 to 125	-	195	mW

NOTES:

- Parameters listed in Table 3 are controlled via design or process parameters and are not directly tested at final production. These parameters are lab characterized upon initial design release, or upon design changes. These parameters are guaranteed by characterization based upon data from multiple production runs which reflect lot to lot and within lot variation.
- Full Power Bandwidth guarantee based on Slew Rate measurement using $FPBW = Slew\ Rate / (2\pi V_{PEAK})$.
- Quiescent Power Consumption based upon Quiescent Supply Current test maximum. (No load on outputs.)

TABLE 4. ELECTRICAL TEST REQUIREMENTS

MIL-STD-883 TEST REQUIREMENTS	SUBGROUPS (SEE TABLES 1 AND 2)
Interim Electrical Parameters (Pre Burn-In)	1
Final Electrical Test Parameters	1 (Note 6), 2, 3, 4, 5, 6, 7, 8A, 8B
Group A Test Requirements	1, 2, 3, 4, 5, 6, 7, 8A, 8B
Groups C and D Endpoints	1

NOTE:

- PDA applies to Subgroup 1 only.

Die Characteristics

SUBSTRATE POTENTIAL (Powered Up):

Unbiased

TRANSISTOR COUNT:

40

PROCESS: Bipolar Dielectric Isolation

Metallization Mask Layout

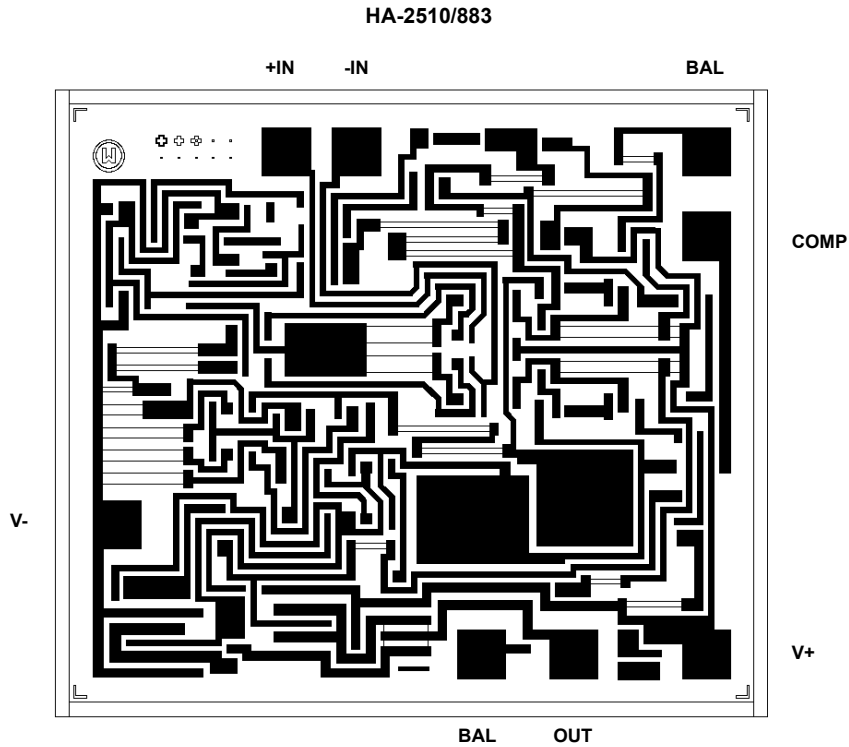

Burn-In Circuit

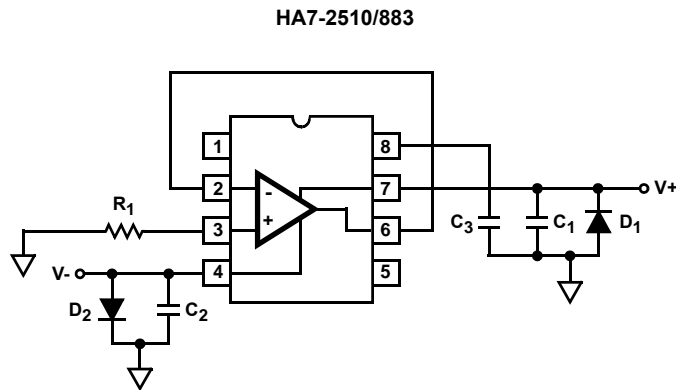

- R₁ = 1MΩ, ±5%, 1/4W (Min)
- C₁ = C₂ = 0.01μF/Socket (Min) or 0.1μF/Row (Min)
- C₃ = 0.01μF/Socket (10%)
- D₁ = D₂ = 1N4002 or Equivalent/Board
- |V₊ - V₋| = 30V

Metal Can Packages (Can)

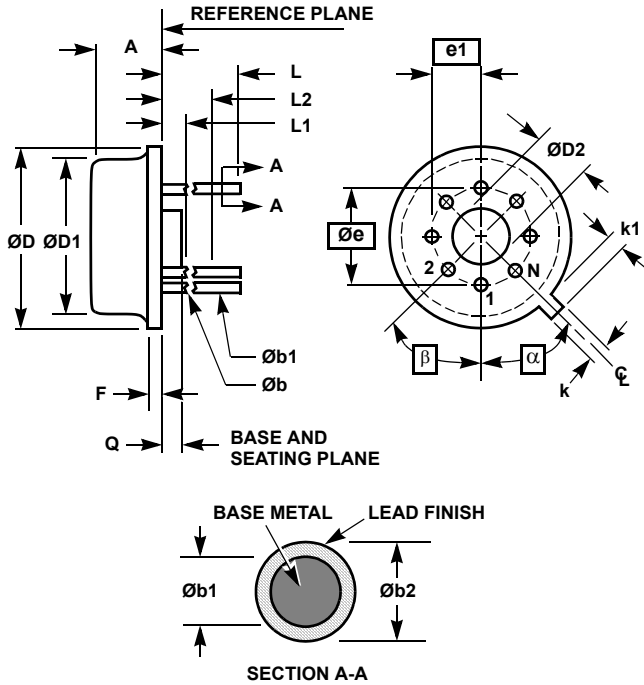

**T8.C MIL-STD-1835 MACY1-X8 (A1)
8 LEAD METAL CAN PACKAGE**

SYMBOL	INCHES		MILLIMETERS		NOTES
	MIN	MAX	MIN	MAX	
A	0.165	0.185	4.19	4.70	-
$\varnothing b$	0.016	0.019	0.41	0.48	1
$\varnothing b1$	0.016	0.021	0.41	0.53	1
$\varnothing b2$	0.016	0.024	0.41	0.61	-
$\varnothing D$	0.335	0.375	8.51	9.40	-
$\varnothing D1$	0.305	0.335	7.75	8.51	-
$\varnothing D2$	0.110	0.160	2.79	4.06	-
e	0.200 BSC		5.08 BSC		-
e1	0.100 BSC		2.54 BSC		-
F	-	0.040	-	1.02	-
k	0.027	0.034	0.69	0.86	-
k1	0.027	0.045	0.69	1.14	2
L	0.500	0.750	12.70	19.05	1
L1	-	0.050	-	1.27	1
L2	0.250	-	6.35	-	1
Q	0.010	0.045	0.25	1.14	-
α	45° BSC		45° BSC		3
β	45° BSC		45° BSC		3
N	8		8		4

Rev. 0 5/18/94

NOTES:

1. (All leads) $\varnothing b$ applies between L1 and L2. $\varnothing b1$ applies between L2 and 0.500 from the reference plane. Diameter is uncontrolled in L1 and beyond 0.500 from the reference plane.
2. Measured from maximum diameter of the product.
3. α is the basic spacing from the centerline of the tab to terminal 1 and β is the basic spacing of each lead or lead position ($N - 1$ places) from α , looking at the bottom of the package.
4. N is the maximum number of terminal positions.
5. Dimensioning and tolerancing per ANSI Y14.5M - 1982.
6. Controlling dimension: INCH.

Ceramic Dual-In-Line Frit Seal Packages (CERDIP)

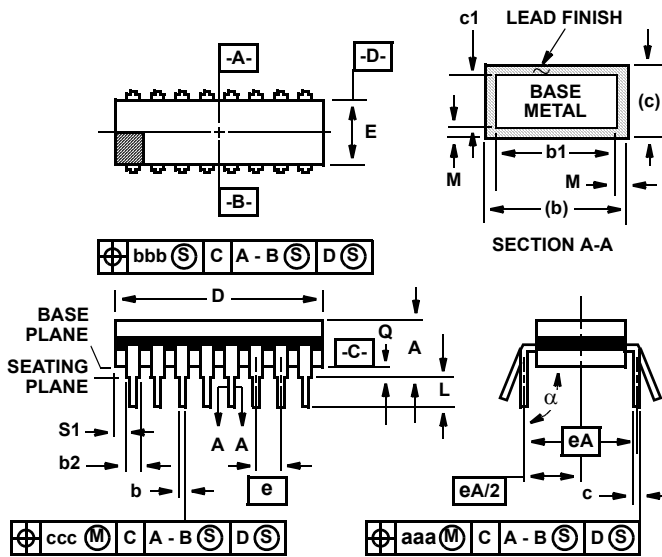

F8.3A MIL-STD-1835 GDIP1-T8 (D-4, CONFIGURATION A)
8 LEAD CERAMIC DUAL-IN-LINE FRIT SEAL PACKAGE

SYMBOL	INCHES		MILLIMETERS		NOTES
	MIN	MAX	MIN	MAX	
A	-	0.200	-	5.08	-
b	0.014	0.026	0.36	0.66	2
b1	0.014	0.023	0.36	0.58	3
b2	0.045	0.065	1.14	1.65	-
b3	0.023	0.045	0.58	1.14	4
c	0.008	0.018	0.20	0.46	2
c1	0.008	0.015	0.20	0.38	3
D	-	0.405	-	10.29	5
E	0.220	0.310	5.59	7.87	5
e	0.100 BSC		2.54 BSC		-
eA	0.300 BSC		7.62 BSC		-
eA/2	0.150 BSC		3.81 BSC		-
L	0.125	0.200	3.18	5.08	-
Q	0.015	0.060	0.38	1.52	6
S1	0.005	-	0.13	-	7
α	90°	105°	90°	105°	-
aaa	-	0.015	-	0.38	-
bbb	-	0.030	-	0.76	-
ccc	-	0.010	-	0.25	-
M	-	0.0015	-	0.038	2, 3
N	8		8		8

NOTES:

- Index area: A notch or a pin one identification mark shall be located adjacent to pin one and shall be located within the shaded area shown. The manufacturer's identification shall not be used as a pin one identification mark.
- The maximum limits of lead dimensions b and c or M shall be measured at the centroid of the finished lead surfaces, when solder dip or tin plate lead finish is applied.
- Dimensions b1 and c1 apply to lead base metal only. Dimension M applies to lead plating and finish thickness.
- Corner leads (1, N, N/2, and N/2+1) may be configured with a partial lead paddle. For this configuration dimension b3 replaces dimension b2.
- This dimension allows for off-center lid, meniscus, and glass overrun.
- Dimension Q shall be measured from the seating plane to the base plane.
- Measure dimension S1 at all four corners.
- N is the maximum number of terminal positions.
- Dimensioning and tolerancing per ANSI Y14.5M - 1982.
- Controlling dimension: INCH.

Rev. 0 4/94

All Intersil U.S. products are manufactured, assembled and tested utilizing ISO9000 quality systems. Intersil Corporation's quality certifications can be viewed at www.intersil.com/design/quality

Intersil products are sold by description only. Intersil Corporation reserves the right to make changes in circuit design, software and/or specifications at any time without notice. Accordingly, the reader is cautioned to verify that data sheets are current before placing orders. Information furnished by Intersil is believed to be accurate and reliable. However, no responsibility is assumed by Intersil or its subsidiaries for its use; nor for any infringements of patents or other rights of third parties which may result from its use. No license is granted by implication or otherwise under any patent or patent rights of Intersil or its subsidiaries.

For information regarding Intersil Corporation and its products, see www.intersil.com