

# 3SE International Limit Switches

## Position Switches

3SE2 100 to 3SE3 170 / 3SE2 303 / 3SE2 404  
Metal enclosure and open type

### Features

- UL Listed, CSA Certified, CE. Meets or exceeds most local, national and international standards.
- Standard (40 mm) or Wide (56 mm) die-cast aluminum housing. Offers increased wiring space, additional cable

entry options and corrosion resistant housing

- Standard (40 mm) offerings can accommodate both U.S. 29.4 [1.16] × 59.5 [2.34] and DIN 30 [1.18] × 60 [2.36] mounting dimensions

- Nine field interchangeable operating heads (12 variations). Interchangeable on both the standard (40 mm) and wide (56 mm) styles. Reduces inventory and inventory costs
- Field replaceable, electrically isolated, double bridge

contacts. Provides electrical flexibility and ease of maintenance

- Direct opening action (positive opening) of the NC contact
- NEMA A600, Q600 contact ratings

### Application

The function of position switches (limit switches) is to produce electrical signals corresponding to the positions of moving machinery.

The units are suitable for use in virtually any climate.

#### Specifications

IEC 60 947-5-1.

The 3SE2 100 and 3SE2 120 position switches correspond to Swiss regulations (SUVA). The following actuator types have been approved:

- Plunger – B
- Overtravel plunger – C
- Roller plunger – D
- Roller lever – E
- Angular roller lever – F
- Roller crank – GW

In addition, the open-type 3SE3 position switches and the 3SE3 switch inserts are also permitted.

#### Safety position switches

The 3SE position switches with metal enclosures and snap-action contacts as well as devices with slow-action contacts can be used as safety position switches in control systems conforming to EN 60 204-1, or IEC 60 204-1.

### Construction

3SE position switches are available in die-cast standard (40 mm) or wide (50 mm) aluminum enclosures or as open-type units.

The 3SE2 120/3SE3 170 position switches with standard enclosure, overtravel plunger, roller plunger, rod and roller crank actuators, conform to EN 50 041. These specifications define the most important mounting dimensions, operating points, enclosure types and actuator types.

Position switches have one or three cable entries. The cable entry has a 1/2"-NPT (3SE3) or M20 × 1.5 (3SE2) threaded metal wire opening. (see also [Accessories, Page 13/97](#))

#### Actuators

All actuators can be retro-fitted or exchanged for another version. They can also be repositioned every 90° so that the switches can be operated from any of the four sides.

- The position switches with roller lever are approached perpendicular to the plunger axis and position switches with angular roller lever are approached in parallel with the plunger axis.
- The roller crank actuators, adjustable-length roller crank actuators and rod actuators can be operated from both sides and be positioned from 10° to 10° on the actuating spindle. The rollers of the actuators are made from wear resistant plastic.

- The wobble spring can be approached from any direction.
- The forked lever actuator has two defined switching positions. The actuating element causes changeover from one position to the other. This actuator is suitable for two-channel operation.

The open-type 3SE position switches are available exclusively with a plunger actuator.

#### Important:

The 3SE position switches with metal enclosure are not permitted to be used as stops.

#### Contacts

The position switches (limit switches) are available with snap-action contacts, slow-action contacts or slow-action make-before-break contacts.

The 3SE position switches with a metal enclosure are available with 2, 3 or 4 contacts.

The movable normally closed and normally open switch contacts are electrically isolated from each other and are suitable for switching voltages of different potentials.

#### Contact reliability

The movable switch contacts are double moving contacts. This increases the contact reliability even when the switch has to be operated with low voltages and currents, e. g. DC 5 V/1 mA.

The switching point of the snap action contacts is independent of the switching speed.

The contact chamber is covered to prevent ingress of foreign bodies.

### Principle of operation

#### Positive opening →

The opening contacts of the switch are forced open mechanically, positively-driven and reliably by the plunger (positive-opening).

In order to ensure this positive opening, the position switch must be actuated in such a way that the nominal travel ([Pages 13/100 to 13/112](#)) and angle for the positive opening are substantially exceeded.

Position switches that display this symbol are suitable for use in safety applications.

# 3SE International Limit Switches

## Position Switches

**3SE2 100 to 3SE3 170 / 3SE2 303 / 3SE2 404**  
**Metal enclosure and open type, 40 and 56 mm width**

### Technical data

<ul style="list-style-type: none"> <li>• rated voltage</li> <li>• continuous current</li> <li>• switching capacity</li> <li>- for 3SE...-8.</li> </ul>	AC 600 V 10 A Heavy Duty, A 600/Q 600 Heavy Duty, A 300/Q 30																																				
Rated insulation voltage $U_i$ Pollution degree Short circuit protection <sup>1)</sup> , DIAZED-fuse links Rated operational voltage $U_e$	500 V Class 3 Utilization category gL/gG 6 A, quick response characteristic 10 A AC 500 V, over 300 V only for equal potential (3SE21.0-and 3SE3170-8..00) AC 500 V, over AC 380 V only for equal potential																																				
Conventional free-air thermal current $I_{th}$	10 A																																				
Rated operational current $I_e$ <sup>4)</sup>	AC 40 to 60 Hz DC																																				
	<table border="1"> <thead> <tr> <th><math>U_e</math> V</th> <th><math>I_e</math> / AC-12 A</th> <th><math>I_e</math> / AC-15 A</th> <th><math>U_e</math> V</th> <th><math>I_e</math> / DC-12 A</th> <th><math>I_e</math> / DC-13 A</th> </tr> </thead> <tbody> <tr> <td>24</td> <td>10</td> <td>10</td> <td>24</td> <td>10</td> <td>10</td> </tr> <tr> <td>125</td> <td>10</td> <td>10</td> <td>48</td> <td>6</td> <td>4</td> </tr> <tr> <td>230</td> <td>10</td> <td>6</td> <td>110</td> <td>4</td> <td>1</td> </tr> <tr> <td>400</td> <td>10</td> <td>4</td> <td>220</td> <td>1</td> <td>0.4<sup>2)</sup></td> </tr> <tr> <td>500</td> <td>10</td> <td>3</td> <td>440</td> <td>0.5</td> <td>0.2<sup>3)</sup></td> </tr> </tbody> </table>	$U_e$ V	$I_e$ / AC-12 A	$I_e$ / AC-15 A	$U_e$ V	$I_e$ / DC-12 A	$I_e$ / DC-13 A	24	10	10	24	10	10	125	10	10	48	6	4	230	10	6	110	4	1	400	10	4	220	1	0.4 <sup>2)</sup>	500	10	3	440	0.5	0.2 <sup>3)</sup>
$U_e$ V	$I_e$ / AC-12 A	$I_e$ / AC-15 A	$U_e$ V	$I_e$ / DC-12 A	$I_e$ / DC-13 A																																
24	10	10	24	10	10																																
125	10	10	48	6	4																																
230	10	6	110	4	1																																
400	10	4	220	1	0.4 <sup>2)</sup>																																
500	10	3	440	0.5	0.2 <sup>3)</sup>																																
Mechanical endurance Electrical endurance	30 × 10 <sup>6</sup> operating cycles (15 × 10 <sup>6</sup> for 3SE3 2.0-8.) 10 × 10 <sup>6</sup> operating cycles with 3RH11, 3RT10 16, 3RT10 17, 3RT10 24 to 3RT10 26 (3TH4, 3TF40 to 3TF43) contactors 0.5 × 10 <sup>6</sup> operating cycles when interrupting $I_e$ / AC-15 at 230 V With DC the contact endurance depends not only on the breaking current but also on the voltage, the circuit inductance and the speed of switching. No generally valid information can be given.																																				
<ul style="list-style-type: none"> <li>• for AC-15 duty</li> <li>• for DC-13 duty</li> </ul>																																					
Operating frequency	6 × 10 <sup>3</sup> operating cycles per hour with 3RH11, 3RT10 16, 3RT10 17, 3RT10 24 to 3RT10 26 (3TH4, 3TF40 to 3TF43) contactors																																				
Operating accuracy	0.05 mm for repeated switching, measured at the plunger of the switch block.																																				
Operating point	With snap-action contacts independent of contact wear constant throughout the life of the switch																																				
Ambient temperature Degree of protection DIN VDE 0470 and IEC 60 529	-30 to +85 °C (-22 to +185°F)																																				
<ul style="list-style-type: none"> <li>• with metal enclosure</li> <li>• open-type</li> <li>• electrical plug and socket connection</li> </ul>	IP 67 IP 20 (terminals), IP 40 (switching chamber) IP 65																																				
Enclosure cable entry Conductor cross-sections	1 × 1/2"-NPT (3SE3); 1 × M 20 × 1.5 (3SE212) or 3 × M20 × 1.5 (3SE2100, 2303, 2404)																																				
<ul style="list-style-type: none"> <li>• solid</li> <li>• finely stranded with end sleeve</li> </ul>	2 × 2.5 mm <sup>2</sup> (2 × 14 AWG) 2 × 1.5 mm <sup>2</sup> (2 × 16 AWG)																																				
Installation angle Enclosure material Protective conductor terminal	Any Metal (GD – AISi 12) M 3.5 inside enclosure																																				

1) Without any welding acc. to DIN VDE 0660 Part 200.

2) 3SE21.0 - and 3SE3170 - 8..00: 0.27A

3) 3SE21.0 - and 3SE3170 - 8..00: 0.10A

4) Refer to Section 19, General Information for NEMA Control and Circuit Ratings.







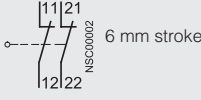

# 3SE International Limit Switches

## Position Switches

3SE2 100 to 3SE3 170  
Metal enclosure, 40 and 56 mm width

### Selection and ordering data

2 contacts · Moving double break contacts · IP 67 degree of protection · EN 50 041

40 mm wide	56 mm wide <sup>2)</sup>	Actuator design to EN 50 041	Enclosure width	3SE. position switches with 2 slow-action contacts	3SE. position switches with 2 slow-action contacts	Weight approx.		
				with 2 slow-action contacts	with 2 slow-action contacts			
				 6 mm stroke Identification number <b>11</b> acc. to EN 50 013, switch block 3SE3 000-0A	 6 mm stroke Identification number <b>02</b> acc. to EN 50 013, switch block 3SE3 000-6A			
				Order No.	List Price \$	Order No.	List Price \$	kg
				1 unit	1 unit	1 unit	1 unit	
	Actuator <sup>1)</sup>		mm					
	<b>Plunger</b> (3SX3100)	–	40 56	→ 3SE□ 1□0-0B → 3SE2 100-0B	50.00 50.00	→ 3SE□ 1□0-6B → 3SE2 100-6B	50.00 50.00	0.190 0.220
	<b>Overtravel plunger</b> (3SX3106)	B	40 56	→ 3SE□ 1□0-0C → 3SE2 100-0C	67.00 67.00	→ 3SE□ 1□0-6C → 3SE2 100-6C	67.00 67.00	0.230 0.258
	<b>Roller plunger</b> (3SX3107)	C	40 56	→ 3SE□ 1□0-0D → 3SE2 100-0D	74.00 74.00	→ 3SE□ 1□0-6D → 3SE2 100-6D	74.00 74.00	0.250 0.280
	<b>Roller lever</b> Actuator made of molded plastic (3SX3102)	–	40 56	→ 3SE□ 1□0-0E → 3SE2 100-0E	63.00 63.00	→ 3SE□ 1□0-6E → 3SE2 100-6E	63.00 63.00	0.210 0.240
	<b>Angular roller lever</b> Actuator made of molded plastic (3SX3104)	–	40 56	→ 3SE□ 1□0-0F → 3SE2 100-0F	60.00 60.00	→ 3SE□ 1□0-6F → 3SE2 100-6F	60.00 60.00	0.225 0.240
	<b>Roller crank</b> • finely adjustable from 10° to 10° (3SX3211 + 3SX3212) • adjustable length, finely – adjustable from 10° to 10° (3SX3211 + 3SX3213)	A	40 56 40 56	→ 3SE□ 1□0-0GW → 3SE2 100-0GW 3SE□ 1□0-0UW 3SE2 100-0UW	71.00 71.00 87.00 87.00	→ 3SE□ 1□0-6GW → 3SE2 100-6GW 3SE□ 1□0-6UW 3SE2 100-6UW	71.00 71.00 87.00 87.00	0.305 0.335 0.315 0.333
	<b>Rod actuator</b> finely adjustable from 10° to 10° • Molded plastic rod (3SX3211 + 3SX3215) • Aluminum rod (3SX3211 + 3SX3214)	D	40 56 40 56	3SE□ 1□0-0WW 3SE2 100-0WW 3SE□ 1□0-0VW 3SE2 100-0VW	82.00 82.00 83.00 83.00	3SE□ 1□0-6WW 3SE2 100-6WW 3SE□ 1□0-6VW 3SE2 100-6VW	82.00 83.00 83.00 83.00	0.315 0.348 0.321 0.354
	<b>Switch body</b> with switch block without actuator		40 56	3SE□ 1□0-0A 3SE2 100-0A	44.00 44.00	3SE□ 1□0-6A 3SE2 100-6A	44.00 44.00	0.175 0.203

#### Order No. suffix

- with metric connecting thread M 20 × 1.5  
I.E. 3SE□1 □0
- with 1/2" - NPT connecting thread  
I.E. 3SE□1 □0

2.2

3.7

2.2

3.7

For operation, operating speed and travel, see Pages 13/100 to 13/105.

→ Positive opening acc. to IEC 60 947-5-1, Appendix K, and DIN VDE 0660 Part 200.

1) The actuator heads can be subsequently exchanged (see Page 13/95).  
2) For conduit thread adaptors see page 13/97.











# 3SE International Limit Switches

## Position Switches

**3SE2 100 to 3SE3 170**  
Metal enclosure, 40 and 56 mm width

### Selection and ordering data

**2 contacts · Moving double break contacts · IP 67 degree of protection · EN 50 041**

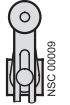
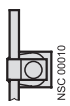
40 mm wide	56 mm wide <sup>2)</sup>	Actuator design to EN 50 041	Enclosure width	3SE. position switches with 2 slow-action contacts	3SE. position switches with 2 slow-action make before-break contacts	Weight approx.		
				 <p>6 mm stroke NSC00003</p> <p>Identification number <b>20</b> acc. to EN 50 013, switch block 3SE3 000-7A</p>	 <p>6 mm stroke NSC00014</p> <p>Identification number <b>11</b> acc. to EN 50 013, switch block 3SE3 000-3A</p>			
Actuator <sup>1)</sup>			mm	Order No.	List Price \$ 1 unit	Order No.	List Price \$ 1 unit	kg
 NSC00096	<b>Plunger</b> (3SX3100)	–	40 56	<b>3SE□ 1□0-7B</b> 50.00 <b>3SE2 100-7B</b> 50.00		<b>3SE□ 1□0-3B</b> 50.00 <b>3SE2 100-3B</b> 50.00		0.195 0.220
 NSC00097	<b>Overtravel plunger</b> (3SX3106)	B	40 56	<b>3SE□ 1□0-7C</b> 67.00 <b>3SE2 100-7C</b> 67.00		<b>3SE□ 1□0-3C</b> 67.00 <b>3SE2 100-3C</b> 67.00		0.230 0.259
 NSC 00088	<b>Roller plunger</b> (3SX3107)	C	40 56	<b>3SE□ 1□0-7D</b> 74.00 <b>3SE2 100-7D</b> 74.00		<b>3SE□ 1□0-3D</b> 74.00 <b>3SE2 100-3D</b> 74.00		0.252 0.277
 ISC 00089	<b>Roller lever</b> Actuator made of molded plastic (3SX3102)	–	40 56	<b>3SE□ 1□0-7E</b> 63.00 <b>3SE2 100-7E</b> 63.00		<b>3SE□ 1□0-3E</b> 63.00 <b>3SE2 100-3E</b> 63.00		0.209 0.239
 NSC00093	<b>Angular roller lever</b> Actuator made of molded plastic (3SX3104)	–	40 56	<b>3SE□ 1□0-7F</b> 60.00 <b>3SE2 100-7F</b> 60.00		<b>3SE□ 1□0-3F</b> 60.00 <b>3SE2 100-3F</b> 60.00		0.220 0.236
 NSC 00094	<b>Roller crank</b> • finely adjustable from 10° to 10° (3SX3211 + 3SX3212)	A	40 56	<b>3SE□ 1□0-7GW</b> 75.00 <b>3SE2 100-7GW</b> 71.00		<b>3SE□ 1□0-3GW</b> 71.00 <b>3SE2 100-3GW</b> 71.00		0.305 0.328
 NSC 00089	• adjustable length, finely – adjustable from 10° to 10° (3SX3211 + 3SX3213)		40 56	<b>3SE□ 1□0-7UW</b> 87.00 <b>3SE2 100-7UW</b> 87.00		<b>3SE□ 1□0-3UW</b> 87.00 <b>3SE2 100-3UW</b> 87.00		0.315 0.336
 NSC 00010	<b>Rod actuator</b> finely adjustable from 10° to 10° • Molded plastic rod (3SX3211 + 3SX3215) • Aluminum rod (3SX3211 + 3SX3214)	D	40 56 40 56	<b>3SE□ 1□0-7WW</b> 82.00 <b>3SE2 100-7WW</b> 83.00 <b>3SE□ 1□0-7VW</b> 83.00 <b>3SE2 100-7VW</b> 83.00		<b>3SE□ 1□0-3WW</b> 82.00 <b>3SE2 100-3WW</b> 83.00 <b>3SE□ 1□0-3VW</b> 83.00 <b>3SE2 100-3VW</b> 83.00		0.190 0.200 0.190 0.200
	<b>Switch body</b> with switch block without actuator		40 56	<b>3SE□ 1□0-7A</b> 44.00 <b>3SE2 100-7A</b> 44.00		<b>3SE□ 1□0-3A</b> 44.00 <b>3SE2 100-3A</b> 44.00		0.175 0.203

#### Order No. suffix

- with metric connecting thread M 20 × 1.5  
I.E. 3SE□1 □0
- with 1/2" - NPT connecting thread  
I.E. 3SE□1 □0

2 . 2  
3 . 7

2 . 2  
3 . 7

For operation, operating speed and travel, see Pages 13/100 to 13/105.

➔ Positive opening acc. to IEC 60 947-5-1, Appendix K, and DIN VDE 0660 Part 200.

1) The actuator heads can be subsequently exchanged (see Page 13/95).  
2) For conduit thread adaptors see page 13/97.





# 3SE International Limit Switches

## Position Switches

**3SE2120 Specials**  
Metal enclosure, 40 and 56mm width

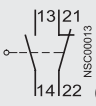
### Selection and ordering data

**2 contacts · Moving double break contacts · IP 67 degree of protection · EN 50 041**

40 mm wide	56 mm wide <sup>2)</sup>	Actuator design to EN 50 041	Enclosure width	3SE. position switches with 2 snap-action contacts	3SE3 position switches with 2 snap-action contacts	Weight approx.			
				 Identification number <b>11</b> acc. to EN 50 013, switch block 3SE3 000-1A <sup>2)</sup>	 Identification number <b>02</b> acc. to EN 50 013 switch block 3SE3 000-8AV00 <sup>2)</sup>				
				Order No.	List Price \$	Order No.	List Price \$		
		Actuator <sup>1)</sup>	mm		1 unit		1 unit	kg	
									
		<b>Plunger</b> (3SX3100)	–	40 56	→ <b>3SE□ 1□0-1B</b> → <b>3SE2 100-1B</b>	<b>50.00</b> <b>50.00</b>	→ <b>3SE□ 1□0-8BV00</b> → <b>3SE2 100-8BV00</b>	<b>50.00</b> <b>50.00</b>	0.190 0.225
		<b>Overtravel plunger</b> (3SX3106)	B	40 56	→ <b>3SE□ 1□0-1C</b> → <b>3SE2 100-1C</b>	<b>67.00</b> <b>67.00</b>	→ <b>3SE□ 1□0-8CV00</b> → <b>3SE2 100-8CV00</b>	<b>67.00</b> <b>67.00</b>	0.230 0.260
		<b>Roller plunger</b> (3SX3107)	C	40 56	→ <b>3SE□ 1□0-1D</b> → <b>3SE2 100-1D</b>	<b>74.00</b> <b>74.00</b>	→ <b>3SE□ 1□0-8DV00</b> → <b>3SE2 100-8DV00</b>	<b>74.00</b> <b>74.00</b>	0.255 0.279
		<b>Roller lever</b> Actuator made of molded plastic (3SX3102)	–	40 56	→ <b>3SE□ 1□0-1E</b> → <b>3SE2 100-1E</b>	<b>63.00</b> <b>63.00</b>	→ <b>3SE□ 1□0-8EV00</b> → <b>3SE2 100-8EV00</b>	<b>63.00</b> <b>63.00</b>	0.210 0.239
		<b>Angular roller lever</b> Actuator made of molded plastic (3SX3104)	–	40 56	→ <b>3SE□ 1□0-1F</b> → <b>3SE2 100-1F</b>	<b>60.00</b> <b>60.00</b>	→ <b>3SE□ 1□0-8FV00</b> → <b>3SE2 100-8FV00</b>	<b>60.00</b> <b>60.00</b>	0.225 0.242
		<b>Roller crank</b> • finely adjustable from 10° to 10° (3SX3211 + 3SX3212)	A	40 56	→ <b>3SE□ 1□0-1GW</b> → <b>3SE2 100-1GW</b>	<b>71.00</b> <b>71.00</b>	→ <b>3SE□ 1□0-8GW00</b> → <b>3SE2 100-8GW00</b>	<b>71.00</b> <b>71.00</b>	0.305 0.331
		• adjustable length, finely adjustable from 10° to 10° (3SX3211 + 3SX3213)	–	40 56	<b>3SE□ 1□0-1UW</b> <b>3SE2 100-1UW</b>	<b>87.00</b> <b>87.00</b>	<b>3SE□ 1□0-8UW00</b> <b>3SE2 100-8UW00</b>	<b>87.00</b> <b>87.00</b>	0.315 0.336
		<b>Rod actuator</b> finely adjustable from 10° to 10°	D						
		• Molded plastic rod (3SX3211 + 3SX3215)		40 56	<b>3SE□ 1□0-1WW</b> <b>3SE2 100-1WW</b>	<b>82.00</b> <b>82.00</b>	<b>3SE□ 1□0-8WW00</b> <b>3SE2 100-8WW00</b>	<b>82.00</b> <b>82.00</b>	0.315 0.346
		• Aluminum rod (3SX3211 + 3SX3214)		40 56	<b>3SE□ 1□0-1VW</b> <b>3SE2 100-1VW</b>	<b>83.00</b> <b>83.00</b>	<b>3SE□ 1□0-8VW00</b> <b>3SE2 100-8VW00</b>	<b>83.00</b> <b>83.00</b>	0.320 0.355
		<b>Wobble spring</b> (3SX3126)	–	40 56	<b>3SE□ 1□0-1R</b> <b>3SE2 100-1R</b>	<b>81.00</b> <b>81.00</b>	<b>3SE□ 1□0-8RV00</b> <b>3SE2 100-8RV00</b>	<b>81.00</b> <b>81.00</b>	0.230 0.270
		<b>Fork lever, latching</b> (3SX3127 + 3SX3115)	–	40 56	<b>3SE□ 1□0-1T</b> <b>3SE2 100-1T</b>	<b>117.00</b> <b>117.00</b>	– –		0.340 0.360
		<b>Switch body</b> with switch block without actuator		40 56	<b>3SE□ 1□0-1A</b> <b>3SE2 100-1A</b>	<b>44.00</b> <b>44.00</b>	<b>3SE□ 1□0-8AV00</b> <b>3SE3 100-8AV00</b>	<b>44.00</b> <b>44.00</b>	0.175 0.203

#### Order No. suffix

- with metric connecting thread M 20 x 1.5  
I.E. 3SE□1□0
- with 1/2" - NPT connecting thread  
I.E. 3SE□1□7

2.2

3.7

2.2

3.7

For operation, operating speed and travel, see Pages 13/100 to 13/105.

- Positive opening acc. to IEC 60 947-5-1, Appendix K, and DIN VDE 0660 Part 200.

- 1) The actuator heads can be subsequently exchanged (see Page 13/95).
- 2) For conduit thread adaptors see page 13/97.

# 3SE International Limit Switches

## Position Switches

**3SE2120 Specials**  
Metal enclosure, 40mm width

### Selection and ordering data

2 contacts · Moving double break contacts · IP 67 degree of protection · EN 50 041 · with 4-pole or 5-pole male receptacle

40 mm wide



Actuator design to EN 50 041

Enclosure width

**3SE3 position switches**  
with 2 snap-action contacts

Weight approx.

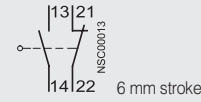

Identification number 11 acc. to EN 50 013, switch block 3SE3 000-1A)

www.DataSheet4U.com

	Actuator 1)	mm	Order No.	List Price \$ 1 unit	kg
<p><b>Plunger</b></p> <ul style="list-style-type: none"> <li>with 4-pole, M12 male receptacle</li> <li>with 5-pole, M12 male receptacle</li> </ul>	-	40	→ <b>3SE2 120-1BV00-0AC4</b>	<b>67.00</b>	0.200
			→ <b>3SE2 120-1BV00-0AC5</b>	<b>70.00</b>	0.200
<p><b>Overtravel plunger</b></p> <ul style="list-style-type: none"> <li>with 4-pole, M12 male receptacle</li> <li>with 5-pole, M12 male receptacle</li> </ul>	B	40	→ <b>3SE2 120-1CV00-0AC4</b>	<b>84.00</b>	0.200
			→ <b>3SE2 120-1CV00-0AC5</b>	<b>87.00</b>	0.200
<p><b>Roller plunger</b></p> <ul style="list-style-type: none"> <li>with 4-pole, M12 male receptacle</li> <li>with 5-pole, M12 male receptacle</li> </ul>	C	40	→ <b>3SE2 120-1DV00-0AC4</b>	<b>91.00</b>	0.265
			→ <b>3SE2 120-1DV00-0AC5</b>	<b>94.00</b>	0.265
<p><b>Roller lever</b></p> <ul style="list-style-type: none"> <li>with 4-pole, M12 male receptacle</li> <li>with 5-pole, M12 male receptacle</li> </ul>	-	40	→ <b>3SE2 120-1EV00-0AC4</b>	<b>80.00</b>	0.225
			→ <b>3SE2 120-1EV00-0AC5</b>	<b>83.00</b>	0.200
<p><b>Angular roller lever</b></p> <ul style="list-style-type: none"> <li>with 4-pole, M12 male receptacle</li> <li>with 5-pole, M12 male receptacle</li> </ul>	-	40	→ <b>3SE2 120-1FV00-0AC4</b>	<b>67.00</b>	0.230
			→ <b>3SE2 120-1FV00-0AC5</b>	<b>70.00</b>	0.230
<p><b>Roller crank</b></p> <ul style="list-style-type: none"> <li><b>finely adjustable from 10° to 10°</b> <ul style="list-style-type: none"> <li>with 4-pole, M12 male receptacle</li> <li>with 5-pole, M12 male receptacle</li> </ul> </li> <li><b>adjustable length, finely adjustable from 10° to 10°</b> <ul style="list-style-type: none"> <li>with 4-pole, M12 male receptacle</li> <li>with 5-pole, M12 male receptacle</li> </ul> </li> </ul>	A	40	→ <b>3SE2 120-1GW00-0AC4</b>	<b>88.00</b>	0.310
			→ <b>3SE2 120-1GW00-0AC5</b>	<b>91.00</b>	0.310
			<b>3SE2 120-1UW00-0AC4</b>	<b>104.00</b>	0.325
<p><b>Switch body with contact block without operating head</b></p> <ul style="list-style-type: none"> <li>with 4-pole, M12 male receptacle</li> <li>with 5-pole, M12 male receptacle</li> </ul>	-	40	<b>3SE2 120-1AV00-0AC4</b>	<b>61.00</b>	0.180
			<b>3SE2 120-1AV00-0AC5</b>	<b>64.00</b>	0.180

### Wiring Diagram for M12 Connections

M12 Pin	Limit Switch, Snap-Action Contacts 2)		Typical M12 Cable 3)	
	4-pole Connection	5-pole Connection	4-wire Connection	5-wire Connection
1	21	21	Brown	Brown
2	22	22	White	White
3	13	13	Blue	Blue
4	14	14	Black	Black
5	N/A	Ground	N/A	Green



4-pole 5-pole  
Male Receptacle

→ Positive opening acc. to IEC 60 947-5-1, Appendix K

1) The actuator heads can be subsequently exchanged (see Page 13/95).  
2) 21 & 22 = Normally Closed; 13 & 14 = Normally Open.

3) Typical M12 female plug with 5 meter cable.  
4-pole 5-pole  
Right-angle 3RX1542 3RX1631  
Straight 3RX1513 3RX1570













# 3SE International Limit Switches

## Position Switches

**3SE2 120 Specials**  
Metal enclosure, 40 and 56 mm width

### Selection and ordering data

2 contacts · Moving double break contacts · IP 67 degree of protection · EN 50 041  
1 or 2 LEDs · Stainless steel roller/rod · Increased corrosion protection

40 mm wide <sup>2)</sup>	Actuator design to EN 50 041	Enclosure width	3SE3 position switches with 2 snap-action contacts	Weight approx.
			 6 mm stroke Identification number 11 acc. to EN 50 013 switch block 3SE3 000-8AV00 <sup>2)</sup>	
Actuator <sup>1)</sup>	mm	Order No.	List Price \$ 1 unit	kg
	–	40	→ 3SE2120-1AV00-0AF0 + 3SX3100 <sup>5)</sup> → 3SE2 120-1BV00-0AK0 <b>52.00</b>	0.220 0.200
	B	40	→ 3SE2120-1AV00-0AF0 + 3SX3106 <sup>5)</sup> → 3SE2 120-1CV00-0AK0 <b>69.00</b>	0.260 0.240
	C	40	→ 3SE2120-1DV00-0AF0 <b>99.00</b> → 3SE2120-1DV00-0AF1 <b>108.00</b> → 3SE2120-1DV00-0AA3 <b>92.00</b> → 3SE2120-1DV00-0AK0 <b>76.00</b>	0.250 0.250 0.255 0.250
	–	40	→ 3SE2120-1EV00-0AF0 <b>88.00</b> → 3SE2120-1EV00-0AA3 <b>85.00</b> → 3SE2120-1EV00-0AK0 <b>65.00</b>	0.215 0.200 0.210
	–	40	→ - → 3SE2120-1FV00-0AA3 <b>82.00</b> → 3SE2120-1FV00-0AK0 <b>62.00</b>	0.240 0.210
	A	40	→ 3SE2120-1GW00-0AF0 <b>96.00</b> → 3SE2120-1GW00-0AA3 <b>93.00</b> → 3SE2120-1GW00-0AK0 <b>73.00</b>	0.305 0.315 0.310
			3SE2120-1UW00-0AF0 <b>112.00</b> 3SE2120-1UW00-0AA3 <b>109.00</b> 3SE2120-1UW00-0AK0 <b>89.00</b>	0.310 0.315 0.315
	D	40	- 3SE2120-1WW00-0AK0 <b>84.00</b> - 3SE2120-1VW00-0AK0 <b>85.00</b>	0.315 0.320
	–	40	- 3SE2120-1RV00-0AL0 <b>78.00</b> 3SE2120-1RV00-0AK0 <b>83.00</b>	0.200 0.200
	–	40	- 3SE2120-1TV00-0AA3 <b>220.00</b> 3SE2120-1TV00-0AK0 <b>119.00</b>	0.355 0.345
	–	40	3SE2120-1AV00-0AF0 <b>69.00</b> 3SE2120-1AV00-0AF1 <b>78.00</b>	0.185 0.200

→ Positive opening acc. to IEC 60 947-5-1, Appendix K

1) The actuator heads can be subsequently exchanged (see Page 13/95).

2) For conduit thread adaptors see page 13/97.

3) The switch contacts have changed from their normal state.

4) Green LED – There is power to the switch. Yellow LED – The switch contacts have changed from their normal state.

5) Two parts required. Order separately.

# 3SE International Limit Switches

## Position Switches

3SE2 100 to 3SE3 170, 3SE2 230

### Selection and ordering data

#### Switch Bodies with replaceable contact block without operating head

Metal Housing  
40 mm<sup>1)</sup>



**3SE2 120**  
**3SE3 170**

56 mm<sup>1)</sup>



**3SE2 100**

Molded Plastic Housing  
40 mm<sup>2)</sup>



**3SE2 230**

www.DataSheet4U.com

3SE2100, 3SE2120, 3SE2230 and 3SE3170 limit switches with field replaceable contact blocks may be provided as complete devices; or, separately as components; switch body, operating head and lever (if applicable).

**Switch Bodies** are complete except for the operating head and lever (if applicable). The contact blocks are field replaceable and have a molded plastic housing in which the fixed contacts and the terminals are located.

**Operating Heads** include the necessary hardware to mount to the selected Switch Body and may require an **Operating Lever**.

Plunger, Overtravel Plunger, Roller Plunger, Roller Lever, Angular Roller Lever and Wobble Spring operating heads are complete so only a Switch Body is required.

Side rotary operating heads such as Roller Crank, Adjustable Roller Crank, Fork Lever and Rod Actuator require a side rotary Operating Head and a suitable Lever. Therefore three parts are required for a complete switch; Switch Body, Operating Head, suitable Lever.

Operating heads for the 3SE2100, 3SE2120 and 3SE3170 series are interchangeable with each other and the various contact configurations. The same operating heads are also used in the 3SE2303 and 3SE2404 series. These switches are not available in parts.

Operating heads for the 3SE2230 series are interchangeable with the various contact configurations and may also require a lever (side rotary operating head).

#### Switch Body with Contact Block without Operating Head

Housing Style	Contact Arrangement																	
	1 NO + 1 NC Slow-action			1 NO + 1 NC Snap-action			1 NO + 1 NC, Slow-action Make-Before-Break			2 NC Slow-action			2 NO Slow-action			2 NC Snap-action		
	Order No.	List Price \$ 1 Unit	Weight Approx. kg	Order No.	List Price \$ 1 Unit	Weight Approx. kg	Order No.	List Price \$ 1 Unit	Weight Approx. kg	Order No.	List Price \$ 1 Unit	Weight Approx. kg	Order No.	List Price \$ 1 Unit	Weight Approx. kg	Order No.	List Price \$ 1 Unit	Weight Approx. kg
56 mm Wide Metal Housing with M20 x 1.5 Threaded Opening																		
	3SE2100-0A	44.00	0.202	3SE2100-1A	44.00	0.203	3SE2100-3A	44.00	0.205	3SE2100-6A	44.00	0.200	3SE2100-7A	44.00	0.203	3SE2100-8AV00	44.00	0.175
40 mm Wide Metal Housing with M20 x 1.5 Threaded Opening																		
	3SE2120-0A	44.00	0.175	3SE2120-1A	44.00	0.175	3SE2120-3A	44.00	0.175	3SE2120-6A	44.00	0.175	3SE2120-7A	44.00	0.190	3SE2120-8AV00	44.00	0.175
40 mm Wide Metal Housing with M20 x 1.5 Threaded Opening and One 24V LED																		
	—	—	—	3SE2120-1AV00-0AF0	69.00	0.185	—	—	—	—	—	—	—	—	—	—	—	—
40 mm Wide Metal Housing with M20 x 1.5 Threaded Opening and Two 24V LEDs																		
	—	—	—	3SE2120-1AV00-0AF1	78.00	0.200	—	—	—	—	—	—	—	—	—	—	—	—
40 mm Wide Metal Housing with M12 male Receptacle, 4-Poles																		
	—	—	—	3SE2120-1AV00-0AC4	61.00	0.180	—	—	—	—	—	—	—	—	—	—	—	—
40 mm Wide Metal Housing with M12 male Receptacle, 5-Poles																		
	—	—	—	3SE2120-1AV00-0AC5	64.00	0.180	—	—	—	—	—	—	—	—	—	—	—	—
40 mm Wide Metal Housing with 1/2" NPT Threaded Opening																		
	3SE3170-0A	44.00	0.171	3SE3170-1A	44.00	0.169	3SE3170-3A	44.00	0.182	3SE3170-6A	44.00	0.174	3SE3170-7A	44.00	0.170	3SE3170-8AV00	44.00	0.170
40 mm Wide Plastic Housing with M20 x 1.5 Threaded Opening																		
	3SE2230-0A	31.00	0.095	3SE2230-1A	31.00	0.100	3SE2230-3A	31.00	0.095	3SE2230-6A	31.00	0.095	3SE2230-7A	31.00	0.095	3SE2230-8AV00	31.00	0.130

<sup>1)</sup> Shown with operating head. See catalog page 13/95 and 13/96 for operating heads and levers.

<sup>2)</sup> Shown with operating head. See catalog page 13/83 for operating heads and levers.









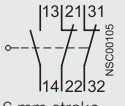
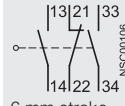
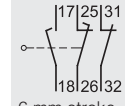
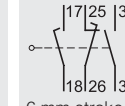

# 3SE International Limit Switches

## Position Switches

**3SE2 303**  
Metal enclosure, 56 mm width

### Selection and ordering data

3 contacts · Wide enclosure · Moving double break contacts · IP 67 degree of protection · M20 x 1.5 connecting thread

56 mm wide <sup>2)</sup>		3SE. position switches with mit 3 slow-action contacts	3SE. position switches with mit 3 slow-action contacts	3SE. position switches with 3 slow-action make- before-break contacts	3SE. position switches with 3 slow-action make-before-break contacts	Wght approx.	
		 6 mm stroke Identification number <b>12</b> acc. to EN 50 013, switch block 3SE3 003-0A	 6 mm stroke Identification number <b>21</b> acc. to EN 50 013, switch block 3SE3 003-1A	 6 mm stroke Identification number <b>12</b> acc. to EN 50 013, switch block 3SE3 003-2A	 6 mm stroke Identification No. <b>21</b> acc. to EN 50 013, switch block 3SE3 003-3A		
		Order No.	Order No.	Order No.	Order No.	List Price \$ 1 unit	
Actuator <sup>1)</sup>						kg	
	<b>Plunger</b> (3SX3100)	→ 3SE2 303-0B	→ 3SE2 303-1B	→ 3SE2 303-2B	→ 3SE2 303-3B	99.00	0.310
	<b>Overtravel plunger</b> (3SX3106)	→ 3SE2 303-0C	→ 3SE2 303-1C	→ 3SE2 303-2C	→ 3SE2 303-3C	94.00	0.332
	<b>Roller plunger</b> (3SX3107)	→ 3SE2 303-0D	→ 3SE2 303-1D	→ 3SE2 303-2D	→ 3SE2 303-3D	102.00	0.356
	<b>Roller lever</b> Actuator made of molded plastic (3SX3102)	→ 3SE2 303-0E	→ 3SE2 303-1E	→ 3SE2 303-2E	→ 3SE2 303-3E	91.00	0.314
	<b>Angular roller lever</b> Actuator made of molded plastic (3SX3104)	→ 3SE2 303-0F	→ 3SE2 303-1F	→ 3SE2 303-2F	→ 3SE2 303-3F	87.00	0.330
	<b>Roller crank</b> • finely adjustable from 10° to 10° (3SX3211 + 3SX3212)	→ 3SE2 303-0GW	→ 3SE2 303-1GW	→ 3SE2 303-2GW	→ 3SE2 303-3GW	98.00	0.411
	• adjustable length, finely adjustable from 10° to 10° (3SX3211 + 3SX3213)	3SE2 303-0UW	3SE2 303-1UW	3SE2 303-2UW	3SE2 303-3UW	114.00	0.415
	<b>Rod actuator</b> finely adjustable from 10° to 10° • Molded plastic rod (3SX3211 + 3SX3215)	3SE2 303-0WW	3SE2 303-1WW	3SE2 303-2WW	3SE2 303-3WW	111.00	0.416
	• Aluminum rod (3SX3211 + 3SX3214)	3SE2 303-0VW	3SE2 303-1VW	3SE2 303-2VW	3SE2 303-3VW	111.00	0.425

For operation, operating speed and travel, see Pages 13/106 to 13/112.

→ Positive opening acc. to IEC 60 947-5-1, Appendix K, and DIN VDE 0660 Part 200.

1) The actuator heads can be subsequently exchanged (see page 13/95).  
2) For conduit thread adaptors see page 13/97.

1  
2  
3  
4  
5  
6  
7  
8  
9  
10  
11  
12  
13









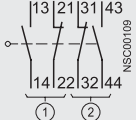
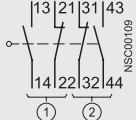
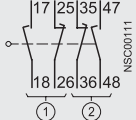

# 3SE International Limit Switches

## Position Switches

**3SE2 404**  
Metal enclosure, 56 mm width

### Selection and ordering data

4 contacts · Wide enclosure · Moving double-break contacts · Degree of protection IP 67 · M20 x 1.5 connecting thread

56 mm wide <sup>2)</sup>	3SE. position switches with 4 snap-action contacts		3SE. position switches with 4 slow-action contacts		3SE. position switches with 4 slow-action make before-break contacts		Wght approx.
	Order No.	List Price \$ 1 unit	Order No.	List Price \$ 1 unit	Order No.	List Price \$ 1 unit	
							
	 6 mm stroke Identification number <b>22</b> acc. to EN 50 013 ① Switch block 3SE3 000-1A ② Switch block 3SE3 010-1A		 6 mm stroke Identification number <b>22</b> acc. to EN 50 013 ① Switch block 3SE3 000-0A ② Switch block 3SE3 010-0A		 6 mm stroke Identification number <b>22</b> acc. to EN 50 013 ① Switch block 3SE3 000-3A ② Switch block 3SE3 010-3A		
Actuator <sup>1)</sup>							kg
	<b>Plunger</b> (3SX3100)	→ <b>3SE2 404-1B</b> 121.00	→ <b>3SE2 404-0B</b> 121.00	→ <b>3SE2 404-2B</b> 121.00			0.380
	<b>Overtravel plunger</b> (3SX3106)	→ <b>3SE2 404-1C</b> 138.00	→ <b>3SE2 404-0C</b> 138.00	→ <b>3SE2 404-2C</b> 138.00			0.400
	<b>Roller plunger</b> (3SX3107)	→ <b>3SE2 404-1D</b> 189.00	→ <b>3SE2 404-0D</b> 147.00	→ <b>3SE2 404-2D</b> 147.00			0.420
	<b>Roller lever</b> Actuator made of molded plastic (3SX3102)	→ <b>3SE2 404-1E</b> 136.00	→ <b>3SE2 404-0E</b> 136.00	→ <b>3SE2 404-2E</b> 136.00			0.381
	<b>Angular roller lever</b> Actuator made of molded plastic (3SX3104)	→ <b>3SE2 404-1F</b> 132.00	→ <b>3SE2 404-0F</b> 132.00	→ <b>3SE2 404-2F</b> 132.00			0.400
	<b>Roller crank</b> • finely adjustable from 10° to 10° (3SX3211+3SX3212)	→ <b>3SE2 404-1GW</b> 181.00	→ <b>3SE2 404-0GW</b> 141.00	→ <b>3SE2 404-2GW</b> 141.00			0.480
	• adjustable length, finely adjustable from 10° to 10° (3SX3211+3SX3213)	<b>3SE2 404-1UW</b> 161.00	<b>3SE2 404-0UW</b> 161.00	<b>3SE2 404-2UW</b> 161.00			0.479
	<b>Rod actuator</b> finely adjustable from 10° to 10° • Molded plastic rod (3SX3211+3SX3215)	<b>3SE2 404-1WW</b> 155.00	<b>3SE2 404-0WW</b> 155.00	<b>3SE2 404-2WW</b> 155.00			0.490
	• Aluminum rod (3SX3211+3SX3214)	<b>3SE2 404-1VW</b> 155.00	<b>3SE2 404-0VW</b> 155.00	<b>3SE2 404-2VW</b> 155.00			0.490
	<b>Fork lever</b> (3SX3127+3SX3115)	<b>3SE2 404-1T</b> 193.00	–	–			0.515

For operation, operating speed and travel, see Pages 13/100 to 13/105.

→ Positive opening acc. to IEC 60 947-5-1, Appendix K, and DIN VDE 0660 Part 200.

1) The actuator heads can be subsequently exchanged (see page 13/95).  
2) For conduit thread adaptors see page 13/97.

# 3SE International Limit Switches







## Position Switches

3SE2 100 to 3SE3 170 / 3SE2 303 / 3SE2 404  
Metal enclosure, 40 and 56 mm width

### Accessories

#### Actuator heads lamps

The actuator heads of the position switches can be subsequently exchanged for other variants.

	Actuators with mounting screws	For position switches	Order No.	List Price \$	Weight approx.
		3SE2 100-□□ 3SE2 120-□□ 3SE2 230-□□ 3SE2 303-□□ 3SE2 404-□□ 3SE3 170-□□		1 unit	kg
	<b>Plunger</b> includes screws and gasket	-.B	<b>3SX3 100</b>	<b>24.00</b>	0.018
	<b>Overtravel plunger</b> includes screws and gasket	-.C	<b>3SX3 106</b>	<b>43.00</b>	0.056
	<b>Roller plunger</b> includes screws and gasket • standard roller • stainless steel roller	-.D	<b>3SX3 107</b> <b>3SX3 263</b>	<b>51.00</b> <b>69.00</b>	0.082 0.080
	<b>Roller lever</b> includes screws and gasket • standard roller • stainless steel roller	-.E	<b>3SX3 102</b> <b>3SX3 275</b>	<b>28.00</b> <b>33.00</b>	0.034 0.050
	<b>Angular roller lever</b> includes screws and gasket • standard roller • stainless steel roller	-.F	<b>3SX3 104</b> <b>3SX3 276</b>	<b>35.00</b> <b>30.00</b>	0.043 0.050
3SX3 126 	<b>Wobble spring</b> <sup>1)</sup> (includes screws and gasket) • standard, spring 50 mm, plastic rod 50 mm • length 73 mm, spring 23.5 mm, stainless steel rod 10 mm • length 113 mm, spring 23.5 mm, stainless steel rod 50 mm • length 139.5 mm, spring 50 mm, plastic rod 50 mm with increased corrosion protection • length 139.5 mm, spring 50 mm, stainless steel rod 50 mm • length 239.5 mm, spring 150 mm, plastic rod 50 mm • length 239.5 mm, spring 150 mm, stainless steel rod 50 mm	-.R	<b>3SX3 126</b> <b>3SX3 282</b> <b>3SX3 285</b> <b>3SX3 284</b> <b>3SX3 281</b> <b>3SX3 283</b> <b>3SX3 311</b>	<b>59.00</b> <b>66.00</b> <b>66.00</b> <b>85.00</b> <b>77.00</b> <b>66.00</b> <b>82.00</b>	0.049 0.020 0.020 0.050 0.060 0.070 0.080





<sup>1)</sup> Not for safety circuits

# 3SE International Limit Switches

## Position Switches

3SE2 100 to 3SE3 170 / 3SE2 303 / 3SE2 404  
Metal enclosure, 40 and 56 mm width

### Accessories

Actuators with mounting screws		For position switches	Order No.	List Price \$	Weight approx.
		3SE2 100-□□ 3SE2 120-□□ 3SE2 303-□□ 3SE2 404-□□ 3SE3 170-□□		1 unit	kg
3SX3 211	 <p><b>Roller crank operating heads</b> (without lever, includes screws &amp; gasket)</p> <ul style="list-style-type: none"> <li>standard momentary (spring return), left and right operation</li> <li>momentary (spring return), left and/or right operation</li> <li>fork lever, maintained</li> </ul>	-GW, -U, -V, -W -GW, -U, -V, -W -1T	<b>3SX3 211</b> <b>3SX3 307</b> <b>3SX3 127</b>	<b>41.00</b> <b>48.00</b> <b>65.00</b>	0.112 0.085 0.131
3SX3 212	 <p><b>Roller crank levers</b> (operating head not included)</p> <ul style="list-style-type: none"> <li>standard, plastic roller, 19 mm dia.</li> <li>stainless steel roller, 19 mm dia.</li> <li>plastic roller, 30 mm dia.</li> <li>plastic roller, 50 mm dia.</li> <li>rubber roller, 50 mm dia.</li> </ul>	-.GW	<b>3SX3 212</b> <b>3SX3 265</b> <b>3SX3 278</b> <b>3SX3 301</b> <b>3SX3 280</b>	<b>9.00</b> <b>21.75</b> <b>17.00</b> <b>16.00</b> <b>18.00</b>	0.020 0.025 0.020 0.020 0.020
3SX3 213	 <p><b>Adjustable length roller crank</b> (operating head not included)</p> <ul style="list-style-type: none"> <li><b>levers with clamp</b> <ul style="list-style-type: none"> <li>standard, plastic roller, 19 mm dia.</li> <li>stainless steel roller, 19 mm dia.</li> <li>plastic roller, 30 mm dia.</li> <li>rubber roller, 50 mm dia.</li> </ul> </li> <li><b>levers without clamp</b> <ul style="list-style-type: none"> <li>rubber roller, 50 mm dia.</li> </ul> </li> </ul>	-.UW	<b>3SX3 213</b> <b>3SX3 268</b> <b>3SX3 302</b> <b>3SX3 304</b>	<b>24.00</b> <b>37.00</b> <b>30.00</b> <b>32.00</b>	0.024 0.030 0.025 0.020
3SX3 115	 <p><b>Fork lever</b> (operating head not included)</p> <ul style="list-style-type: none"> <li>standard, plastic rollers, 19 mm dia.</li> <li>stainless steel rollers, 19 mm dia.</li> </ul>	-1T	<b>3SX3 115</b> <b>3SX3 266</b>	<b>35.00</b> <b>61.00</b>	0.032 0.050
3SX3 215	 <p><b>Rod actuator</b> (operating head not included)</p> <ul style="list-style-type: none"> <li><b>with support</b> <ul style="list-style-type: none"> <li>standard, plastic rod</li> <li>aluminum rod</li> </ul> </li> <li><b>without support</b> <ul style="list-style-type: none"> <li>standard, plastic rod</li> <li>aluminum rod</li> </ul> </li> </ul>	-.WW -.VW -.WW -.VW	<b>3SX3 215</b> <b>3SX3 214</b> <b>3SX3 000</b> <b>3SX3 001</b>	<b>20.00</b> <b>20.00</b> <b>3.00</b> <b>3.00</b>	0.031 0.032 0.008 0.016

# 3SE International Limit Switches Position Switches

## Accessories

### Connectors

for fast installation and replacement of position and interlock switches

Design		Order No.	List Price \$	Weight approx.	
		Preferred type	1 unit	kg	
<b>Cable connectors for 3SE2 (with M20 x 1.5)</b>					
3SY3 131 	3SY3 123 	<b>Receptacle (6-poles + ground)</b> 250V max., 10A for M20 x 1.5 with 0.75 mm <sup>2</sup> connecting leads, for 3SX3 123 cable plug, molded plastic, IP 65 degree of protection	<b>3SY3 131</b>	<b>53.00</b>	0.030
		<b>Plug <sup>1)</sup></b> Molded plastic enclosure, degree of protection IP 65, screw terminals	<b>3SY3 123</b>	<b>57.40</b>	0.064
3SY3 131 	3SY3 123 	<b>Receptacle (4-pole), M 12 for M20 x 1.5</b> 250V max., 4A for 3RX1 505 coupling plug, with 0.75 mm <sup>2</sup> connecting lead, IP 67 degree of protection	<b>3SY3 127</b>	<b>36.00</b>	0.008
	3SY3 128 	<b>Receptacle (5-pole), M 12 for M20 x 1.5</b> 125V max., 4A for 3RX1584 with 0.25 mm <sup>2</sup> connecting lead, IP 67 degree of protection	<b>3SY3 128</b>	<b>36.00</b>	0.006
	3RX1 505 	<b>Plug (4-pole), M 12</b> with terminal compartment, can be pre- assembled	<b>3RX1 505</b>		0.016
3SX9918 	3RX1 584 	<b>Plug (5-pole), M 12</b> with terminal compartment, can be pre- assembled	<b>3RX1 584</b>		0.016
5VF1182 		<b>Plastic wire gland</b> PG 13.5 (6 mm long, with seal) PG 11 (6 mm long, with seal)	<b>5VF1 182</b> <b>5VF1 181</b>	<b>5.00</b> <b>5.00</b>	
<b>Adaptors for 3SE. (with M 16)</b>					
	3SX1997	metal M16 x 1.5 to 1/2" NPT	<b>3SX1997</b>	<b>8.40</b>	0.022
<b>Adaptors for 3SE2 (with M 20)</b>					
	3SX9918	plastic M20 x 1.5 wire gland	<b>3SB3901-0CK</b>	<b>5.00</b>	0.011
	3SX1998	metal M20 x 1.5 to 1/2" NPT	<b>3SX1998</b>	<b>8.60</b>	0.022
	3SX9918	plastic M20 x 1.5 to 1/2" NPT	<b>3SX9918</b>	<b>7.00</b>	0.012
<b>Adaptors for 3SE. (with M 25)</b>					
	3SX1999	metal M 25 x 1.5 to 1/2" NPT	<b>3SX1999</b>	<b>8.75</b>	0.022





1) For wiring, a crimping tool is necessary, max. conductor size 1 mm<sup>2</sup>.

# 3SE International Limit Switches

## Position Switches

3SE2 100 to 3SE3 170 / 3SE2 303 / 3SE2 404  
Metal enclosure, 40 and 56 mm width

### Accessories and spare parts

Design	Fig.	For position switches	Order No.	List Price \$ 1 unit	Weight approx. kg	Pack Units			
<b>Spare parts for 3SE. 1.0, 3SE. 230 and 3SE. 404</b>									
 	2	<b>Switch blocks with 2 contacts with moving double-break contacts</b>							
			• with snap-action contacts						
			- 1 NO + 1 NC	1	3SE. 1.0-1., 3SE2 230-1., 3SE2 404-1.	<b>3SE3 000-1A</b>	<b>27.00</b>	0.032	
			- 2 NC	1	3SE. 1.0-8., 3SE2 230-8., 3SE2 404-8.	<b>3SE3 000-8AV00</b>	<b>27.00</b>	0.020	
			• with slow-action contacts						
			- 1 NO + 1 NC	2	3SE. 1.0-0., 3SE. 230-0., 3SE. 404-0.	<b>3SE3 000-0A</b>	<b>27.00</b>	0.031	
- 2 NC		3SE. 1.0-6., 3SE. 230-6.	<b>3SE3 000-6A</b>	<b>27.00</b>	0.029				
- 2 NO		3SE. 1.0-7., 3SE. 230-7.	<b>3SE3 000-7A</b>	<b>27.00</b>	0.029				
• with slow-action make-before-break contacts									
- 1 NO + 1 NC	2	3SE. 1.0-3., 3SE. 230-3., 3SE. 404-2.	<b>3SE3 000-3A</b>	<b>27.00</b>	0.031				
<b>Spare parts for 3SE. 303</b>									
 	4	<b>Switch blocks with repeat plunger with 2 contacts - 1 NO + 1 NC</b>							
			for position switches with 4 contacts with moving double-break contacts						
			• with snap-action contacts		3	3SE. 404-1.	<b>3SE3 010-1A</b>	<b>37.00</b>	0.033
			• with slow-action contacts		4	3SE. 404-0.	<b>3SE3 010-0A</b>	<b>37.00</b>	0.032
			• with slow-action make-before-break contacts		4	3SE. 404-2.	<b>3SE3 010-3A</b>	<b>29.00</b>	0.034
			<b>Spare parts for 3SE. 303</b>						
	5	<b>Switch blocks with 3 contacts with moving double-break contacts</b>							
			• with slow-action contacts						
			- 1 NO + 2 NC	5	3SE. 303-0.	<b>3SE3 003-0A</b>	<b>53.00</b>	0.047	
			- 2 NO + 1 NC	5	3SE. 303-1.	<b>3SE3 003-1A</b>	<b>53.00</b>	0.047	
			• with slow-action make-before-break contacts						
			- 1 NO + 2 NC	5	3SE. 303-2.	<b>3SE3 003-2A</b>	<b>41.00</b>	0.047	
- 2 NO + 1 NC	5	3SE. 303-3.	<b>3SE3 003-3A</b>	<b>41.00</b>	0.063				

# 3SE International Limit Switches









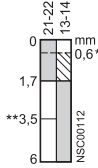
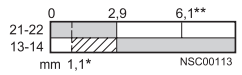

## Position Switches

**3SE3 020 / 3SE3 023**  
Open type

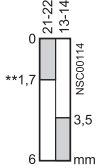
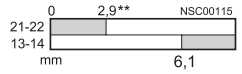
### Selection and ordering data

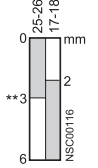
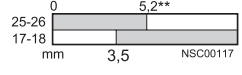
**2 contacts · Moving double break contacts · Degree of protection: Terminals IP 20, switching chamber IP 40**

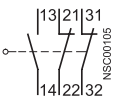
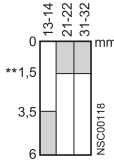
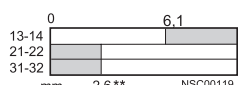
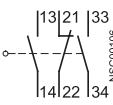
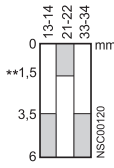
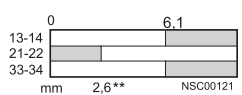
Tandem arrangement (2 × 2 contacts) is possible when 3SY3 121 adapter is used (see accessories below).

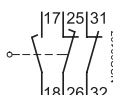
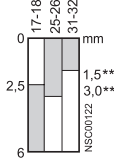
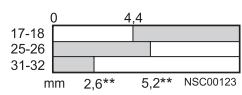
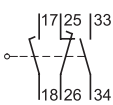
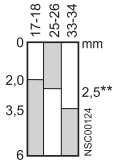
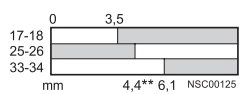
Internal circuit diagram Term. design. acc. to EN 50 013	Order No.	List Price \$	Weight approx.	Nominal travel and related terminals	Minimum force required along plunger axis
	Preferred type	1 unit	kg	0-line commencement of plunger travel ■ contact closed □ contact open * operating point on return ** positive opening acc. to IEC 60 947-5-1-3 along plunger axis perpend. to plunger axis $\alpha = 30^\circ$	
<b>Snap-action contacts, 6 mm stroke</b>					
3SE3 020-1A  	with 21 mm long plunger, 6mm Hub → <b>3SE3 020-1A</b>	<b>25.00</b>	0.036	 	6 N
<b>Slow-action contacts, 6 mm stroke</b>					
3SE3 020-0A  	with 21 mm long plunger, 6mm Hub → <b>3SE3 020-0A</b>	<b>25.00</b>	0.036	 	8 N
<b>Slow-action make-before-break contacts, 6 mm stroke</b>					
3SE 020-3A  	with 21 mm long plunger → <b>3SE3 020-3A</b>	<b>25.00</b>	0.036	 	8 N
3SY3 121 	Intermediate piece for tandem arrangement of 2-pole open-type position switches → <b>3SY3 121</b>	<b>2.00</b>	0.001		
<b>3 contacts · Moving double break contacts · Degree of protection: Terminals IP 20, switching chamber IP 40</b>					
<b>Slow-action contacts, 6 mm stroke</b>					
3SE3 023-0A  	with 21 mm plunger and repeat plunger, for tandem arrangement, 6mm Hub → <b>3SE3 023-0A</b>	<b>39.00</b>	0.051	 	11 N
	→ <b>3SE3 023-1A</b>	<b>39.00</b>	0.051	 	13 N
<b>Slow-action make-before-break contacts, 6 mm stroke</b>					
3SE3 023-2A  	with 21 mm plunger and repeat plunger, for tandem arrangement, 6mm Hub → <b>3SE3 023-2A</b>	<b>39.00</b>	0.051	 	11 N
	→ <b>3SE3 023-3A</b>	<b>39.00</b>	0.058	 	13 N

→ Safety function according to IEC 60 947-5-1, Appendix K.

For operation, operating speed and travel, see Page 13/112.

# 3SE International Limit Switches

## Position Switches

**3SE2 100 to 3SE3 170 / 3SE2 404**  
Metal enclosure, 40 and 56 mm width

### Operation, operating speed and travel or angle of actuators

#### 2 contacts · Standard and wide enclosure

Bars, cams, stops, etc. are used as actuating devices. The shape of the actuating device must provide the given angles for the leading and trailing edges.

For operation from the side, sparingly greased steel, POM (polyoxymethylene or polyacetal) or PA (polyamide) should be used as cam and bar material.

#### Operating speed along plunger axis

The actuating speed in the case of position switches with slow-action contacts is not permitted

to go lower than 15 mm/s for DC and 1 mm/s for AC. Position switches with snap-action contacts should be used when the speeds are lower.

#### 3SE2 404 position switches · 4 contacts · Wide enclosure

The data for operation, operating speed, travel and angle of operation is the same as for the

position switches with 2 switch blocks.

Two switch blocks with 2 contacts are used for position switches with 4 contacts.

Operation by a bar	Switch blocks	Nominal travel and related terminals	Switch blocks	Nominal travel and related terminals
operating pt acc. to EN 50 041 $v_{max}$ max. operating speed 0-line ref. line acc. to EN 50 041 H travel difference → direction of operation	Terminal designation acc. to EN 50 013	0-line reference line acc. to EN 50 041 S travel acc. to EN 50 041 ■ contact closed □ contact open * operating point on return ** positive opening acc. to IEC 60 947-5-1-3		

**Plunger** along plunger axis perpendicular to plunger axis along plunger axis

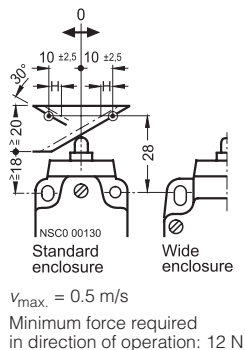
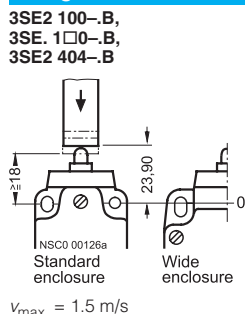

#### Slow-action contacts

##### 1 NC + 1 NO

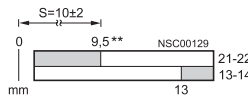
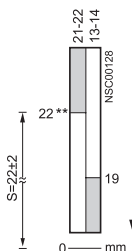
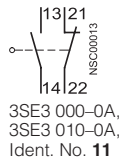

##### 2 NC

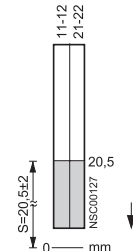
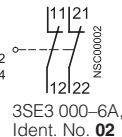

##### 1 NO + 1 NC with make-before-break

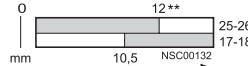
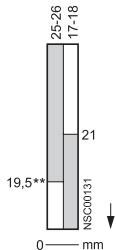
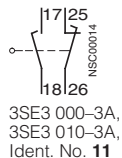

##### 2 NO

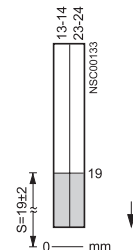
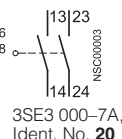

#### Snap-action contacts

##### 1 NC + 1 NO

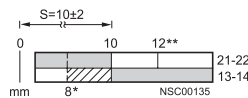
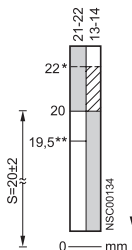
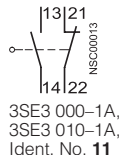

##### 2 NC

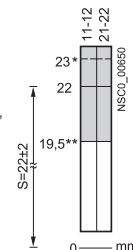
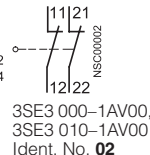



# 3SE International Limit Switches

## Position Switches

3SE2 100 to 3SE3 170 / 3SE2 230 / 3SE2 404  
Metal enclosure, 40 and 56 mm width

### Operation, operating speed and travel or angle of actuators

#### 2 or 4 contacts · Standard and wide enclosure

Operation by a bar	Switch blocks	Nominal travel and related terminals	Switch blocks	Nominal travel and related terminals
<ul style="list-style-type: none"> <li>⊙ operating pt. acc. to EN 50 041</li> <li><math>V_{max}</math> max. operating speed</li> <li>0-line ref. line acc. to EN 50 041</li> <li>H travel difference</li> <li>→ direction of operation</li> </ul>	Terminal designation acc. to EN 50 013	<ul style="list-style-type: none"> <li>0-line reference line acc. to EN 50 041</li> <li>S travel acc. to EN 50 041</li> <li>▬ contact closed</li> <li>□ contact open</li> <li>* operating point on return</li> <li>** positive opening acc. to IEC 60 947-5-1-3</li> </ul>		

#### Overtravel plunger, Type B

3SE2 100-C,  
3SE 1□0-C,  
3SE2 230-C,  
3SE2 404-C

www.DataSheet4U.com

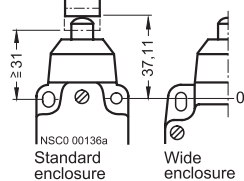

Wide enclosure

$V_{max} = 1.5 \text{ m/s}$

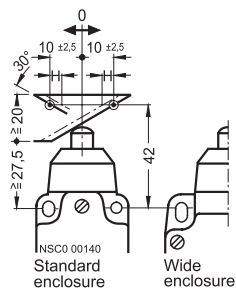

Wide enclosure

$V_{max} = 0.5 \text{ m/s}$

Minimum force required in direction of operation: 32 N

#### Slow-action contacts

##### 1 NC + 1 NO



3SE3 000-0A,  
3SE3 010-0A,  
Ident. No. **11**

along plunger axis

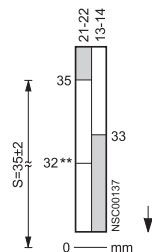

perpendicular to plunger axis

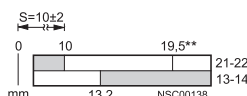

##### 2 NC



3SE3 000-6A,  
Ident. No. **02**

along plunger axis

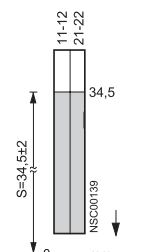

##### 1 NO + 1 NC With make-before-break



3SE3 000-3A,  
3SE3 010-3A,  
Ident. No. **11**

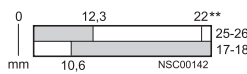
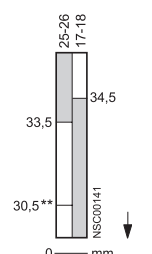

##### 2 NO



3SE3 000-7A,  
Ident. No. **20**

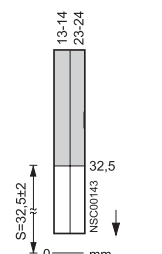

#### Snap-action contacts

##### 1 NC + 1 NO



3SE3 000-1A,  
3SE3 010-1A,  
Ident. No. **11**

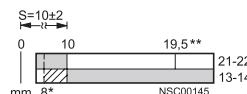
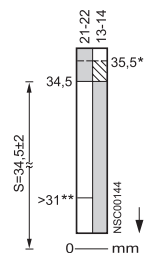

##### 2 NC



Ident. No. **02**

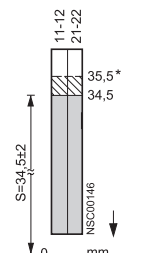

# 3SE International Limit Switches

## Position Switches

**3SE2 100 to 3SE3 170 / 3SE2 230 / 3SE2 404**  
**Metal enclosure, 40 and 56 mm width**

### Operation, operating speed and travel or angle of actuators

#### 2 or 4 contacts · Standard and wide enclosure

Operation by a bar	Switch blocks	Nominal travel and related terminals	Switch blocks	Nominal travel and related terminals
<ul style="list-style-type: none"> <li>⊙ operating pt acc. to EN 50 041</li> <li><math>v_{max}</math> max. operating speed</li> <li>0-line ref. line acc. to EN 50 041</li> <li>H travel difference</li> <li>→ direction of operation</li> </ul>	Terminal designation acc. to EN 50 013	<ul style="list-style-type: none"> <li>0-line reference line acc. to EN 50 041</li> <li>S travel acc. to EN 50 041</li> <li>■ contact closed</li> <li>□ contact open</li> <li>* operating point on return</li> <li>** positive opening acc. to IEC 60 947-5-1-3</li> </ul>		

#### Roller plunger, type C

**3SE2 100-D,**  
**3SE. 1□0-D,**  
**3SE2 230-D,**  
**3SE2 404-D**

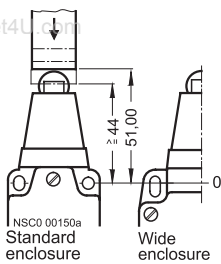

$v_{max.} = 1.5 \text{ m/s}$

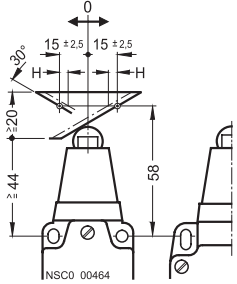

$v_{max.} = 1 \text{ m/s}$  (3SE3 230-D),  
 $v_{max.} = 0.5 \text{ m/s}$  (3SE3 1.0-D),  
 Minimum force required in direction of operation: 32 N

#### Slow-action contacts

##### 1 NC + 1 NO

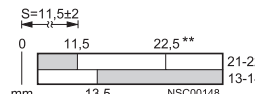
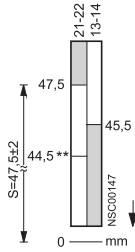
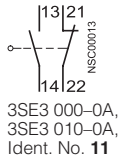

##### 2 NC

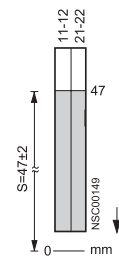
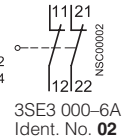

##### 1 NO + 1 NC With make-before-break

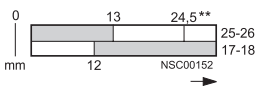
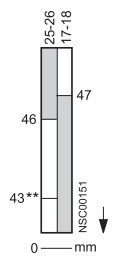
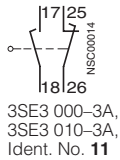

##### 2 NO

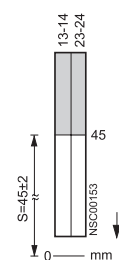
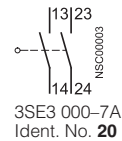

#### Snap-action contacts

##### 1 NC + 1 NO

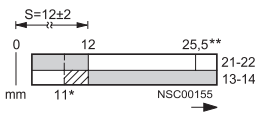
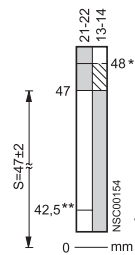
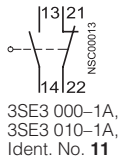

##### 2 NC

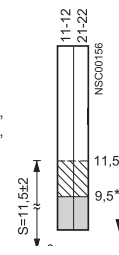
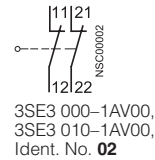

#### Fork lever

**3SE2 100-1T,**  
**3SE. 1□0-1T,**  
**3SE2 404-1T**

lateral actuation

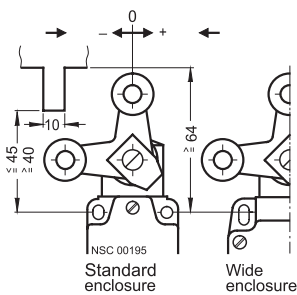

$v_{max.} = 2 \text{ m/s}$   
 Minimum force required in direction of operation: 30 N

#### Snap-action contacts

##### 1 NC + 1 NO

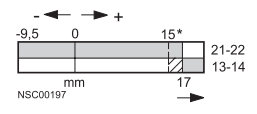
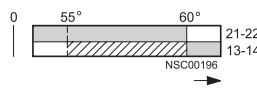
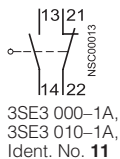

##### 2 NC

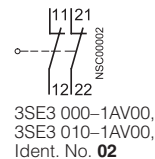

Deflection in direction of rotation

# 3SE International Limit Switches Position Switches

3SE2 100 to 3SE3 170 / 3SE2 230 / 3SE2 404  
Metal enclosure, 40 and 56 mm width

## Operation, operating speed and travel or angle of actuators

### 2 or 4 contacts · Standard and wide enclosure

Operation by a bar	Switch blocks	Nominal travel and related terminals	Switch blocks	Nominal travel and related terminals
<ul style="list-style-type: none"> <li>⊙ operating pt. acc. to EN 50 041</li> <li><math>\alpha, \gamma</math> approach angle</li> <li><math>v_{max}</math> max. operating speed</li> <li>0-line ref. line acc. to EN 50 041</li> <li>H travel difference</li> <li>→ direction of operation</li> </ul>	Terminal designation acc. to EN 50 013	<ul style="list-style-type: none"> <li>0-line reference line acc. to EN 50 041</li> <li>S travel acc. to EN 50 041</li> <li> contact closed</li> <li> contact open</li> <li>* operating point on return</li> <li>** positive opening to IEC 60 947-5-1-3</li> </ul>		

### Roller lever

3SE2 100-E, 3SE, 1□-E,  
3SE2 230-E, 3SE2 404-E

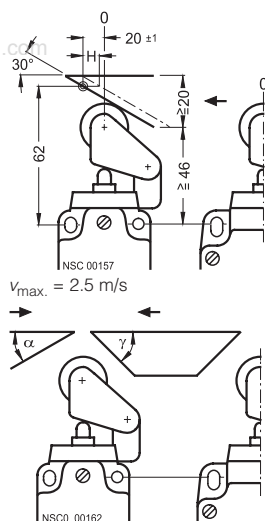

$v_{max} = 2.5 \text{ m/s}$   
Minimum force required in direction of operation: 12 N

### Slow-action contacts

1 NC + 1 NO

3SE3 000-0A,  
3SE3 010-0A,  
Ident. No. 11

1 NO + 1 NC

With make-bef.-break

3SE3 000-3A,  
3SE3 010-3A,  
Ident. No. 11

perpendicular to plunger axis

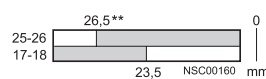
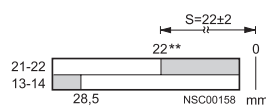

2 NC

3SE3 000-6A,  
Ident. No. 02

2 NO

3SE3 000-7A,  
Ident. No. 20

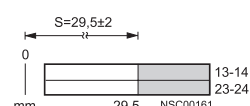
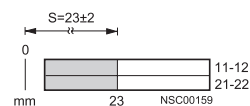

### Snap-action contacts

1 NC + 1 NO

3SE3 000-1A,  
3SE3 010-1A,  
Ident. No. 11

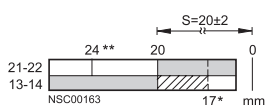

2 NC

Ident. No. 02

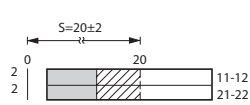

### Angular roller lever

3SE2 100-F, 3SE, 1□-F,  
3SE2 230-F, 3SE2 404-F

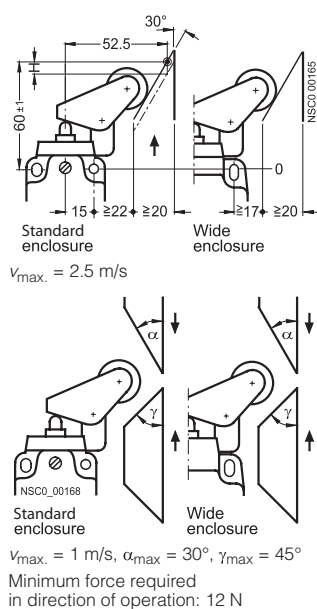

$v_{max} = 2.5 \text{ m/s}$   
Minimum force required in direction of operation: 12 N

### Slow-action contacts

1 NC + 1 NO

3SE3 000-0A,  
3SE3 010-0A,  
Ident. No. 11

1 NO + 1 NC

With make-before-break

3SE3 000-3A,  
3SE3 010-3A,  
Ident. No. 11

along plunger axis

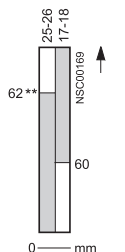
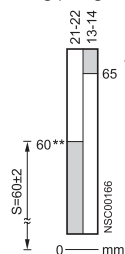

2 NC

3SE3 000-6A,  
Ident. No. 02

2 NO

3SE3 000-7A,  
Ident. No. 20

along plunger axis

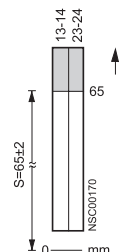
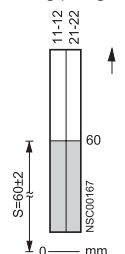

### Snap-action contacts

1 NC + 1 NO

3SE3 000-1A,  
3SE3 010-1A,  
Ident. No. 11

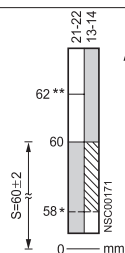

2 NC

Ident. No. 02

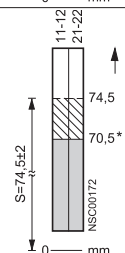

# 3SE International Limit Switches

## Position Switches

**3SE2 100 to 3SE3 170 / 3SE2 230 / 3SE2 404**  
Metal enclosure, 40 and 56 mm width

### Operation, operating speed and travel or angle of actuators

#### 2 or 4 contacts · Standard and wide enclosure

Operation by a bar	Switch blocks	Nominal travel and related terminals	Switch blocks	Nominal travel and related terminals
<ul style="list-style-type: none"> <li>⊙ operating pt acc. to EN 50 041</li> <li><math>\alpha</math> approach angle</li> <li><math>\beta</math> trailing angle</li> <li><math>v_{max}</math> max. operating speed</li> <li>0-line reference line acc. to EN 50 041</li> <li>S travel acc. to EN 50 041</li> <li>H travel difference</li> <li>→ direction of operation</li> </ul>	Terminal designation acc. to EN 50 013	<ul style="list-style-type: none"> <li>0-line ref. line acc. to EN 50 041</li> <li>S travel acc. to EN 50 041</li> <li>▬ contact closed</li> <li>□ contact open</li> <li>* operating point on return</li> <li>** positive opening to IEC 60 947-5-1-3</li> </ul>		

#### Roller crank, type A

repositionable and finely adjustable from 10° to 10°

**3SE2 100-GW, 3SE. 1□0-GW, 3SE2 230-GW, 3SE2 404-GW**

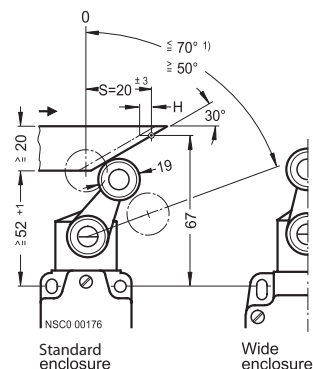

$v_{max} = 3 \text{ m/s}$

Minimum torque required in direction of operation: 25 Ncm

In special designs, contacts can only be operated from right or left. By twisting the plunger from the right and left.

perpendicular to plunger axis

#### Slow-action contacts

##### 1 NC + 1 NO

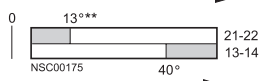
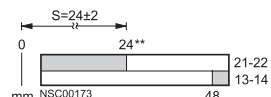
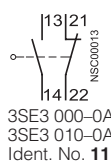

##### 1 NO + 1 NC

#### With make-bef.-break

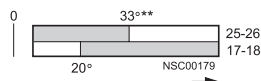
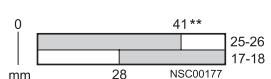
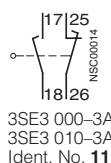

perpendicular to plunger axis

##### 2 NC

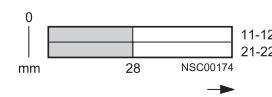
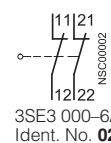

##### 2 NO

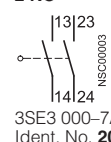

#### Snap-action contacts

##### 1 NC + 1 NO

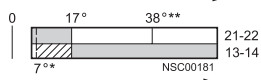
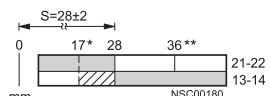
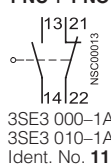

##### 2 NC

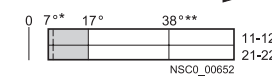
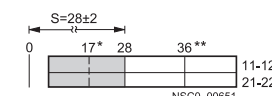
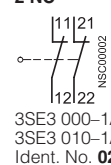

#### Roller crank, adjustable length

finely adjustable from 10° to 10°

**3SE2 100-UW, 3SE. 1□0-UW, 3SE2 230-U, 3SE2 404-UW**

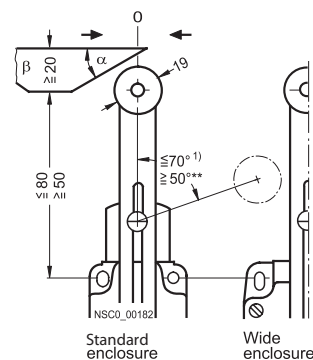

$v_{max} = 1 \text{ m/s}$ ,  $\alpha_{max} = 30^\circ$ ,  $\beta_{max} = 30^\circ$

Minimum torque required in direction of operation: 25 Ncm

Contact operation either from right or left or from right and left.

Deflection in direction of rotation

#### Slow-action contacts

##### 1 NC + 1 NO

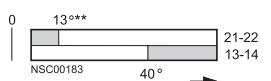
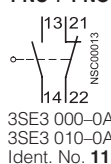

##### 1 NO + 1 NC

#### With make-bef.-break

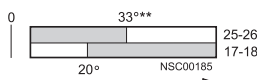
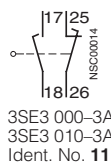

##### 2 NC

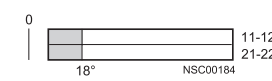
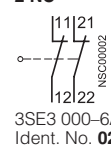

##### 2 NO

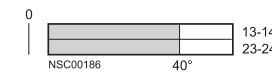
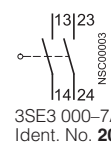

#### Snap-action contacts

##### 1 NC + 1 NO

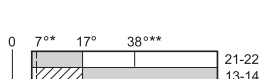
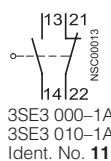

##### 2 NC

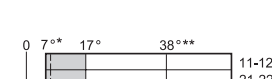
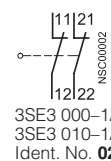

1) Max. operating angle 70°.

# 3SE International Limit Switches Position Switches

3SE2 100 to 3SE3 170 / 3SE2 230 / 3SE2 404  
Metal enclosure, 40 and 56 mm width

## Operation, operating speed and travel or angle of actuators

### 2 or 4 contacts · Standard and wide enclosure

Operation by a bar	Switch blocks	Nominal travel and related terminals	Switch blocks	Nominal travel and related terminals
<p>⊙ operating pt acc. to EN 50 041</p> <p><math>V_{max}</math> max. operating speed</p> <p>0-line ref. line acc. to EN 50 041</p> <p>→ direction of operation</p>	Terminal designation acc. to EN 50 013	<p>0-line ref. line acc. to EN 50 041</p> <p>■ contact closed</p> <p>□ contact open</p> <p>* operating point on return</p> <p>** positive opening to IEC 60 947-5-1-3</p>		

### Rod actuator

finely adjustable from 10° to 10°

3SE2 100-WW, 3SE. 1□0-WW,  
3SE2 230-W, 3SE2 404-WW

3SE2 100-VW, 3SE. 1□0-VW,  
3SE2 230-V, 3SE2 404-VW

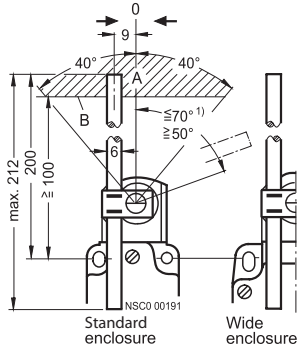

A = Operating range  
B = Lower edge of actuator

$V_{max}$  = 3 m/s

Minimum torque required  
in direction of operation: 25 Nm

In special designs, contacts can only be operated from right or left. By twisting the plunger from the right and left.

### Slow-action contacts

#### 1 NC + 1 NO

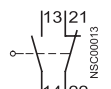

3SE3 000-0A,  
3SE3 010-0A,  
Ident. No. 11

#### 1 NO + 1 NC With make-before-break

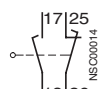

3SE3 000-3A,  
3SE3 010-3A,  
Ident. No. 11

in direction of rotation

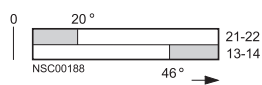

#### 2 NC

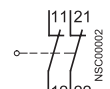

3SE3 000-6A,  
Ident. No. 02

#### 2 NO

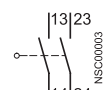

3SE3 000-7A,  
Ident. No. 20

in direction of rotation

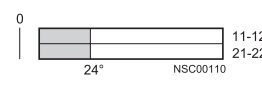

### Snap-action contacts

#### 1 NC + 1 NO

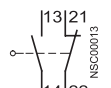

3SE3 000-1A,  
3SE3 010-1A,  
Ident. No. 11

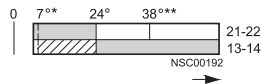

#### 2 NC

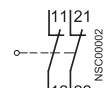

3SE3 000-1AV00,  
3SE3 010-1AV00,  
Ident. No. 02

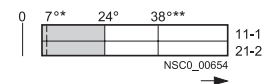

### Spring rod

3SE2 100-1R, 3SE. 1□0-1R,  
3SE2 230-R

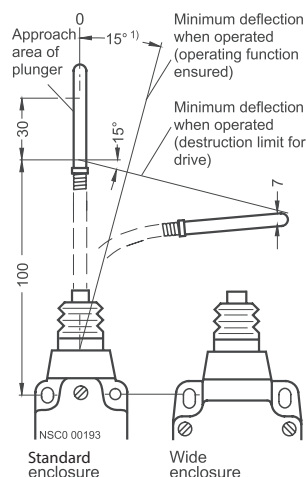

$V_{max}$  = 1 m/s, approachable from all sides

Minimum force required  
in direction of operation: 12 N  
with lateral deflection at the tip: 2.5 N

1) Max. operating angle 70°.

Deflection of spring rod

### Snap-action contacts

#### 1 NC + 1 NO

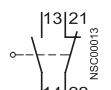

3SE3 000-1A,  
3SE3 010-1A,  
Ident. No. 11

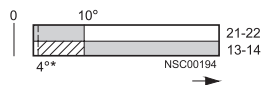

#### 2 NC

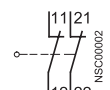

3SE3 000-1AV00,  
3SE3 010-1AV00,  
Ident. No. 02

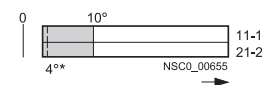

# 3SE International Limit Switches

## Position Switches

**3SE2 303**  
Metal enclosure, 56 mm width

### Operation, operating speed and travel or angle of actuators

3 contacts · Wide enclosure

Operation by a bar	Switch blocks	Nominal travel and related terminals	Minimum force required in direction of operation
<ul style="list-style-type: none"> <li>⊙ operating pt acc. to EN 50 041</li> <li><math>v_{max}</math> max. operating speed</li> <li>O-line reference line acc. to EN 50 041</li> <li>H travel difference</li> <li>→ direction of operation</li> </ul>	Terminal designation acc. to EN 50 013	<ul style="list-style-type: none"> <li>O-line reference line acc. to EN 50 041</li> <li>S travel acc. to EN 50 041</li> <li>■ contact closed</li> <li>□ contact open</li> <li>* operating point on return</li> <li>** positive opening to IEC 60 947-5-1-3</li> </ul>	Minimum force required in direction of operation

#### Plunger

**3SE2 303-B**

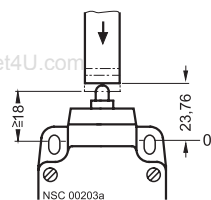

$v_{max.} = 1.5 \text{ m/s}$

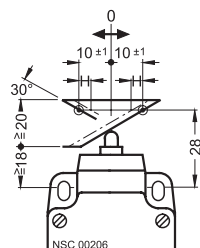

$v_{max.} = 0.5 \text{ m/s}$

#### Slow-action contacts

**1 NO + 2 NC**

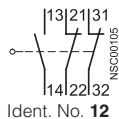

along plunger axis

perpendicular to plunger axis

16 N

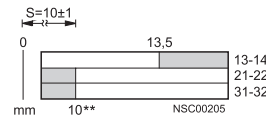
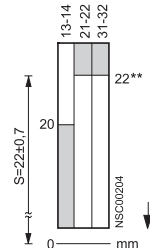

**2 NO + 1 NC**

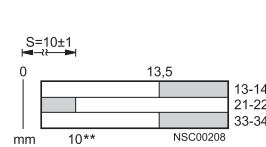
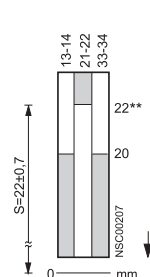
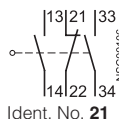

18 N

**1 NO + 2 NC**  
make-before-break

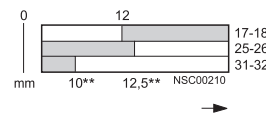
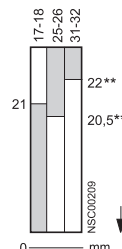
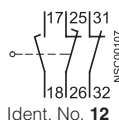

16 N

**2 NO + 1 NC**  
make-before-break

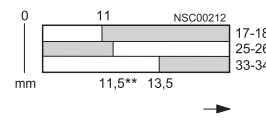
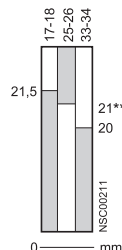
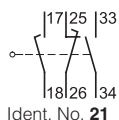

18 N

# 3SE International Limit Switches

## Position Switches

**3SE2 303**  
Metal enclosure, 56 mm width

1  
2  
3  
4  
5  
6  
7  
8  
9  
10  
11  
12  
13

### Operation, operating speed and travel or angle of actuators

#### 3 contacts · Wide enclosure

Operation by a bar	Switch blocks	Nominal travel and related terminals	Minimum force required in direction of operation
<ul style="list-style-type: none"> <li>⊙ operating pt. acc. to EN 50 041</li> <li><math>V_{max}</math> max. operating speed</li> <li>0-line reference line acc. to EN 50 041</li> <li>H travel difference</li> <li>→ direction of operation</li> </ul>	Terminal designation acc. to EN 50 013	<ul style="list-style-type: none"> <li>0-line reference line acc. to EN 50 041</li> <li>S travel acc. to EN 50 041</li> <li>■ contact closed</li> <li>□ contact open</li> <li>* operating point on return</li> <li>** positive opening to IEC 60 947-5-1-3</li> </ul>	Minimum force required in direction of operation

#### Overtravel plunger

##### 3SE2 303-C

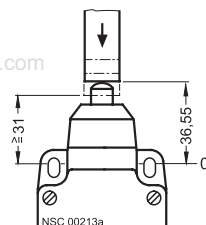

$V_{max.} = 1.5 \text{ m/s}$

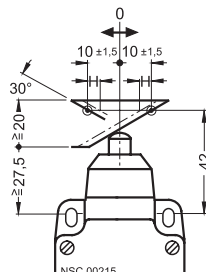

$V_{max.} = 0.5 \text{ m/s}$

#### Slow-action contacts

##### 1 NO + 2 NC

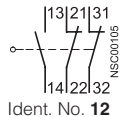

along plunger axis

perpendicular to plunger axis

35 N

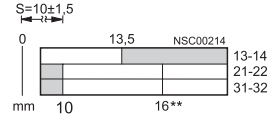
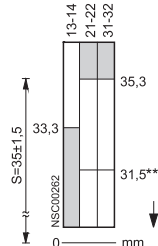

##### 2 NO + 1 NC

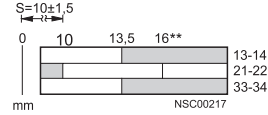
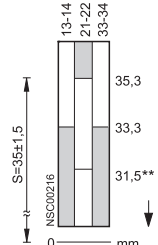
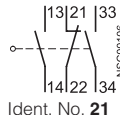

37 N

##### 1 NO + 2 NC make-before-break

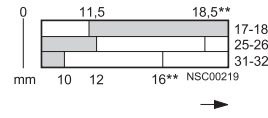
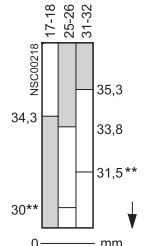
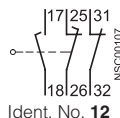

35 N

##### 2 NO + 1 NC make-before-break

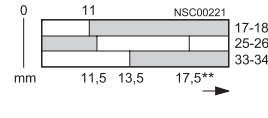
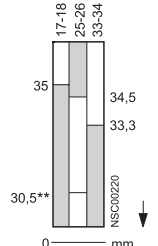
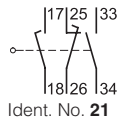

37 N

# 3SE International Limit Switches

## Position Switches

**3SE2 303**  
Metal enclosure, 56 mm width

### Operation, operating speed and travel or angle of actuators

#### 3 contacts · Wide enclosure

Operation by a bar	Switch blocks	Nominal travel and related terminals	Minimum force required in direction of operation
<ul style="list-style-type: none"> <li>⊙ operating pt. acc. to EN 50 041</li> <li><math>v_{max}</math> max. operating speed</li> <li>0-line reference line acc. to EN 50 041</li> <li>H travel difference</li> <li>→ direction of operation</li> </ul>	Terminal designation acc. to EN 50 013	<ul style="list-style-type: none"> <li>0-line reference line acc. to EN 50 041</li> <li>S travel acc. to EN 50 041</li> <li>■ contact closed</li> <li>□ contact open</li> <li>* operating point on return</li> <li>** positive opening to IEC 60 947-5-1-3</li> </ul>	Minimum force required in direction of operation

#### Roller plunger

**3SE2 303-D**

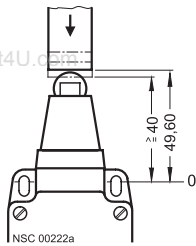

NSC 00222a

$v_{max.} = 1.5 \text{ m/s}$

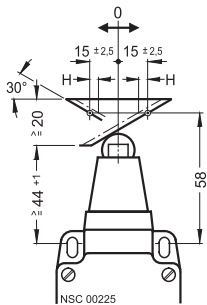

NSC 00225

$v_{max.} = 1 \text{ m/s}$

#### Slow-action contacts

**1 NO + 2 NC**

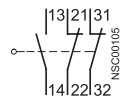

Ident. No. **12**

along plunger axis

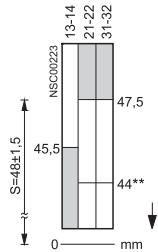

perpendicular to plunger axis

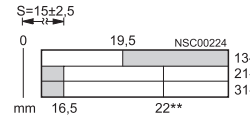

35 N

**2 NO + 1 NC**

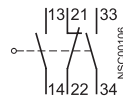

Ident. No. **21**

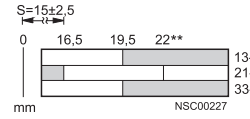
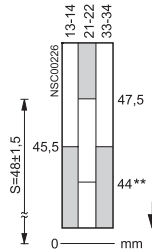

37 N

**1 NO + 2 NC**  
**make-before-break**

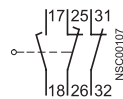

Ident. No. **12**

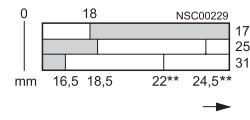
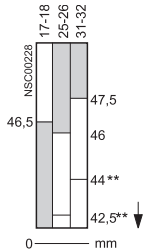

35 N

**2 NO + 1 NC**  
**make-before-break**

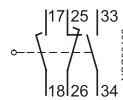

Ident. No. **21**

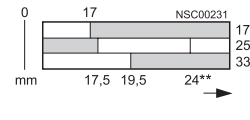
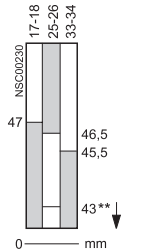

37 N



### Operation, operating speed and travel or angle of actuators

#### 3 contacts · Wide enclosure

Operation by a bar	Switch blocks	Nominal travel and related terminals	Minimum force required in direction of operation
○ operating pt acc. to EN 50 041 $\alpha$ approach angle $\beta$ trailing angle $\gamma$ approach angle $v_{max}$ max. operating speed 0-line reference line acc. to EN 50 041 H travel difference → direction of operation	Terminal designation acc. to EN 50 013	0-line reference line acc. to EN 50 041 S travel acc. to EN 50 041 ■ contact closed □ contact open ** positive opening to IEC 60 947-5-1-3	

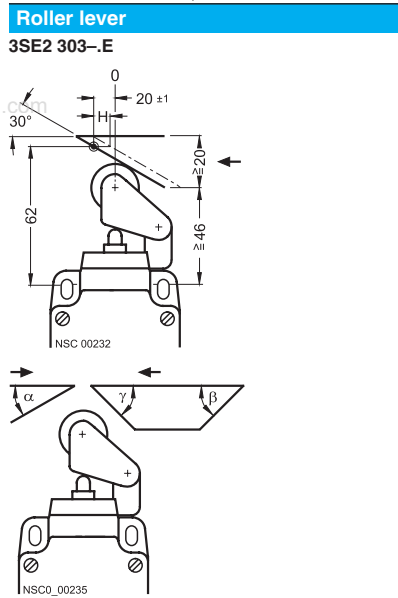

For operation perpendicular to plunger axis:  
 $v_{max} = 1 \text{ m/s}$  at  $\alpha_{max} = 30^\circ$   
 $v_{max} = 2.5 \text{ m/s}$  at  $\gamma_{max} = 45^\circ$   
 $\beta_{max} = 45^\circ$   
 For operation along plunger axis:  $v_{max} = 1.5 \text{ m/s}$

Switch blocks	Nominal travel and related terminals	Minimum force required in direction of operation
<b>1 NO + 2 NC</b>  Ident. No. <b>12</b>	perpendicular to plunger axis  15 N	
<b>2 NO + 1 NC</b>  Ident. No. <b>21</b>	 17 N	
<b>1 NO + 2 NC make-before-break</b>  Ident. No. <b>12</b>	 15 N	
<b>2 NO + 1 NC make-before-break</b>  Ident. No. <b>21</b>	 17 N	

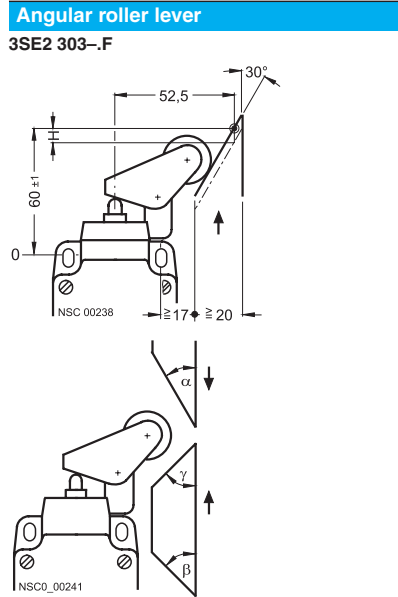

For operation along plunger axis:  
 $v_{max} = 1 \text{ m/s}$  at  $\alpha_{max} = 30^\circ$   
 $v_{max} = 2.5 \text{ m/s}$  at  $\gamma_{max} = 45^\circ$   
 $v_{max} = 2.5 \text{ m/s}$  at  $\beta_{max} = 45^\circ$

Switch blocks	Nominal travel and related terminals	Minimum force required in direction of operation
<b>1 NO + 2 NC</b>  Ident. No. <b>12</b>	along plunger axis  15 N	
<b>2 NO + 1 NC</b>  Ident. No. <b>21</b>	 17 N	
<b>1 NO + 2 NC make-before-break</b>  Ident. No. <b>12</b>	 15 N	
<b>2 NO + 1 NC make-before-break</b>  Ident. No. <b>21</b>	 17 N	

# 3SE International Limit Switches

## Position Switches

**3SE2 303**  
Metal enclosure, 56 mm width

### Operation, operating speed and travel or angle of actuators

#### 3 contacts · Wide enclosure

Operation by a bar	Switch blocks	Nominal travel and related terminals	Minimum force required in direction of rotation
<ul style="list-style-type: none"> <li>⊙ operating pt acc. to EN 50 041</li> <li><math>v_{max}</math> max. operating speed</li> <li>0-line reference line acc. to EN 50 041</li> <li>H travel difference</li> <li>→ direction of operation</li> </ul>	Terminal designation acc. to EN 50 013	<ul style="list-style-type: none"> <li>0-line reference line acc. to EN 50 041</li> <li>S travel acc. to EN 50 041</li> <li>■ contact closed</li> <li>□ contact open</li> <li>** positive opening to IEC 60 947-5-1-3</li> </ul>	Minimum force required in direction of rotation

#### Roller crank

finely adjustable from 10° to 10°

**3SE2 303-.GW-Z**  
**A31**

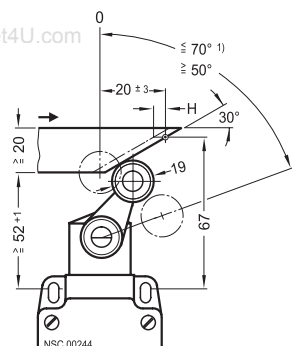

$v_{max.} = 3 \text{ m/s}$

In special designs contacts can only be operated from right or left. By twisting the plunger from the right and left.

#### Slow-action contacts

##### 1 NO + 2 NC

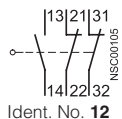

Ident. No. **12**

##### 2 NO + 1 NC

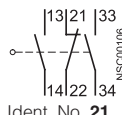

Ident. No. **21**

##### 1 NO + 2 NC make-before-break

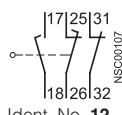

Ident. No. **12**

##### 2 NO + 1 NC make-before-break

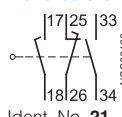

Ident. No. **21**

perpendicular to plunger axis

25 Ncm

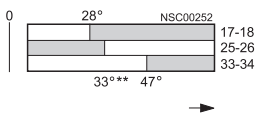
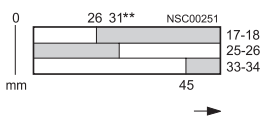
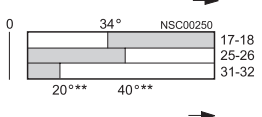
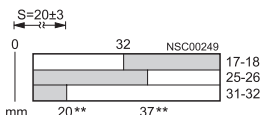
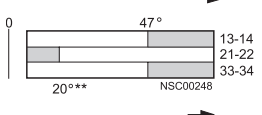
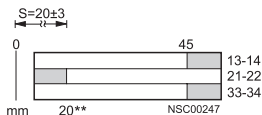
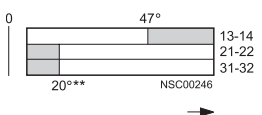
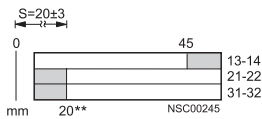

1) Max. operating angle 70°.  
Max. deflection for adjustment purposes 90°.

# 3SE International Limit Switches

## Position Switches

**3SE2 303**  
Metal enclosure, 56 mm width

1  
2  
3  
4  
5  
6  
7  
8  
9  
10  
11  
12  
13

### Operation, operating speed and travel or angle of actuators

#### 3 contacts - Wide enclosure

Operation by a bar	Switch blocks	Nominal travel and related terminals	Minimum force required in direction of rotation
○ operating pt acc. to EN 50 041 $\alpha$ approach angle $\beta$ trailing angle $v_{max}$ max. operating speed 0-line reference line acc. to EN 50 041 → direction of operation	Terminal designation acc. to EN 50 013	0-line reference line acc. to EN 50 041 S travel acc. to EN 50 041  ** positive opening to IEC 60 947-5-1-3	Minimum force required in direction of rotation

#### Roller crank, adjustable length

finely adjustable from 10° to 10°

#### 3SE2 303-UW

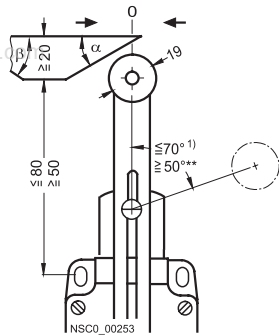

$v_{max} = 3 \text{ m/s}$ ,  
 $\alpha_{max} = 30^\circ$ ,  
 $\beta_{max} = 30^\circ$

In special designs contacts can only be operated from right or left. By twisting the plunger from the right and left.

#### Slow-action contacts

perpendicular to plunger axis

25 Ncm

#### 1 NO + 2 NC

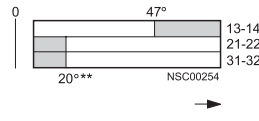
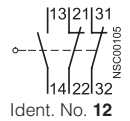

#### 2 NO + 1 NC

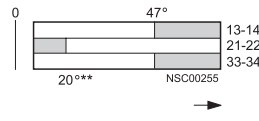
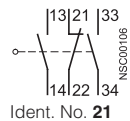

#### 1 NO + 2 NC make-before-break

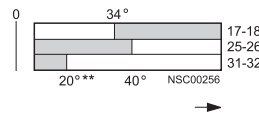
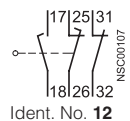

#### 2 NO + 1 NC make-before-break

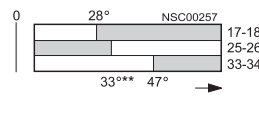
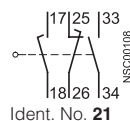

1) Max. operating angle 70°.



# 3SE International Limit Switches

## Position Switches

3SE2 100 to 3SE3 170  
Metal enclosure, 40 and 56 mm width

### Dimension drawings

#### 3SE2 1.0, 3SE3 1.0

**3SE. 1□0**  
narrow enclosure, 2 contacts,  
with plunger

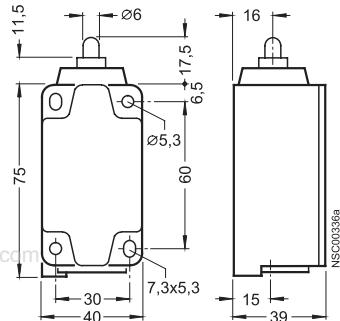

**3SE2 100**  
wide enclosure, 2 contacts,  
with plunger

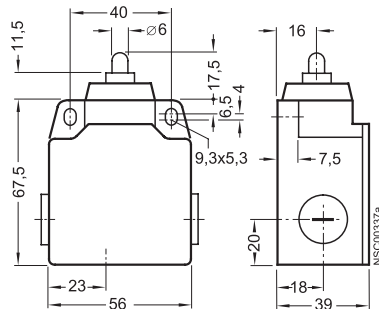

#### Actuators for 3SE2 1.0, 3SE3 1.0 position switches

##### Overtravel plunger, Form B

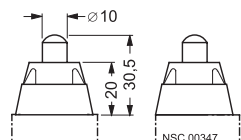

##### Roller plunger, Form C

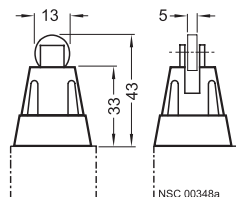

##### Roller lever

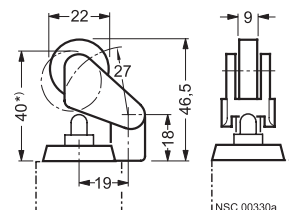

\* Lever in final position

##### Angular roller lever

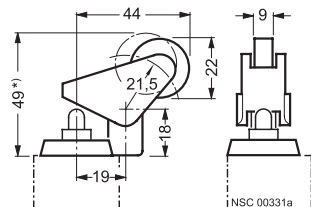

\* Lever in final position

##### 3SX3 212 roller crank for 3SX3 211 actuator heads

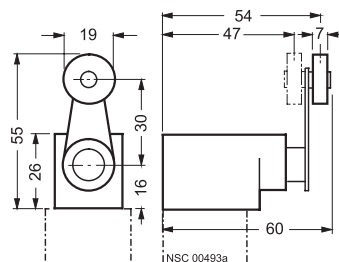

##### Fork lever

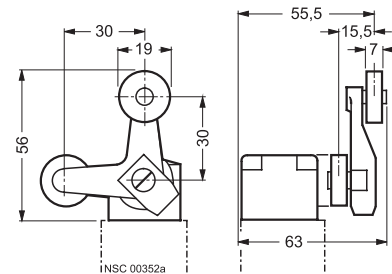

##### Roller crank, adjustable length

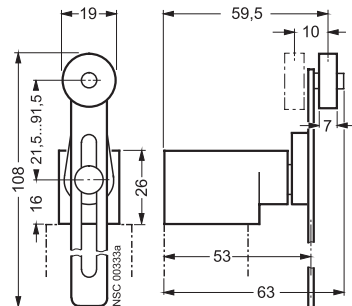

##### Rod actuator, adjustable length, Form D

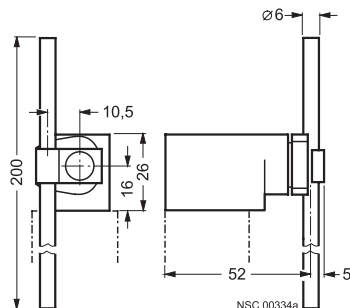

##### Wobble spring

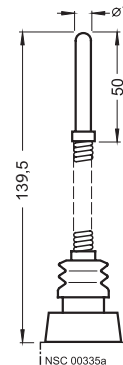

# 3SE International Limit Switches

## Position Switches

**3SE2 303 / 3SE2 404**  
**Metal enclosure, 56 mm width**

### Dimension drawings

**3SE2 303**  
 wide enclosure, 3 contacts

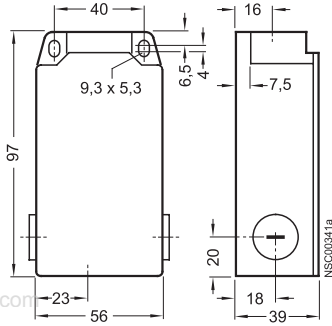

**3SE2 404**  
 wide enclosure, 4 contacts

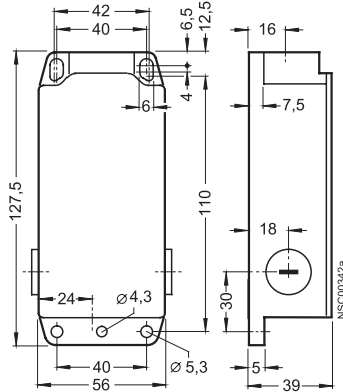

### Open-type

**3SE3 020-A**

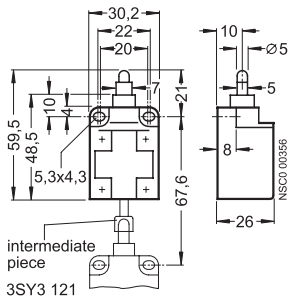

**3SE3 023-A**

