

# High Dynamic Range LNA, 1800 - 2200 MHz

AM50-0012

## Features

- Ideal for Base Station Applications
- High Gain: 19 dB @ 2000 MHz
- Low Noise Figure: 1.4 dB
- High Input IP3: +13 dBm
- Small Footprint 3mm FQFP-N Package

## Description

M/A-COM's AM50-0012 is a high dynamic range, GaAs MMIC, low noise amplifier in a low-cost small footprint 3mm FQFP-N package. It employs external matching to obtain optimum noise figure and intercept performance. The AM50-0012 is operated with a supply voltage of +5V.

The AM50-0012 is ideally suited for use where low noise figure, high gain, and high dynamic range are required. Typical applications included receiver front ends in TDMA, CDMA, and DCS base stations. It may also be used as an IF amplifier in certain other communication systems.

The AM50-0012 is fabricated using a low-cost 0.5-micron gate E-D SAGFET GaAs process. This process features full passivation for increased reliability. The AM50-0012 is 100% RF tested to ensure performance specification compliance.

## 3mm, 12-Lead, FQFP-N

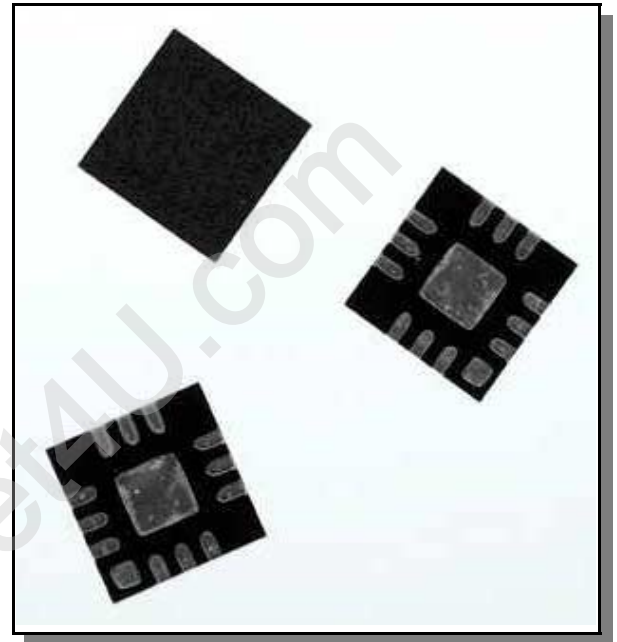

## Electrical Specifications: $T_A = 25^\circ\text{C}$ , $Z_0 = 50 \text{ Ohm}$ , $F = 2000 \text{ MHz}$ , $P_{IN} = -30 \text{ dBm}$

Parameter	Test Conditions	Units	Min	Typ	Max
Gain	5V	dB	18	19	21
Noise Figure	5V	dB	—	1.4	1.7
Output P1dB	5V	dBm	—	20	—
Input IP3	5V	dBm	11	13	—
Output IP3	5V	dBm	—	32	—
Input Return Loss	5V	dB	—	12	—
Output Return Loss	5V	dB	—	12	—
Drain Current	5V	mA	—	80	100

## Functional Block Diagram

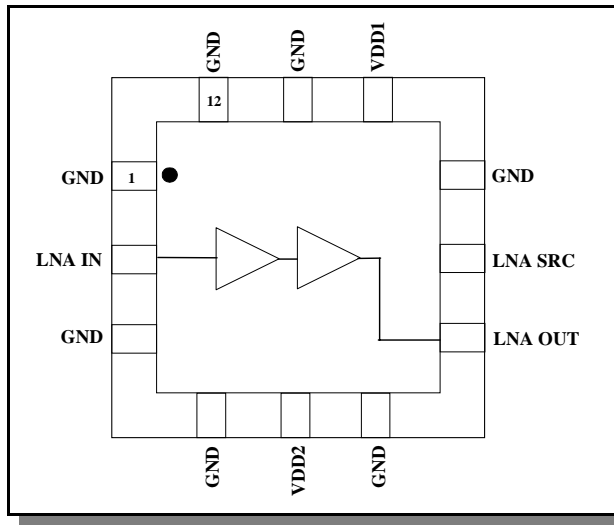

## Sample Board Schematic

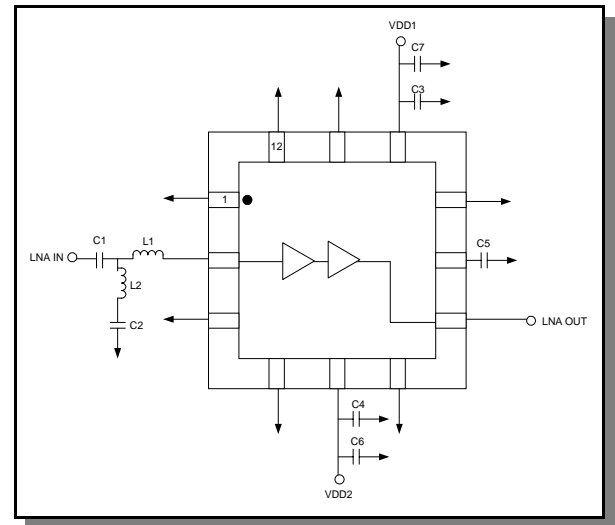

## Pin Configuration <sup>1</sup>

Pin No.	Function	Pin No.	Function
1	GND	7	LNA OUT
2	LNA IN	8	LNA SRC
3	GND	9	GND
4	GND	10	VDD1
5	VDD2	11	GND
6	GND	12	GND

1. The exposed pad centered on the package bottom must be connected to RF and DC Ground.

## External Circuitry Parts List

Ref. Designation	Value	Purpose
C1	3.3 pF	LNA Matching/DC Block
C2	0.1 μF	DC Block
C3, C4	1000 pF	RF Bypass
C5, C6, C7	0.1 μF	RF Bypass
L1	2 nH	LNA Matching
L2	2 nH	LNA Matching

## Absolute Maximum Ratings <sup>2</sup>

Parameter	Absolute Maximum
Supply Voltage	7V
RF Input Power	15 dBm
Operating Temperature	-40°C to +85°C
Storage Temperature	-65°C to +150°C

2. Exceeding any one or combination of these limits may cause permanent damage to this device.

M/A-COM Inc. and its affiliates reserve the right to make changes to the product(s) or information contained herein without notice.

Visit [www.macom.com](http://www.macom.com) for additional data sheets and product information.

Typical Performance Curves

Gain vs. Temperature

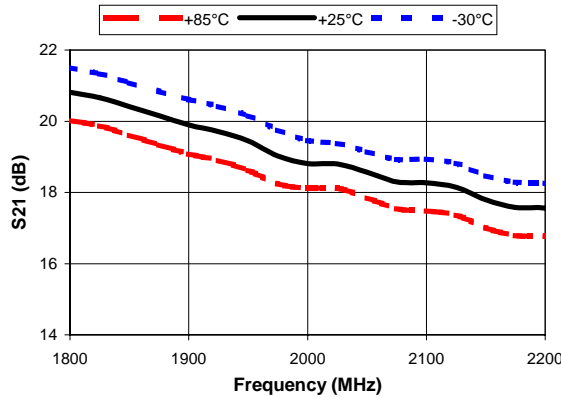

Input Return Loss vs. Temperature

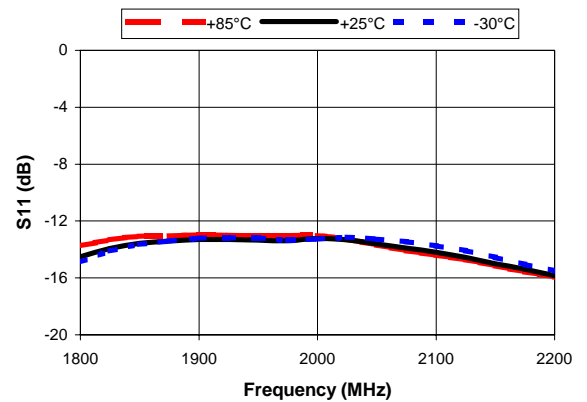

Output Return Loss vs. Temperature

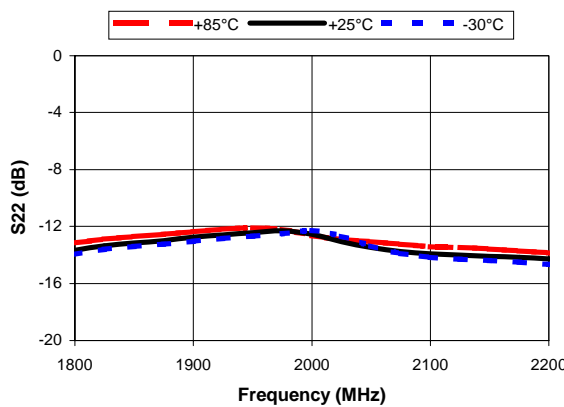

Noise Figure vs. Temperature

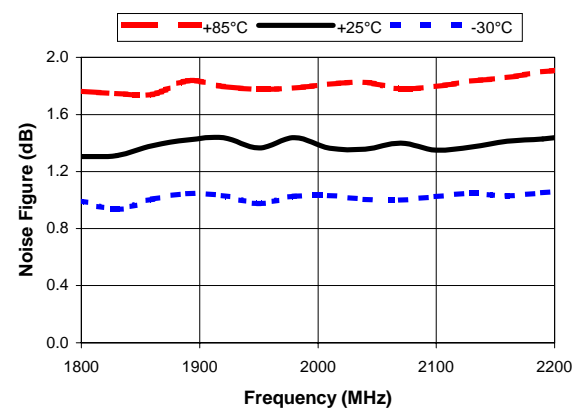

Input IP3 vs. Temperature  
(Pin = -15 dBm)

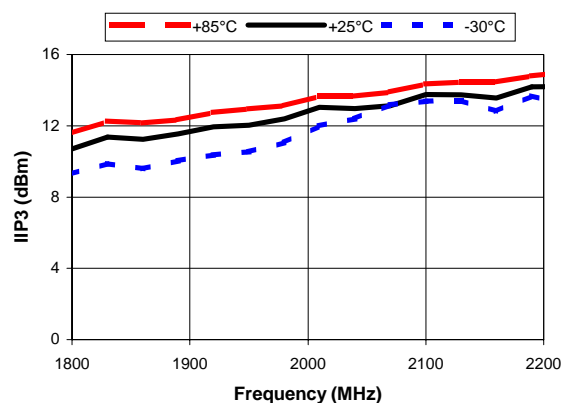

M/A-COM Inc. and its affiliates reserve the right to make changes to the product(s) or information contained herein without notice.

Visit [www.macom.com](http://www.macom.com) for additional data sheets and product information.

- North America: Tel. (800) 366-2266
- Asia/Pacific: Tel.+81-44-844-8296, Fax +81-44-844-8298
- Europe: Tel. +44 (1344) 869 595, Fax+44 (1344) 300 020

3mm, 12-Lead, FQFP-N

Recommended PCB Configuration

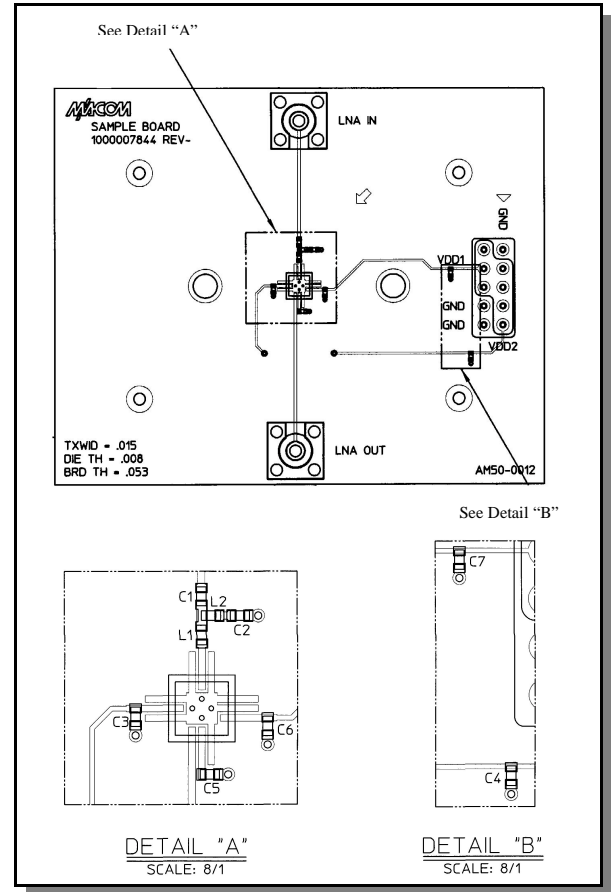
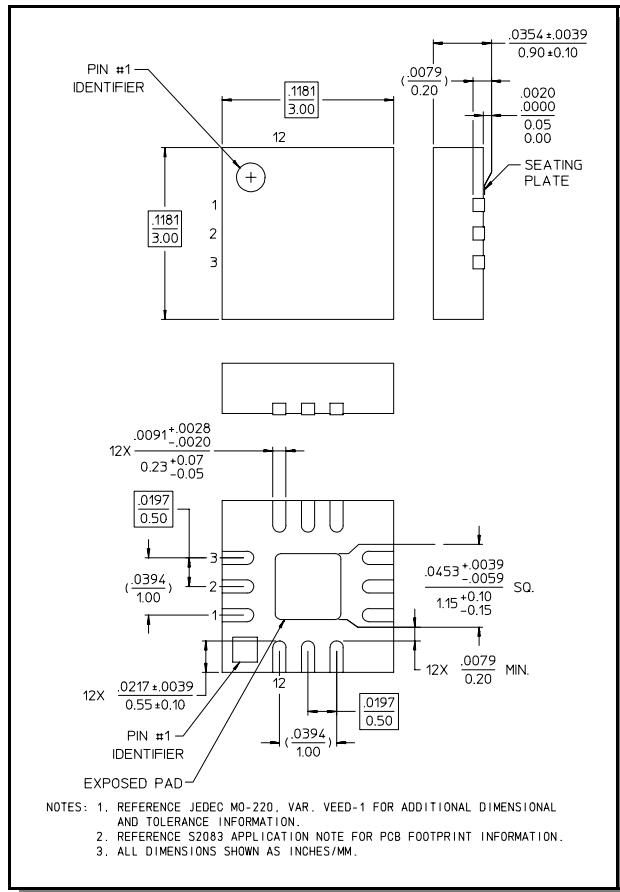

Ordering Information <sup>3</sup>

Part Number	Package
AM50-0012	Bulk Packaging
AM50-0012TR	Tape and Reel (1K Reel)
AM50-0012TR-3000	Tape and Reel (3K Reel)
AM50-0012SMB	Units Mounted on Test Board

3. Reference Application Note M513 for reel size information.

M/A-COM Inc. and its affiliates reserve the right to make changes to the product(s) or information contained herein without notice.

Visit [www.macom.com](http://www.macom.com) for additional data sheets and product information.