

8Mb Ultra-Low Power Asynchronous CMOS SRAM

512Kx16 bit

Overview

The N08T1630Cx8 is an integrated memory device containing a low power 8 Mbit SRAM built using a self-refresh DRAM array organized as 512,288 words by 16 bits. It is designed to be identical in operation and interface to standard 6T SRAMs. The device is designed for low standby and operating current and includes a power-down feature to automatically enter standby mode. The device operates with two chip enable ($\overline{CE1}$ and $\overline{CE2}$) controls and output enable (\overline{OE}) to allow for easy memory expansion. Byte controls (\overline{UB} and \overline{LB}) allow the upper and lower bytes to be accessed independently and can also be used to deselect the device. The N08T1630Cx8 is optimal for various applications where low-power is critical such as battery backup and hand-held devices. The device can operate over a very wide temperature range of -40°C to $+85^{\circ}\text{C}$ and is available in JEDEC standard BGA and TSOP2 packages compatible with other standard 512Kb x 16 SRAMs.

Features

- **Single Wide Power Supply Range**
2.7 to 3.6 Volts
- **Very low standby current**
70 μA at 3.0V (Max)
- **Very low operating current**
2.0mA at 3.0V and 1 μs (Typical)
- **Simple memory control**
Dual Chip Enables ($\overline{CE1}$ and $\overline{CE2}$)
Byte control for independent byte operation
Output Enable (\overline{OE}) for memory expansion
- **Very fast access time**
55ns address access option
30ns \overline{OE} access time
- **Automatic power down to standby mode**
- **TTL compatible three-state output driver**
- **Green package option for TSOP and BGA**

Product Family

Part Number	Package Type	Operating Temperature	Power Supply (Vcc)	Speed	Standby Current (I _{SB}), Max @ 3.0V	Operating Current (I _{CC}), Max
N08T1630C2BZ	48 - BGA	-40°C to $+85^{\circ}\text{C}$	2.7V - 3.6V	55/70ns @ 2.7V	70 μA	3 mA @ 1MHz
N08T1630C2BZ2	Green 48 - BGA					
N08T1630C1BT	44- TSOP2					
N08T1630C1BT2	Green 44- TSOP2					

Pin Configuration (Top View)

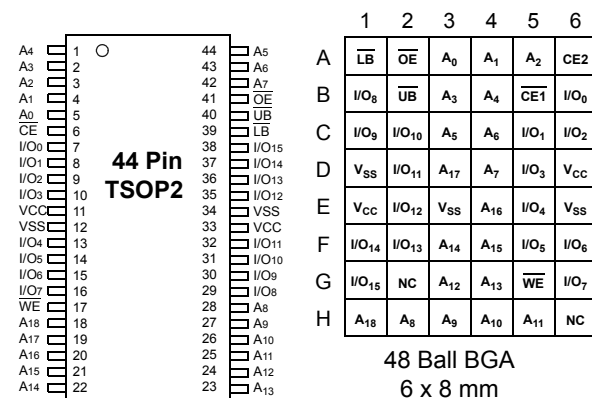

Pin Descriptions

Pin Name	Pin Function
A ₀ -A ₁₈	Address Inputs
\overline{WE}	Write Enable Input
$\overline{CE1}$	Chip Enable 1 Input
$\overline{CE2}$	Chip Enable 2 Input (BGA only)
\overline{OE}	Output Enable Input
\overline{LB}	Lower Byte Enable Input
\overline{UB}	Upper Byte Enable Input
I/O ₀ -I/O ₁₅	Data Inputs/Outputs
V _{CC}	Power
V _{SS}	Ground
NC	Not Connected

Functional Block Diagram

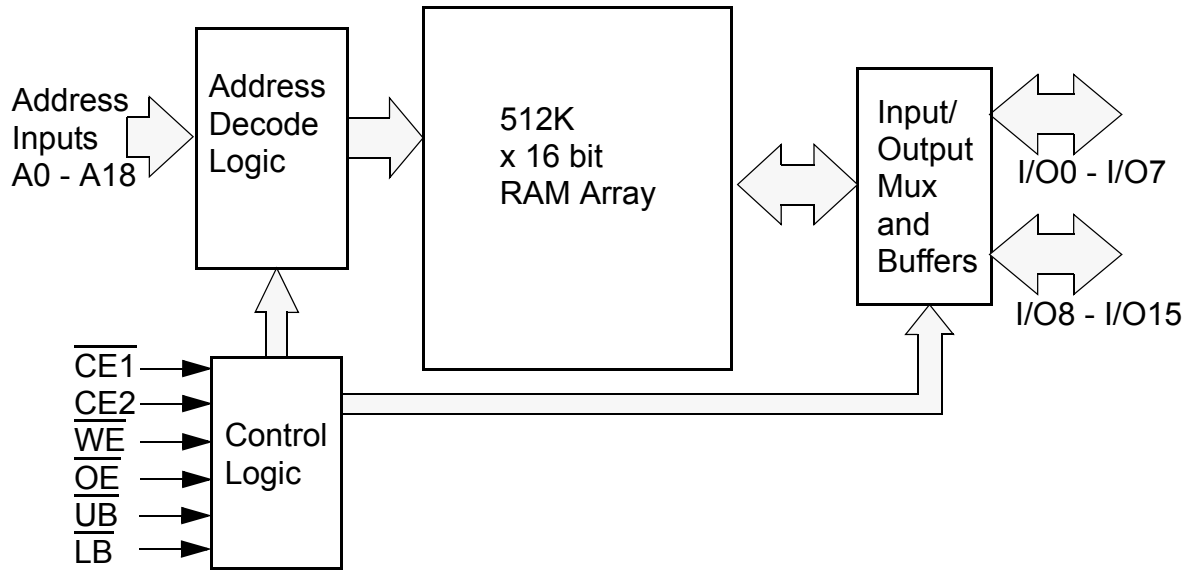

Functional Description

$\overline{CE1}$	$\overline{CE2}^1$	\overline{WE}	\overline{OE}	\overline{UB}	\overline{LB}	I/O ₀ - I/O ₁₅ ²	MODE	POWER
H	X	X	X	X	X	High Z	Standby ³	Standby
X	L	X	X	X	X	High Z	Standby ³	Standby
L	H	X	X	H	H	High Z	Standby ³	Standby
L	H	L	X ⁴	L ²	L ²	Data In	Write	Active
L	H	H	L	L ²	L ²	Data Out	Read	Active
L	H	H	H	L ²	L ²	High Z	Active	Active

- CE2 only applies to BGA package.
- When \overline{UB} and \overline{LB} are in select mode (low), I/O₀ - I/O₁₅ are affected as shown. When \overline{LB} only is in the select mode only I/O₀ - I/O₇ are affected as shown. When \overline{UB} is in the select mode only I/O₈ - I/O₁₅ are affected as shown.
- When the device is in standby mode, control inputs (\overline{WE} , \overline{OE} , \overline{UB} , and \overline{LB}), address inputs and data input/outputs are internally isolated from any external influence and disabled from exerting any influence externally.
- When \overline{WE} is invoked, the \overline{OE} input is internally disabled and has no effect on the circuit.

Capacitance¹

Item	Symbol	Test Condition	Min	Max	Unit
Input Capacitance	C _{IN}	V _{IN} = 0V, f = 1 MHz, T _A = 25°C		8	pF
I/O Capacitance	C _{I/O}	V _{IN} = 0V, f = 1 MHz, T _A = 25°C		8	pF

1. These parameters are verified in device characterization and are not 100% tested

Absolute Maximum Ratings¹

Item	Symbol	Rating	Unit
Voltage on any pin relative to V _{SS}	V _{IN,OUT}	-0.3 to V _{CC} +0.3	V
Voltage on V _{CC} Supply Relative to V _{SS}	V _{CC}	-0.3 to 4.5	V
Power Dissipation	P _D	500	mW
Storage Temperature	T _{STG}	-40 to 125	°C
Operating Temperature	T _A	-40 to +85	°C
Soldering Temperature and Time	T _{SOLDER}	260°C, 10sec	°C

1. Stresses greater than those listed above may cause permanent damage to the device. This is a stress rating only and functional operation of the device at these or any other conditions above those indicated in the operating section of this specification is not implied. Exposure to absolute maximum rating conditions for extended periods may affect reliability.

Operating Characteristics (Over Specified Temperature Range)

Item	Symbol	Test Conditions	Min.	Typ ¹	Max	Unit
Supply Voltage	V _{CC}		2.7	3.0	3.6	V
Input High Voltage	V _{IH}		2.2		V _{CC} +0.3	V
Input Low Voltage	V _{IL}		-0.3		0.6	V
Output High Voltage	V _{OH}	I _{OH} = 0.2mA	V _{CC} -0.4			V
Output Low Voltage	V _{OL}	I _{OL} = -0.2mA			0.4	V
Input Leakage Current	I _{LI}	V _{IN} = 0 to V _{CC}			0.5	μA
Output Leakage Current	I _{LO}	\overline{OE} = V _{IH} or Chip Disabled			0.5	μA
Read/Write Operating Supply Current @ 1 μs Cycle Time ²	I _{CC1}	V _{CC} =3.6 V, V _{IN} =V _{IH} or V _{IL} Chip Enabled, I _{OUT} = 0		3.0	5.0	mA
Read/Write Operating Supply Current @ 70 ns Cycle Time ²	I _{CC2}	V _{CC} =3.6 V, V _{IN} =V _{IH} or V _{IL} Chip Enabled, I _{OUT} = 0		12.0	25.0	mA
Maximum Standby Current	I _{SB1}	V _{IN} = V _{CC} or 0V Chip Disabled t _A = 85°C, V _{CC} = 3.0 V			70.0	μA
Maximum Standby Current	I _{SB2}	V _{IN} = V _{CC} or 0V Chip Disabled t _A = 85°C, V _{CC} = 3.6 V			80.0	μA

1. Typical values are measured at V_{CC}=V_{CC} Typ., T_A=25°C and not 100% tested.

2. This parameter is specified with the outputs disabled to avoid external loading effects. The user must add current required to drive output capacitance expected in the actual system.

Timing

Item	Symbol	-55		-70		Units
		Min.	Max.	Min.	Max.	
Read Cycle Time	t_{RC}	55		70		ns
Address Access Time	t_{AA}		55		70	ns
Chip Enable to Valid Output	t_{CO}		55		70	ns
Output Enable to Valid Output	t_{OE}		30		35	ns
Byte Select to Valid Output	t_{LB}, t_{UB}		55		70	ns
Chip Enable to Low-Z output	t_{LZ}	5		5		ns
Output Enable to Low-Z Output	t_{OLZ}	5		5		ns
Byte Select to Low-Z Output	t_{BLZ}	5		5		ns
Chip Disable to High-Z Output	t_{HZ}	0	20	0	25	ns
Output Disable to High-Z Output	t_{OHZ}	0	20	0	25	ns
Byte Select Disable to High-Z Output	t_{BHZ}	0	20	0	25	ns
Output Hold from Address Change	t_{OH}	10		10		ns
Write Cycle Time	t_{WC}	55		70		ns
Chip Enable to End of Write	t_{CW}	45		55		ns
Address Valid to End of Write	t_{AW}	45		55		ns
Byte Select to End of Write	t_{BW}	45		55		ns
Write Pulse Width	t_{WP}	45		55		ns
Address Setup Time	t_{AS}	0		0		ns
Write Recovery Time	t_{WR}	0		0		ns
Write to High-Z Output	t_{WHZ}		25		25	ns
Data to Write Time Overlap	t_{DW}	40		40		ns
Data Hold from Write Time	t_{DH}	0		0		ns
End Write to Low-Z Output	t_{OW}	5		5		ns

Timing of Read Cycle ($\overline{CE1} = \overline{OE} = V_{IL}, \overline{WE} = CE2 = V_{IH}$)

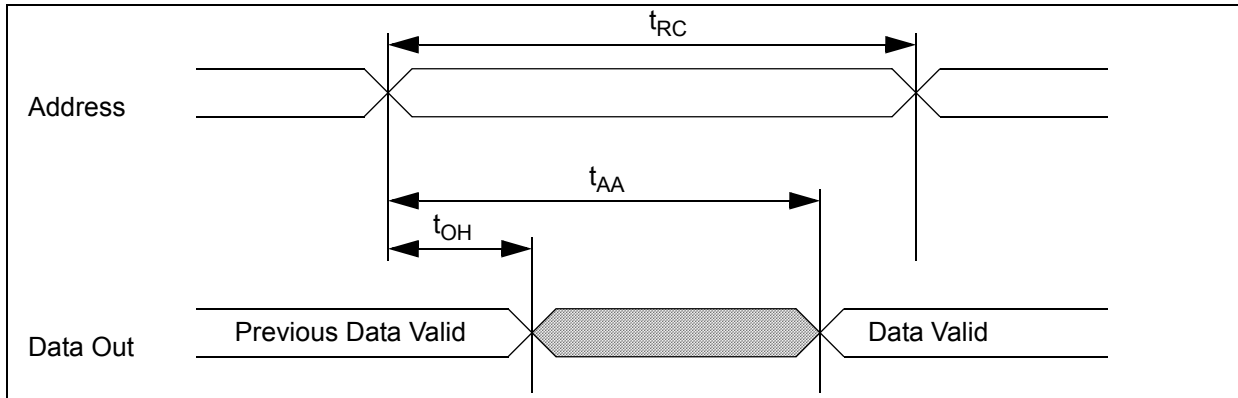

Timing Waveform of Read Cycle ($\overline{WE} = V_{IH}$)

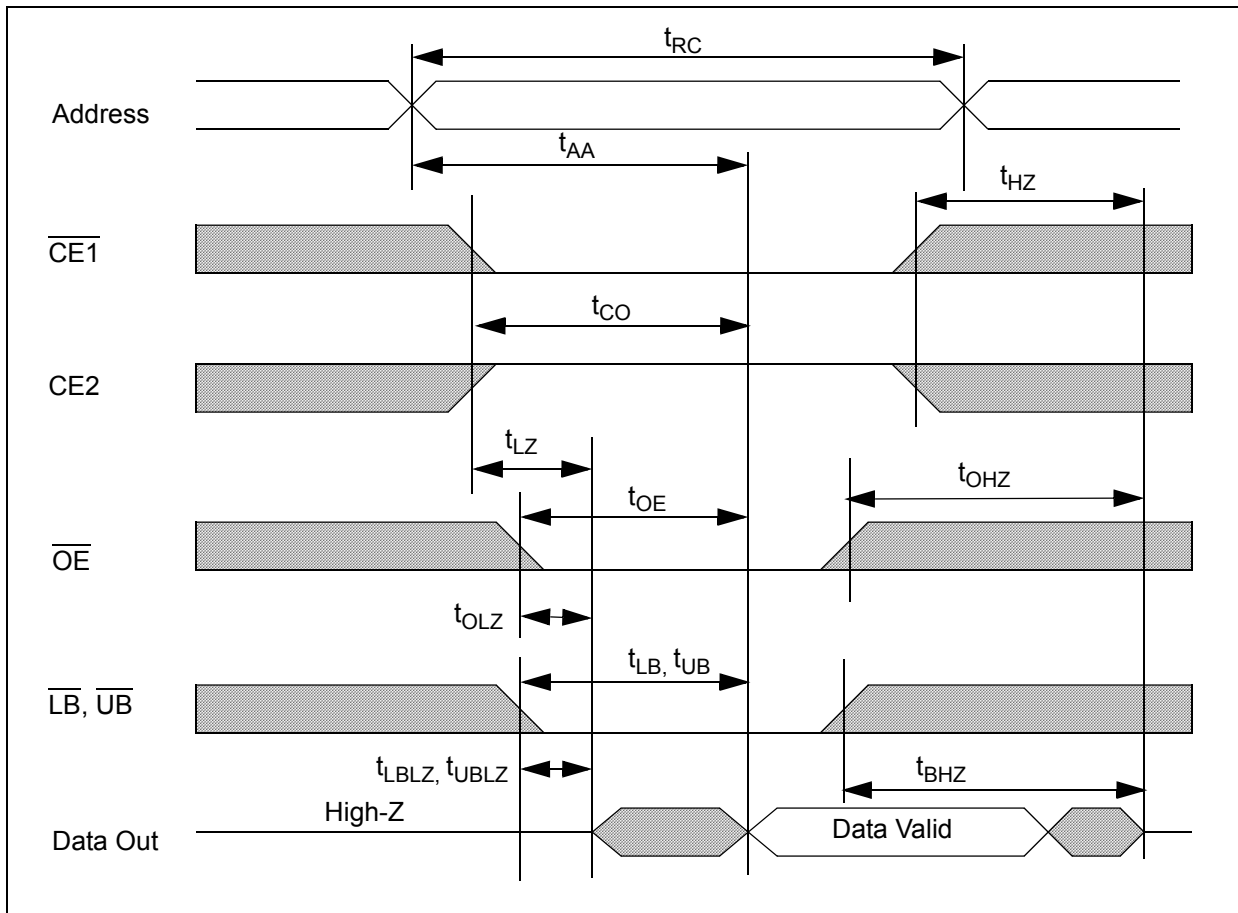

Timing Waveform of Write Cycle (\overline{WE} control)

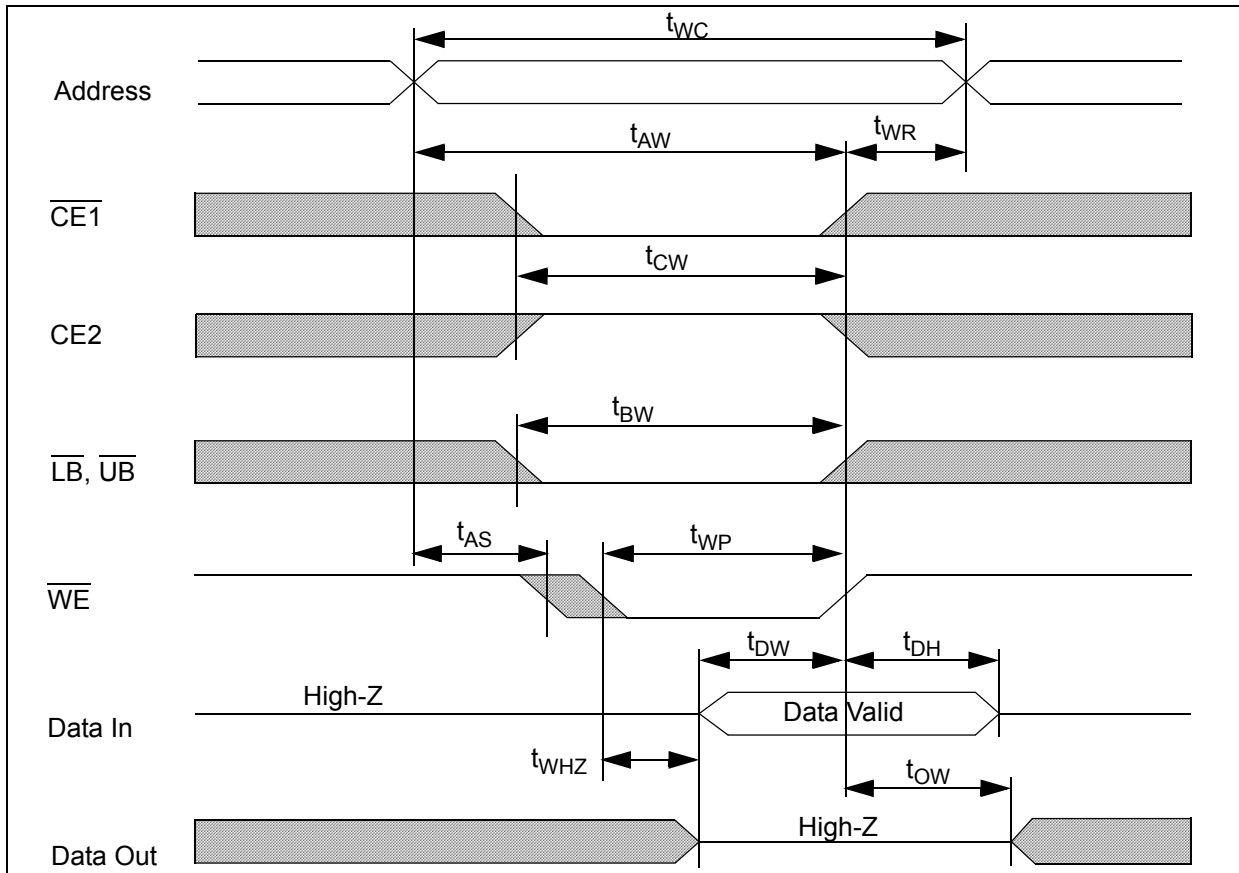

Timing Waveform of Write Cycle ($\overline{CE1}$ Control)

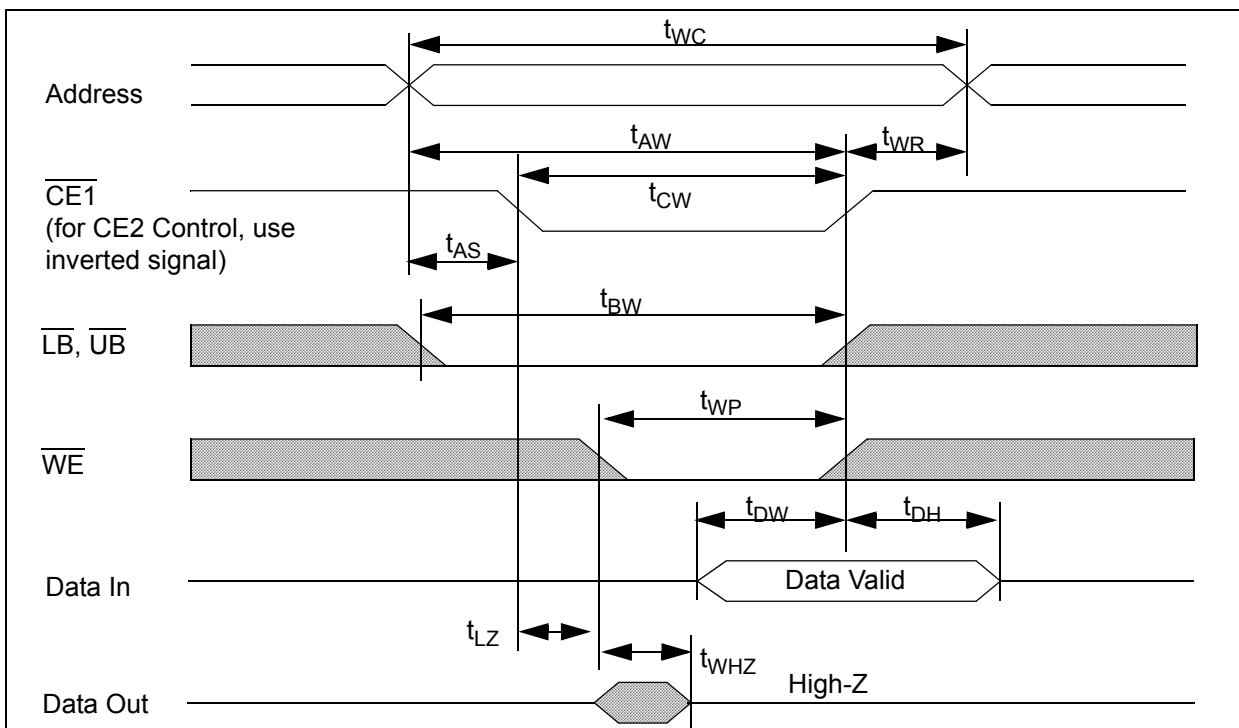

44-Lead TSOP II Package (T44)

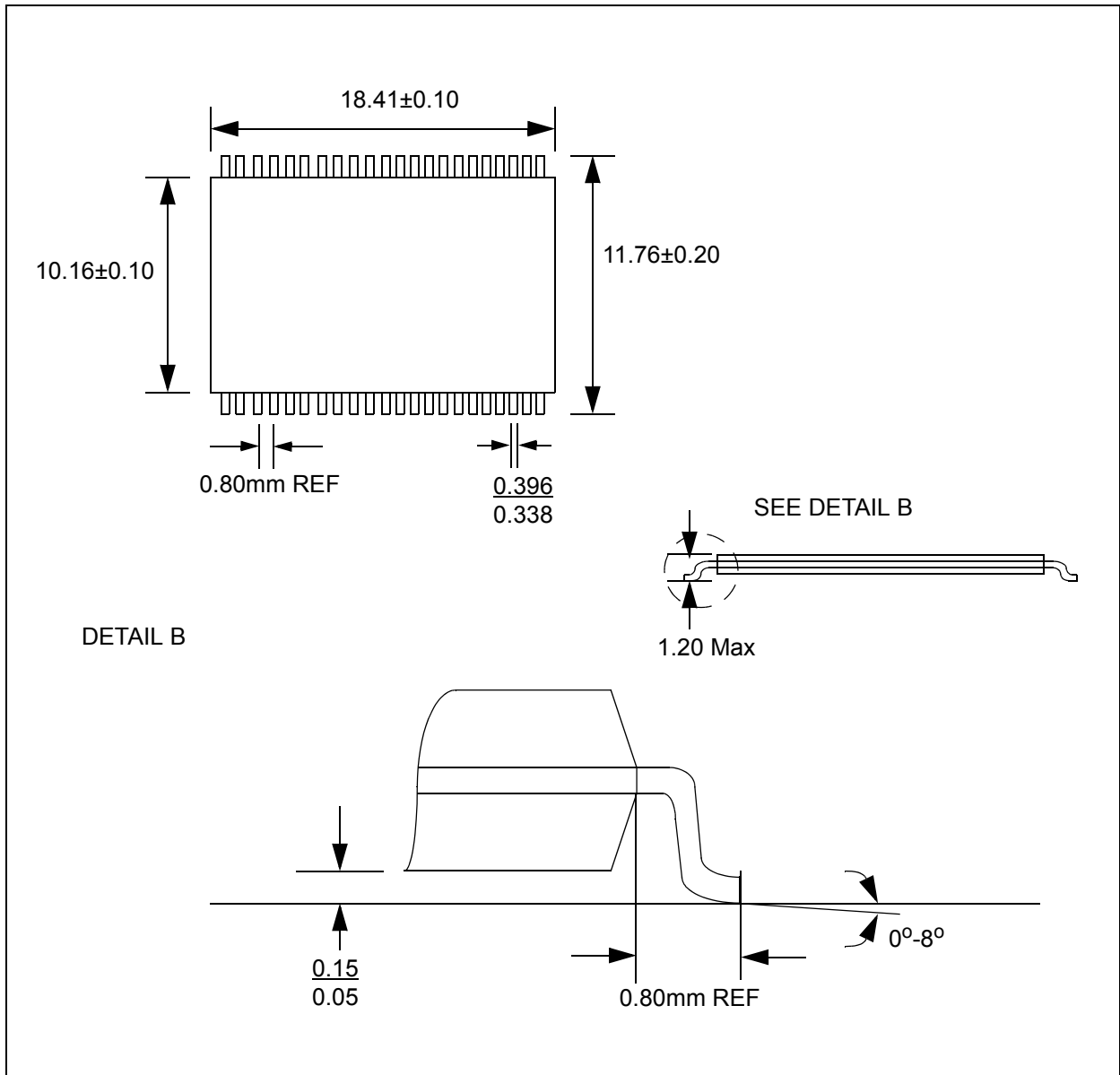

Note:

1. All dimensions in inches (Millimeters)
2. Package dimensions exclude molding flash

Ball Grid Array Package

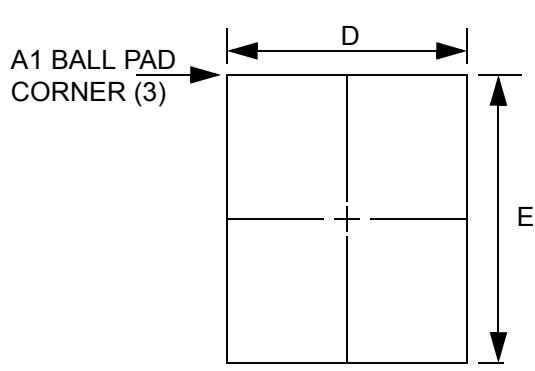

TOP VIEW

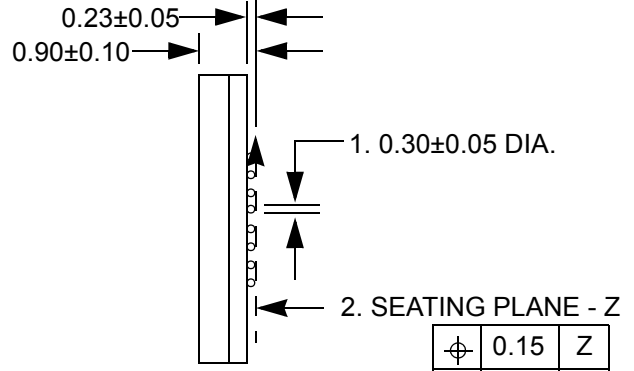

SIDE VIEW

⌀	0.15	Z
⌀	0.08	Z

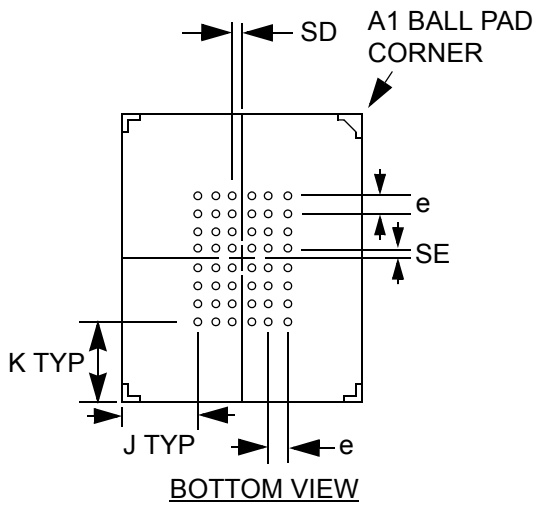

BOTTOM VIEW

1. DIMENSION IS MEASURED AT THE MAXIMUM SOLDER BALL DIAMETER. PARALLEL TO PRIMARY Z.
2. PRIMARY DATUM Z AND SEATING PLANE ARE DEFINED BY THE SPHERICAL CROWNS OF THE SOLDER BALLS.
3. A1 BALL PAD CORNER I.D. TO BE MARKED BY INK.

Dimensions (mm)

D	E	e = 0.75				BALL MATRIX TYPE
		SD	SE	J	K	
6±0.10	8±0.10	0.375	0.375	1.125	1.375	FULL

Ordering Information

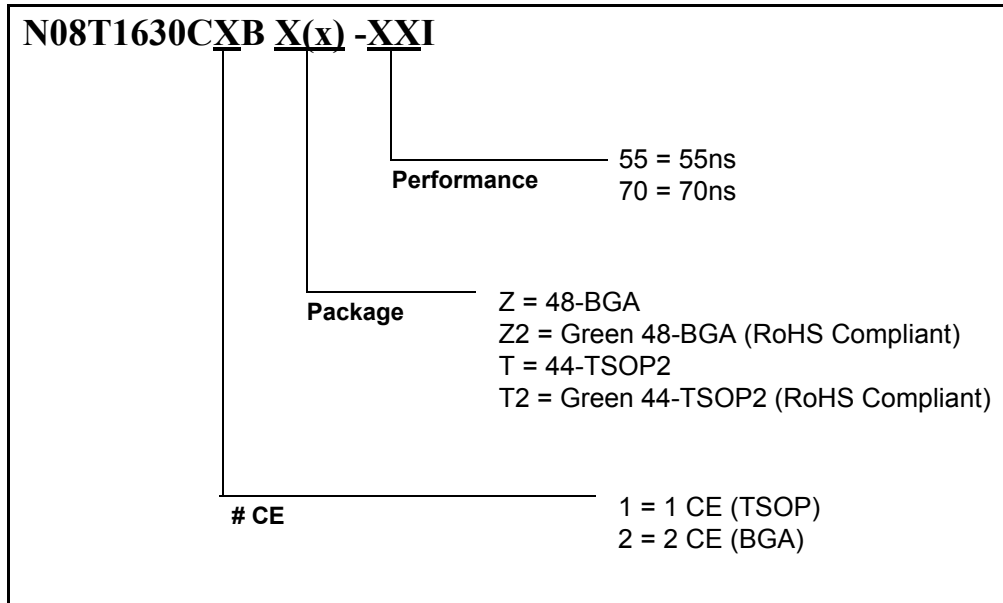

Revision History

Revision	Date	Change Description
A	August 2002	Initial Preliminary Release
B	Sept 2002	Added TSOP option to ordering information
C	November 2002	Added 55ns sort
D	February 2003	Updated BGA package thickness from 1.2mm to 1.0mm
E	April 2003	Updated for dual CE in BGA only
F	September 2003	Change I_{SB} @ 3.0v to 60 μ A Change t_{HZ} to 20ns for 55ns part Change t_{DW} to 40ns for both 55ns and 70ns part
G	November 2003	Change I_{SB} @ 3.0v to 70 μ A
H	January 2005	Added Green package offering

© 2005 Nanoamp Solutions, Inc. All rights reserved.

NanoAmp Solutions, Inc. ("NanoAmp") reserves the right to change or modify the information contained in this data sheet and the products described therein, without prior notice. NanoAmp does not convey any license under its patent rights nor the rights of others. Charts, drawings and schedules contained in this data sheet are provided for illustration purposes only and they vary depending upon specific applications.

NanoAmp makes no warranty or guarantee regarding suitability of these products for any particular purpose, nor does NanoAmp assume any liability arising out of the application or use of any product or circuit described herein. NanoAmp does not authorize use of its products as critical components in any application in which the failure of the NanoAmp product may be expected to result in significant injury or death, including life support systems and critical medical instruments.