

PLEASE CHECK WWW.MOLEX.COM FOR LATEST PART INFORMATION

Part Number: [0436440021](#)
Status: **Active**
Description: 4.20mm (.165") Pitch Mini-Fit Jr.™ BMI Header, Dual Row, Right Angle, 18 Circuits, PA Polyamide Nylon 6/6 94V-0, with Gold (Au) Plating

Documents:

[3D Model](#) [Product Specification PS-5556-002 \(PDF\)](#)
[Drawing \(PDF\)](#) [RoHS Certificate of Compliance \(PDF\)](#)

General

Product Family	PCB Headers
Series	43644
Application	Board-to-Board, Wire-to-Board
Comments	Current = 13A max. per circuit when header is mated to a receptacle loaded with 45750 Mini-Fit Plus HCS™ Crimp Terminal Crimped to 16 AWG wire. . See Molex Product specification PS-5556-002 for additional current de-rating information.
Product Name	Mini-Fit BMI™

Physical

Breakaway	No
Circuits (Loaded)	18
Circuits (maximum)	18
Color - Resin	Natural (White)
Durability (mating cycles max)	30
First Mate / Last Break	No
Glow-Wire Compliant	No
Guide to Mating Part	No
Keying to Mating Part	None
Lock to Mating Part	None
Material - Metal	Brass
Material - Plating Mating	Gold
Material - Plating Termination	Tin
Material - Resin	Nylon
Number of Rows	2
Orientation	Right Angle
PC Tail Length (in)	0.130 In
PC Tail Length (mm)	3.30 mm
PCB Locator	Yes
PCB Retention	None
PCB Thickness Recommended (in)	0.093 In
PCB Thickness Recommended (mm)	2.40 mm
Packaging Type	Tray
Pitch - Mating Interface (in)	0.165 In
Pitch - Mating Interface (mm)	4.20 mm
Plating min: Mating (µin)	30
Plating min: Mating (µm)	0.76
Plating min: Termination (µin)	100
Plating min: Termination (µm)	2.54
Polarized to PCB	Yes
Shrouded	Partial
Stackable	No
Surface Mount Compatible (SMC)	No
Temperature Range - Operating	-40°C to +105°C
Termination Interface: Style	Through Hole

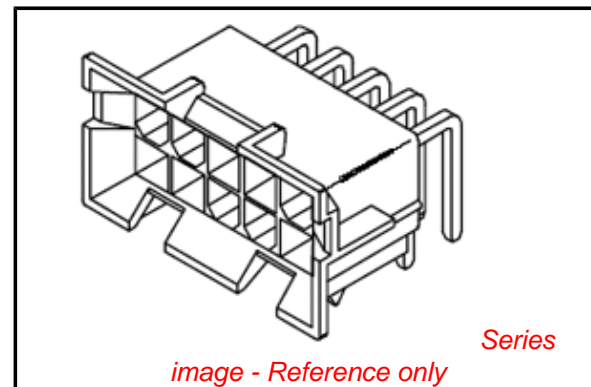

EU RoHS

ELV and RoHS Compliant
REACH SVHC
 Not Reviewed
Halogen-Free Status
 Not Reviewed

China RoHS



Need more information on product environmental compliance?

Email productcompliance@molex.com
 For a multiple part number RoHS Certificate of Compliance, [click here](#)

Please visit the [Contact Us](#) section for any non-product compliance questions.

Search Parts in this Series

[43644Series](#)

Mates With

[44516](#) Slide-and-Lock Receptacle, [42474](#) Receptacle Housing, [44475](#) Mini-Fit HCS™ Receptacle Header, [5557d](#) Receptacle Housing, [42385](#) Receptacle Header

Electrical

Current - Maximum per Contact	13A
Voltage - Maximum	600V

Material Info**Reference - Drawing Numbers**

Packaging Specification	PK-42404-002
Product Specification	PS-5556-002
Sales Drawing	SD-43644-002
Test Summary	TS-5556-002

This document was generated on 05/13/2010

PLEASE CHECK WWW.MOLEX.COM FOR LATEST PART INFORMATION

CIRCUIT SIZE	DIM. 'A'	DIM. 'B'
6	.331 (8.40)	.76 (19.2)
8	.496 (12.60)	.92 (23.4)
10	.661 (16.80)	1.09 (27.6)
12	.827 (21.00)	1.25 (31.8)
14	.992 (25.20)	1.42 (36.0)
16	1.157 (29.40)	1.58 (40.2)
18	1.323 (33.60)	1.75 (44.4)
20	1.488 (37.80)	1.91 (48.6)
22	1.654 (42.00)	2.08 (52.8)
24	1.819 (46.20)	2.24 (57.0)

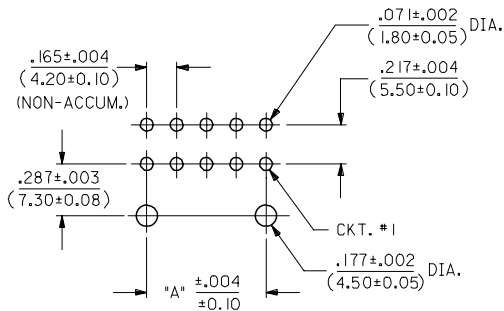
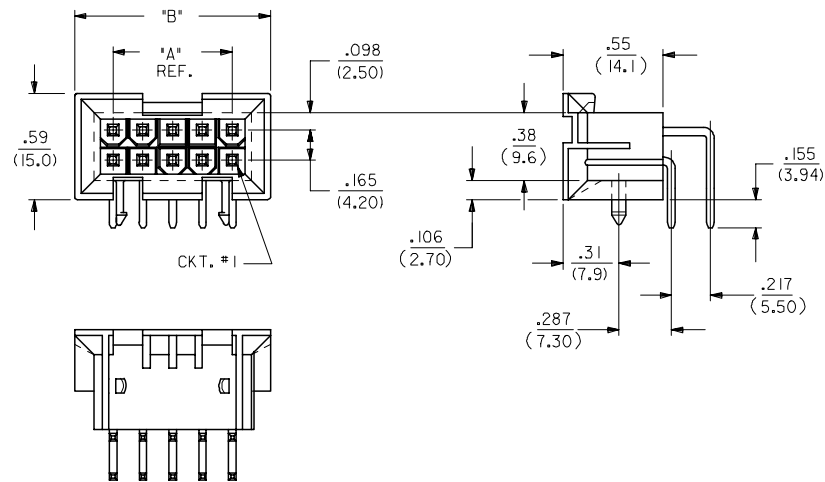

RECOMMENDED HOLE LAYOUT FOR
.101/(2.56) MAX. THICK P.C. BOARD
(VIEWED FROM COMPONENT SIDE)

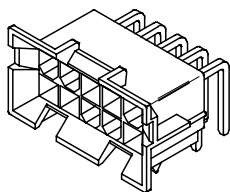

43644****

NOTES:

- HOUSING MATERIAL:
1 = NYLON 6/6, U.L. 94V-0, COLOR: NATURAL.
- TERMINAL MATERIAL: BRASS, ALLOY 260.
- 4-24 CKT. PARTS MATE WITH MINI-FIT JR. RECEPTACLES *5557, *42385 AND *42474. 2 CKT. PART MATES WITH *42385 AND *42474 ONLY.
- PART ALLOWS FOR UP TO .100/(2.54) MISALIGNMENT WITH MATING RECEPTACLE IN ANY DIRECTION. SEE MATING CONNECTOR DRAWINGS FOR SPECIFIC ALLOWANCES.
- DISCOLORATION IN THE BANDOLIER CARRIER AREA OF THE PIN IS INHERENT TO THE PLATING PROCESS AND IS DUE TO THE MASKING EFFECT OF THE CARRIER. THIS DISCOLORATION IS IN A NON-FUNCTIONAL AREA OF THE PIN AND WILL NOT AFFECT THE PERFORMANCE OF THE HEADER ASSEMBLY.
- TERMINAL PLATING:
1 = .000100/(.00254) MIN. BRIGHT TIN OVER .000050/(.00127) MIN. NICKEL OVERALL.
2 = .000030/(.00076) MIN. SELECT GOLD .000100/(.00254) MIN. SELECT MATTE TIN OVER .000050/(.00127) MIN. NICKEL OVERALL.
- PRODUCT SPECIFICATION: PS-5556-002
- CONNECTOR ASSEMBLIES ARE NOT TO BE MATED OR UNMATED WHILE CIRCUITS ARE LIVE.
- THIS HOLE PATTERN DOES NOT PROVIDE FOR LOCKING THE HOUSING TO THE P.C. BOARD
- ITEM NUMBERS PRECEDED BY AN 'X' ARE NOT TOOLED.
- THIS PART CONFORMS TO CLASS B REQUIREMENTS OF COSMETIC SPECIFICATION PS-45499-002.

REV.	DESCRIPTION	QUALITY SYMBOLS	GENERAL TOLERANCES (UNLESS SPECIFIED)		DIMENSION STYLE		SCALE	DESIGN UNITS	THIRD ANGLE PROJECTION
			mm	INCH	IN/MM	METRIC			
1	ADD NOTE 11	▽=0	4 PLACES	± .010	DRAWN BY	AD RATNOL	2:1	METRIC	3
2	DRWNG STEWART 2007/02/22	▽=0	3 PLACES	± .015	DATE	2005/12/05			2
	CHKD: GPOLGAR 2007/02/22		2 PLACES	± 0.25	CHECKED BY	GPOLGAR			1
	APPR: APATEL 2007/02/22		1 PLACE	± 0.38	DATE	2005/12/05			2
			ANGULAR ±1/2°		APPROVED BY	JCOMERC I			1
			DRAFT WHERE APPLICABLE MUST REMAIN WITHIN DIMENSIONS		MATERIAL NO.				
			SEE SHEET 3		DATE	2005/12/05			
			THIS DRAWING CONTAINS INFORMATION THAT IS PROPRIETARY TO MOLEX INCORPORATED AND SHOULD NOT BE USED WITHOUT WRITTEN PERMISSION		DOCUMENT NO.	SD-43644-002			
					SHEET NO.	1 OF 3			

13 12 11 10 9 8 7 6 5 4 3 2 1

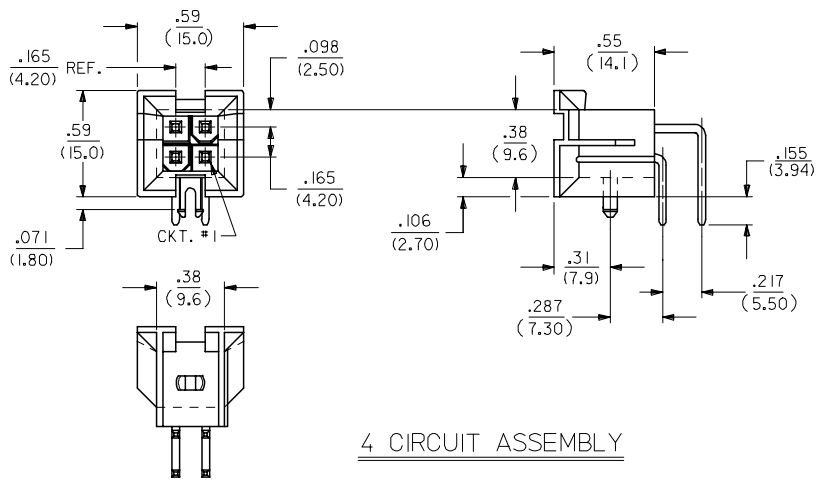

4 CIRCUIT ASSEMBLY

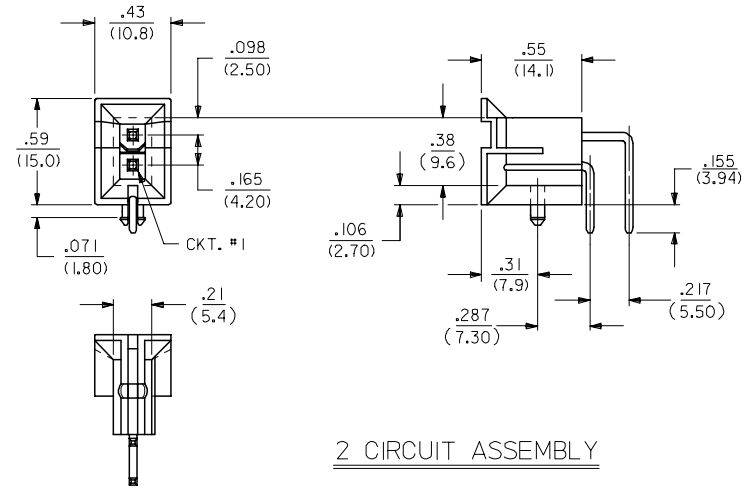

2 CIRCUIT ASSEMBLY

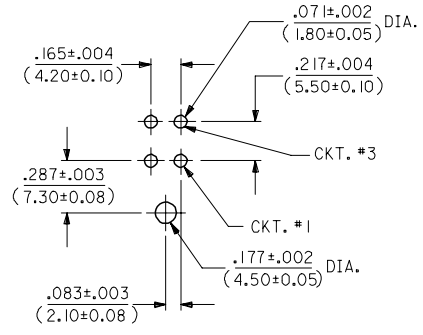

RECOMMENDED HOLE LAYOUT FOR .101/(2.56) MAX. THICK P.C. BOARD (VIEWED FROM COMPONENT SIDE)

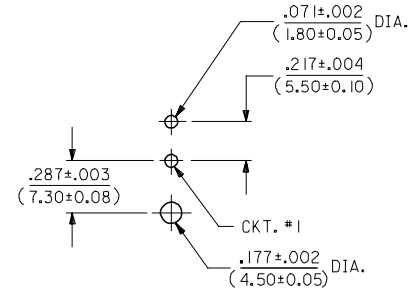

RECOMMENDED HOLE LAYOUT FOR .101/(2.56) MAX. THICK P.C. BOARD (VIEWED FROM COMPONENT SIDE)

SEE SHEET ONE FC NO: UCP2007-2082 2 DRAWING STEWART 2007/02/22 CHKD: GPOLGAR 2007/02/22 APPR: APATEL 2007/02/22 REV DESCRIPTION	QUALITY SYMBOLS ▽=0 ▽=0	GENERAL TOLERANCES (UNLESS SPECIFIED) mm INCH 4 PLACES ± --- ± --- 3 PLACES ± --- ± .010 2 PLACES ± 0.25 ± .015 1 PLACE ± 0.38 ± --- ANGULAR ±1/2°	DIMENSION STYLE IN/MM DRAWN BY DATE AD RATNOL 2005/12/05 CHECKED BY DATE GPOLGAR 2005/12/05 APPROVED BY DATE JCOMERC I 2005/12/05 MATERIAL NO.	SCALE 2:1 DESIGN UNITS METRIC THIRD ANGLE PROJECTION	TITLE MINI-FIT JR BMI RIGHT ANGLE HDR ASSY FOR .094/(2.40) PCB MOLEX INCORPORATED DOCUMENT NO. SD-43644-002 SHEET NO. 2 OF 3	
	DRAFT WHERE APPLICABLE MUST REMAIN WITHIN DIMENSIONS		SEE SHEET 3	THIS DRAWING CONTAINS INFORMATION THAT IS PROPRIETARY TO MOLEX INCORPORATED AND SHOULD NOT BE USED WITHOUT WRITTEN PERMISSION		

12 11 10 9 8 7 6 5 4 3 2 1

J	13	12	11	10	9	8	7	6	5	4	3	2	1
I													
H													
G													
F													
E													
D													
C													
B													
A													

J													
I													
H													
G													
F													
E													
D													
C													
B													
A													

J													
I													
H													
G													
F													
E													
D													
C													
B													
A													

SEE SHEET ONE
 FCC NO: UCP2007-2082
 DRAWING STEWART 2007/02/22
 CHKD: GPOLGAR 2007/02/22
 APPR: APATEL 2007/02/22

QUALITY SYMBOLS

 GENERAL TOLERANCES (UNLESS SPECIFIED)

	mm	INCH
4 PLACES	±.010	±.0004
3 PLACES	±.015	±.0005
2 PLACES	±.020	±.0008
1 PLACE	±.030	±.0012

 ANGULAR ±.0005°
 DRAFT WHERE APPLICABLE
 MUST REMAIN WITHIN DIMENSIONS

DIMENSION STYLE IN/MM
 DRAWN BY ADRATNOL DATE 2005/12/06
 CHECKED BY GPOLGAR DATE 2005/12/06
 APPROVED BY JCOMERC I DATE 2005/12/06
 MATERIAL NO. SEE CHART

SCALE ---
 DESIGN UNITS METRIC
 THIRD ANGLE PROJECTION

TITLE
**MINI-FIT JR BMI RIGHT
 ANGLE HDR ASSY
 FOR .094/(2.40) PCB**
 **MOLEX INCORPORATED**
 DOCUMENT NO. SD-43644-002
 SHEET NO. 3 OF 3