



## 8-BIT CID MICROCONTROLLER

### Table of Contents-

1.	GENERAL DESCRIPTION .....	2
2.	FEATURES .....	2
3.	PIN CONFIGURATION .....	4
4.	PIN DESCRIPTION.....	5
5.	BLOCK DIAGRAM .....	7
6.	FUNCTIONAL DESCRIPTION.....	8
6.1	Memory Organization .....	9
6.2	Special Function Registers .....	12
6.3	Initial State of Registers .....	32
6.4	Instruction .....	33
6.5	Power Management.....	37
6.6	Reset.....	38
6.7	Interrupt.....	38
6.8	Programmable Timers/Counters.....	41
6.9	Serial Port 1 .....	45
6.10	Comparator .....	47
6.11	DTMF Generator.....	47
6.12	FSK Generator.....	48
6.13	I/O Ports.....	50
6.14	Divider.....	50
6.15	Calling Identity Delivery (CID).....	51
7.	APPLICATION CIRCUIT.....	60
8.	ELECTRICAL CHARACTERISTICS .....	66
8.1	Absolute Maximum Ratings* .....	66
8.2	Recommended Operating Conditions .....	66
8.3	DC Characteristics.....	67
8.4	Electrical Characteristics - Gain Control OP-Amplifier .....	68
8.5	AC Characteristics .....	69
9.	PACKAGE DIMENSION .....	72
10.	REVISION HISTORY .....	73



## 1. GENERAL DESCRIPTION

The W925E/C240 is an all in one single 8-bit micro-controller with widely used Calling Identity Delivery (CID) function. The 8-bit CPU core is based on the 8051 family; therefore, all the instructions are compatible to the Turbo 8051 series. The CID part consisted of FSK decoder, DTMF receiver, CPE\* Alert Signal (CAS) detector and Ring detector. Also built-in DTMF generator and FSK generator with baud rate 1200 bps (bits/sec). Using W925E/C240 can easily implement the CID adjunct box and the feature phone or Short Message Service (SMS) phone with CID function. The main features are listed in the next section.

## 2. FEATURES

- **APPLICATION:** The **SMS** phone with CID function and CID adjunct box.
- **CPU:** 8-bit micro-controller is similar to the 8051 family.
  - EEPROM type(E version) operating voltage:
    - μC: Depend on the operating vol. option. Either 2.4 to 3.6V or 3.0 to 5.5V for operating. If 2.4 to 3.6V be selected, the μC operating range is from 2.4 to 3.6V, else if 3.0 to 5.5V be selected, the μC operating range is from 3.0 to 5.5V.
    - CID: 3.0 to 5.5V.
  - MASK type(C version) operating voltage:
    - μC: 2.2 to 5.5V.
    - CID: 3.0 to 5.5V.
- **Dual-clock operation:**
  - Main oscillator: 3.58MHz crystal for CID and DTMF function. And built-in RC oscillator.
  - Sub oscillator: 32768Hz crystal.
  - Main and sub oscillators are enable/disable by bit control individually.
- **ROM:** 256K bytes internal flash EEPROM/MASK ROM type.
  - Up 128K bytes for program ROM.
  - Total 256K bytes for look-up table ROM.
  - Separate 256K into 4 pages, each page is 64K addressable.
- **RAM:**
  - 256 bytes on chip scratch-pad RAM.
  - 8K bytes on chip RAM for MOVX instruction.
- **CID**
  - Compatible with Bellcore TR-NWT-000030 & SR-TSV-002476, British Telecom(BT) SIN227, U.K. Cable Communication Association(CCA) specification.
  - FSK modulator/demodulator: for Bell 202 and ITU-T V.23 FSK with 1200-baud rate.
  - CAS detector: for dual tones of Bellcore CAS and BT Idle State and Loop State Dual Tone Alert Signal (DTAS).
  - DTMF generator/receiver;
  - Ring detector: for line reversal for BT, ring burst for CCA or ring signal for Bellcore.
  - Two independent OP amps with adjustable gain for Tip/Ring and Telephone Hybrid connections.



- **I/O:** 40 I/O pins.
  - P0: Bit and byte addressable. I/O mode can be bit controlled. Open drain type.
  - P1~P3: Bit and byte addressable. Pull high and I/O mode can be bit controlled.
  - P4: Byte addressable. Pull high and I/O mode can be bit controlled.
- **Note:** "CPE\*" Customer Premises Equipment
- **Power mode:**
  - **Dual-clock slow operation mode:** System is operated by the sub-oscillator ( $F_{osc}=F_s$  and  $F_m$  is stopped)
  - **Idle mode:** CPU hold. The clock to the CPU is halted, but the interrupt, timer and watchdog timer block work normally but CID function is disabled.
  - **Power down mode:** All activity is completely stopped and power consumption is less than  $1 \mu A$ .
- **Timer:** 2 13/16-bit timers, or 8-bit auto-reload timers, that are Timer0 and Timer1.
- **Watchdog timer:** WDT can be programmed by the user to serve as a system monitor.
- **Interrupt:** 11 interrupt sources with two levels of priority.
  - 4 interrupts from INT0, INT1, INT2 and INT3.
  - 2 interrupts from Timer0, Timer1.
  - 1 interrupt from Serial port.
  - 1 interrupt from CID.
  - 1 interrupt from 13/14-bit Divider.
  - 1 interrupt from Comparator.
  - 1 interrupt from Watch Dog Timer.
- **Divider:** 13/14 bit divider, clock source from sub-oscillator, therefore, DIVF set every 0.25/0.5 second.
- **Comparator:**
  - Comparator: 1 analog inputs from VNEG pin, 2 reference input pins, one is from VPOS pin and another is from internal regulator output.
- **Serial port:**
  - An 8-bit serial transceiver with SCLK and SDATA.
- **Package:**
  - 100pin LQFP: The part numbers are W925E240 & W925C240
  - Lead free 100pin LQFP: The part numbers are W925E240FG & W925G240

## 3. PIN CONFIGURATION

Figure 3-1 shows the pin assignment. The package type is 100pin QFP.

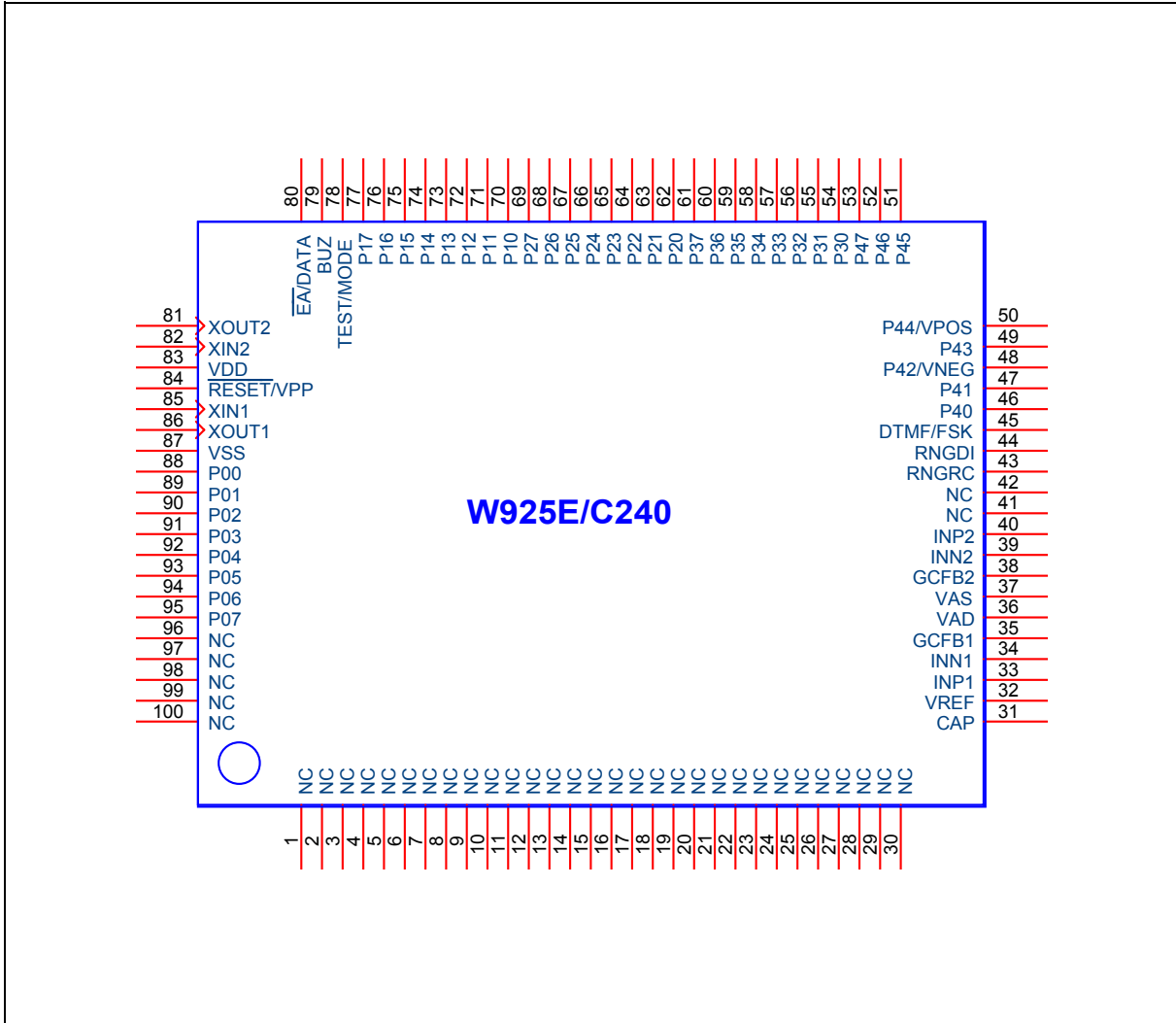

Figure 3-1 W925E/C240 Pin Configuration



#### 4. PIN DESCRIPTION

NAME	I/O	DESCRIPTION
TEST/MODE	I/O	TEST pin. In E version (EEPROM type), it works as a Mode pin to select programming mode. In C version (Mask type), this pin with internal pull-low resistor.
$\overline{EA}$ /DATA	I, I/O	Set high for normal function. In E version, it works as a Data pin. In C version, this pin with internal pull-high resistor.
$\overline{RESET}$ /VPP	I	RESET pin. A low pulse causes the whole chip reset. In E version, this pin works as a VPP pin, which is a supply programming voltage. In C version, this pin with internal pull-high resistor.
RNGDI	I	Ring Detect Input (Schmitt trigger input). Used for ring detection and line reversal detection. Must maintain a voltage between VAD and VAS.
RNGRC	O	Ring RC (Open drain output and Schmitt trigger input). Used to set the time interval from the end of RNGDI pin to the inactive condition of the RNGON pin. An external resistor must connected to VAD and a capacitor connected to $V_{SS}$ , the time interval is the RC time constant.
CAP	O	Must be connected 0.1 $\mu$ F capacitor to $V_{SS}$ .
VREF	O	Reference Voltage. Nominally, $V_{DD}/2$ is used to bias the input of the gain control op-amp.
GCFB1	O	Op-amp1 Feed-back Gain Control signal. Select the input gain by connecting this pin and the INN1 pin with feedback resistor. It is recommended that the op-amp1 be set to unity gain.
INN1	I	Inverting Input of the gain control op-amp1.
INP1	I	Non-inverting Input of the gain control op-amp1.
GCFB2	O	Op-amp2 Feed-back Gain Control signal. Select the input gain by connecting this pin and the INN2 pin with feedback resistor. It is recommended that the op-amp2 be set to unity gain.
INN2	I	Inverting Input of the gain control op-amp2.
INP2	I	Non-inverting Input of the gain control op-amp2.
VAD	I	Analog voltage supply.
VAS	I	Analog ground.
$V_{DD}$	I	Digital voltage supply.
$V_{SS}$	I	Digital ground.
XOUT1	O	Output pin for main-oscillator. Connected to 3.58MHz crystal for CID function.
XIN1	I	Input pin for main-oscillator. Connected to 3.58MHz crystal for CID function.



Pin Description, continued

NAME	I/O	DESCRIPTION
XOUT2	O	Output pin for sub-oscillator. Connected to 32.768KHz crystal only. Suggest to add an external capacitor about 10~30pF to ground(VSS) for the accuracy of the oscillator.
XIN2	I	Input pin for sub-oscillator. Connected to 32.768KHz crystal only. Suggest to add an external capacitor about 10~30pF to ground(VSS) for the accuracy of the oscillator.
DTMF/FSK	O	FTE=0, Dual-Tone Multi-Frequency(DTMF) signal output FTE=1, FSK signal output
BUZ	O	Buzzer output pin. If buzzer function is disabled, BUZ pin is in floating state.
P00-P07	I/O	Input/output port0. Port0 data can be bit controlled. The I/O mode is controlled by P0IO register. Port0 is open drain type when it is configured as output mode.
P10-P17	I/O	Input/output port1 with pull high resistors. Port1 data can be bit controlled. The I/O mode is controlled by P1IO register. The P10-P13 and P14-P17 indicate the external interrupt pins(INT2 and INT3)
P20-P27	I/O	Input/output port2 with pull high resistors. Port2 data can be bit controlled. The I/O mode is controlled by P2IO register.
P30-P37	I/O	Input/output port3 with pull high resistors. Port3 data can be bit controlled. The I/O mode is controlled by P3IO register. The special function of port3 is referred to the description of P3 register.
P40-P47	I/O	Contents are byte controlled. Pull high and I/O mode can be bit controlled. The special function of P4 is referred to the description of P4 register.
VPOS, VNEG	I	The comparator V+, V- analog input pins. Share pin with P4.2 and P4.4

5. BLOCK DIAGRAM

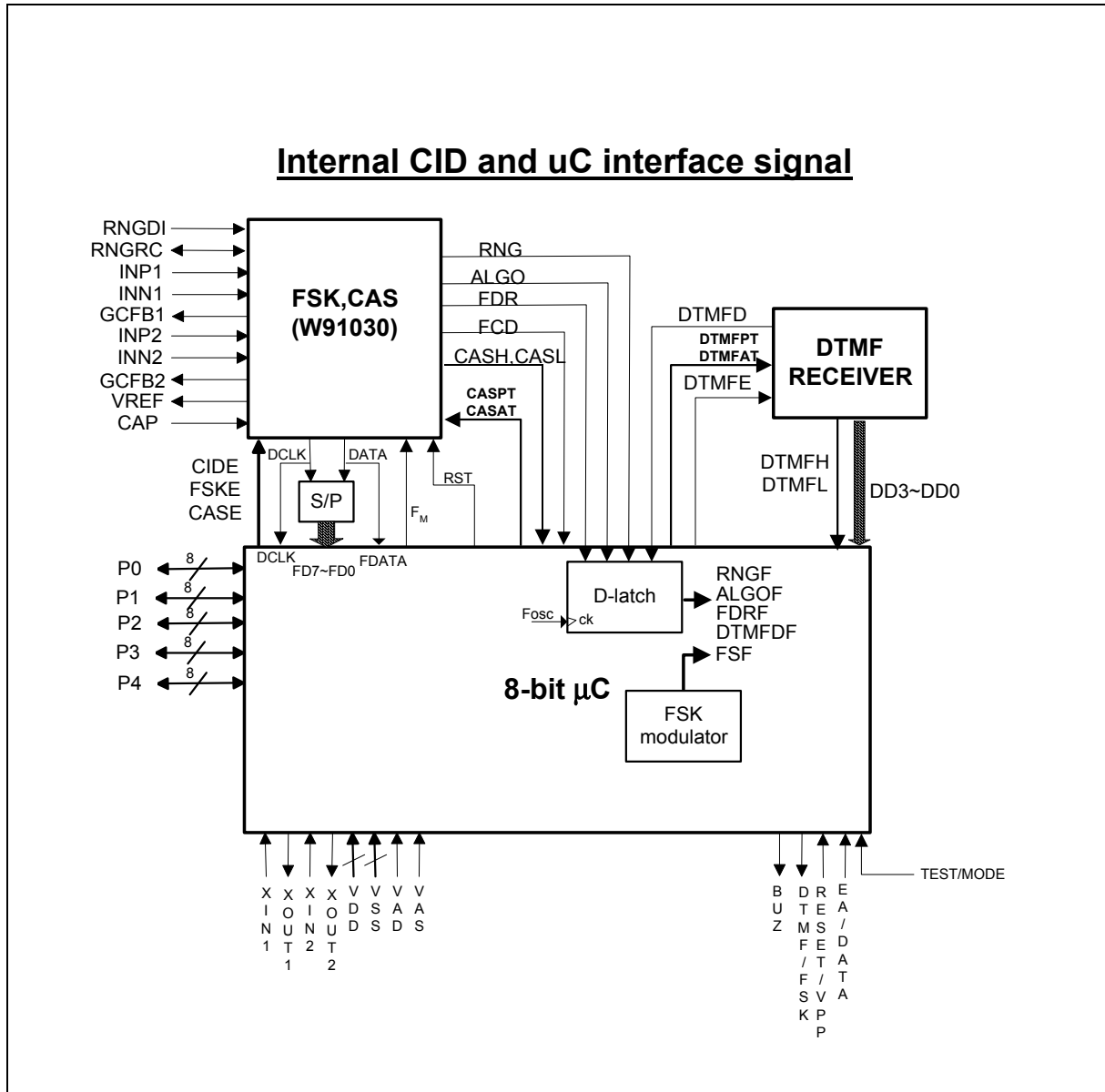



## 6. FUNCTIONAL DESCRIPTION

The W925E/C240 is an 8-bit micro-controller with CID function. The 8-bit micro-control has the same instruction set as the 8051 family, with one addition: DEC DPTR (op-code A5H, the DPTR is decreased by 1). In addition, the W925E/C240 contains on-chip 8K bytes MOVX RAM.

### ROM

There are 256K bytes EEPROM/MASK ROM. Only 128K bytes EEPROM/MASK ROM is used for program code. The completely 256K bytes EEPROM/MASK ROM can be used for the look-up table memory.

### On-chip Data RAM

The W925E/C240 has 8K normal RAM which address is from 0000H to 1FFFH. It only can be accessed by MOVX instruction; this on-chip RAM is optional under software control. The on-chip data RAM is not used for executable program memory. There is no conflict or overlap among the 256 bytes scratchpad RAM and the 8K Bytes MOVX RAM as they use different addressing modes and separate instructions.

### CID

The CID functions include the FSK decoder, CAS detector, and DTMF decoder and ring detector.

### FSK Modulator

Support ITU-T V.23 and Bellcore 202 FSK transmit modulated signal.

### DTMF Modulator

The W925E/C240 built-in dual tone multi-frequency generator.

### I/O Ports:

The W925E/C240 has five 8-bit I/O ports giving 40 lines. Port0 to Port3 can be used as an 8-bit general I/O port with bit-addressable. The I/O mode of each port is controlled by PxIO registers. Port1 to Port4 have internal pull high resistors enabled/disabled by PxH registers. Port0 is open-drain type in output mode.

### Serial I/O Port

The serial port, through P4.0 (SCLK) and P4.1 (SDATA), is an 8-bit synchronous serial I/O interface.

### Timers

The W925E/C240 has two 13/16-bit timers or an 8 bits auto-reload timers. An independent watchdog timer is used as a system monitor or as a very long time period timer. A divider can produce the divider interrupt in every period of 0.5S or 0.25S.

### Comparator

The W925E/C240 has an internal comparator with one external analog signal input path VNEG and an external path VPOS or a regulator voltage for the reference input REF1.

### Interrupts

The W925E/C240 provides 11 interrupt resources with two priority level, including 4 external interrupt sources, 2 timer interrupts, 1 CID interrupt, 1 divider interrupt, 1 serial port interrupt, 1 comparator interrupt and 1 watchdog timer interrupt.





## Power Management

The W925E/C240 has IDLE and POWER DOWN modes of operation. In the IDLE mode, the clock to the CPU core is stopped however the functions of the timers, divider, CID and interrupts are active continuously. In the POWER DOWN mode, both of the system clock stop oscillating and the chip operation is completely stopped. POWER DOWN mode is the state of the lowest power consumption.

## 6.1 Memory Organization

The W925E/C240 separates the memory into two separate sections, the Program Memory and the Data Memory. The Program Memory is used to store the instruction op-codes and look-up table data, while the Data Memory is used to store data or for memory mapped devices.

### Program Memory

The Program Memory on the W925E/C240 can be up to 256K bytes that are divided into 4 pages, each page has the size of 64K bytes. The upper 128K bytes are used to store the op-codes and the whole 256K can be used to store look-up table data. Because the op-code is 64K addressable, a PG bit in PAGE register decides which ROM page between page0, page1 is enabled, and the ALU fetches the op-code from the selected ROM page. If PG=0, ALU fetches the op-code from page0. If PG=1, ALU fetches the op-code from page1. When MOVC instruction is executed, ALU fetches the look-up table data according the indication of LT1 and LT0 bits. The value of LT1 and LT0 indicates which ROM page is active for look-up table instruction.

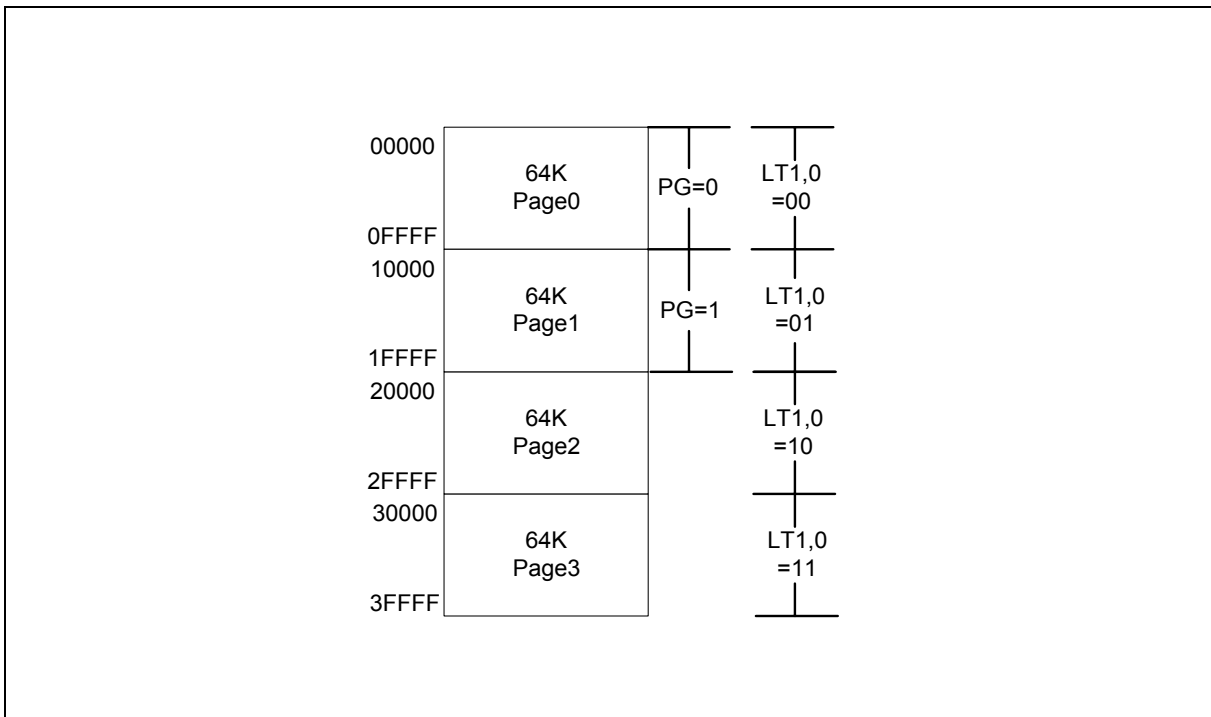

Figure 6-1 Program Memory Map

## Data Memory

The W925E/C240 contains on-chip 8K MOVX RAM of Data Memory, which can only be accessed by MOVX instructions from the address 0000H to 1FFFH. In addition, the W925E/C240 has 256 bytes of on-chip scratchpad RAM. This can be accessed either by direct addressing or by indirect addressing. There are also Special Function Registers (SFRs), which can only be accessed by direct addressing. Since the scratchpad RAM is only 256 bytes, it can be used only when data contents are small. In the event that larger data contents are present, the only one selection is on-chip MOVX RAM. The on-chip MOVX RAM can only be accessed by a MOVX instruction. However, the on-chip RAM has the fastest access times. The memory map is shown Figure 6-2 and Figure 6-3 shows the scratched-pad RAM/register addressing.

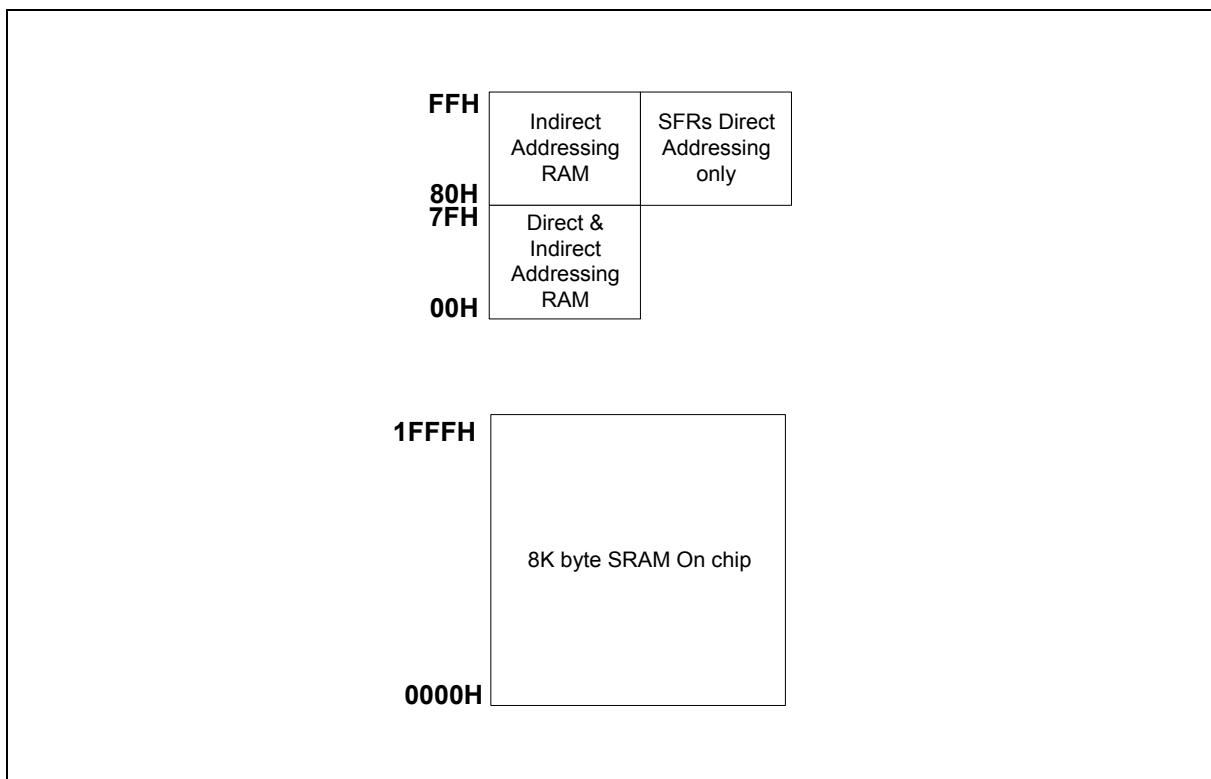

Figure 6-2 memory map

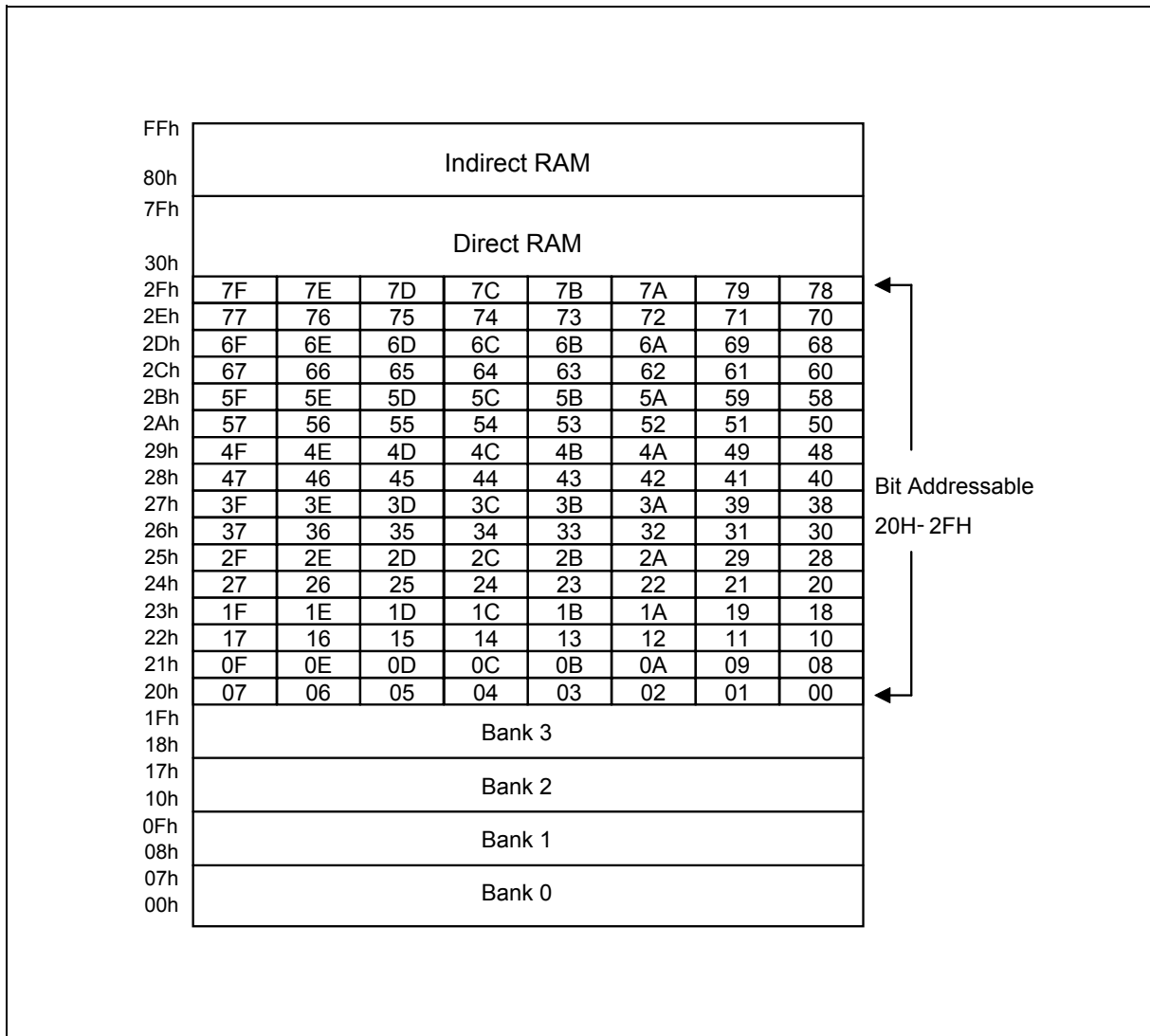

Figure 6-3 Scratchpad RAM/Register Addressing



## 6.2 Special Function Registers

The W925E/C240 uses Special Function Registers (SFRs) to control and monitor peripherals and their Modes.

The SFRs reside in the register locations 80-FFh and accessed by direct addressing only. Some of the SFRs are bit addressable. This is very useful in cases where one wishes to modify a particular bit without changing the others. The SFRs that are bit addressable are those whose addresses end in 0 or 8. The list of SFRs is as follows. The table is condensed with eight locations per row. Empty locations indicate that there are no registers at these addresses. The content of reserved bits or registers is not guaranteed.

**Table 1 Special Function Register Location Table**

F8	EIP	CIDGD	CIDGA					
F0	B							
E8	EIE							
E0	ACC							
D8	WDCON							
D0	PSW							
C8	DIVC							
C0	SCON1	SBUF1	REGVC		PMR	STATUS	FSKTC	FSKTB
B8	IP		DTMFG	COMPR	IRC1	IRC2	CASPT	CASAT
B0	P3	CIDR	CIDFG	CIDPCR	FSKDR	DTMFDR	DTMFPT	DTMFAT
A8	IE						P4IO	
A0	P2	HB	P4H				P4	
98				P1EF		P1H	P2H	P3H
90	P1	EXIF	RPAGE	P1SR	P0IO	P1IO	P2IO	P3IO
88	TCON	TMOD	TL0	TL1	TH0	TH1	CKCON1	CKCON2
80	P0	SP	DPL	DPH	DPL1	DPH1	DPS	PCON

**Note:** The SFRs in the column with dark borders are bit-addressable.

A brief description of the SFRs now follows.

### PORT 0

(initial=FFh, input mode)

Bit:	7	6	5	4	3	2	1	0
	P0.7	P0.6	P0.5	P0.4	P0.3	P0.2	P0.1	P0.0

Mnemonic: P0

Address: 80h

P0: P0 can be selected as input or output mode by the P0IO register. At initial reset, P0IO is set to FFh, P0 is used as input mode. When P0IO is set to 0, the P0 is used as CMOS open drain mode.



## STACK POINTER

(initial=07H)

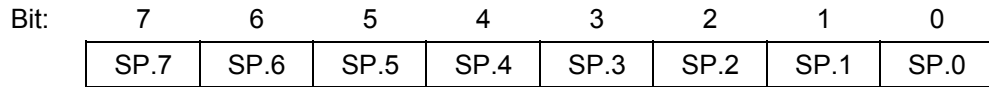

Mnemonic: SP

Address: 81h

SP: The Stack Pointer stores the scratchpad RAM address where the stack begins. In other words, it always points to the top of the stack.

## DATA POINTER LOW

(initial=00H)

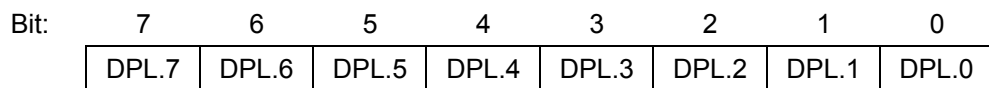

Mnemonic: DPL

Address: 82h

DPL: This is the low byte of the standard 8052 16-bit data pointer.

## DATA POINTER HIGH

(initial=00H)

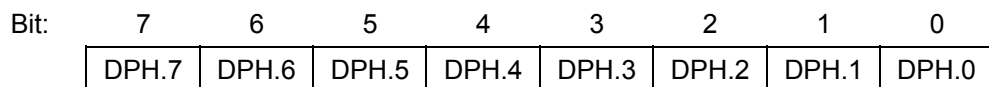

Mnemonic: DPH

Address: 83h

DPH: This is the high byte of the standard 8052 16-bit data pointer.

## DATA POINTER LOW1

(initial=00H)

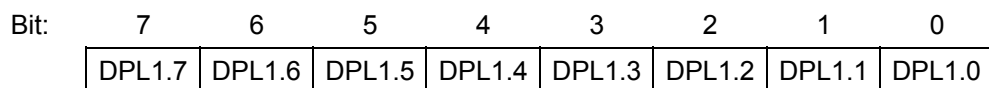

Mnemonic: DPL1

Address: 84h

DPL1: This is the low byte of the new additional 16-bit data pointer. That has been added to the W925E/C240. The user can switch between DPL, DPH and DPL1, DPH1 simply by setting register DPS.0 = 1. The instructions that use DPTR will now access DPL1 and DPH1 in place of DPL and DPH. If they are not required, they can be used as conventional register locations by the user.

## DATA POINTER HIGH1

(initial=00H)

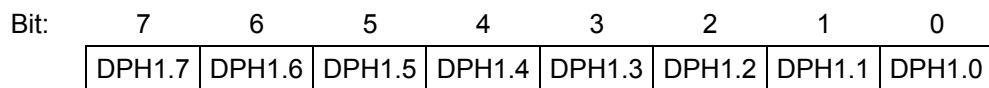

Mnemonic: DPH1

Address: 85h

DPH1: This is the high byte of the new additional 16-bit data pointer. That has been added to the W925E/C240. The user can switch between DPL, DPH and DPL1, DPH1 simply by setting register DPS = 1. The instructions that use DPTR will now access DPL1 and DPH1 in place of DPL and DPH. If they are not required, they can be used as conventional register locations by the user.



## DATA POINTER SELECT

(initial=00H)

Bit:	7	6	5	4	3	2	1	0
	-	-	-	-	-	-	-	DPS.0

Mnemonic: DPS

Address: 86h

DPS.0: This bit is used to select either the DPL,DPH pair or the DPL1,DPH1 pair as the active Data Pointer. When set to 1, DPL1,DPH1 will be selected, otherwise DPL,DPH will be selected.

DPS.1-7: These bits are reserved, but will read 0.

## POWER CONTROL

(initial=00H)

Bit:	7	6	5	4	3	2	1	0
	-	-	-	IDLT	GF1	GF0	PD	IDL

Mnemonic: PCON

Address: 87h

IDLT: This bit controls the idle mode type. In idle mode when idle mode is released by any interrupt, if IDLT=1 it will not jump to the corresponding interrupt; if IDLT=0 it will jump to the corresponding interrupt.

GF1-0: These two bits are general-purpose user flags.

PD: Setting this bit causes the W925E/C240 to go into the POWER DOWN mode. In this mode, all the clocks are stopped and program execution is frozen. Power down mode can be released by INT0~INT3 and ring detection of CID interrupt.

IDL: Setting this bit causes the W925E/C240 to go into the IDLE mode. The type of idle mode is selected by IDLT. In this mode the clocks to the CPU are stopped, so program execution is frozen. However, the clock path to the timers blocks and interrupt blocks is not stopped, and these blocks continue operating.

## TIMER CONTROL

(initial=00H)

Bit:	7	6	5	4	3	2	1	0
	TF1	TR1	TF0	TR0	IE1	IT1	IE0	IT0

Mnemonic: TCON

Address: 88h

TF1: Timer 1 overflows flag. This bit is set when Timer 1 overflows. It is cleared automatically when the program does a timer 1 interrupt service routine. Software can also set or clear this bit.

TR1: Timer 1 runs control. This bit is set or cleared by software to turn timer on or off.

TF0: Timer 0 overflows flag. This bit is set when Timer 0 overflows. It is cleared automatically when the program does a timer 0 interrupt service routine. Software can also set or clear this bit.

TR0: Timer 0 runs control. This bit is set or cleared by software to turn timer on or off.

IE1: Interrupt 1 edge detects: Set by hardware when an edge/level is detected on  $\overline{INT1}$ . This bit is cleared by hardware when the service routine is vectored to only if the interrupt was edge triggered. Otherwise, it follows the pin.

IT1: Interrupt 1 type control: Set/cleared by software to specify falling edge/ low level triggered external inputs.



- IE0: Interrupt 0 edge detects: Set by hardware when an edge/level is detected on  $\overline{INT0}$ . This bit is cleared by hardware when the service routine is vectored to only if the interrupt was edge triggered. Otherwise, it follows the pin.
- IT0: Interrupt 0 type control. Set/cleared by software to specify falling edge/ low level triggered external inputs.

## TIMER MODE CONTROL

(initial=00H)

Bit:	7	6	5	4	3	2	1	0
	GATE	C/ $\overline{T}$	M1	M0	GATE	C/ $\overline{T}$	M1	M0

Mnemonic: TMOD

Address: 89h

Bit7~4 control timer 1, bit3~0 control timer0

GATE: Gating control. When this bit is set, Timer x is enabled only while  $\overline{INTx}$  pin is high and TRx control bit is set. When cleared, Timer x is enabled whenever TRx control bit is set.

C/ $\overline{T}$ : Timer or Counter Select. When cleared, the timer is incremented by internal clocks. When set, the timer counts high-to-low edges of the Tx pin.

**Note:** X is either 0 or 1.

M1, M0: Mode Select bits:

M1	M0	Mode
0	0	Mode 0: 13-bits timer
0	1	Mode 1: 16-bits timer
1	0	Mode 2: 8-bits with auto-reload from Thx
1	1	Reserved

## TIMER 0 LOW BYTE

(initial=00H)

Bit:	7	6	5	4	3	2	1	0
	TL0.7	TL0.6	TL0.5	TL0.4	TL0.3	TL0.2	TL0.1	TL0.0

Mnemonic: TL0

Address: 8Ah

TL0.7-0: Timer 0 low byte register.

## TIMER 1 LOW BYTE

(initial=00H)

Bit:	7	6	5	4	3	2	1	0
	TL1.7	TL1.6	TL1.5	TL1.4	TL1.3	TL1.2	TL1.1	TL1.0

Mnemonic: TL1

Address: 8Bh

TL1.7-0: Timer 1 low byte register.



## TIMER 0 HIGH BYTE

(initial=00H)

Bit:	7	6	5	4	3	2	1	0
	TH0.7	TH0.6	TH0.5	TH0.4	TH0.3	TH0.2	TH0.1	TH0.0

Mnemonic: TH0

Address: 8Ch

TH0.7-0: Timer 0 high byte register.

## TIMER 1 HIGH BYTE

(initial=00H)

Bit:	7	6	5	4	3	2	1	0
	TH1.7	TH1.6	TH1.5	TH1.4	TH1.3	TH1.2	TH1.1	TH1.0

Mnemonic: TH1

Address: 8Dh

TH1.7-0: Timer 1 high byte register.

## CLOCK CONTROL1

(initial=00H)

Bit:	7	6	5	4	3	2	1	0
	WD1	WD0	T1S1	T1S0	T0S1	T0S0	DIVS	$\bar{M}/S$

Mnemonic: CKCON1

Address: 8Eh

WD1-0: Watchdog timer mode select bits: These bits determine the time-out period for the watchdog timer. In all four time-out options the reset time-out is 512 clocks more than the interrupt time-out period.

WD1	WD0	Interrupt time-out	Reset time-out
0	0	$F_{osc}/2^{12}$	$F_{osc}/2^{12} + 512$
0	1	$F_{osc}/2^{15}$	$F_{osc}/2^{15} + 512$
1	0	$F_{osc}/2^{18}$	$F_{osc}/2^{18} + 512$
1	1	$F_{osc}/2^{21}$	$F_{osc}/2^{21} + 512$

T0S0-1&T1S0-1: Timer0 & Timer1 clock source mode select bits. These bits determine the timer0 & timer1 clock source.

T0S1 (T1S1)	T0S0 (T1S0)	Prescale Clock Source
0	0	$F_{osc}/2^2$
0	1	$F_{osc}/2^6$
1	0	$F_{osc}/2^{10}$
1	1	$F_s$

DIVS: Divider clock source control bit 1:

$$DIVS = 0 : F_s/2^{13}$$

$$DIVS = 1 : F_s/2^{14}$$





$\overline{M}/S$ : System clock source control bit:  $\overline{M}/S = 0$  : Fosc = XIN1 ( F<sub>M</sub>)  
 $\overline{M}/S = 1$  : Fosc = XIN2 ( F<sub>s</sub>)

## CLOCK CONTROL2

(initial = 00H)

Bit:	7	6	5	4	3	2	1	0
	ENBUZ	BUZSL	KT1	KT0	-	-	-	-

Mnemonic: CKCON2

Address: 8Fh

ENBUZ: When ENBUZ=1 the BUZ pin works as buzzer output, otherwise BUZ pin is in floating state.

BUZSL: Buzzer output selection. When BUZSL=0 BUZ is the output of octave tone. When BUZZL=1, BUZ is the output of key tone.

KT1-0: Key tone frequency sources from divider. When divider is enable, KT1 and KT0 determines the key tone frequency.

KT1	KT0	Key tone frequency
0	0	Low
0	1	512Hz
1	0	1024Hz
1	1	2048Hz

## PORT 1

(initial=FFH,input mode)

Bit:	7	6	5	4	3	2	1	0
	P1.7	P1.6	P1.5	P1.4	P1.3	P1.2	P1.1	P1.0

Mnemonic: P1

Address: 90h

P1.7-0: P1 can be selected as input or output mode by the P1IO register, at initial reset, P1IO is set to 1, so P1 is used as input mode. When P1IO is set to 0, the P1 is used as CMOS output mode. When P1EF are set and P1IO are set as input mode P1 can be used as external interrupt source. The functions are listed below.

P1.0	: INT2.0	External Interrupt 2
P1.1	: INT2.1	External Interrupt 2
P1.2	: INT2.2	External Interrupt 2
P1.3	: INT2.3	External Interrupt 2
P1.4	: INT3.0	External Interrupt 3
P1.5	: INT3.1	External Interrupt 3
P1.6	: INT3.2	External Interrupt 3
P1.7	: INT3.3	External Interrupt 3



## EXTERNAL INTERRUPT FLAG

(initial = 00H)

Bit:	7	6	5	4	3	2	1	0
	-	-	-	COMPF	DIVF	CIDF	IE3	IE2

Mnemonic: EXIF

Address: 91h

COMPF: Comparator flag. Set by hardware when RESC bit is from low to high.

DIVF: Divider overflow flag.

CIDF: CID interrupt flag. Set by hardware when at least one of CID flags is set.

IE3: External Interrupt 3 flag. Set by hardware when a falling edge is detected on INT3.

IE2: External Interrupt 2 flag. Set by hardware when a falling edge is detected on INT2.

## ROM PAGE POINTER

(initial = 00H)

Bit:	7	6	5	4	3	2	1	0
	-	-	LT1	LT0	-	-	-	PG

Mnemonic: RPAGE

Address: 92h

LT1 and LT0 determine the ROM page of the instruction MOVC reading the content from ROM.

	ROM PAGE	Rom address
(LT1, LT0) = (0, 0)	Page 0	00000H-0FFFFH
(LT1, LT0) = (0, 1)	Page 1	10000H-1FFFFH
(LT1, LT0) = (1, 0)	Page 2	20000H-2FFFFH
(LT1, LT0) = (1, 1)	Page 3	30000H-3FFFFH

PG = 0 indicates the executing program is in page 0, from 00000H-0FFFFH

PG = 1 indicates the executing program is in page 1, from 10000H-1FFFFH

## P1 PINS STATUS

(initial = 00H)

Bit:	7	6	5	4	3	2	1	0
	P1.7SR	P1.6SR	P1.5SR	P1.4SR	P1.3SR	P1.2SR	P1.1SR	P1.0SR

Mnemonic: P1SR

Address: 93h

P1SR: Set when a falling edge is detected on the corresponding P1 pin, clear by software.

## P0 I/O PORT CONTROL

(initial = FFH)

Bit:	7	6	5	4	3	2	1	0
	P0.7IO	P0.6IO	P0.5IO	P0.4IO	P0.3IO	P0.2IO	P0.1IO	P0.0IO

Mnemonic: P0IO

Address: 94h

P0IO: P0 pins I/O control.

1: input mode

0: output mode



## P1 I/O PORT CONTROL

(initial = FFH)

Bit:	7	6	5	4	3	2	1	0
	P1.7IO	P1.6IO	P1.5IO	P1.4IO	P1.3IO	P1.2IO	P1.1IO	P1.0IO

Mnemonic: P1IO

Address: 95h

P1IO: P1 pins I/O control.

1: input mode

0: output mode

## P2 I/O PORT CONTROL

(initial = FFH)

Bit:	7	6	5	4	3	2	1	0
	P2.7IO	P2.6IO	P2.5IO	P2.4IO	P2.3IO	P2.2IO	P2.1IO	P2.0IO

Mnemonic: P2IO

Address: 96h

P2IO: P2 pins I/O control.

1: input mode

0: output mode

## P3 I/O PORT CONTROL

(initial = FFH)

Bit:	7	6	5	4	3	2	1	0
	P3.7IO	P3.6IO	P3.5IO	P3.4IO	P3.3IO	P3.2IO	P3.1IO	P3.0IO

Mnemonic: P3IO

Address: 97h

P3IO: P3 pins I/O control.

1: input mode

0: output mode

## P1 PINS INTERRUPT EABLE

(initial = 00H)

Bit:	7	6	5	4	3	2	1	0
	P1.7EF	P1.6EF	P1.5EF	P1.4EF	P1.3EF	P1.2EF	P1.1EF	P1.0EF

Mnemonic: P1EF

Address: 9Bh

P1EF: P1 pins interrupt function enabled/disabled register

0: disable

1: enable

## P1 PULL-HIGH CONTROL

(initial = 00H)

Bit:	7	6	5	4	3	2	1	0
	P1.7H	P1.6H	P1.5H	P1.4H	P1.3H	P1.2H	P1.1H	P1.0H

Mnemonic: P1H

Address: 9Dh



P1H: Port1 pins pull-high resistor enable/disable

1: enable

0: disable

## P2 PULL-HIGH CONTROL

(initial = 00H)

Bit:	7	6	5	4	3	2	1	0
	P2.7H	P2.6H	P2.5H	P2.4H	P2.3H	P2.2H	P2.1H	P2.0H

Mnemonic: P2H

Address: 9Eh

P2H: Port1 pins pull-high resistor enable/disable

1: enable

0: disable

## P3 PULL-HIGH CONTROL

(initial = 00H)

Bit:	7	6	5	4	3	2	1	0
	P3.7H	P3.6H	P3.5H	P3.4H	P3.3H	P3.2H	P3.1H	P3.0H

Mnemonic: P3H

Address: 9Fh

P3H: Port1 pins pull-high resistor enable/disable

1: enable

0: disable

## PORT 2

(initial = FFH, input mode)

Bit:	7	6	5	4	3	2	1	0
	P2.7	P2.6	P2.5	P2.4	P2.3	P2.2	P2.1	P2.0

Mnemonic: P2

Address: A0h

P2.7-0: Port 2 is an I/O port with internal pull-high resistor. P2 can be selected as input or output mode by the P2IO register. At initial reset, P2 is used as input mode. When P2IO is set to 0, P2 is used as CMOS output mode.

## HIGH BYTE REGISTER

(initial = 00H)

Bit:	7	6	5	4	3	2	1	0
	HB.7	HB.6	HB.5	HB.4	HB.3	HB.2	HB.1	HB.0

Mnemonic: HB

Address: A1h

This register contains the high byte address during execution of "MOVX @Ri," instructions.

## P4 PULL-HIGH CONTROL

(initial = 00H)

Bit:	7	6	5	4	3	2	1	0
	P4.7H	P4.6H	P4.5H	P4.4H	P4.3H	P4.2H	P4.1H	P4.0H

Mnemonic: P4H

Address: A2h



P4H: Port4 pins pull-high resistor enable/disable

1: enable

0: disable

## PORT 4

(initial = FFH,input mode)

Bit:	7	6	5	4	3	2	1	0
	P4.7	P4.6	P4.5	P4.4	P4.3	P4.2	P4.1	P4.0

Mnemonic: P4

Address: A6h

P4.7-0: Port 4 is an I/O port with internal pull-high resistor. P4 can be selected as input or output mode by the P4IO register. At initial reset, P4IO is set to 0FFh, P4 is used as input mode. When P4IO is set to 00h, P4 is used as CMOS output mode. Special function of P4 is described below.

P4.4	VPOS	Positive input of the comparator
P4.2	VNEG	Negative input of the comparator
P4.1	SDATA	Serial port data I/O
P4.0	SCLK	Serial port clock I/O with Smith trigger in input path

## INTERRUPT ENABLE

(initial = 00H)

Bit:	7	6	5	4	3	2	1	0
	EA	ES1	-	-	ET1	EX1	ET0	EX0

Mnemonic: IE

Address: A8h

EA: Global enable. Enable/disable all interrupts.

ES1: Enable Serial port interrupt

ET1: Enable Timer 1 interrupt

EX1: Enable external interrupt 1

ET0: Enable Timer 0 interrupt

EX0: Enable external interrupt 0

## P4 I/O PORT CONTROL

(initial = FFH)

Bit:	7	6	5	4	3	2	1	0
	P4.7IO	P4.6IO	P4.5IO	P4.4IO	P4.3IO	P4.2IO	P4.1IO	P4.0IO

Mnemonic: P4IO

Address: AEh

P4IO: P4 pins I/O control.

1: input mode

0: output mode



## PORT 3

(initial = FFH, input mode)

Bit:	7	6	5	4	3	2	1	0
	P3.7	P3.6	P3.5	P3.4	P3.3	P3.2	P3.1	P3.0

Mnemonic: P3

Address: B0h

P3.7-0: P3 can be selected as input or output mode by the P3IO register, at initial reset, P3IO is set to 0FFH, P3 is used as input mode. When P3IO is set to 00h, the P3 is used as CMOS output mode. Special function of P3 is described below.

P3.5	T1	Timer/Counter 1 external count input
P3.4	T0	Timer/Counter 0 external count input
P3.3	$\overline{INT1}$	External interrupt 1
P3.2	$\overline{INT0}$	External interrupt 0

## CID REGISTER

(initial = 00H, read only)

Bit:	7	6	5	4	3	2	1	0
	-	FCLK	FDATA	FCD	DTMFD	FDR	ALGO	RNG

Mnemonic: CIDR

Address: B1h

This SFR indicates the CID signal immediately. Register data is set or cleared by hardware only.

FCLK: FSK serial clock with the baud rate of 1200Hz.

FDATA: FSK serial bit data.

FCD: Set when FSK carrier is detected. Cleared when FSK carrier is disappeared.

DTMFD: Set when DTMF decoded data is ready. Cleared when DTMF signal ends.

FDR: Set when FSK 8 bits data is ready. Cleared before next FSK start bit comes

ALGO: Dual tone Alert signal Guard time detect signal. Set when a guard time qualified dual tone alert signal has been detected. Cleared when the guard time qualified dual tone alert signal is absent.

RNG: Ring detection bit. High to indicate the detection of line reversal and/or ringing.

## CID FLAG GENERATOR

(initial = 00H)

Bit:	7	6	5	4	3	2	1	0
	-	-	-	FSF	DTMFD F	FDR F	ALGO F	RNG F

Mnemonic: CIDFG

Address: B2h

FSF: Set when FSK Latch clock low to high. Cleared by software

DTMFD F: Set when DTMFD low to high. Cleared by software

FDR F: Set when FDR low to high. Cleared by software.

ALGO F: Set when ALGO low to high. Cleared by software.

RNG F: Set when RNG low to high. Cleared by software.



## CID POWER CONTROL REGISTER (initial = 00H)

Bit:	7	6	5	4	3	2	1	0
	-	-	-	CIDE	-	FSKE	CASE	DTMFE

Mnemonic: CIDPCR

Address: B3h

CIDE: Global enable CID function. Low to disable all functions of CID parts.

FSKE: Enable FSK demodulation circuit.

CASE: Enable Dual Tone Alert Signal detection circuit.

DTMFE: Enable DTMF demodulation circuit.

## FSK DATA REGISTER (initial = XXH)

Bit:	7	6	5	4	3	2	1	0
	FD7	FD6	FD5	FD4	FD3	FD2	FD1	FD0

Mnemonic: FSKDR

Address: B4h

FD7-0: 8 bits FSK demodulated data.

## DTMF DATA REGISTER (initial = XXH)

Bit:	7	6	5	4	3	2	1	0
	CASH	CASL	DTMFH	DTMFL	DD3	DD2	DD1	DD0

Mnemonic: DTMFDR

Address: B5h

CASH: Set when Dual Tone Alert Signal high tone is detected.

CASL: Set when Dual Tone Alert Signal low tone is detected.

DTMFH: Set when DTMF high tone is detected.

DTMFL: Set when DTMF low tone is detected.

DD3-0: 4 bits DTMF demodulated data.

## DTMF PRESENT TIME REGISTER (initial = 19H)

Bit:	7	6	5	4	3	2	1	0
	DPT7	DPT6	DPT5	DPT4	DPT3	DPT2	DPT1	DPT0

Mnemonic: DTMFPT

Address: B6h

The clock period of guard-time timer is 0.8582mS. The default DTMF present time is 21.45mS.

DPT7-0: The pre-set data register for counting DTMF present time. When DTMF is detected(Est, low to high), the guard timer starts to up-count from 00H. As the guard timer is equal to the value of DTMFPT, the exist of the DTMF is accepted. Est changes to low state to stop and reset the counter.



## DTMF ABSENT TIME REGISTER

(initial = 19H)

Bit:	7	6	5	4	3	2	1	0
	DAT7	DAT6	DAT5	DAT4	DAT3	DAT2	DAT1	DAT0

Mnemonic: DTMFAT

Address: B7h

The clock period of guard-time timer is 0.8582mS. The default DTMF absent time is 21.45mS.

DAT7-0: The pre-set data register for counting DTMF absent time. When DTMF is absent(Est, high to low), the guard timer starts to up-count from 00H. As the guard timer is equal to the value of DTMFAT, the finish of DTMF is recognized. Est changes to low state to stop and reset the counter.

## INTERRUPT PRIORITY

(initial = 00H)

Bit:	7	6	5	4	3	2	1	0
	-	PS1	-	-	PT1	PX1	PT0	PX0

Mnemonic: IP

Address: B8h

IP.7: This bit is un-implemented and will read high.

PS1: This bit defines the Serial port interrupt priority. PS1 = 1 sets it to higher priority level

PT1: This bit defines the Timer 1 interrupt priority. PT1 = 1 sets it to higher priority level.

PX1: This bit defines the External interrupt 1 priority. PX1 = 1 sets it to higher priority level.

PT0: This bit defines the Timer 0 interrupt priority. PT0 = 1 sets it to higher priority level.

PX0: This bit defines the External interrupt 0 priority. PX0 = 1 sets it to higher priority level.

## DTMF GENERATOR REGISTER

(initial = 00H)

Bit:	7	6	5	4	3	2	1	0
	-	DTGE	HE	LE	L1	L0	H1	H0

Mnemonic: DTMFG

Address: BAh

L1	L0	H1	H0	Selected tone
x	x	0	0	1209Hz
x	x	0	1	1336Hz
x	x	1	0	1477Hz
x	x	1	1	1633Hz
0	0	x	x	697Hz
0	1	x	x	770Hz
1	0	x	x	852Hz
1	1	x	x	941Hz

LE: Enable low group frequency output.

HE: Enable high group frequency output.

DTGE: Enable dual tone output to DTMF pin.





## COMPARATOR REGISTER

(initial = 00H)

Bit:	7	6	5	4	3	2	1	0
	-	-	-	-	RESC	REF	-	COMPEN

Mnemonic: COMPR

Address: BBh

**RESC:** Result of the comparator. Set when positive analog input voltage is(VPOS or 1.0v internal regular output) higher than negative analog input voltage(VNEG) RESC is a read only bit.

**REF:** REF = 0 reference input from analog input voltage(VPOS/P4.4) pin.  
REF = 1 reference input from the internal regulator output.

**COMPEN:** COMPEN = 0 Disable comparator  
COMPEN = 1 Enable comparator

## IDLE RELEASED CONDITION REGISTER 1

(initial = 00H)

Bit:	7	6	5	4	3	2	1	0
	-	IRCS1	-	-	IRCT1	IRCX1	IRCT0	IRCX0

Mnemonic: IRC1

Address: BCh

One of the bits of IRC1 and IRC2 will be set by hardware to record the idle released condition when the idle mode is released. IRC1 and IRC2 can be set by hardware and can be R/W by software.

**IRCS1:** Idle mode released by Serial port interrupt flag.

**IRCT1:** Idle mode released by Timer 1 interrupt flag.

**IRCX1:** Idle mode released by external interrupt 1 flag.

**IRCT0:** Idle mode released by Timer 0 interrupt flag.

**IRCX0:** Idle mode released by external interrupt 0 flag.

## IDLE RELEASED CONDITION REGISTER 2

(initial = 00H)

Bit:	7	6	5	4	3	2	1	0
	-	-	IRCWDI	IRCCOMP	IRCDIV	IRCCID	IRCX3	IRCX2

Mnemonic: IRC2

Address: BDh

One of the bits of IRC1 and IRC2 will be set by hardware to record the idle released condition when the idle mode is released. IRC1 and IRC2 can be set by hardware and can be R/W by software.

**IRCWDI:** Idle mode released by Watchdog timer interrupt flag.

**IRCCOMP:** Idle mode released by comparator interrupt flag.

**IRCDIV:** Idle mode released by Divider interrupt flag.

**IRCCID:** Idle mode released by CID interrupt flag.

**IRCX3:** Idle mode released by External Interrupt 3 flag.

**IRCX2:** Idle mode released by External Interrupt 2 flag.



## CAS TONE PRESENT TIME REGISTER

(initial = 0FH)

Bit:        7        6        5        4        3        2        1        0

CASPT7	CASPT6	CASPT5	CASPT4	CASPT3	CASPT2	CASPT1	CASPT0
--------	--------	--------	--------	--------	--------	--------	--------

Mnemonic: CASPT

Address: BEh

The clock period of guard-time timer is 0.8582mS. The default alert tone present time is 12.87mS.

CASPT7-0: The pre-set data register for counting CAS tone present time. When CAS tone is detected (ALGR low to high), the guard timer starts to up-count from 00H. As the guard timer is equal to the value of CASPT, the exist of the CAS tone is accepted. ALGR changes to low state to stop and reset the counter.

## CAS TONE ABSENT TIME REGISTER

(initial = 0FH)

Bit:        7        6        5        4        3        2        1        0

CASAT7	CASAT6	CASAT5	CASAT4	CASAT3	CASAT2	CASAT1	CASAT0
--------	--------	--------	--------	--------	--------	--------	--------

Mnemonic: CASAT

Address: BFh

The clock period of guard-time timer is 0.8582mS. The default alert tone absent time is 12.87mS.

CASAT7-0: The pre-set data register for counting CAS tone absent time. When CAS tone is absent (ALGR high to low), the guard timer starts to up-count from 00H. As the guard timer is equal to the value of CASAT, the finish of CAS tone is recognized. ALGR changes to high state to stop and reset the counter.

## SERIAL PORT CONTROL

(initial = 00H)

Bit:        7        6        5        4        3        2        1        0

SF1	-	REGON	REN1	SFQ	SEDG	CLKIO	SIO
-----	---	-------	------	-----	------	-------	-----

Mnemonic: SCON1

Address: C0h

SF1: Serial port interrupt flag. When 8-bits data transited completely, SF1 is set by hardware. SF1 is cleared when serial interrupt routine is executed or cleared by software.

REGON: Regulator on/off control. 0 to disable regulator, 1 to regulator.

REN1: Set REN1 from 0 to 1 to start the serial port to receive 8-bit serial data.

SFQ: SFQ = 0 Serial clock output frequency is equal to  $f_{OSC} / 2$

SFQ = 1 Serial clock output frequency is equal to  $f_{OSC} / 256$

SEDG: SEDG = 0 Serial data latched at falling edge of clock, SCLK = Low initially.

SEDG = 1 Serial data latched at rising edge of clock, SCLK = High initially.

CLKIO: CLKIO = 0 P4.0(SCLK) work as output mode

CLKIO = 1 P4.0(SCLK) work as input mode

SIO: SIO = 0 P4.0 & P4.1 work as normal I/O pin

SIO = 1 P4.0 & P4.1 work as Serial port1 function



## SERIAL DATA BUFFER

(initial = 00H) **Read Only**

Bit:	7	6	5	4	3	2	1	0
	SBUF1.7	SBUF1.6	SBUF1.5	SBUF1.4	SBUF1.3	SBUF1.2	SBUF1.1	SBUF1.0

Mnemonic: SBUF1

Address: C1h

SBUF1.7-0: Serial data on the serial port 1 is read from or written to this location. It actually consists of two separate internal 8-bit registers. One is the receive register, and the other is the transmit buffer. Any read access gets data from the receive data buffer, while write access is to the transmit data buffer.

## REGULATOR VOLTAGE CONTROL REGISTER

(initial = 00H)

Bit:	7	6	5	4	3	2	1	0
	-	-	-	-	REGVC.3	REGVC.2	REGVC.1	REGVC.0

Mnemonic: REGVC

Address: C2h

REGVC.3-0: 4 bits to tune the regulator output voltage.

## POWER MANAGEMENT REGISTER

(initial = XXX00001B)

Bit:	7	6	5	4	3	2	1	0
	XT/RG	RGMD	RGSL	X2OFF	X1OFF	-	-	-

Mnemonic: PMR

Address: C4h

XT/RG: Crystal/RC Oscillator Select. Setting this bit selects crystal or external clock as system clock source. Clearing this bit selects the on-chip RC oscillator as clock source. X1UP (STATUS.4) must be set to 1 and X1OFF (PMR.3) must be cleared before this bit can be set. Attempts to set this bit without obeying these conditions will be ignored.

RGMD: RC Mode Status. This bit indicates the current clock source of micro-controller. When cleared, CPU is operating from the external crystal or oscillator. When set, CPU is operating from the on-chip RC oscillator.

RGSL: RC Oscillator Select. This bit selects the clock source following a resume from Power Down Mode. Setting this bit allows device operating from RC oscillator when a resume from Power Down Mode. When this bit is cleared, the device will hold operation until the crystal oscillator has warmed-up following a resume from Power Down Mode.

X2OFF: Set to disable sub-oscillator (32KHz oscillator)

X1OFF: Crystal Oscillator Disable. Setting this bit disables the external crystal oscillator. This bit can only be set to 1 while the micro-controller is operating from the RC oscillator. Clearing this bit restarts the crystal oscillator, the X1UP (STATUS.4) bit will be set after crystal oscillator warmed-up has completed.

※Please insert at least 5 instructions NOP after X2UP = "1" & Fsys = Fs (CKCON1.0 = "1", M/S).



## STATUS REGISTER

(initial=00H)

Bit:	7	6	5	4	3	2	1	0
	X2UP	HIP	LIP	X1UP	-	-	-	-

Mnemonic: STATUS

Address: C5h

**X2UP:**Sub-crystal oscillator warm-up status. When set, this bit indicates the crystal oscillator has completed the warm-up delay. When X2OFF bit is set, hardware will clear this bit. There are two options which is selected by option code for warm-up delay, one is 1024 clocks warm-up delay, other is 65536 clocks warm-up delay.

**HIP:** High Priority Interrupt Status. When set, it indicates that software is servicing a high priority interrupt. This bit will be cleared when the program executes the corresponding RETI instruction.

**LIP:** Low Priority Interrupt Status. When set, it indicates that software is servicing a low priority interrupt. This bit will be cleared when the program executes the corresponding RETI instruction.

**X1UP:**Crystal Oscillator Warm-up Status. when set, this bit indicates the crystal oscillator has completed the 65536 clocks warm-up delay. Each time the crystal oscillator is restarted by exit from power down mode or the X1OFF bit is set, hardware will clear this bit. This bit is set to 1 after a power-on reset. When this bit is cleared, it prevents software from setting the XT/RG bit to enable CPU operation from crystal oscillator. There are two options which is selected by option code for warm-up delay, one is 4096 clocks warm-up delay, other is 65536 clocks warm-up delay.

## FSK TRANSIMT CONTROL REGISTER

(initial = 00H)

Bit:	7	6	5	4	3	2	1	0
	FTE	FTM	FDS	-	-	-	LO1	LO0

Mnemonic: FSKTC

Address: C6h

**FTE:** FSK transmit Enable; Enable:1, Disable = 0

**FTM:** FSK signal Standard; Bellcore:1, V.23 = 0

**FDS:** FSK data sending status

**LO0, LO1:** FSK transmit level option

FSK Output Level	LO1	LO0
150 mV	0	0
120 mV	0	1
95 mV	1	0
75 mV	1	1

## FSK TRANSMIT DATA BUFFER

(initial = 00H)

Bit:	7	6	5	4	3	2	1	0
	FSKTB.7	FSKTB.6	FSKTB.5	FSKTB.4	FSKTB.3	FSKTB.2	FSKTB.1	FSKTB.0

Mnemonic: FSKTB

Address: C7h

**FSKTB.0:**Only this bit will be latched and send out as FSK signal



## DIVIDER CONTROL

(initial = 01H)

Bit:	7	6	5	4	3	2	1	0
	-	-	-	-	-	-	-	DIVA

Mnemonic: DIVC

Address: C8h

DIVA: Divider available control bit. This bit is set or cleared by software to enable/disable divider. DIVA = 1 to enable the divider. DIVA = 0 to disable the divider. DIVA is reset after reset.

## PROGRAM STATUS WORD

(initial = 00H)

Bit:	7	6	5	4	3	2	1	0
	CY	AC	F0	RS1	RS0	OV	F1	P

Mnemonic: PSW

Address: D0h

CY: Carry flag. Set for an arithmetic operation, which results in a carry being generated from the ALU. It is also used as the accumulator for the bit operations.

AC: Auxiliary carry. Set when the previous operation resulted in a carry from the high order nibble.

F0: User flag 0. General-purpose flag that can be set or cleared by the user.

RS.1-0: Register bank select bits:

RS1	RS0	Register bank	Address
0	0	0	00-07h
0	1	1	08-0Fh
1	0	2	10-17h
1	1	3	18-1Fh

OV: Overflow flag. Set when a carry was generated from the seventh bit but not from the 8th bit as a result of the previous operation, or vice-versa.

F1: User Flag 1. General-purpose flag that can be set or cleared by the user by software.

P: Parity flag. Set/cleared by hardware to indicate odd/even number of 1's in the accumulator.

## WATCHDOG CONTROL

(initial: note)

Bit:	7	6	5	4	3	2	1	0
	-	POR	-	WFS	WDIF	WTRF	EWT	RWT

Mnemonic: WDCON

Address: D8h

POR: Power-on reset flag. Hardware will set this flag when system is powered on and this flag is cleared only by software.

WFS: Watchdog Timer Frequency Select. Set to select  $F_S$  as WDT clock input. Clear to select  $F_{OSC}$  as WDT clock input.

WDIF: Watchdog Timer Interrupt flag. This bit is set whenever the time-out occurs in the watchdog timer. If the Watchdog interrupt is enabled (EIE.5), then an interrupt will occur (if the global interrupt enable is set and other interrupt requirements are met). Software or any reset can clear this bit.



**WTRF:** Watchdog Timer Reset Flag. Hardware will set this bit when the watchdog timer causes a reset. Software can read it but must clear it manually. A power-fail reset will also clear the bit. This bit helps software in determining the cause of a reset. If EWT = 0, the watchdog timer will have no effect on this bit.

**EWT:** Enable Watchdog timer Reset. Setting this bit will enable the Watchdog timer Reset function.

**RWT:** Reset Watchdog Timer. This bit helps in putting the watchdog timer into a known state. It also helps in resetting the watchdog timer before a time-out occurs. Failing to set the EWT before time-out will cause an interrupt, if EWDI (EIE.5) is set, and 512 clocks after that a watchdog timer reset will be generated if EWT is set. This bit is self-clearing by hardware.

**Note:**

The WDCON SFR is set to a 0x000xx0b on an external reset. WTRF is set to a 1 on a Watchdog timer reset, but to a 0 on power on/down resets. WTRF is not altered by an external reset. POR is set to 1 by a power-on reset. EWT is set to 0 on a Power-on reset and unaffected by other resets.

**ACCUMULATOR**

(initial = 00H)

Bit:	7	6	5	4	3	2	1	0
	ACC.7	ACC.6	ACC.5	ACC.4	ACC.3	ACC.2	ACC.1	ACC.0

Mnemonic: ACC

Address: E0h

ACC.7-0: The ACC register.

**EXTENDED INTERRUPT ENABLE**

(initial = 00H)

Bit:	7	6	5	4	3	2	1	0
	-	-	EWDI	ECOMP	EDIV	ECID	EX3	EX2

Mnemonic: EIE

Address: E8h

EIE.7-6: Reserved bits.

EWDI: Enable Watchdog timer interrupt.

ECOMP: Enable comparator interrupt.

EDIV: Enable Divider interrupt.

ECID: Enable CID interrupt.

EX3: External Interrupt 3 Enable.

EX2: External Interrupt 2 Enable.

**B REGISTER**

(initial = 00H)

Bit:	7	6	5	4	3	2	1	0
	B.7	B.6	B.5	B.4	B.3	B.2	B.1	B.0

Mnemonic: B

Address: F0h

B.7-0: The B register serves as a second accumulator.



## EXTENDED INTERRUPT PRIORITY

(initial = 00H)

Bit:	7	6	5	4	3	2	1	0
	-	-	PWDI	PCOMP	PDIV	PCID	PX3	PX2

Mnemonic: EIP

Address: F8h

PWDI: Watchdog timer interrupt priority. 0 = Low priority, 1 = High priority.

PCOMP: Comparator interrupt priority. 0 = Low priority, 1 = High priority.

PDIV: Divider Interrupt Priority. 0 = Low priority, 1 = High priority.

PCID: CID Interrupt Priority. 0 = Low priority, 1 = High priority.

PX3: External Interrupt 3 Priority. 0 = Low priority, 1 = High priority.

PX2: External Interrupt 2 Priority. 0 = Low priority, 1 = High priority.

## CID GAIN CONTROL DATA

(initial = 00H)

Bit:	7	6	5	4	3	2	1	0
	BIT7	BIT6	BIT5	BIT4	BIT3	BIT2	BIT1	BIT0

Mnemonic: CIDGD

Address: F9h

CIDGD.7-0: The data value of programmable CID input filter gain and hysteresis.

## CID GAIN CONTROL ADDRESS

(initial = 00H)

Bit:	7	6	5	4	3	2	1	0
	-	-	-	-	BIT3	BIT2	BIT1	BIT0

Mnemonic: CIDGA

Address: FAh

CIDGA.3: The CIDGD latch control signal. Rising high pulse to latch CIDGD into CID gain control register.

CIDGA.2-0: The address to indicate CID input gain control registers.



### 6.3 Initial State of Registers

The following table lists the initial state of registers after different reset functions.

SFR ITEM	RESET INITIAL VALUE	POR	WDT RESET
ACC, B, STATUS, PSW,	00h	00h	00h
SP,	07h	07h	07h
PAGE	00h	00h	00h
P0, P1, P2, P3, P4, P0IO, P1IO, P2IO, P3IO, P4IO	ffh	ffh	ffh
DPL, DPH, DPL1, DPH1, DPS	00h	00h	00h
PCON, TCON, TMOD,	00h	00h	00h
TL0, TL1, TH0, TH1,	00h	00h	00h
CKCON1, CKCON2, SCON1, SBUF1, REGVC,	00h	00h	00h
EXIF, IE, HB, IP, EIE, EIP	00h	00h	00h
P1SR, P1EF, P1H, P2H, P3H, P4H,	00h	00h	00h
CIDR, CIDFG, CIDPCR, CIDGD, CIDGA,	00h	00h	00h
FSKDR, DTMFDR,	***** B	***** B	***** B
DTMFPT, DTMFAT,	19h	19h	19h
DTMFG, COMPR, IRC1, IRC2, FSKTC, FSKTB,	00h	00h	00h
CASPT, CASAT,	0fh	0fh	0fh
PMR	1000xx1B	1000xx1B	uuu00xx1B
DIVC,	01h	01h	01h
WDCON	0u000uu0B	01000000B	0u0001u0B

**Notes:**

x: Un-used

u: unchanged

\*: Depend on circuit detection





## 6.4 Instruction

The W925E/C240 executes all the instructions of the standard 8032 family. However, timing of these instructions is different. In the W925E/C240, each machine cycle consists of 4 clock periods, while in the standard 8032 it consists of 12 clock periods. Also, in the W925E/C240 there is only one fetch per machine cycle i.e. 4 clocks per fetch, while in the standard 8032 there can be two fetches per machine cycle, which works out to 6 clocks per fetch.

**Table 2 Instructions that affect Flag settings**

INSTRUCTION	CARRY	OVERFLOW	AUXILIARY CARRY	INSTRUCTION	CARRY	OVERFLOW	AUXILIARY CARRY
INC, DEC	-	-	-	SETB C	1		
ADD	X	X	X	CLR C	0		
ADDC	X	X	X	CPL C	X		
SUBB	X	X	X	ANL C, bit	X		
MUL	0	X		ANL C, bit	X		
DIV	0	X		ORL C, bit	X		
DA A	X			ORL C, bit	X		
RRC A	X			MOV C, bit	X		
RLC A	X			CJNE	X		

A "X" indicates that the modification is as per the result of instruction.

A "-" indicates that the flag is not effected by the instruction.

**Table 3 Instruction Timing for W925E/C240**

INSTRUCTION	HEX OP-CODE	BYTES	MACHINE CYCLES	INSTRUCTION	HEX OP-CODE	BYTES	MACHINE CYCLES
NOP	00	1	1	ANL A, R0	58	1	1
ADD A, R0	28	1	1	ANL A, R1	59	1	1
ADD A, R1	29	1	1	ANL A, R2	5A	1	1
ADD A, R2	2A	1	1	ANL A, R3	5B	1	1
ADD A, R3	2B	1	1	ANL A, R4	5C	1	1
ADD A, R4	2C	1	1	ANL A, R5	5D	1	1
ADD A, R5	2D	1	1	ANL A, R6	5E	1	1
ADD A, R6	2E	1	1	ANL A, R7	5F	1	1
ADD A, R7	2F	1	1	ANL A, @R0	56	1	1
ADD A, @R0	26	1	1	ANL A, @R1	57	1	1
ADD A, @R1	27	1	1	ANL A, direct	55	2	2
ADD A, direct	25	2	2	ANL A, #data	54	2	2
ADD A, #data	24	2	2	ANL direct, A	52	2	2
ADDC A, R0	38	1	1	ANL direct, #data	53	3	3
ADDC A, R1	39	1	1	ANL C, bit	82	2	2



Table 3. Instruction Timing for W925E/C240, continued

INSTRUCTION	HEX OP-CODE	BYTES	MACHINE CYCLES	INSTRUCTION	HEX OP-CODE	BYTES	MACHINE CYCLES
ADDC A, R2	3A	1	1	ANL C, /bit	B0	2	2
ADDC A, R3	3B	1	1	CJNE A, direct, rel	B5	3	4
ADDC A, R4	3C	1	1	CJNE A, #data, rel	B4	3	4
ADDC A, R5	3D	1	1	CJNE @R0, #data, rel	B6	3	4
ADDC A, R6	3E	1	1	CJNE @R1, #data, rel	B7	3	4
ADDC A, R7	3F	1	1	CJNE R0, #data, rel	B8	3	4
ADDC A, @R0	36	1	1	CJNE R1, #data, rel	B9	3	4
ADDC A, @R1	37	1	1	CJNE R2, #data, rel	BA	3	4
ADDC A, direct	35	2	2	CJNE R3, #data, rel	BB	3	4
ADDC A, #data	34	2	2	CJNE R4, #data, rel	BC	3	4
ACALL addr11	71, 91, B1, 11, 31, 51, D1, F1	2	3	CJNE R5, #data, rel	BD	3	4
AJMP ADDR11	01, 21, 41, 61, 81, A1, C1, E1	2	3	CJNE R6, #data, rel	BE	3	4
CJNE R7, #data, rel	BF	3	4	JC rel	40	2	3
CLR A	E4	1	1	JNC rel	50	2	3
CPL A	F4	1	1	JB bit, rel	20	3	4
CLR C	C3	1	1	JNB bit, rel	30	3	4
CLR bit	C2	2	2	JBC bit, rel	10	3	4
CPL C	B3	1	1	LCALL addr16	12	3	4
CPL bit	B2	2	2	LJMP addr16	02	3	4
DEC A	14	1	1	MUL AB	A4	1	5
DEC R0	18	1	1	MOV A, R0	E8	1	1
DEC R1	19	1	1	MOV A, R1	E9	1	1
DEC R2	1A	1	1	MOV A, R2	EA	1	1
DEC R3	1B	1	1	MOV A, R3	EB	1	1
DEC R4	1C	1	1	MOV A, R4	EC	1	1
DEC R5	1D	1	1	MOV A, R5	ED	1	1
DEC R6	1E	1	1	MOV A, R6	EE	1	1
DEC R7	1F	1	1	MOV A, R7	EF	1	1
DEC @R0	16	1	1	MOV A, @R0	E6	1	1
DEC @R1	17	1	1	MOV A, @R1	E7	1	1
DEC direct	15	2	2	MOV A, direct	E5	2	2
DEC DPTR	A5	1	2	MOV A, #data	74	2	2
DIV AB	84	1	5	MOV R0, A	F8	1	1
DA A	D4	1	1	MOV R1, A	F9	1	1



Table 3. Instruction Timing for W925E/C240, continued

INSTRUCTION	HEX OP-CODE	BYTES	MACHINE CYCLES	INSTRUCTION	HEX OP-CODE	BYTES	MACHINE CYCLES
DJNZ R0, rel	D8	2	3	MOV R2, A	FA	1	1
DJNZ R1, rel	D9	2	3	MOV R3, A	FB	1	1
DJNZ R2, rel	DA	2	3	MOV R4, A	FC	1	1
DJNZ R3, rel	DB	2	3	MOV R5, A	FD	1	1
DJNZ R4, rel	DC	2	3	MOV R6, A	FE	1	1
DJNZ R5, rel	DD	2	3	MOV R7, A	FF	1	1
DJNZ R6, rel	DE	2	3	MOV R0, direct	A8	2	2
DJNZ R7, rel	DF	2	3	MOV R1, direct	A9	2	2
DJNZ direct, rel	D5	3	4	MOV R2, direct	AA	2	2
INC A	04	1	1	MOV R3, direct	AB	2	2
INC R0	08	1	1	MOV R4, direct	AC	2	2
INC R1	09	1	1	MOV R5, direct	AD	2	2
INC R2	0A	1	1	MOV R6, direct	AE	2	2
INC R3	0B	1	1	MOV R7, direct	AF	2	2
INC R4	0C	1	1	MOV R0, #data	78	2	2
INC R5	0D	1	1	MOV R1, #data	79	2	2
INC R6	0E	1	1	MOV R2, #data	7A	2	2
INC R7	0F	1	1	MOV R3, #data	7B	2	2
INC @R0	06	1	1	MOV R4, #data	7C	2	2
INC @R1	07	1	1	MOV R5, #data	7D	2	2
INC direct	05	2	2	MOV R6, #data	7E	2	2
INC DPTR	A3	1	2	MOV R7, #data	7F	2	2
JMP @A+DPTR	73	1	2	MOV @R0, A	F6	1	1
JZ rel	60	2	3	MOV @R1, A	F7	1	1
JNZ rel	70	2	3	MOV @R0, direct	A6	2	2
MOV @R1, direct	A7	2	2	RL A	23	1	1
MOV @R0, #data	76	2	2	RLC A	33	1	1
MOV @R1, #data	77	2	2	RR A	03	1	1
MOV direct, A	F5	2	2	RRC A	13	1	1
MOV direct, R0	88	2	2	SETB C	D3	1	1
MOV direct, R1	89	2	2	SETB bit	D2	2	2
MOV direct, R2	8A	2	2	SWAP A	C4	1	1
MOV direct, R3	8B	2	2	SJMP rel	80	2	3
MOV direct, R4	8C	2	2	SUBB A, R0	98	1	1
MOV direct, R5	8D	2	2	SUBB A, R1	99	1	1
MOV direct, R6	8E	2	2	SUBB A, R2	9A	1	1
MOV direct, R7	8F	2	2	SUBB A, R3	9B	1	1
MOV direct, @R0	86	2	2	SUBB A, R4	9C	1	1
MOV direct, @R1	87	2	2	SUBB A, R5	9D	1	1



Table 3. Instruction Timing for W925E/C240, continued

INSTRUCTION	HEX OP-CODE	BYTES	MACHINE CYCLES	INSTRUCTION	HEX OP-CODE	BYTES	MACHINE CYCLES
MOV direct, direct	85	3	3	SUBB A, R6	9E	1	1
MOV direct, #data	75	3	3	SUBB A, R7	9F	1	1
MOV DPTR, #data 16	90	3	3	SUBB A, @R0	96	1	1
MOVC A, @A+DPTR	93	1	2	SUBB A, @R1	97	1	1
MOVC A, @A+PC	83	1	2	SUBB A, direct	95	2	2
MOVX A, @R0	E2	1	2	SUBB A, #data	94	2	2
MOVX A, @R1	E3	1	2	XCH A, R0	C8	1	1
MOVX A, @DPTR	E0	1	2	XCH A, R1	C9	1	1
MOVX @R0, A	F2	1	2	XCH A, R2	CA	1	1
MOVX @R1, A	F3	1	2	XCH A, R3	CB	1	1
MOVX @DPTR, A	F0	1	2	XCH A, R4	CC	1	1
MOV C, bit	A2	2	2	XCH A, R5	CD	1	1
MOV bit, C	92	2	2	XCH A, R6	CE	1	1
ORL A, R0	48	1	1	XCH A, R7	CF	1	1
ORL A, R1	49	1	1	XCH A, @R0	C6	1	1
ORL A, R2	4A	1	1	XCH A, @R1	C7	1	1
ORL A, R3	4B	1	1	XCHD A, @R0	D6	1	1
ORL A, R4	4C	1	1	XCHD A, @R1	D7	1	1
ORL A, R5	4D	1	1	XCH A, direct	C5	2	2
ORL A, R6	4E	1	1	XRL A, R0	68	1	1
ORL A, R7	4F	1	1	XRL A, R1	69	1	1
ORL A, @R0	46	1	1	XRL A, R2	6A	1	1
ORL A, @R1	47	1	1	XRL A, R3	6B	1	1
ORL A, direct	45	2	2	XRL A, R4	6C	1	1
ORL A, #data	44	2	2	XRL A, R5	6D	1	1
ORL direct, A	42	2	2	XRL A, R6	6E	1	1
ORL direct, #data	43	3	3	XRL A, R7	6F	1	1
ORL C, bit	72	2	2	XRL A, @R0	66	1	1
ORL C, /bit	A0	2	2	XRL A, @R1	67	1	1
PUSH direct	C0	2	2	XRL A, direct	65	2	2
POP direct	D0	2	2	XRL A, #data	64	2	2
RET	22	1	2	XRL direct, A	62	2	2
RETI	32	1	2	XRL direct, #data	63	3	3



## 6.5 Power Management

The W925E/C240 has 3 operation mode, normal mode, idle mode and power down mode to manage the power consumption.

### Normal Mode

Normal mode is used in the normal operation status. All functions can be worked in the normal mode.

### Idle Mode

The user can put the device into idle mode by writing 1 to the bit PCON.0. The instruction that sets the idle bit is the last instruction that will be executed before the device goes into Idle Mode. In the Idle mode, the clock to the CPU is halted, but not to the Interrupt, Timer, Watchdog timer, Divider, Comparator and CID blocks. This forces the CPU state to be frozen; the Program counter, the Stack Pointer, the Program Status Word, the Accumulator and the other registers hold their contents. The port pins hold the logical states they had at the time Idle was activated. The Idle mode can be terminated in two ways. Since the interrupt controller is still active, the activation of any enabled interrupt can wake up the processor. This will automatically terminate the Idle mode and clear the Idle bit. And if bit IDLT(PCON.4) is cleared the Interrupt Service Routine(ISR) will be executed, else the idle mode is released directly without any execution of ISR. After the ISR, execution of the program will continue from the instruction, which put the device into Idle mode.

The Idle mode can also be exited by activating the reset. The device can be put into reset either by applying a low on the external RESET pin or a power on/fail reset condition or a Watchdog timer reset. The external reset pin has to be held low for at least two machine cycles i.e. 8 clock periods to be recognized as a valid reset. In the reset, condition the program counter is reset to 0000h and all the SFRs are set to the reset condition. Since the clock is still running in the period of external reset therefore the instruction is executed immediately. In the Idle mode, the Watchdog timer continues to run, and if enabled, a time-out will cause a watchdog timer interrupt, which will wake up the device. The software must reset the Watchdog timer in order to preempt the reset, which will occur after 512 clock periods of the time-out.

### Power Down Mode

The device can be put into Power Down mode by writing 1 to bit PCON.1. The instruction that does this will be the last instruction to be executed before the device goes into Power Down mode. In the Power Down mode, all the clocks are stopped and the device comes to a halt. All activity is completely stopped and the power consumption is reduced to the lowest possible value. The port pins output the values held by their respective SFRs.

The W925E/C240 will exit the Power Down mode by reset or external interrupts or ring detected. An external reset can be used to exit the Power down state. The low on RESET pin terminates the Power Down mode, and restarts the clock. The on-chip hardware will now provide a delay of 65536 clock, which is used to provide time for the oscillator to restart and stabilize. Once this delay is complete, an internal reset is activated and the program execution will restart from 0000h. In the Power down mode, the clock is stopped, so the Watchdog timer cannot be used to provide the reset to exit Power down mode.

The W925E/C240 can be woken from the Power Down mode by forcing an external interrupt pin activated and ring detected, provided the corresponding interrupt is enabled, while the global enable(EA) bit is set. While the power down is released, the device will experience a warm-up delay of 65536 clock cycles to ensure the stabilization of oscillation. Then device executes the interrupt service routine for the corresponding external interrupt or CID interrupt. After the interrupt service routine is completed, the program returns to the instruction after the one, which put the device into Power Down



mode and continues from there. When RGSL (PMR.5) bit is set to 1, the CPU will use the internal RC oscillator instead of crystal to exit Power Down mode. The micro-controller will automatically switch from RC oscillator to crystal after a warm-up delay of 65536 crystal clocks. The RC oscillator runs at approximately 2–4 MHz. Using RC oscillator to exit from Power Down mode saves the time for waiting crystal start-up. It is useful in the low power system which usually be awakened from a short operation then returns to Power Down mode.

## 6.6 Reset

The user has several hardware related options for placing the W925E/C240 into reset condition. In general, most register bits go to their reset value irrespective of the reset condition, but there are few flags that initial states are dependant on the source of reset. User can recognize the cause of reset by reading the flags. There are three ways of putting the device into reset state. They are External reset, Power on reset and Watchdog reset.

### External Reset

The device continuously samples the RESET pin at state C4 of every machine cycle. Therefore, the RESET pin must be held for at least 2 machine cycles to ensure detection of a valid RESET low. The reset circuitry then synchronously applies the internal reset signal. Thus, the reset is a synchronous operation and requires the clock to be running to cause an external reset.

Once the device is in reset condition, it will remain so as long as RESET is 0. Even after RESET is deactivated, the device will continue to be in reset state for up to two machine cycles, and then begin program execution from 0000h. There is no flag associated with the external reset condition. However, since some flags indicate the cause of other two reset, the external reset can be considered as the default reset if those two flags are cleared.

### Watchdog Timer Reset

The Watchdog timer is a free running timer with programmable time-out intervals. The user can reset the watchdog timer at any time to avoid producing the flag WDIF. If the Watchdog reset is enabled and the flag WDIF is set high, the watchdog timer reset is performed after the additional 512 clocks come. This places the device into the reset condition. The reset condition is maintained by hardware for two machine cycles. Once the reset is removed, the device will begin execution from 0000h.

## 6.7 Interrupt

The W925E/C240 has a two priority levels interrupt structure with 11 interrupt sources. Each of the interrupt sources has an individual priority bit, flag, interrupt vector and enable bit. In addition, the interrupts can be globally enabled or disabled.

### Interrupt Sources

The External Interrupts  $\overline{\text{INT0}}$  and  $\overline{\text{INT1}}$  can be either edge triggered or level triggered, depending on bits IT0 and IT1. The bits IE0 and IE1 in the TCON register are the flags, which are checked to generate the interrupt. In the edge triggered mode of the  $\overline{\text{INT0}}$  and the  $\overline{\text{INT1}}$  inputs are sampled in every machine cycle. If the sample is high in one cycle and low in the next, then a high to low transition is detected and the interrupts request flag IEx in TCON is set. The flag bit requests the interrupt. Since the external interrupts are sampled every machine cycle, they have to be held high or low for at least one complete machine cycle. The IEx flag is automatically cleared when the service routine is called. If the level triggered mode is selected, then the requesting source has to hold the pin low until the interrupt is serviced. The IEx flag will not be cleared by the hardware on entering the



service routine. If the interrupt continues to be held low even after the service routine is completed, then the processor may acknowledge another interrupt request from the same source. Note that the external interrupts INT2 to INT3 are edge triggered only.

The TF0, TF1 flags generate the Timer 0, 1 Interrupts. These flags are set by the overflow in the Timer 0, Timer 1. The TF0 and TF1 flags are automatically cleared by the hardware when the timer interrupt is serviced.

The Watchdog timer can be used as a system monitor or a simple timer. In either case, when the time-out count is reached, the Watchdog timer interrupt flag WDIF (WDCON.3) is set. If the enable bit EIE.5 enables the interrupt, then an interrupt will occur.

The Serial block can generate interrupts on reception or transmission. There are one interrupt sources from the Serial block, which are obtained by SF1 in the SCON1. SF1 is cleared automatically when the serial port interrupt is serviced.

The divider interrupt is generated by DIVF that is set when divider overflows. DIVF is set by hardware and cleared when divider interrupt is serviced. The divider interrupt is enable/disable if the bit EDIV is high/low.

The comparator interrupt is produced by COMPF, which is set when the RESC bit is changed from low to high. RESC, which is the real-time result of comparator, set when the voltage of reference input is higher than the voltage of analog input.

The CID interrupt is generated by CIDF. The CIDF is a logic OR output of all CID flags which are set by hardware and cleared by software. The structure of the CID flags is shown in Figure 6-4.

Each of the individual interrupts can be enabled or disabled by setting or clearing the corresponding bits in the IE and EIE SFR. A bit EA, which is located in IE.7, is a global control bit to enable/disable the all interrupt. When bit EA is zero all interrupts are disabling and when bit EA is high, each interrupt is enable individually by the corresponding bit.

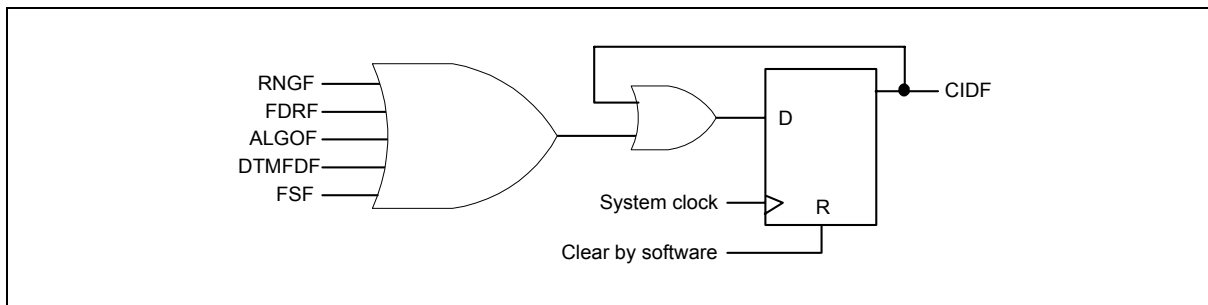

Figure 6-4 The Structure of CID Flags

### Priority Level Structure

There are two priority levels for the interrupts, high and low. The interrupt sources can be individually set to either high or low levels. Naturally, a higher priority interrupt cannot be interrupted by a lower priority interrupt. However there exists a pre-defined hierarchy amongst the interrupts themselves. This hierarchy comes into play when the interrupt controller has to resolve simultaneous requests having the same priority level. This hierarchy is defined as shown below; the interrupts are numbered starting from the highest priority to the lowest.

Table 4 Interrupt table.

INTERRUPT	FLAG NAME	FLAG LOCATION	EN BIT	EN BIT LOCATION	PRIORITY	FLAG CLEARED BY	INTERRUPT VECTOR
External interrupt 0	IE0	TCON.1	EX0	IE.0	1 (highest)	hardware + software	03h
Timer0 overflow	TF0	TCON.5	ET0	IE.1	2	hardware + software	0Bh
External interrupt 1	IE1	TCON.3	EX1	IE.2	3	hardware + software	13h
Timer1 overflow	TF1	TCON.7	ET1	IE.3	4	hardware + software	1Bh
Serial port	SF1	SCON1.7	ES1	IE.6	5	hardware + software	3Bh
External interrupt 2	<i>IE2</i>	EXIF.0	EX2	EIE.0	6	hardware + software	43h
External interrupt 3	<i>IE3</i>	EXIF.1	EX3	EIE.1	7	hardware + software	4Bh
CID	<i>CIDF</i>	EXIF.2	ECID	EIE.2	8	software	53h
Divider overflow	<i>DIVF</i>	EXIF.3	EDIV	EIE.3	9	hardware + software	5Bh
Compare difference	<i>COMPF</i>	EXIF.4	ECOMP	EIE.4	10	hardware + software	63h
Watchdog timer	<i>WDIF</i>	WDCON.3	EWDI	EIE.5	11 (lowest)	software	6Bh

**Ps:** The flags marked as the italic font are not bit-addressable.

The interrupt flags are sampled every machine cycle. In the same machine cycle, the sampled interrupts are polled and their priority is resolved. If certain conditions are met then the hardware will execute an internally generated LCALL instruction which will vector the process to the appropriate interrupt vector address. The conditions for generating the LCALL are

1. An interrupt of equal or higher priority is not currently being serviced.
2. The current polling cycle is the last machine cycle of the instruction currently being executed.
3. The current instruction does not involve a write to IP, IE, EIP or EIE registers and is not a RETI.

If any of these conditions is not met, then the LCALL will not be generated. The polling cycle is repeated every machine cycle, with the interrupts being sampled in the same machine cycle. If an interrupt flag is active in one cycle but not responded to, and is not active when the above conditions are met, the denied interrupt will not be serviced. This means that active interrupts are not remembered. Note that every polling cycle is new.

Execution continues from the vectored address until an RETI instruction is executed. On execution of the RETI instruction, the processor pops out the top content of Stack to the PC. The processor is not notified anything if the content of stack was changed. Note that a RET instruction would perform exactly the same process as a RETI instruction, but it would not inform the Interrupt Controller that the interrupt service routine is completed, and would leave the controller still thinking that the service routine is underway.





### 6.8 Programmable Timers/Counters

The W925E/C240 has 2 16-bit timer/counters. There are two 8-bit registers to perform a 16-bit counting register in every timer/counter. In timer/counter 0, TH0 is the upper 8 bits register and TL0 is the lower 8 bits register. Similarly, timer/counter 1 have two 8-bit registers, TH1 and TL1. Each timer/counter has 4 kind of clock sources which are  $F_{osc}/4$ ,  $F_{osc}/64$ ,  $F_{osc}/1024$  and  $F_s$ . There are 3 operating modes in each timer/counter 0 and 1. The operating modes of timer/ counter0 is identical to timer/counter1. The overflow signal of each timer/counter is sampled at phase 2 in every system machine cycle, therefore when the system clock and the timer/counter clock both are from sub-oscillator, if the overflow frequency is higher than  $F_s/4$  the overflow flag cannot be sampled correctly. Only one overflow flag can be sampled in a machine cycle others will be missed.

#### MODE 0

In Mode 0, the timer/counters act as 13-bit timer/counters. The 13 bits consist of 8 bits of THx and lower 5 bits of TLx. The upper 3 bits of TLx are ignored.

The negative edge of the clock causes the content of the TLx register to increase one. When the fifth bit in TLx moves from 1 to 0, then the count in the THx register is incremented. When the count in THx moves from FFh to 00h, then the overflow flag TFX is set. The counted input is enabled only if TRx is set and either  $GATE=0$  or  $\overline{INTx}=1$ . When  $C/\overline{T}$  is set to 0, then it will count clock cycles, and if  $C/\overline{T}$  is set to 1, then it will count 1 to 0 transitions on T0 (P3.4) for timer 0 and T1 (P3.5) for timer 1. When the 13-bit count reaches 1FFFh, the next count will cause it to rollover to 0000h. The timer overflow flag TFX of the relevant timer is set and if enabled an interrupts will occur. Note that when they are used as a timer, the bits of the CKCON1 select the time-base.

#### MODE1

Mode 1 is similar to Mode 0 except that the counting register forms a 16-bit counter, rather than a 13 bit counter.

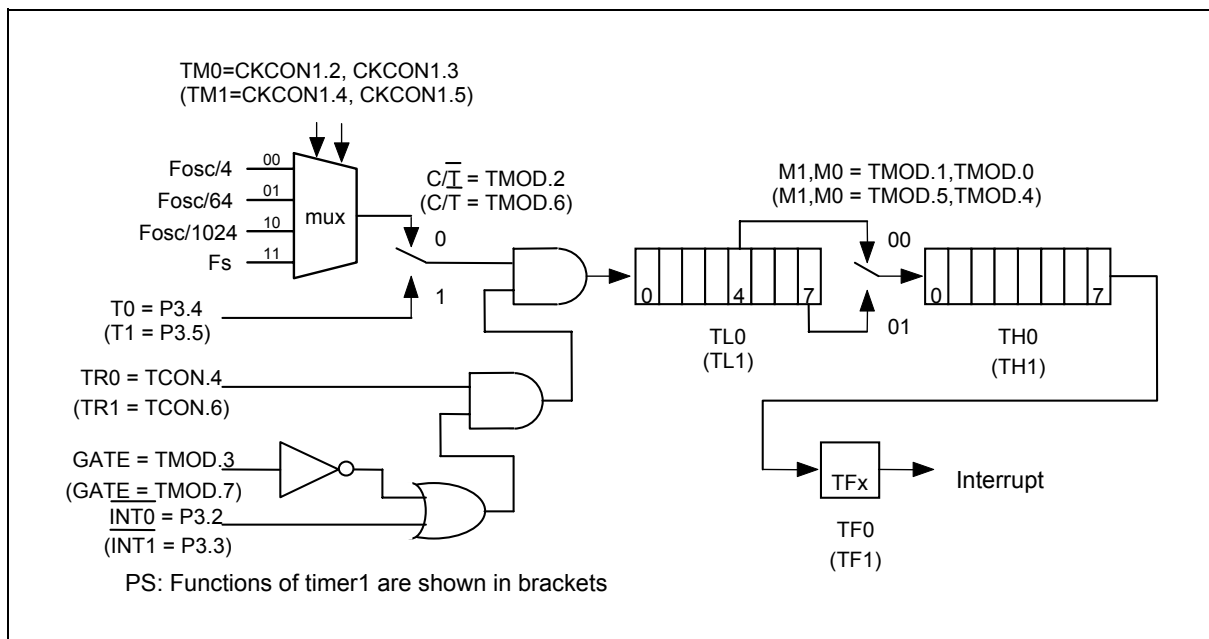

Figure 6-5 Mode 0 & Mode 1 of Timer/Counter 0 & 1



**MODE 2**

Mode 2 is the Auto Reload Mode. In mode 2, TLx acts as an 8-bit count register, while THx holds the reload value. When the TLx register overflows from FFh to 00h, the TFx bit is set and TLx is reloaded with the content of THx, and the counting process continues from the reloaded TLx. The reload operation leaves the content of the THx register unchanged. Counting is controlled by the TRx bit and the proper setting of GATE and  $\overline{\text{INTx}}$  pins.

**BUZZER**

In mode 2, timer 0 can be use to output an arbitrary frequency to the BUZ pin by programming bit6 and bit7 of CKCON2. BUZ pin can be configured as key tone (KT) output by setting BUZSL to high. When disable buzzer output by clearing ENBUZ to low, the BUZ output is in floating status.

In the case where timer 0 clock input is FT, the desired frequency for BUZ output =  $FT / (255 - \text{preset value} + 1) / 2$  (HZ).

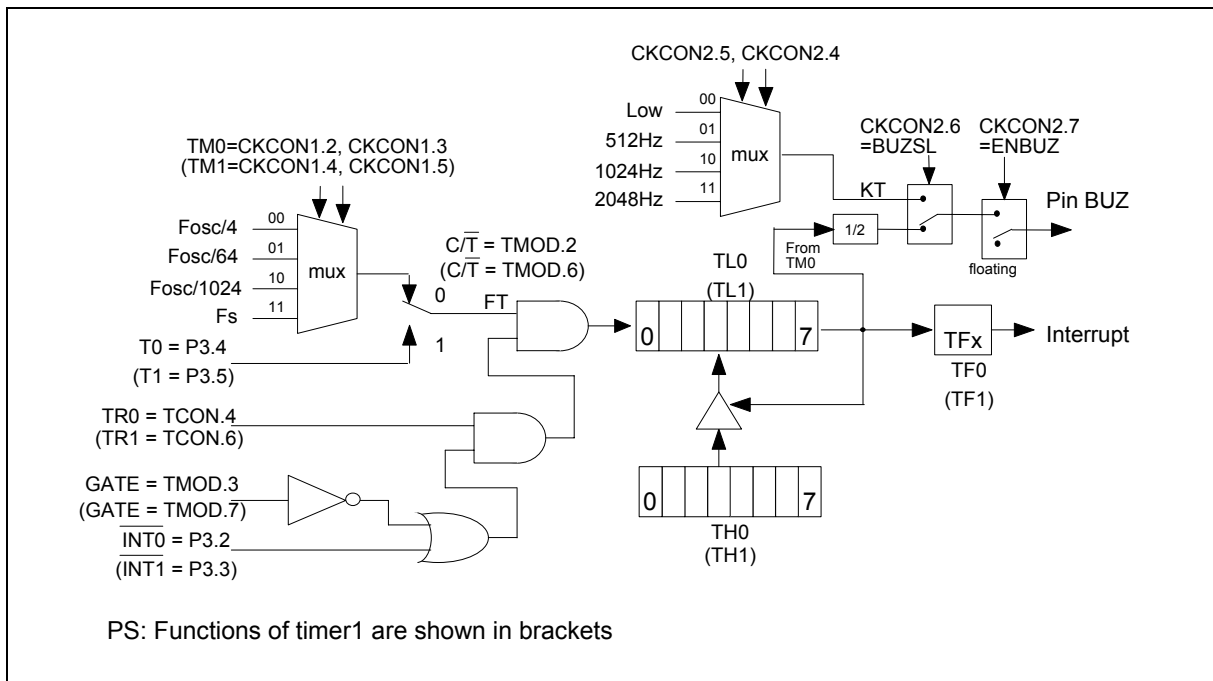

Figure 6-6 Mode 2 of Timer/Counter 0 & 1

When FT equals 32768 Hz, depending on the preset value of TM0, the BUZ pin will output a single tone signal in the tone frequency range from 64 Hz to 16384 Hz. The relation between the tone frequency and the preset value of TM0 is shown in the table below.



**Table 5 The relation between the tone frequency and the preset value of TM0**

		3rd octave			4th octave			5th octave		
		Tone frequency	TM0 preset value & BUZ frequency		Tone frequency	TM0 preset value & BUZ frequency		Tone frequency	TM0 preset value & BUZ frequency	
<b>T O N E</b>	<b>C</b>	130.81	83H	131.07	261.63	C1H	260.06	523.25	E1H	528.51
	<b>C #</b>	138.59	8AH	138.84	277.18	C5H	277.69	554.37	E3H	564.96
	<b>D</b>	146.83	90H	146.28	293.66	C8H	292.57	587.33	E4H	585.14
	<b>D #</b>	155.56	97H	156.03	311.13	CBH	309.13	622.25	E6H	630.15
	<b>E</b>	164.81	9DH	165.49	329.63	CEH	327.68	659.26	E7H	655.36
	<b>F</b>	174.61	A2H	174.30	349.23	D1H	348.58	698.46	E9H	712.34
	<b>F #</b>	185.00	A7H	184.09	369.99	D4H	372.35	739.99	EAH	744.72
	<b>G</b>	196.00	ACH	195.04	392.00	D6H	390.08	783.99	EBH	780.19
	<b>G #</b>	207.65	B1H	207.39	415.30	D9H	420.10	830.61	ECH	819.20
	<b>A</b>	220.00	B6H	221.40	<b>440.00</b>	<b>DBH</b>	<b>442.81</b>	880.00	EDH	862.84
	<b>A #</b>	233.08	BAH	234.05	466.16	DDH	468.11	932.23	EEH	910.22
	<b>B</b>	246.94	BEH	248.24	493.88	DF	496.48	987.77	EFH	963.76

**Note:** Central tone is DB (440 Hz).

**WATCHDOG TIMER**

The Watchdog timer is a free-running timer that can be programmed by the user to serve as a system monitor, a time-base generator or an event timer. It is a set of dividers that divides the system clock. The divider output is selectable and determines the time-out interval. In the condition of the timer-out expiring, the WDT interrupt and WDT reset may be executed if the corresponding enables control bits are set. The interrupt will occur if the individual interrupt enable and the global enable are set. The interrupt and reset functions are independent of each other and may be used separately or together depending on the users software.

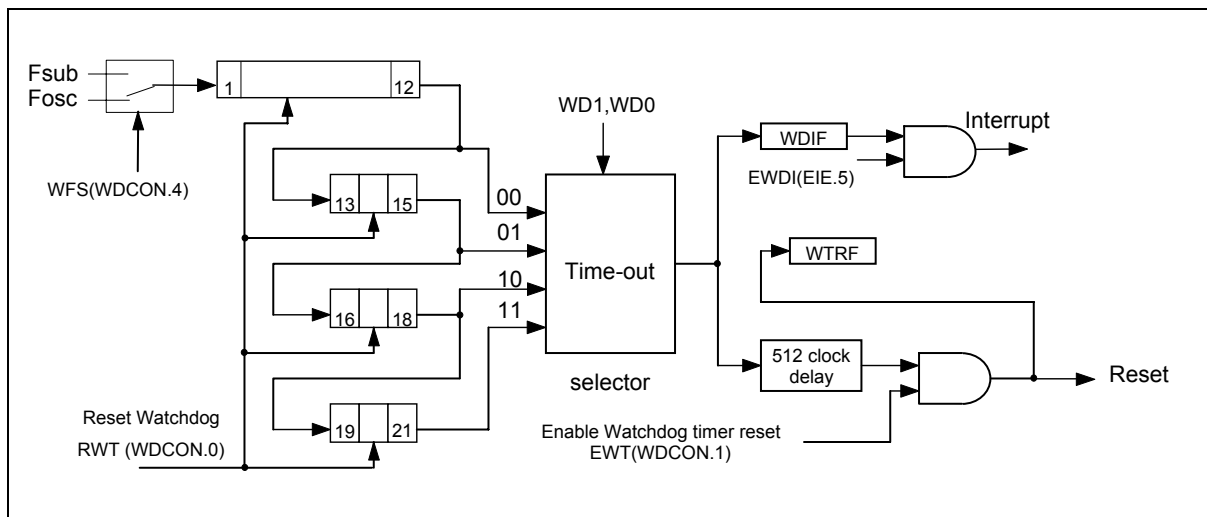

Figure 6-7 Watchdog Timer



The Watchdog timer should first be restarted by using RWT. This ensures that the timer starts from a known state. The RWT bit is used to restart the watchdog timer. This bit is self-clearing, i.e. after writing a 1 to this bit the software will automatically clear it. The watchdog timer will now count clock cycles. The time-out interval is selected by the two bits WD1 and WD0 (CKCON.7 and CKCON.6). When the selected time-out occurs, the Watchdog interrupt flag WDIF (WDCON.3) is set. After the time-out has occurred, the watchdog timer waits for an additional 512 clock cycles. The software must issue a RWT to reset the watchdog before the 512 clocks have elapsed. If the Watchdog Reset EWT (WDCON.1) is enabled, then 512 clocks after the time-out, if there is no RWT, a system reset due to Watchdog timer will occur. This will last for two machine cycles, and the Watchdog timer reset flag WTRF (WDCON.2) will be set. This indicates to the software that the watchdog was the cause of the reset.

When used as a simple timer, the reset and interrupt functions are disabled. The timer will set the WDIF flag each time the timer completes the selected time interval. The WDIF flag is polled to detect a time-out and the RWT allows software to restart the timer. The Watchdog timer can also be used as a very long timer. The interrupt feature is enabled in this case. Every time the time-out occurs an interrupt will occur if the global interrupt enable EA is set.

**Table 6 Time-out values for the Watchdog timer**

WD1	WD0	WATCHDOG INTERVAL	NUMBER OF CLOCKS	FOSC = 3.579545 MHZ	FOSC = 32768 HZ	RESET OF CLOCKS
0	0	$2^{12}$	4096	1.14 mS	0.125 S	4608
0	1	$2^{15}$	32786	9.15 mS	1 S	33280
1	0	$2^{18}$	262144	73.23 mS	8 S	262656
1	1	$2^{21}$	2097152	585.87 mS	64 S	2097664

The Watchdog timer will be disabled by a power-on/fail reset. The Watchdog timer reset does not disable the watchdog timer, but will restart it. In general, software should restart the timer to put it into a known state.

The control bits that support the Watchdog timer are discussed below.

#### WATCHDOG CONTROL

**WDIF:** WDCON.3 - Watchdog Timer Interrupt flag. This bit is set whenever the time-out occurs in the watchdog timer. If the Watchdog interrupt is enabled (EIE.5), then an interrupt will occur (if the global interrupt enable is set and other interrupt requirements are met). Software or any reset can clear this bit.

**WTRF:** WDCON.2 - Watchdog Timer Reset flag. This bit is set whenever a watchdog reset occurs. This bit is useful for determining the cause of a reset. Software must read it, and clear it manually. A Power-fail reset will clear this bit. If EWT = 0, then this bit will not be affected by the watchdog timer.

**EWT:** WDCON.1 - Enable Watchdog timer Reset. This bit when set to 1 will enable the Watchdog timer reset function. Setting this bit to 0 will disable the Watchdog timer reset function, but will leave the timer running



RWT: WDCON.0 - Reset Watchdog Timer. This bit is used to clear the Watchdog timer and to restart it. This bit is self-clearing, so after the software writes 1 to it the hardware will automatically clear it. If the Watchdog timer reset is enabled, then the RWT has to be set by the user within 512 clocks of the time-out. If this is not done then a Watchdog timer reset will occur.

### CLOCK CONTROL

WD1, WD0: CKCON.7, CKCON.6 - Watchdog Timer Mode select bits. These two bits select the time-out interval for the watchdog timer. The reset time is longer 512 clocks time than the interrupt time-out value.

The default Watchdog time-out is  $2^{12}$  clocks, which is the shortest time-out period. The EWT, WDIF and RWT bits are protected by the Timed Access procedure. This prevents software from accidentally enabling or disabling the watchdog timer. More importantly, it makes it highly improbable that errant code can enable or disable the watchdog timer.

## 6.9 Serial Port 1

The P4.0 and P4.1 can be used as an 8-bit serial input/output port1. P4.0 is the serial port 1 clock I/O pin and P4.1 is the serial port 1 data I/O pin. The serial port 1 is controlled by SCON1 register which is described as below.

SF1: Serial port 1 interrupt flag. When an 8-bits data are transit completely, SF1 is set by hardware. SF1 is cleared when serial interrupt1 routine is executed or cleared by software.

REN1: Set REN1 from 0 to 1 to start the serial port1 to receive 8-bit serial data.

SFQ: SFQ = 0 Serial clock output frequency is equal to  $f_{OSC} / 2$   
 SFQ = 1 Serial clock output frequency is equal to  $f_{OSC} / 256$

SEDG: SEDG = 0 Serial data latched at falling edge of clock, SCLK=Low initially.  
 SEDG = 1 Serial data latched at rising edge of clock, SCLK=High initially.

CLKIO: CLKIO = 0 P4.0(SCLK) work as output mode  
 CLKIO = 1 P4.0(SCLK) work as input mode

SIO: SIO = 0 P4.0 & P4.1 work as normal I/O pin  
 SIO = 1 P4.0 & P4.1 work as Serial port1 function

Any instruction causes a write to SBUF1 will start the transmission of serial port 1. As the REN1 is from 0 to 1, the serial port 1 begins to receive a byte into SBUF1 in the frequency of the serial clock. REN1 could be cleared by software after receive function begins. The LSB is transmitted/ received first. The I/O mode of serial clock pin is controlled by CLKIO. User has to take care the initial state of the serial port pins.

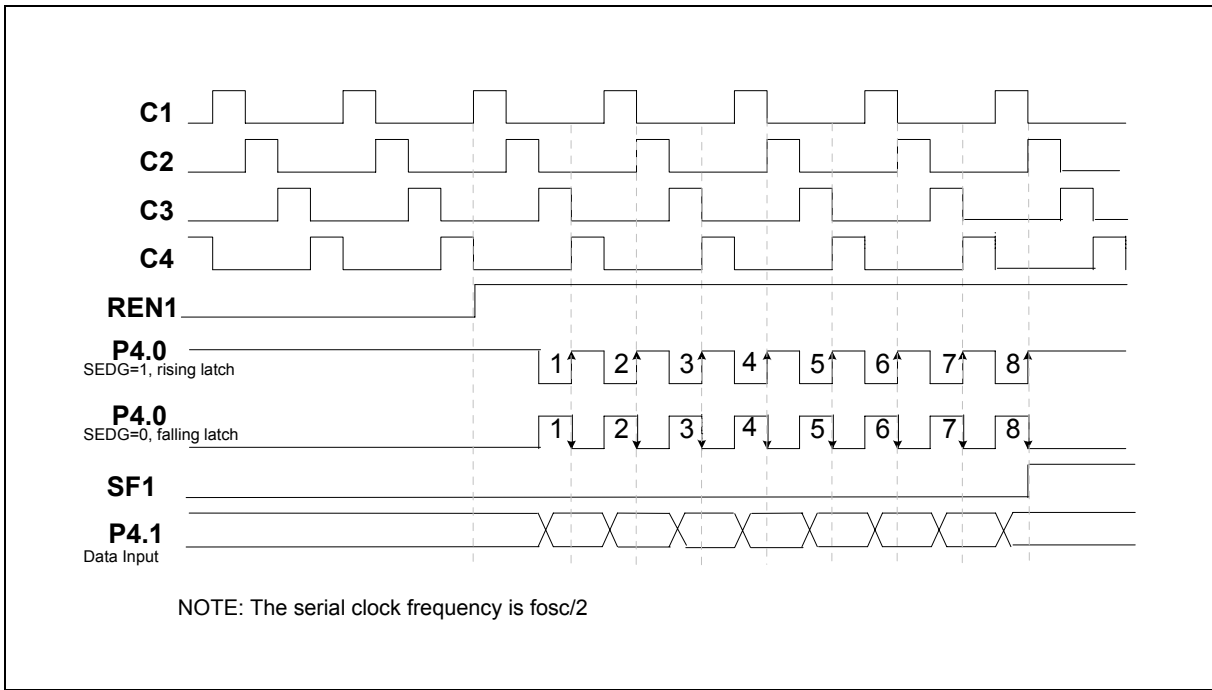

Figure 6-8 Timing of the Serial Port 1 Input Function

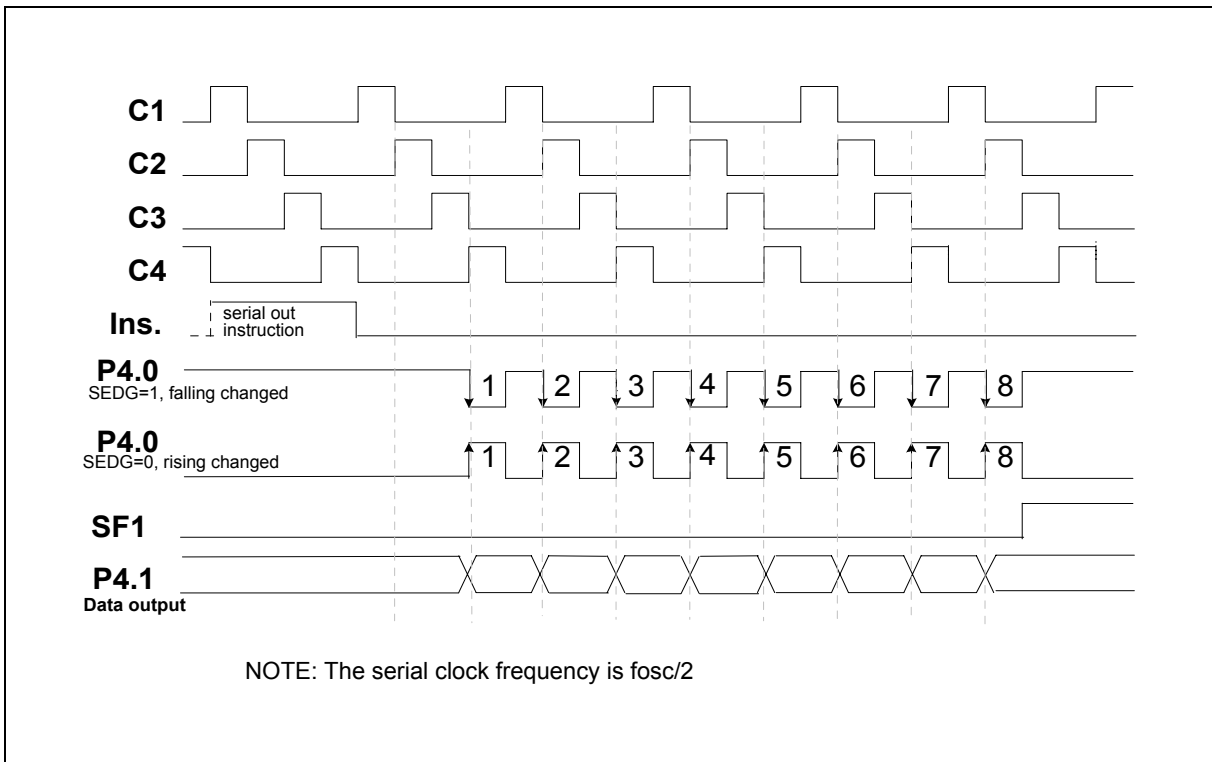

Figure 6-9 Timing of the Serial Port 1 Output Function

### 6.10 Comparator

A built-in comparator can compare the analog signal. There is an analog input paths from pin VNEG. Two reference inputs; one is from pin VPOS and other is from regulator output. When the voltage of positive input is higher than the negative input, the comparator output will be high. The RESEC(COMPR.3) is the result of the comparison. An internal rising signal on RESC produces interrupt flag of COMPF (EXIF.4). The flag COMPF is cleared when comparator interrupt routine is executed or cleared by software. Set COMPEN to enable the comparator function.

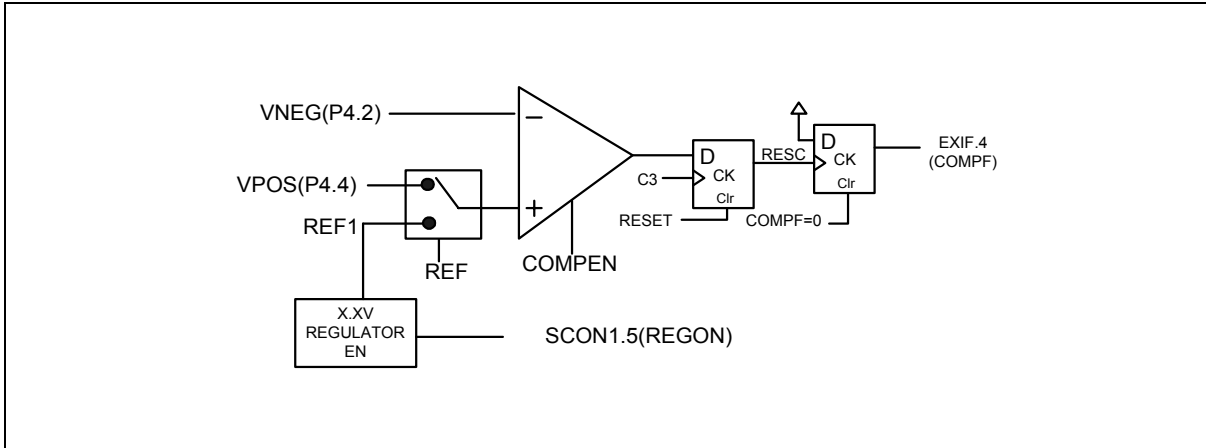

Figure 6-10 The Configuration of Comparator

The output voltage of the regulator is tunable by 4 bits in regulator voltage control register (REGVC). When REGVC is equal to 0Ah, the output voltage is 1.0V. The higher value of REGVC the lower voltage output of regulator. The adjustable voltage range is about from 0.72V to 1.48V. The variation of the voltage depends on the  $V_{DD}$ . Following is the table of REGVC vs. regulator voltage.

Regvc	00	01	02	03	04	05	06	07	08	09	0ah	0bh	0ch	0dh	0eh	0fh
No Loading(3V)	1.497	1.4464	1.3941	1.3426	1.2899	1.238	1.186	1.1352	1.081	1.029	<b>0.976</b>	0.924	0.869	0.815	0.762	0.7112
No Loading(5V)	1.500	1.449	1.397	1.345	1.292	1.241	1.188	1.137	1.083	1.031	<b>0.978</b>	0.925	0.87	0.816	0.763	0.712

### 6.11 DTMF Generator

W925E/C240 provides a DTMF generator, which outputs the dual tone multi-frequency signal to the DTMF pin. The DTMF generator can work well at the operating frequency of 3.58MHz. A DTMF generator register DTMFG controls the DTMF output and specifies the desired low/high frequency. The tones are divided into two groups (low group and high group). When the generator is disable, the DTMF pin is in tri-state. The relation between the DTMF signal and the corresponding touch-tone keypad is shown in Figure 6-11.



	<b>C1</b>	<b>C2</b>	<b>C3</b>	<b>C4</b>	<b>Row/Col</b>	<b>Frequency</b>
<b>R1</b>	1	2	3	A	R1	697 Hz
<b>R2</b>	4	5	6	B	R2	770 Hz
<b>R3</b>	7	8	9	C	R3	852 Hz
<b>R4</b>	*	0	#	D	R4	941 Hz
					C1	1209 Hz
					C2	1336 Hz
					C3	1477 Hz
					C4	1633 Hz

Figure 6-11 The Relation Between DTMF and Keypad

Bit:	7	6	5	4	3	2	1	0
	-	DTGE	HE	LE	L1	L0	H1	H0
Mnemonic: DTMFG								Address: BAh

L1	L0	H1	H0	SELECTED TONE
x	x	0	0	1209Hz
x	x	0	1	1336Hz
x	x	1	0	1477Hz
x	x	1	1	1633Hz
0	0	x	x	697Hz
0	1	x	x	770Hz
1	0	x	x	852Hz
1	1	x	x	941Hz

LE: Enable low group frequency output.

HE: Enable high group frequency output.

DTGE: Enable dual tone output to DTMF pin.

### 6.12 FSK Generator

W925E/C240 provides a FSK generator, which outputs the FSK signal to the DTMF pin. The FSK output share with DTMF output pin. It can out FSK signal with 1200Hz baud rate of ITU-T V.23 or Bellcore 202 signal. A FSK transmit data register (FSKTB) specifies the desired output data. The FSK Transmit Control Register (FSKTC) can control whether the FSK signal will be output or not. The relation timing is shown in Figure 6-12



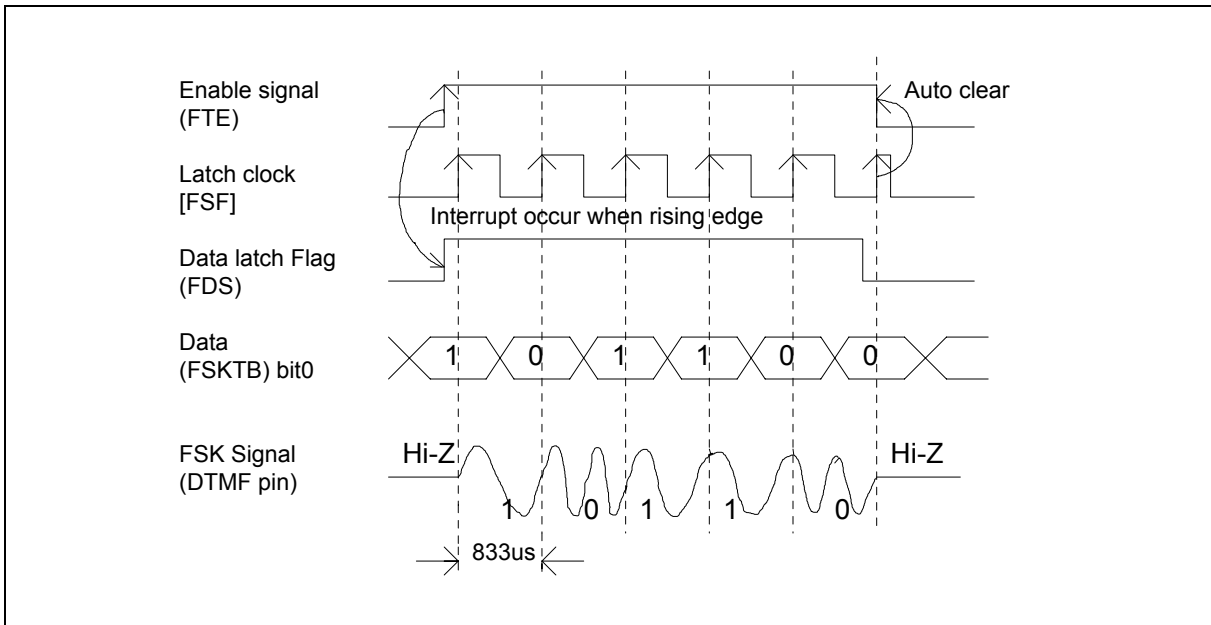

Figure 6-12 FSK Modulator

**FSK TRANSMIT CONTROL REGISTER**

(initial = 00H)

Bit:	7	6	5	4	3	2	1	0
	FTE	FTM	FDS	-	-	-	LO1	LO0

Mnemonic: FSKTC

Address: C6h

FTE: FSK transmit Enable. Enable = 1, Disable = 0

FTM: FSK signal Standard. Bellcore 202 = 1, V.23 = 0

FDS: FSK data sending status

LO0, LO1: FSK transmit level option

FSK output level	LO1	LO0
150mV	0	0
120mV	0	1
95mV	1	0
75mV	1	1

**FSK TRANSMIT DATA BUFFER**

(initial=00H)

Bit:	7	6	5	4	3	2	1	0
	FSKTB.7	FSKTB.6	FSKTB.5	FSKTB.4	FSKTB.3	FSKTB.2	FSKTB.1	FSKTB.0

Mnemonic: FSKTB

Address: C7h

FSKTB.0: Only this bit will be latched and send out as FSK signal



When FTE enable will set the FDS to high to enable the internal latch clock in 1200Hz. When FDS is in high state, FSKTB bit0 will be sent out by FSK modulator at the rising edge of latch clock. FDS could be cleared by software to inform no more data will be sent out after the last bit is sent completely. If the FDS is cleared then FTE will become low at next rising latch clock to disable FSK modulator and clear FDS by hardware automatically.

When FTE is set, FSK modulation flag (FSF) will be set at every rising edge of latch clock to produce an interrupt shared with CID interrupt routine. If a CID interrupt occurs, user can check FSF to know if this interrupt is caused by FSK modulator. The only way to stop FSK signal immediately is to disable FTE by software.

### 6.13 I/O Ports

There are five 8-bits ports named from P0 to P4 in W925E/C240. All ports can be configured as input or output mode. Except P0, every port has pull high resistor enable/disable by PxH register. After reset the initial state of each port is in input mode and the value of the registers from P0 to P3 are FFh. The I/O port is described as below:

**P0:** I/O mode is controlled by P0IO. Only **P0 output as open drain mode** and without pull high resistor.

**P1:** I/O mode is controlled by P1IO. Pull high is controlled by P1H. **P1.0~P1.3 work as INT2, P1.4~P1.7 work as INT3. Falling edge** on P1 pins to produce INT2 and INT3 flag. P1 is configured as INT2/INT3 by P1EF register.

**P2:** I/O mode is controlled by P2IO. Pull high is controlled by P2H.

**P3:** I/O mode is controlled by P3IO. Pull high is controlled by P3H.

P3.5	T1	Timer/counter 1 external count input
P3.4	T0	Timer/counter 0 external count input
P3.3	$\overline{\text{INT1}}$	External interrupt 1
P3.2	$\overline{\text{INT0}}$	External interrupt 0

**P4:** I/O mode is controlled by P4IO. Pull high is controlled by P4H.

Special function of P4 is described below.

P4.7-5	I/O	Normal I/O
P4.4	VPOS	Positive input of the comparator
P4.2	VNEG	Negative input of the comparator
P4.1	SDATA	Serial port output
P4.0	SCLK	Serial port input

### 6.14 Divider

A built-in 13/14-bit binary up counter designed to generate periodic interrupt. The clock source is from sub-oscillator. When the frequency of sub-crystal is 32768Hz, it provides the divider interrupt in the period of 0.25/0.5 second. Bit DIVS controls the degree of divider. When DIVA is high to enable the divided counter, when DIVA is low to reset divider and stop counting. As the divider overflows, the divider interrupt flag DIVF is set. DIVF is clear by software or serving divider interrupt routine.

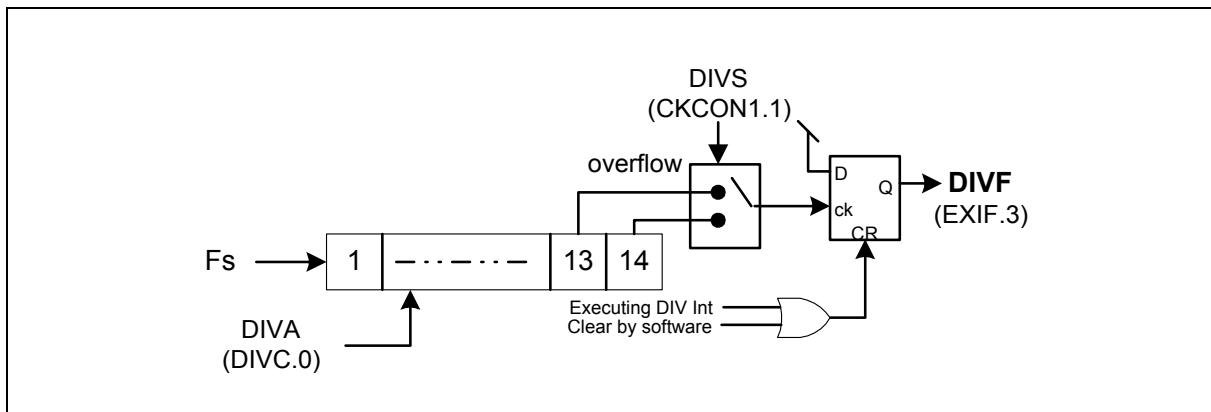

Figure 6-13 13/14-bit Divider

### 6.15 Calling Identity Delivery (CID)

W925E/C240 provides type I and type II of CID system. Type I is on-hook calling with CID message and type II is off-hook call on waiting. The CID function includes FSK decoder, dual tone alert signal detector, ring detector and DTMF receiver. The FSK demodulation function can demodulate Bell 202 and ITU-T V.23 Frequency Shift keying (FSK) with 1200-baud rate. The Tone Alert Signal detect function can detect dual tones of Bellcore Customer Premises Equipment(CPE) Tone Alerting Signal(CAS) and BT Idle State and Loop State Tone Alert Signal. The line reversal for BT, ring burst for CCA or ring signal for Bellcore can be detected by ring detector. It is compatible with Bellcore TR-NWT-000030 & ST-TSV-002476, British Telecom(BT) SIN227, U.K. Cable Communications Association(CCA) specification. The DTMF receiver can be programmed as DTMF decoder to decode 16 DTMF signals or tone detector to detect the signal which frequency is in DTMF band. The tone detector can be an auxiliary detector to improve the performance of detecting tone-alerting signal(CAS), said as talk down-off, in type II system.

The FSK decoder, alert tone detector and DTMF receiver can be enable/disable individually by the bits of FSKE, CASE and DTMFE in FSK DATA REGISTER(FSKDR). CIDE is the global control bit to enable/disable FSK decoder, alert tone detector and DTMF receiver. However, the ring detector is always active.

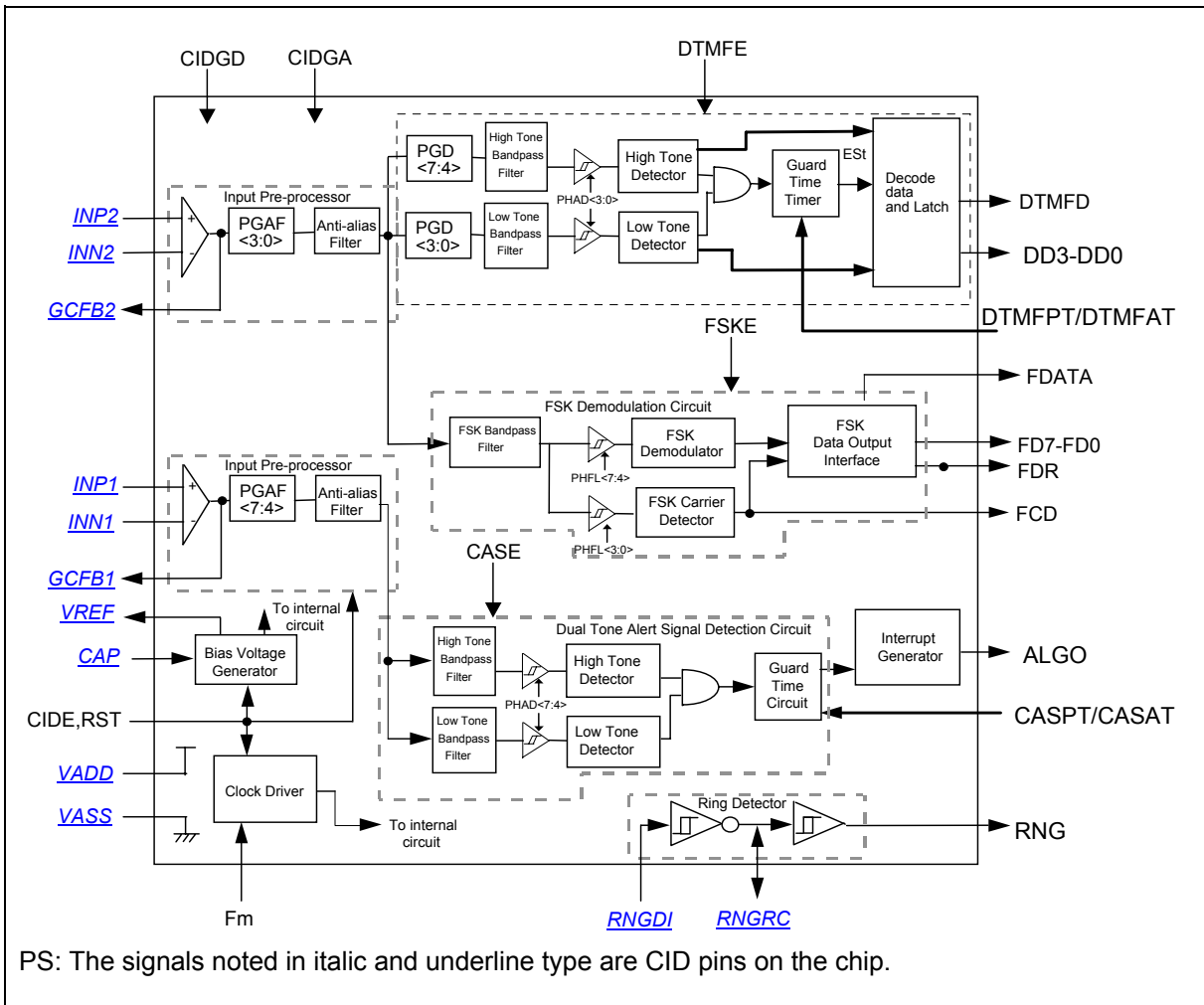

Figure 6-14 The CID Block Diagram

## Ring Detector

The application circuit in Figure 6-15 illustrates the relationship between the RNGDI, RNGRC and RNG signals. The combination of RNGDI and RNGRC is used to detect an increase of the RNGDI voltage from ground to a level above the Schmitt trigger high going threshold voltage  $V_{T+}$ .

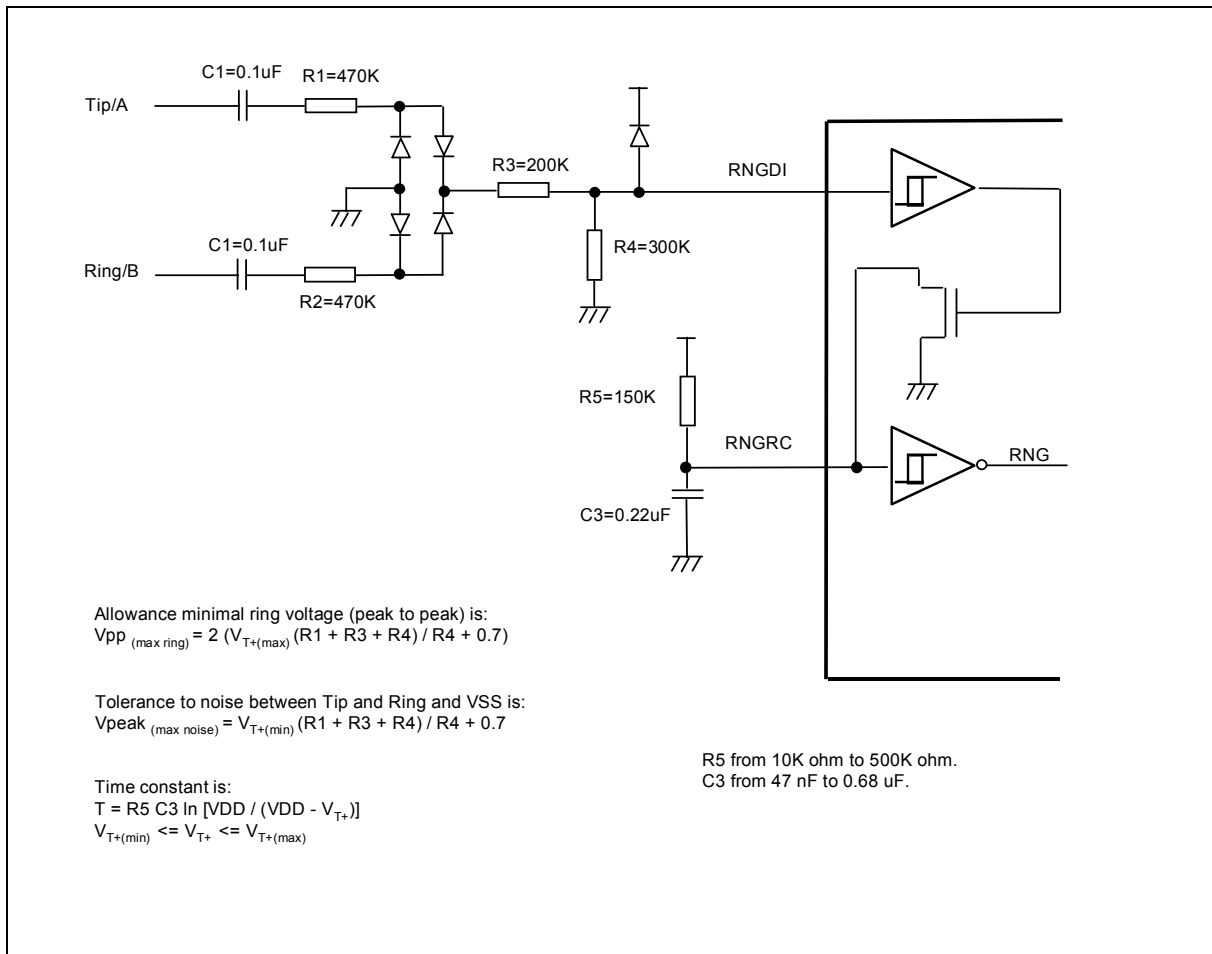

Figure 6-15 Application Circuit of the Ring Detector

The RC time constant of the RNGRC pin is used to delayed the output pulse of the RNG flag for a low going edge on RNGDI. This edge goes from above the  $V_{T+}$  voltage to the Schmitt trigger low going threshold voltage  $V_{T-}$ . The RC time constant must be greater than the maximum period of the ring signal, to ensure a minimum RNG high interval and to filter the ring signal to get an envelope output. The rising signal of RNG will set the bit RNGF(CIDFG.0) high to cause the CID flag(CIDF) high.

The diode bridge shown in Figure 6-15 works for both single ended ring signal and balanced ringing. The R1 and R2 are used to set the maximum loading and must be of equal value to achieve balanced loading at both the tip and ring line. R1, R3 and R4 form a resistor divider to supply a reduced voltage to the RNGDI input. The attenuation value is determined by the detection of minimal ring voltage and maximum noise tolerance between tip/ring and ground.

**Input Pre-Processor**

The input signal is processed by Input Pre-Processor, which is comprised of two OP amps and a bias source(VREF). The gain OP-amps are used to bias the input voltage with the VREF signal voltage. VREF is  $V_{AD}/2$  typically, this pin is recommended to connect a 0.1uF capacitor to  $V_{AS}$ . The gain adjustable OP amps are used to select the input gain by connecting a feedback resistor between GCFB and INN pins. Figure 6-16 shows the differential input configuration and Figure 6-17 shows the single-ended configuration.

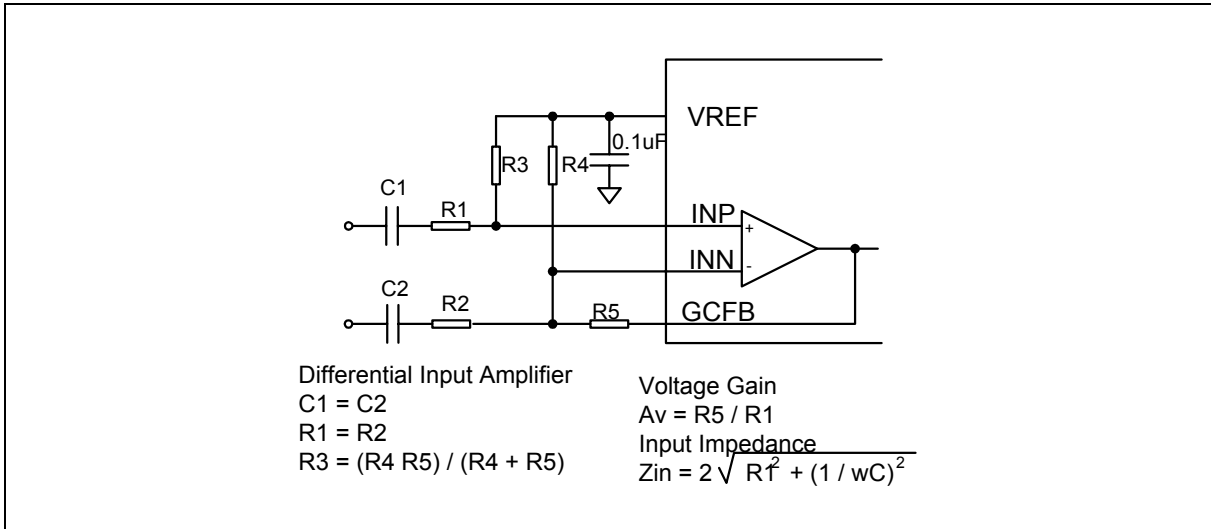

Figure 6-16 Differential Input Gain Control Circuit

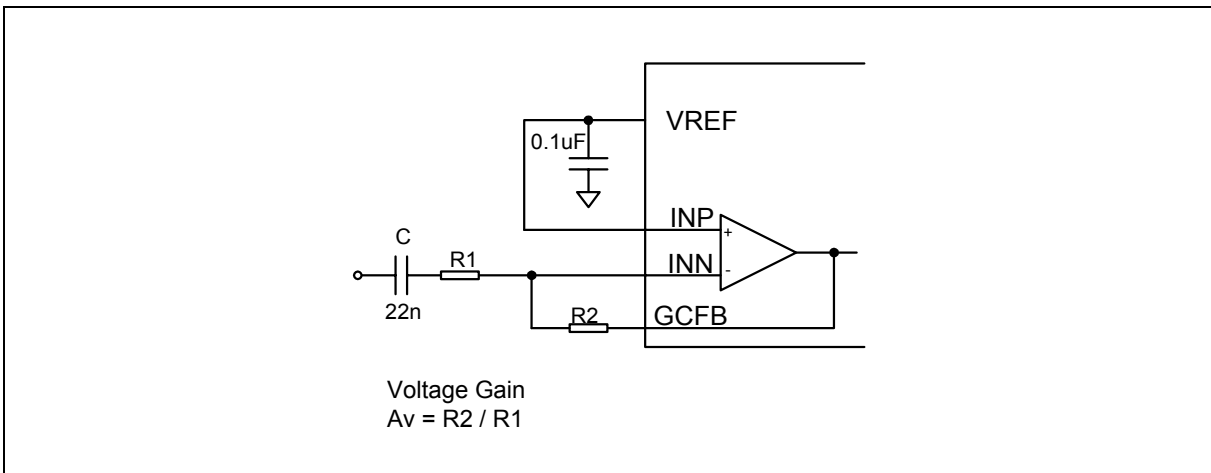

Figure 6-17 Single-Ended Input Gain Control Circuit

### CAS/DTAS Detection

In off-hook services (type II), the detection of CAS/DTAS will affect the quality of the call waiting service. When the CAS/DTAS is sent from far end, sometimes the near end user maybe still talking. The CPE must be able to detect the CAS/DTAS successfully in the presence of near end speech. To detect CAS/DTAS from telephone hybrid receiver pair improves the detection. However, in BT's on-hook CID system the CAS/DTAS detection is from Tip/Ring pair.

The dual tone alert signal is separated into high and low tones and detected by a high/low tone detector. When the alert tone is recognized by the detector, the bit ALGO will go high and the rising signal will set the bit ALGOF in CIDFG to produce the CID flag(CIDF). Figure 6-18 shows the guard time waveform of detecting alert tone. The total recognition time is  $t_{REC}=t_{DP}+t_{GP}$ , where  $t_{DP}$  is the tone present detect time and  $t_{GP}$  is the tone present guard time. The total absent guard time is  $t_{ABS}=t_{DA}+t_{GA}$  where  $t_{DA}$  is the tone absent detect time and  $t_{GA}$  is the tone absent guard time. The tone present/absent guard time is determined by guard-time timer, which the input clock period is 0.858mS. When the alert tone is detected, the internal signal ALGR will be set and the rising edge of ALGR resets the guard-time timer and the timer starts up counting from 00H. As the content of the timer is the same as the register CASPT, the timer stops counting and the bit ALGO will be set and the rising edge of ALGO triggers the flag ALGOF to become high. The counting of tone absent time is similar to the counting of tone present time but the falling edge of ALGR/ ALGO replaces the rising edge and the CASAT replaces the CASPT. The bit ALGO is controlled by hardware only. The flag ALGOF is set by rising edge of ALGO and cleared by software.

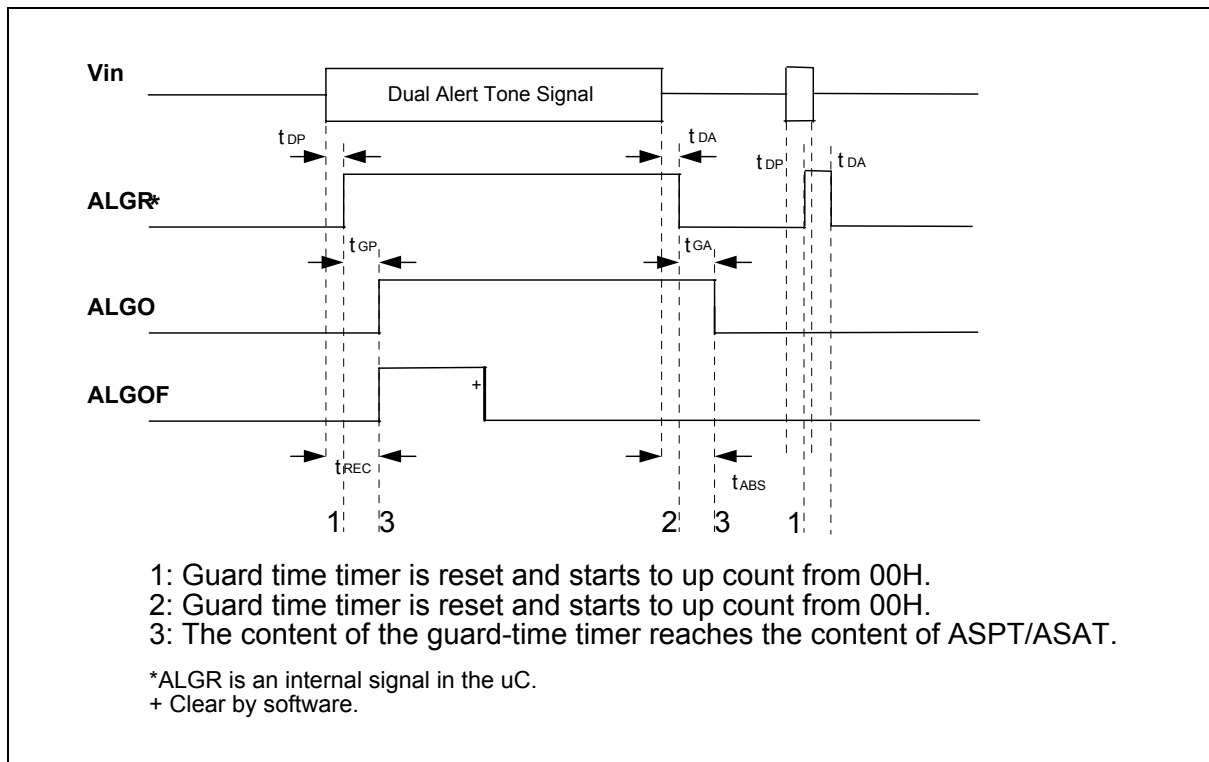

Figure 6-18 Guard Time Waveform of Alert Tone Signal Detection

## DTMF Decoder

The DTMF decoder shares the same input pre-processor with FSK decoder. The dual tone is separated into low group and high group by two SCFs (switched capacitor filter). The method of DTMF detection is the same as alert tone detection. The present/absent guard time is adjusted by registers DTMFPT/DTMFAT. As the DTMF signal is recognized and decoded, the bit DTMFD will be set and the decoded DTMF data is stored in bit0 to bit3 of register DTMFDR. The rising edge of DTMFD produces the flag DTMFDF. The bit DTMFD is controlled by hardware only. The flag DTMFDF is set by rising edge of DTMFD and cleared by software.

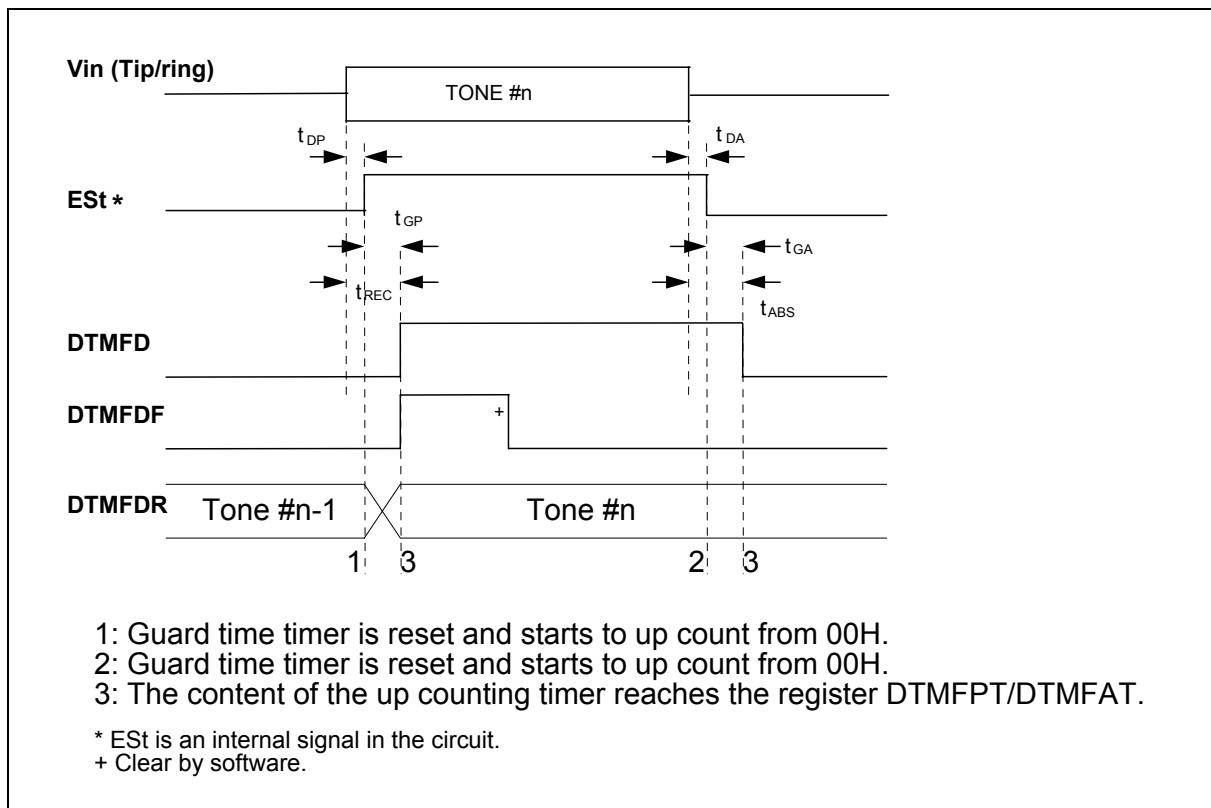

Figure 6-19 The Waveform of DTMF Detection

## Tone Detector

In off-hook state, said type II system, detecting tone alert signal(CAS) is easily interfered by human's voice or other noise in voice band. Sometimes the interference makes falsely recognizing a noise as a CAS(talk-off), or lost detecting a real CAS(talk-down). The DTMF can be programmed as a tone detector by setting bit 4 of DTMFR2. The frequency band of the tone detector is DTMF frequency from 697Hz to 1633Hz. Once the tone detector gets signals in the band, the bit of DTMFH or DTMFL in register DTMFDR will become high immediately. User can poll these 2 bits to check if the tone exists on the tip/ring. The input gain of tone detector is the same as DTMF receiver.





**FSK Decoder**

The FSK carrier detector provides an indication of the present of a signal within the FSK frequency band. If the output amplitude of the FSK band-pass filter is sufficient to be detected continuously for 8 mS, the FSK carrier detected bit FCD will go high and it will be released if the FSK band-pass filter output amplitude is not able to be detected for greater than 8 mS. The 8 mS is the hysteresis of the FSK carrier detector. Figure 6-20 shows the timing of FSK carrier detection.

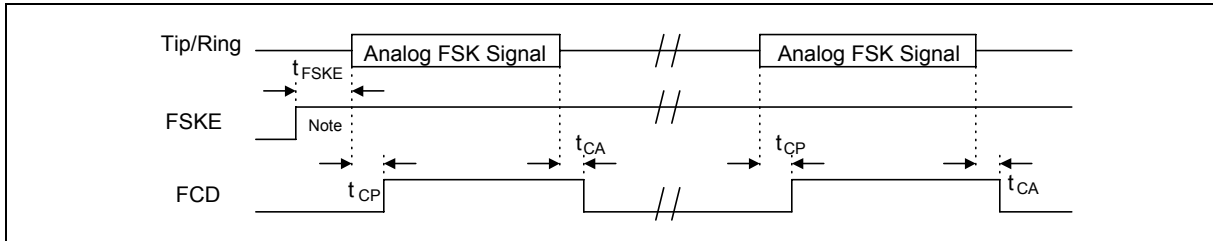
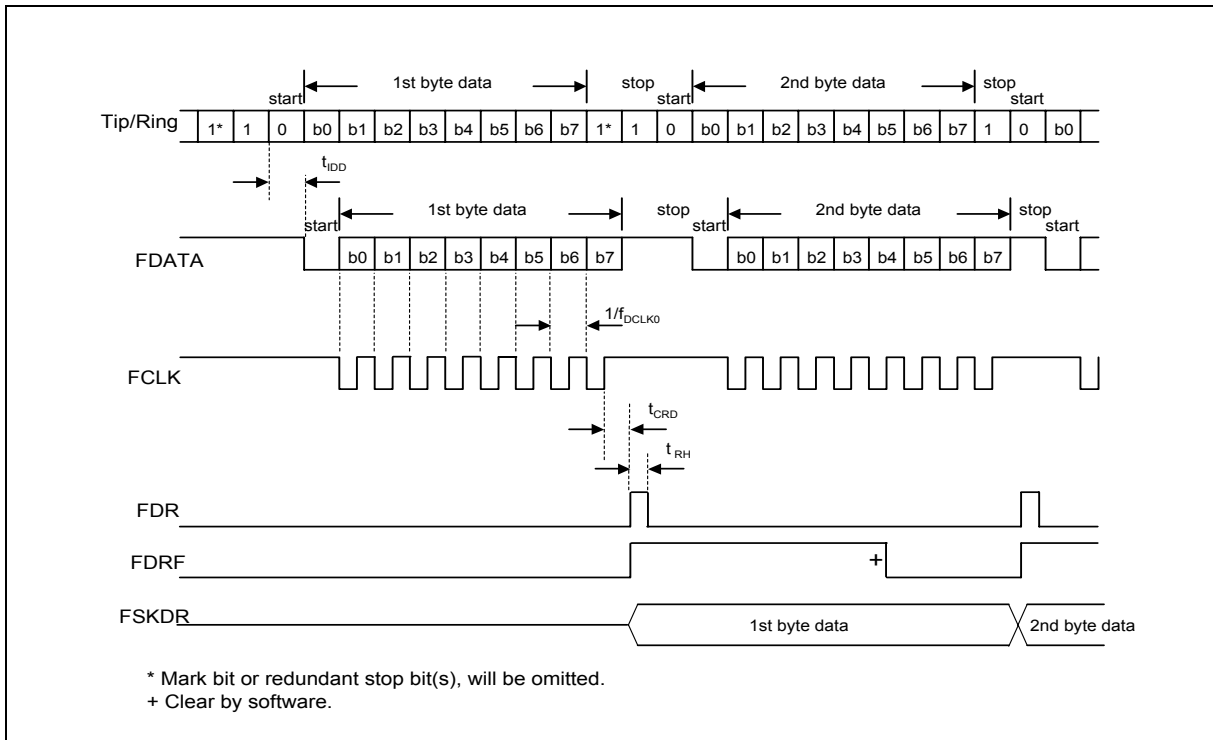

Figure 6-20 FSK Detection Enable and FSK Carrier Present and Absent Timing

The FSK demodulation function can demodulate Bell 202 and ITU-T V.23 Frequency Shift keying (FSK) with 1200-baud rate. When the decoder receives the FSK serial data, the serial data will be demodulated into bit FDATA with 1200-baud rate in the mean time the synchronous clock signal is output to the bit FCLK. As the decoder receives one byte, the internal serial-to-parallel circuit sets the bit FDR and converts the 8-bit serial data into the byte register FSKDR. The rising edge of bit FDR will set the flag FDRF to produce CID interrupt but FDRF is cleared by software. User can get the FSK data by reading register FSKDR or sampling the bit FDATA. The timing of FSK demodulation is shown in Figure 6-21.



\* Mark bit or redundant stop bit(s), will be omitted.  
 + Clear by software.

Figure 6-21 Serial Data Interface Timing of FSK Demodulation

**CID Input Gain Control**

The CID input gain and input hysteresis are controllable by internal CID gain control registers. CIDGD and CIDGA registers determine the 6 internal CID gain control registers. CID gain control data register (CIDGD) presents the data bus. The lower 3 bits of CID gain control address register (CIDGA) present the address. The rising edge of CIDGA.4 will latch the CIDGD in the corresponding internal CID gain control register. The 6 internal CID gain control registers are addressed as following table. Setting the 6 registers as the suggestion value guarantees the CID spec.

ADDRESS (CIDGA.2-0)	INTERNAL CID GAIN CONTROL REGISTER	SUGGESTION VALUE
000	<b>DTMFR1:</b> DTMF register1	0000 0001B
001	<b>DTMFR2:</b> DTMF register2	011X 0001B <sup>†</sup>
002	<b>PGAF:</b> Programmable gain control alert tone and FSK	99H
003	<b>PGAD:</b> Programmable gain control DTMF	A7H
004	<b>PHAD:</b> Programmable hysteresis alert tone and DTMF	35H
005	<b>PHFL:</b> Programmable hysteresis FSK and low pass filter	33H

<sup>†</sup> X = 0 DTMF receiver works a DTMF decoder, X=1 DTMF receiver works as a tone detector.

The signals to set internal CID gain control registers is shown in Figure 6-22

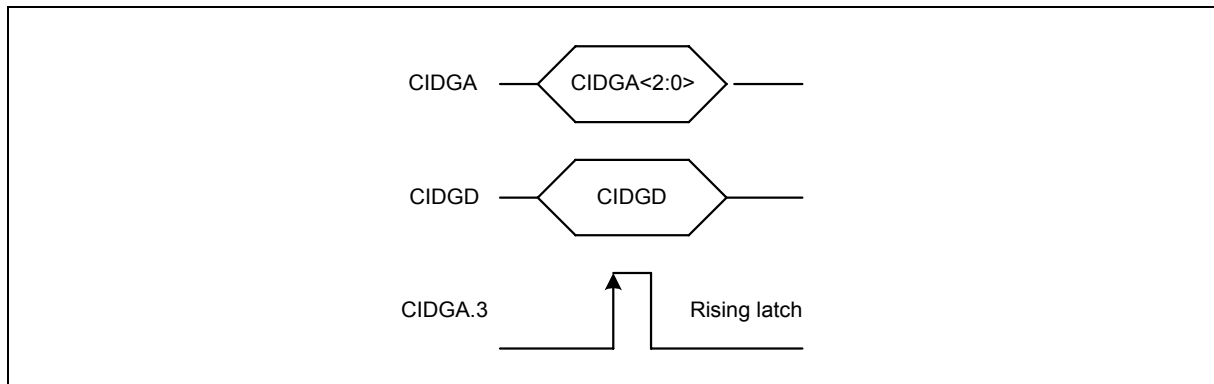

Figure 6-22 Internal CID Gain Control Register Setting Waveform

**DTMFR1**

DTMFR1[7:4] are reserved bits and must be 0000b.

BIT3~BIT0	ACCEPTABLE ERROR PERCENTAGE TO SAMPLE 4 PERIOD OF ROW FREQ.
0000	0.6% (default)
0001	2.5%
001X	3.5%
01XX	Reserved
1XXX	Reserved



**DTMFR2**

BIT3~BIT0	ACCEPTABLE ERROR PERCENTAGE TO SAMPLE 4 PERIOD OF COL FREQ.
0000	0.5% (default)
0001	1.5%
001X	2.5%
01XX	Reserved
1XXX	Reserved

The acceptable error percentage may have small variation by different test environments.

DTMFR2.4 = 0	DTMF receiver works as a DTMF receiver
DTMFR2.4 = 1	DTMF receiver works as a tone detector
DTMFR2.5 = 0	DTMF PT counter is up counter type, detected frequency changed does not effect counter
DTMFR2.5 = 1	DTMF PT counter is up counter type, detected frequency changed resets DTMF PT counter
DTMFR2.6 = 0	DTMF AT counter is up-down counter type, up counting when no DTMF detected, down counting if DTMF detected again.
DTMFR2.6 = 1	DTMF AT counter is up counter type, up counting when no DTMF detected, pause counting if DTMF detected again.
DTMFR2.7: reserved	

There are 4 programmable gain arrays, shown in Figure 6-14, are determined by Low/High nibbles of PGxx. The following table lists the input gain corresponding to the value of L/H nibble of PGxx.

X	$20 \text{ LOG}((40+15*X)/(230-(40+15*X))) \text{ DB}$	X	$20 \text{ LOG}((40+15*X)/(230-(40+15*X))) \text{ DB}$
0	-13.53	6	2.28
1	-10.05	7	4.64
2	-7.18	8	7.18
3	-4.64	9	10.05
4	-2.28	10	13.53
5	0.00	X is the value of L/H nibble of PGxx	

There are 4 programmable hysteresis input buffer, shown in Figure 6-14, are determined by Low/ High nibbles of PHxx. The hysteresis control formulas are list below.

Alert tone hysteresis	HAT = 13mv + 3mv*X	X = PHAD<7:4>
DTMF hysteresis	HDTMF = 6mv + 3mv*X	X = PHAD<3:0>
FSK hysteresis	HFSK = 13mv + 3mv*X	X = PHFL<7:4>
FSK detector hysteresis	HFSKD = 13mv + 3mv*X	X = PHFL<3:0>



### 7. APPLICATION CIRCUIT

The analog interface circuit of W925E/C240 shown in Figure 7-1 is a typical CPE system. The gain control op-amp is set to unit gain to allow the electrical characteristics to be met in this application circuit.

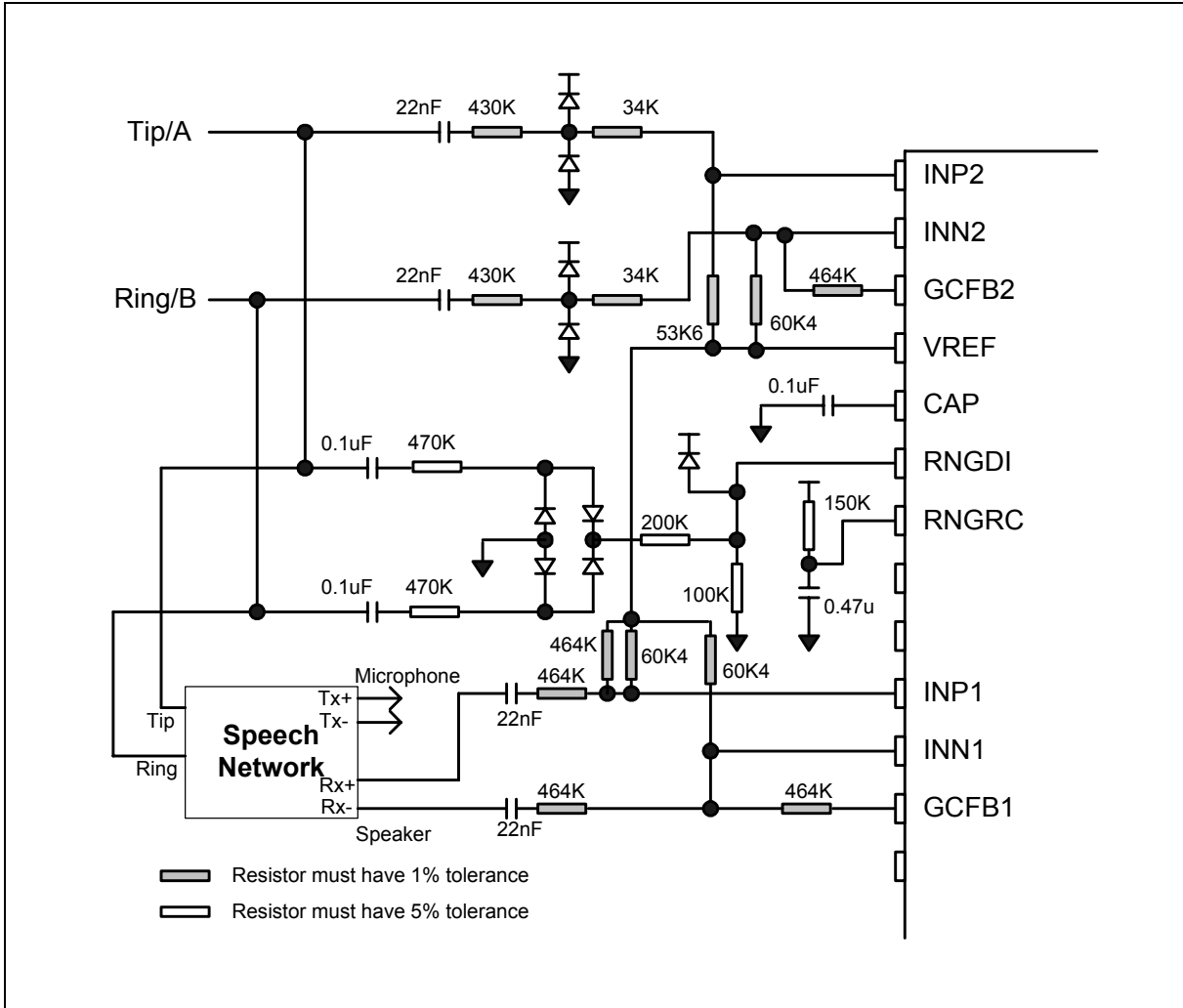

Figure 7-1 Application Circuit of CID



**Application Environment**

There are three major timing differences for CID sequences, Bellcore, BT and CCA. Figure 7-2 is the timing diagram for Bellcore on-hook data transmission and Figure 7-3 is the timing diagram for the Bellcore off-hook data transmission. Figure 7-4 is the timing diagram for the BT caller display service on-hook data transmission and Figure 7-5 is the timing diagram for the BT caller display service off-hook data transmission. Figure 7-6 is the timing diagram for the CCA caller display service for on-hook data transmission. The CID flag (CIDF) must be cleared by software when each time the CID interrupt routine is serviced. The CID global enable signal (CIDE) must be set high.

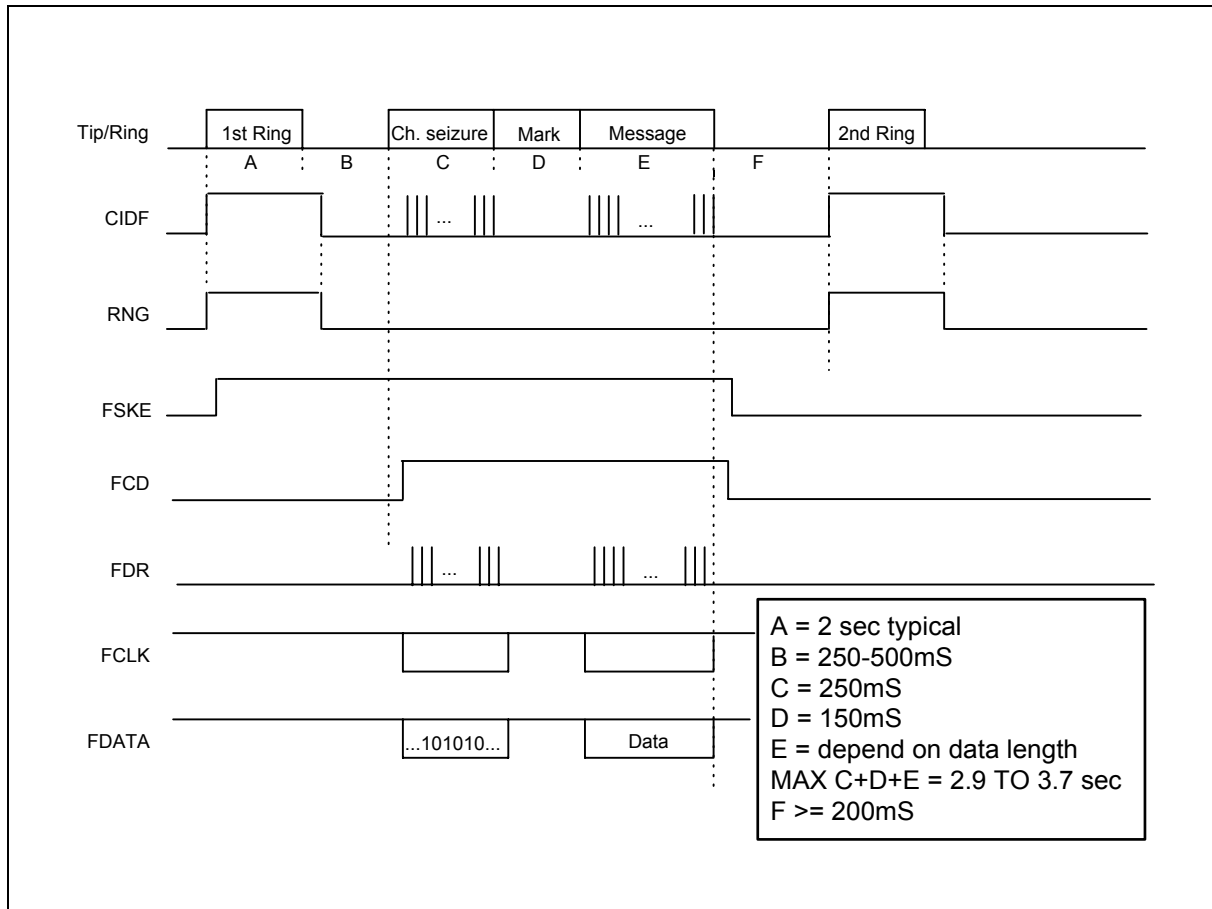

Figure 7-2 Input and Output Timing of Bellcore On-hook Data Transmission

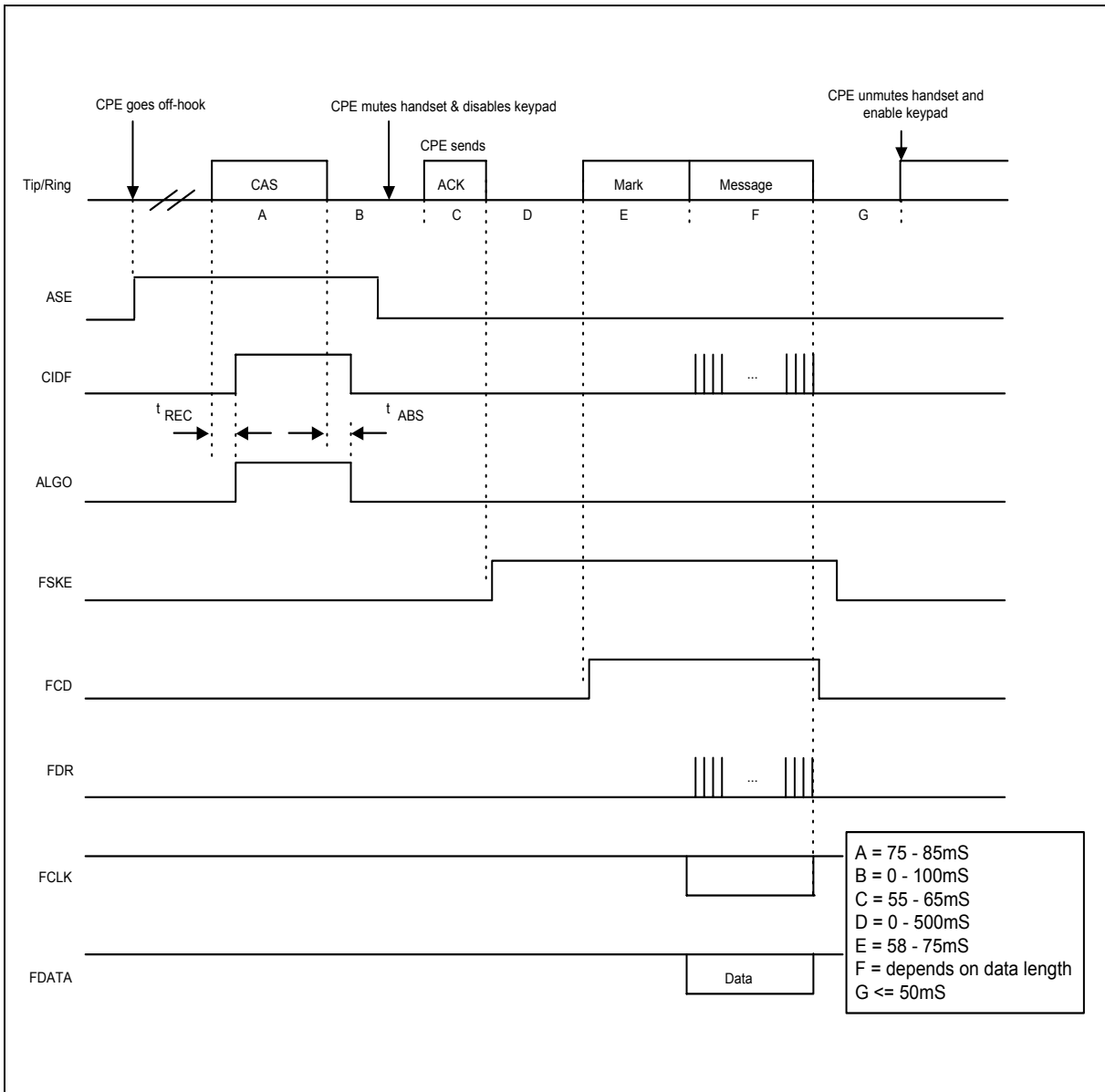

Figure 7-3 Input and Output Timing of Bellcore Off-hook Data Transmission

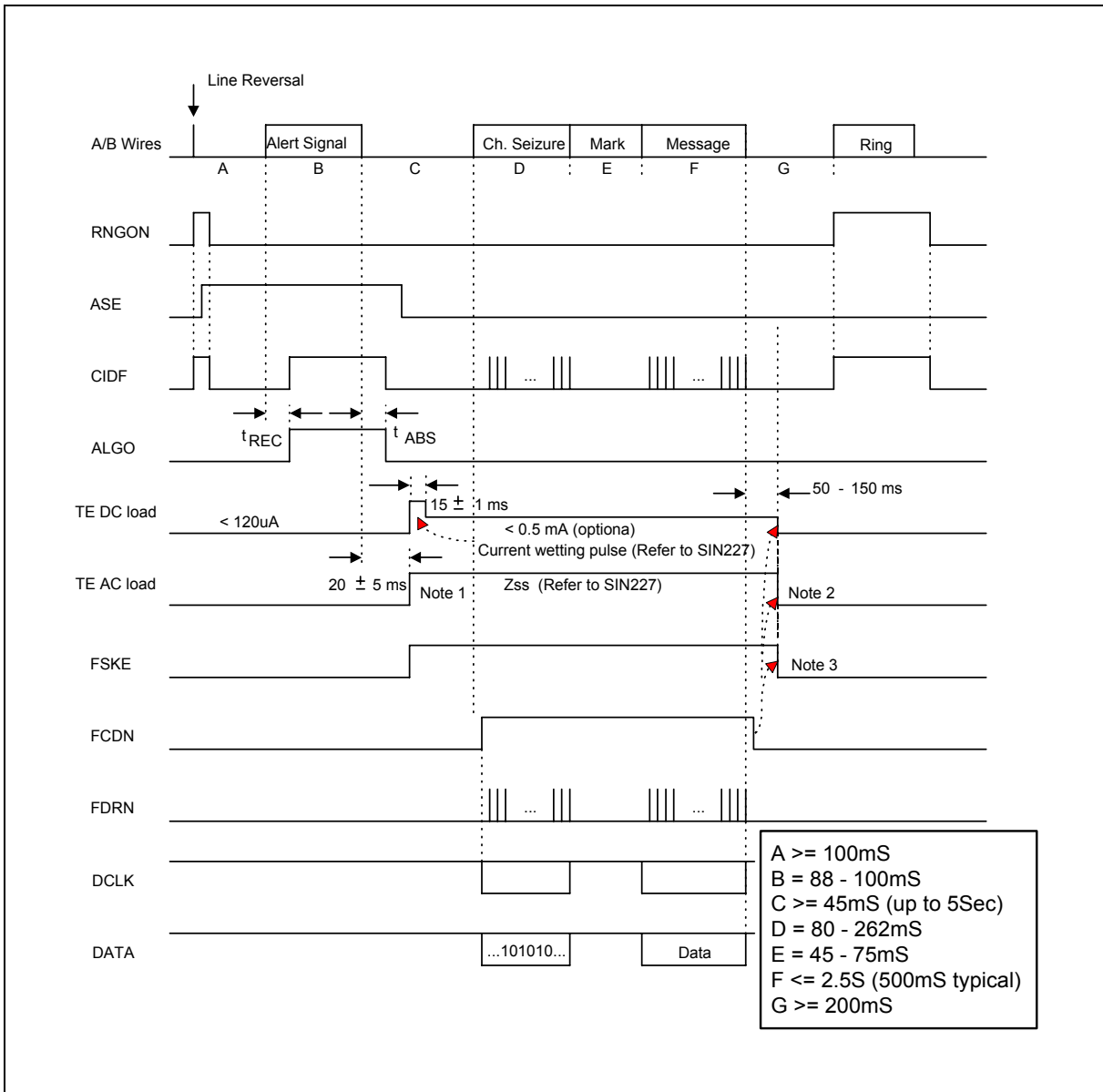

Figure 7-4 Input and Output Timing of BT Idle State (On-hook) Data Transmission

**Note:**

1. SIN227 specifies that the AC and DC loads should be applied at  $20 \pm 5$ ms after the end of the dual tone alert signal.
2. SIN227 specifies that the AC and DC loads should be removed between 50 – 150ms after the end of the FSK signal.
3. The FSKE bit should be set low to disable the FSK decoder when FSK is not expected. The tone alerting signal speech and the DTMF tones are in the same frequency band as the FSK signal.

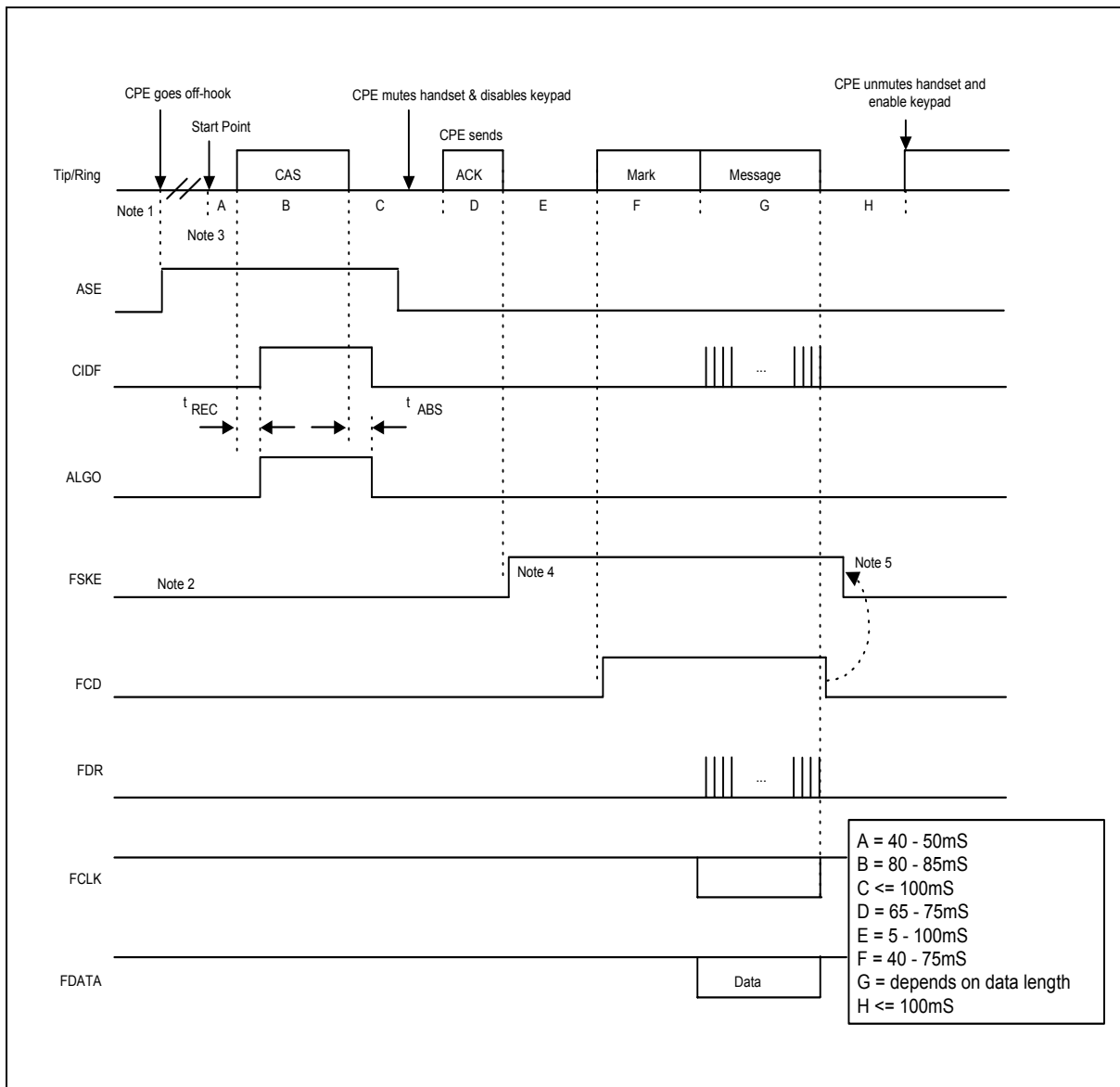

Figure 7-5 Input and Output Timing of BT Loop State (Off-hook) Data Transmission

**Notes:**

1. In a CPE where AC power is not available, the designer may choose to switch over to line power when the CPE goes off-hook and use battery power while on-hook.
2. The FSKE bit may be set low to prevent the alert tone, speech or other FSK in-band noise decoded by FSK demodulator and give false data when the dual tone alert signal is expected. If the FSKE pin cannot controlled by micro-controller, the FSKE bit must always placed in high state and the micro controller must give up the FSK decoded data when the FSK signal is not expected.
3. The exchange will have already disabled the speech path to the distant customer in both transmission directions.
4. The FSKE should be set high as soon as the CPE has finished sending the acknowledge signal ACK.
5. The FSKE may be set low after the last byte (check sum) has been decoded or FCD has become inactive.
6. In an unsuccessful attempts where the exchange does not send the FSK signal, the CPE should disable FSKE, un-mute the handset and enable the keypad after this interval.



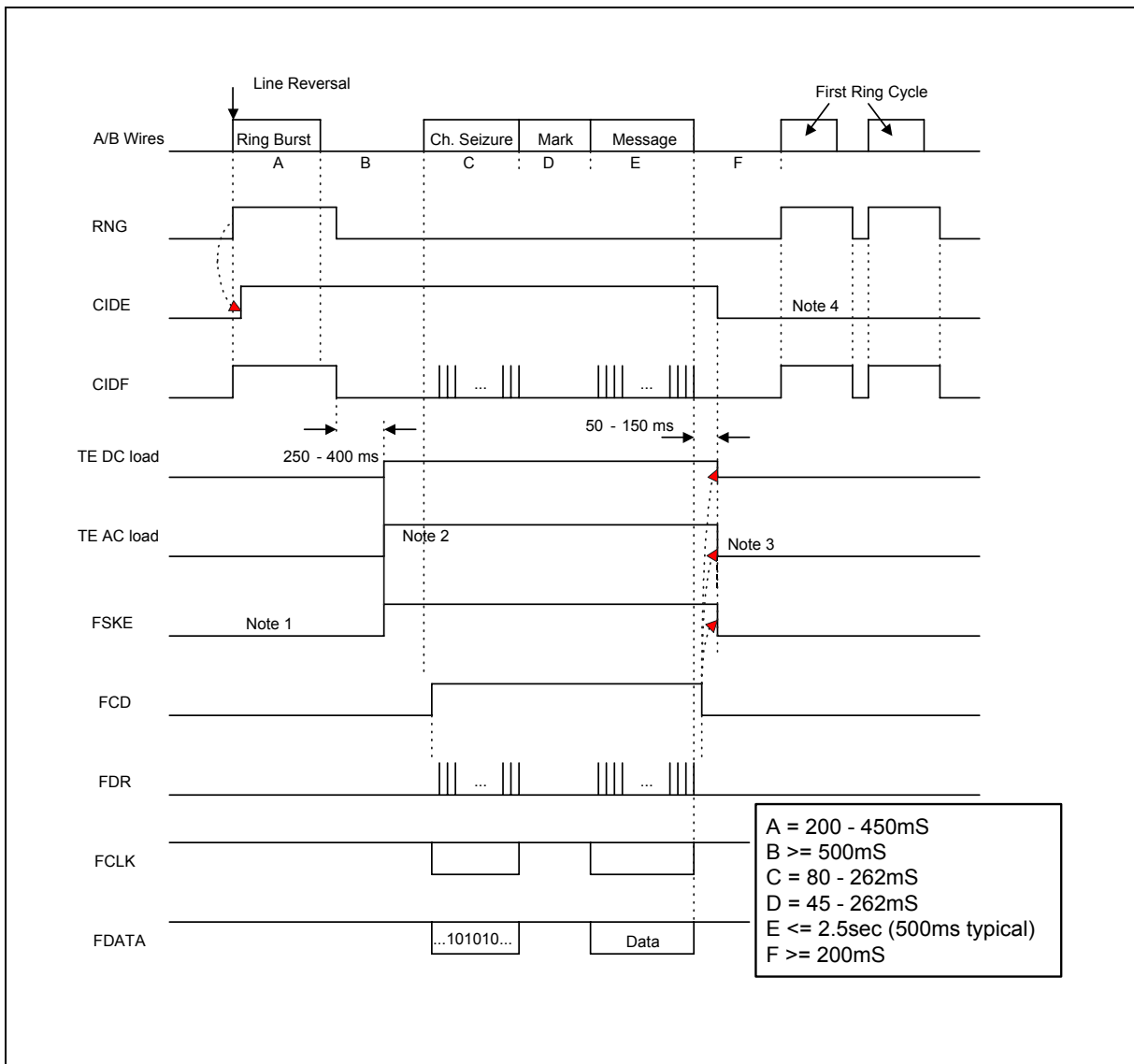

Figure 7-6 Input and Output Timing of CCA Caller Display Service Data Transmission

**Notes:**

1. The CPE designer may choose to set FSKE always high while the CPE is on-hook and the FSK signal is expected.
2. TW/P & E/312 specifies that the AC and DC loads should be applied between 250 - 400 ms after the end of the ring burst.
3. TW/P & E/312 specifies that the AC and DC loads should be removed between 50 - 150 ms after the end of the FSK signal.
4. The CID may not be enable up at the first ring cycle after the FSK data had been processed.



## 8. ELECTRICAL CHARACTERISTICS

### 8.1 Absolute Maximum Ratings\*

(Voltage referenced to  $V_{SS}$  pin)

PARAMETER	SYMBOL	RATING	UNITS
Supply Voltage with respect to $V_{SS}$	$V_{DD}$	-0.3 to 6	V
Voltage on any pin other than supplies (note 1)		-0.7 to $V_{DD} + 0.7$	V
Current at any pin other than supplies		0 to 10	MA
Storage Temperature	$T_{st}$	-65 to 150	°C

**Note:**

\*. Exposure to conditions beyond those listed under Absolute Maximum Ratings may adversely affect the life and reliability of the device.

1.  $V_{DD} + 0.7$  should not exceed maximum rating of supply voltage.

### 8.2 Recommended Operating Conditions

CHARACTERISTICS	SYMBOL	RATING	UNIT
Power Supplies (Analog)	$V_{AD}$	3.0 to 6.0	V
Power Supplies (Digital) EEPROM(E) type(Depend on option) MASK(C) type	$V_{DD}$	2.4 to 3.6 or 3.0 to 5.5 2.2 to 6.0	V
Main Clock Frequency	$f_{OSC}$	3.579545	MHz
Sub Clock Frequency	$f_{SUB}$	32768	Hz
Tolerance on Clock Frequency	$\Delta f_C$	-0.1 to +0.1	%
Operation Temperature	$T_{op}$	0 to 75	°C



### 8.3 DC Characteristics

PARAMETER	SYM.	CONDITION	MIN.	TYP.	MAX.	UNIT	NOTE
Operating Current	$I_{OP1}$	FSK On, dual clock, normal run		2.8		mA	
	$I_{OP2}$	FSK Off, dual clock, normal run		1.3		mA	
	$I_{OP3}$	FSK off, slow run, main osc stopped		50		uA	
	$I_{OP4}$	Idle mode, dual clock		500		uA	
	$I_{OP5}$	Idle mode, main osc stopped		50		uA	
	$I_{OP6}$	Power down mode				1	uA
I/O Ports Input High Voltage	$V_{IH}$		$0.7V_{DD}$		$V_{DD}$	V	
I/O Ports Input Low Voltage	$V_{IL}$		$V_{SS}$		$0.3V_{DD}$	V	
I/O Ports Output High Voltage	$V_{OH}$	$I_{OH} = 2.0 \text{ mA}$	2.4	-	-	V	
I/O Ports Output Low Voltage	$V_{OL}$	$I_{OL} = 2.0 \text{ mA}$	-	-	0.4	V	
BUZ Pin Output High Voltage	$V_{BOH}$	$I_{OH} = 3.5 \text{ mA}$	2.4	-	-	V	
BUZ Pin Output High Voltage	$V_{BOL}$	$I_{OL} = 3.5 \text{ mA}$	0.4	-	-	V	
DTMF Output DC Level	$V_{TDC}$	$R_L = 5K\Omega, V_{DD} = 2.5-3.8$	1.1	-	2.8	V	
DTMF Distortion	DTHD	$R_L = 5K\Omega, V_{DD} = 2.5-3.8$	-	-30	-23	dB	
DTMF Output Voltage	$V_{TO}$	Low group, $R_L = 5K\Omega$	130	150	170	mV rms	
Pre-emphasis		Col/Row	1	2	3	dB	
FSK Output DC Level	$V_{FDC}$	$R_L = 5K\Omega, V_{DD} = 2.5-3.8$	1.1	-	2.8	V	
FSK Distortion	FTHD	$R_L = 5K\Omega, V_{DD} = 2.5-3.8$	-	-	-30	dB	
FSK Output Voltage	VFD	$R_L = 5K\Omega$	75	150	170	mV rms	



DC Characteristics, continued

PARAMETER	SYM.	CONDITION	MIN.	TYP.	MAX.	UNIT	NOTE
Port Pull High Resistor	$R_{PH}$		100	360	1000	$K\Omega$	
Schmitt Input High Threshold	$V_{T+}$	RNGDI, RNGRC	$0.48V_{AD}$	-	$0.68V_{AD}$	V	
Schmitt Input High Threshold	$V_{T-}$	RNGDI, RNGRC	$0.28V_{AD}$	-	$0.48V_{AD}$	V	
Schmitt Hysteresis	$V_{HYS}$	RNGDI, RNGRC		0.2		V	
RNGRC Low Sink Current	$I_{RNGL}$	RNGRC	2.5			mA	
Input Current	$I_{IN}$	INPx, INNx, RNGDI	-	-	1	$\mu A$	
Reference Output voltage	$V_{REF}$	VREF	$0.5V_{AD}$ -4%	-	$0.5V_{AD}$ +4%	V	No load
Reference Output Resistance	$R_{REF}$	VREF	-	-	2	$K\Omega$	

#### 8.4 Electrical Characteristics - Gain Control OP-Amplifier

(Electrical characteristics supersede the recommended operating conditions unless otherwise stated.)

PARAMETER	SYM.	MIN.	TYP $\ddagger$	MAX.	UNITS	TEST CONDITIONS
Input Leakage Current	$I_{IN}$			1	$\mu A$	$V_{SS} \leq V_{IN} \leq V_{DD}$
Input Resistance	$R_{IN}$	10			$M\Omega$	
Input Offset Voltage	$V_{OS}$			25	mV	
Power Supply Rejection Ratio	PSRR	40			dB	1 kHz 0.1 Vpp ripple on $V_{DD}$
Maximum Capacitive Load (GCFBx)	$C_L$			100	pF	
Maximum Resistive Load (GCFBx)	$R_L$	50			$k\Omega$	

**Note:** " $\ddagger$ " Typical figure are at  $V_{DD} = 5V$  and temperature =  $25^\circ C$  are design aids only, not guaranteed and not subject to production testing.



## 8.5 AC Characteristics

(AC timing characteristics supersede the recommended operating conditions unless otherwise stated.)

### Dual Tone Alert Signal Detection Interface

PARAMETER	SYMBOL	MIN.	TYP.	MAX.	UNITS	NOTES
Low Tone Frequency	$f_L$		2130		Hz	
High Tone Frequency	$f_H$		2750		Hz	
Frequency Deviation accept		1.1			%	3
Frequency Deviation reject		3.5			%	4
Maximum Input Signal Level				0.22	dBm <sup>a</sup>	
Input Sensitivity Per Tone		-40	-38		dBm	5
Reject Signal Level Per Tone				-48	dBm	5
Positive and Negative Twist <sup>b</sup> Accept		7			dB	
Noise Tolerance	SNR <sub>TONE</sub>	20			dB	1, 2

#### Notes:

- dBm = decibels with a reference power of 1 mW into 600 ohms, 0 dBm = 0.7746 Vrms.
- Twist =  $20 \log (f_H \text{ amplitude} / f_L \text{ amplitude})$ .
- Both tones have the same amplitude. Both tones are at the nominal frequencies.
- Band limited random noise 300 - 3400 Hz. Present only when tone is present.
- Range within which tones are accepted.
- Ranges outside of which tones are rejected.
- These characteristics are at  $V_{DD} = 5V$  and temperature = 25 °C.

### Dual Tone Alert Signal Detection

PARAMETER	CONDITION	SYM.	MIN.	TYP <sup>‡</sup>	MAX.	UNITS	NOTES
Alert Signal Present Detect Time	ALGR	$t_{DP}$	0.5		10	mS	
Alert Signal Absent Detect Time		$t_{DA}$	0.1		8	mS	

"‡" Typical figure are at  $V_{DD} = 5V$  and temperature = 25 °C are design aids only, not guaranteed and not subject to production testing.



### FSK Detection Interface

PARAMETER	SYMBOL	MIN.	TYP	MAX.	UNITS	NOTES
Input Frequency Detection						
Bell 202 Mark (logic 1)	$f_{\text{Mark}}$	1188	1200	1212		+/- 1 %
Bell 202 Space (logic 0)	$f_{\text{Space}}$	2178	2200	2222	Hz	+/- 1 %
ITU-T V.23 Mark (logic 1)	$f_{\text{Mark}}$	1280.5	1300	1319.5		+/- 1.5 %
ITU-T V.23 Space (logic 0)	$f_{\text{Space}}$	2068.5	2100	2131.5		+/- 1.5 %
Maximum Input Signal Level				-5.78	dBm	
Input Sensitivity		-43			dBm	1, 3
Transmission Rate		1188	1200	1212	baud	
Input Noise Tolerance	$\text{SNR}_{\text{TONE}}$	20			dB	1, 2

#### Notes:

- Both mark and space have the same amplitude. Both mark and space are at the nominal frequencies.
- Band limited random noise 300 - 3400 Hz. Present only when FSK signal is present.
- These characteristics are at  $V_{\text{DD}} = 5\text{V}$  and temperature = 25 °C.

### FSK Detection

PARAMETER	CONDITION	SYM.	MIN.	TYP <sup>‡</sup>	MAX.	UNITS	NOTES
FSK Detection Enable Time	FSKE	$t_{\text{FSK}}$			25	mS	
Input FSK to FCD High Delay	FCD	$t_{\text{CP}}$			25	mS	
Input FSK to FCD Low Delay		$t_{\text{CA}}$	8			mS	
Data Ready ACK Time	FDR	$t_{\text{DR}}$	415	416	417	US	2
Rate	DATA		1188	1200	1212	BpS	1
Input FSK to DATA Delay		$t_{\text{IDD}}$		1	5	mS	
Frequency	DCLK	$f_{\text{DCLK}}$	1201.6	1202.8	1204	Hz	2
High Time		$t_{\text{CH}}$	415	416	417	US	2
Low Time		$t_{\text{CL}}$	415	416	417	US	2
DCLK to FDR Delay	DCLK, FDR	$t_{\text{CRD}}$	415	416	417	US	2

#### Notes:

- FSK input data rate at 1200 +/- 12 baud.
- OSCI frequency at 3.579545 MHz +/- 0.1%.

<sup>‡</sup> Typical figure are at  $V_{\text{DD}} = 5\text{V}$  and temperature = 25 °C are design aids only, not guaranteed and not subject to production testing.



## DTMF Decoder

PARAMETER	SYMBOL	MIN.	TYP.	MAX.	UNITS	NOTES
Input Sensitivity per tone		-29		1	dBm	1, 2
Positive and negative twist accept		7			dB	1, 2
Frequency Deviation accept		1.5			%	1, 2
Frequency Deviation reject		3.5			%	1, 2
3rd Tone Tolerance				-16	dB	1, 2, 3
Noise Tolerance				-12	dB	1, 2, 3
Dial tone Tolerance			22		dB	1, 2, 4

## Notes :

1. signal consists of all DTMF tones.
2. Tone duration is 40 mS at least, tone pause duration is 40 mS at least.
3. Referenced to the lowest level frequency component in DTMF signal.
4. Referenced to the minimum valid accept level.

## DTMF Detection Interface

PARAMETER	CONDITION	SYM.	MIN.	TYP <sup>‡</sup>	MAX.	UNITS	NOTES
DTMF present detect time	Est	$t_{FP}$	0.5		8	mS	
DTMF absent detect time		$t_{FA}$	0.1		8	mS	
DTMF Detected Duration	DTMFD = 1	$t_{DD}$	40			mS	
DTMF Signal Ignore Time	DTMFD = 0	$t_{DI}$			20	mS	
DTMF Pause Accept Time	DTMFD = 1	$t_{DPA}$	20			mS	

"<sup>‡</sup>" Typical figure are at  $V_{DD} = 5V$  and temperature = 25 °C are design aids only, not guaranteed and not subject to production testing.

9. PACKAGE DIMENSION

100L QFP (14 x 20 x 2.75mm footprint 4.8mm)

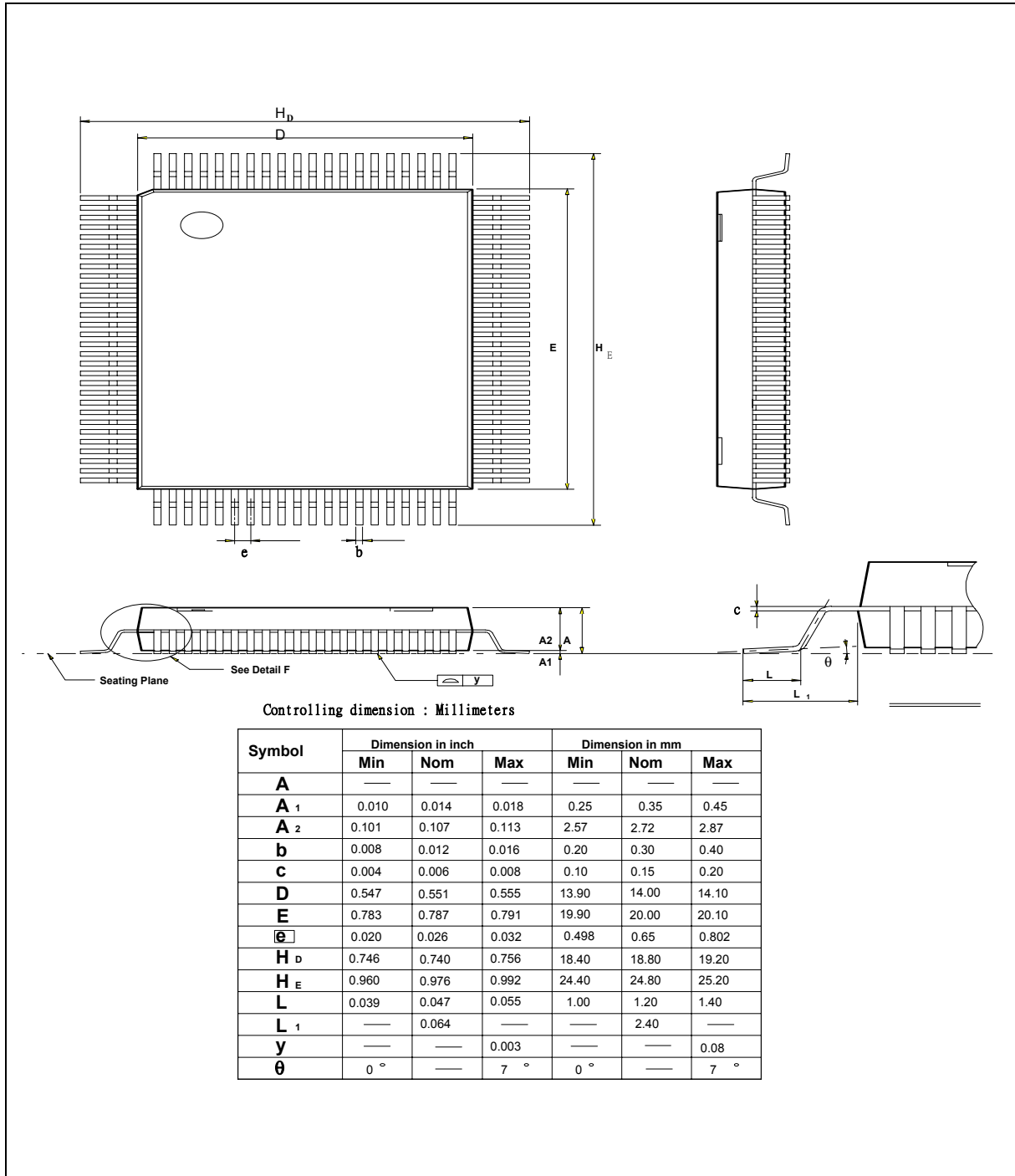





## 10. REVISION HISTORY

REVISION	DATE	MODIFICATION
A6	–	1. Add initial state of registers 2. Modify description of WDCON.0
A7	–	1. Modify the $\mu$ C's operating volt in Features and Operating Conditions. 2. Modify the PMR initial data.
A8	May 16, 2003	1. Add Fsys Low-speed-clock switch as High-speed-clock application note.
A9	Mar 1, 2005	1. Modify MOVX instruction machine cycles data.
A10	July 12, 2005	1. Add lead free package part number. 2. Modify EIF to EXIF.

### Important Notice

Winbond products are not designed, intended, authorized or warranted for use as components in systems or equipment intended for surgical implantation, atomic energy control instruments, airplane or spaceship instruments, transportation instruments, traffic signal instruments, combustion control instruments, or for other applications intended to support or sustain life. Further more, Winbond products are not intended for applications wherein failure of Winbond products could result or lead to a situation wherein personal injury, death or severe property or environmental damage could occur.

Winbond customers using or selling these products for use in such applications do so at their own risk and agree to fully indemnify Winbond for any damages resulting from such improper use or sales.



#### Headquarters

No. 4, Creation Rd. III,  
Science-Based Industrial Park,  
Hsinchu, Taiwan  
TEL: 886-3-5770066  
FAX: 886-3-5665577  
<http://www.winbond.com.tw/>

#### Taipei Office

9F, No.480, Rueiguang Rd.,  
Neihu District, Taipei, 114,  
Taiwan, R.O.C.  
TEL: 886-2-8177-7168  
FAX: 886-2-8751-3579

#### Winbond Electronics Corporation America

2727 North First Street, San Jose,  
CA 95134, U.S.A.  
TEL: 1-408-9436666  
FAX: 1-408-5441798

#### Winbond Electronics Corporation Japan

7F Daini-ueno BLDG, 3-7-18  
Shinyokohama Kohoku-ku,  
Yokohama, 222-0033  
TEL: 81-45-4781881  
FAX: 81-45-4781800

#### Winbond Electronics (Shanghai) Ltd.

27F, 2299 Yan An W. Rd. Shanghai,  
200336 China  
TEL: 86-21-62365999  
FAX: 86-21-62365998

#### Winbond Electronics (H.K.) Ltd.

Unit 9-15, 22F, Millennium City,  
No. 378 Kwun Tong Rd.,  
Kowloon, Hong Kong  
TEL: 852-27513100  
FAX: 852-27552064

*Please note that all data and specifications are subject to change without notice.  
All the trade marks of products and companies mentioned in this data sheet belong to their respective owners.*