

THIS DRAWING IS UNPUBLISHED.

RELEASED FOR PUBLICATION

AUG ,2006.

© COPYRIGHT BY TYCO ELECTRONICS CORPORATION. ALL RIGHTS RESERVED.

LOC DW

DIST

REVISIONS

P	LTR	DESCRIPTION	DATE	DWN	APVD
B		REVISED (ECR-09-002821)	11FEB09	B.W	S.C

NOTES:

- MATERIAL:
 - HOUSING: UL94V-0; COLOR: SEE TABLE.
 - NY9T, THERMOPLASTIC, HIGH TEMP.
 - PBT, THERMOPLASTIC.
 - CONTACTS: PHOSPHOR BRONZE
 - SHELL: SPCC
 - BOARDLOCK: BRASS
 - RIVET: BRASS
- FINISH:
 - CONTACT:
 - GOLD PLATING ON CONTACT AREA,
 - 100u" MIN. MATTE TIN PLATING ON SOLDER TAIL,
 - 50u" MIN. NICKEL UNDERPLATED OVERALL.
 - BOARDLOCK:
 - 100u" MIN. TIN PLATING
 - 50u" MIN. NICKEL UNDERPLATED OVERALL.
 - SHELL: 50u" MIN. NICKEL PLATING OVERALL.
 - RIVET: NICKEL PLATING OVERALL.
- RECOMMENDED PCB THICKNESS: 1.6mm
- WAVE SOLDER CAPABLE TO 265°C PER TE SPEC. 109-202, CONDITION B.

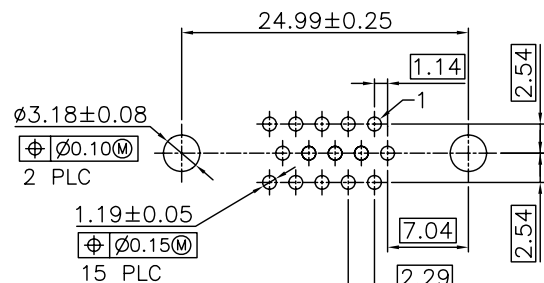
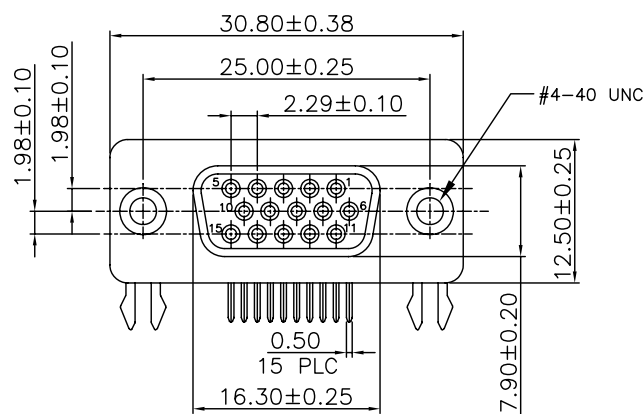

RECOMMENDED P.C. BOARD LAYOUT

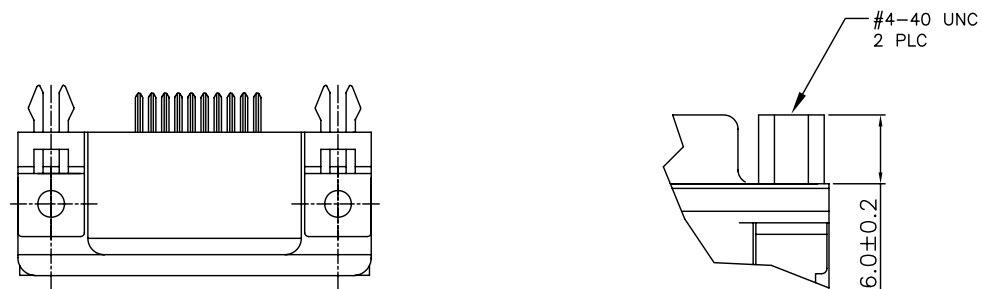
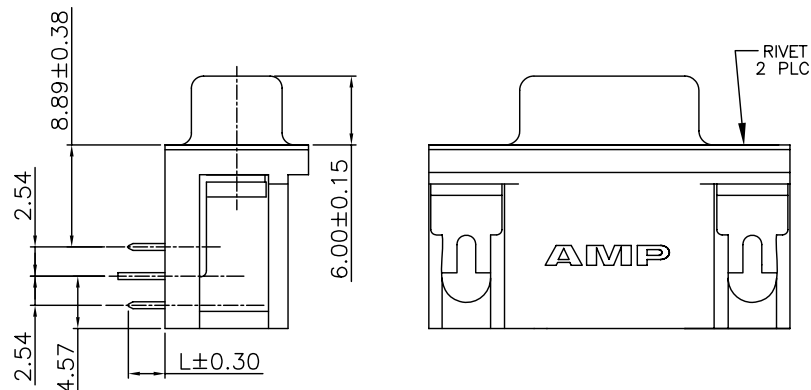
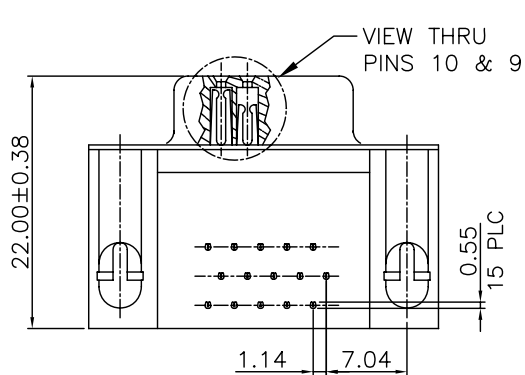

DETAIL Z (W/SCREWLOCKS OPTION)

	△	300U BLUE	3.20	TRAY	10μ"	RIVET, THREADED W/O SCREW	5-1734344-3
OBSOLETE		300U BLUE	3.70	TRAY	30μ"	RIVET, THREADED W/O SCREW	2-1734344-4
		300U BLUE	3.20	TRAY	30μ"	RIVET, THREADED W/O SCREW	2-1734344-3
OBSOLETE		661C BLUE	2.67	TRAY	30μ"	RIVET, THREADED W/O SCREW	2-1734344-2
		661C BLUE	2.67	TRAY	G/F	W/FEMALE SCREWLOCKS (DETAIL Z)	1-1734344-2
		300U BLUE	3.20	TRAY	G/F	W/FEMALE SCREWLOCKS (DETAIL Z)	1-1734344-1
	△	BLACK	2.67	TUBE	15μ"	W/FEMALE SCREWLOCKS (DETAIL Z)	1734344-5
OBSOLETE		300U BLUE	3.20	TUBE	10μ"	RIVET, THREADED W/O SCREW	1734344-4
		300U BLUE	3.20	TRAY	10μ"	RIVET, THREADED W/O SCREW	1734344-3
		661C BLUE	2.67	TRAY	G/F	RIVET, THREADED W/O SCREW	1734344-2
		300U BLUE	3.20	TRAY	G/F	RIVET, THREADED W/O SCREW	1734344-1
	HSG RESIN	PANTONE COLOR	'L'	PACKAGING	GOLD PLATING	FASTENER OPTION	PART NUMBER

THIS DRAWING IS A CONTROLLED DOCUMENT.

DWN J. LEE 16JAN2006
 CHK S. HOU 16JAN2006
 APVD W.J. KE 16JAN2006

Tyco Electronics Tyco Electronics Corporation
 Taipei, Taiwan

NAME RCPT ASM, SZ 1, 15 POSN, RT ANG, FRONT METAL, SHELL AMPLIMITE HD-22

PRODUCT SPEC 108-57541
 QUALIFICATION TEST REPORT 501-57623

WEIGHT 9.0g/PCS(W/ SCREW)
 11.1g/PCS(W/O SCREW)

CUSTOMER DRAWING SCALE 1 of 3 SHEET 1 of 3 REV B

SIZE A3 CAGE CODE 00779 DRAWING NO C=1734344 RESTRICTED TO

THIS DRAWING IS UNPUBLISHED.

RELEASED FOR PUBLICATION

AUG ,2006.

© COPYRIGHT BY TYCO ELECTRONICS CORPORATION. ALL RIGHTS RESERVED.

LOC

DIST

REVISIONS

DW

P

LTR

DESCRIPTION

DATE

DWN

APVD

SEE SHEET 1.

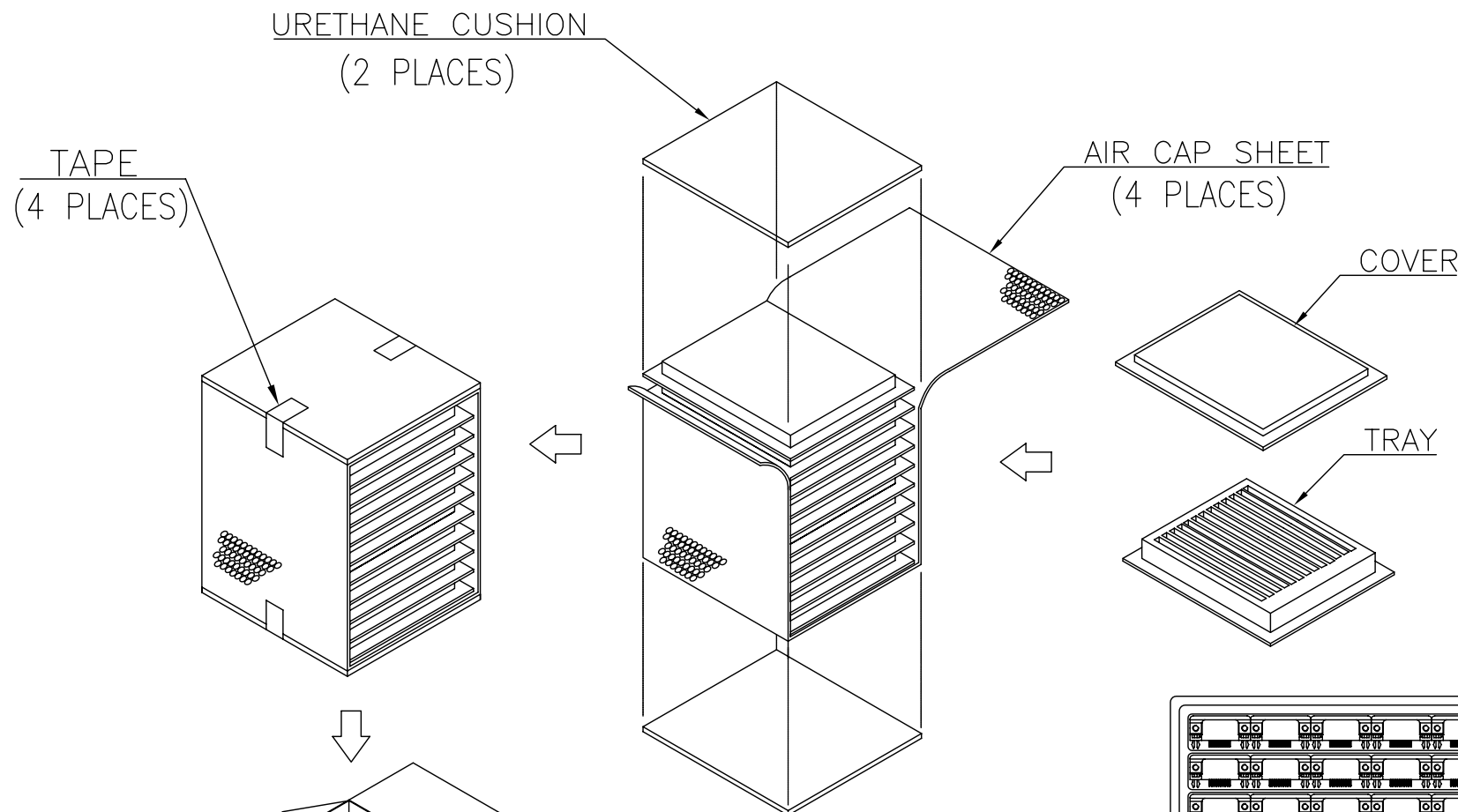

NOTES:

- 1. MATERIAL:
 - 1.1 TRAY: PVC
 - 1.2 SHIPPING CARTON: CORRUGATED FIBERBOARD
- 2. DIMENSION:
 - 2.1 TRAY: L=320, W=230, H=18.9
 - 2.2 SHIPPING CARTON: L=361, W=245, H=272
- 3. QUANTITY:
 - 3.1 PRIMARY PACKING: 100 PCS/TRAY
 - 3.2 SECONDARY PACKING: 10 TRAY/CARTON(1000PCS)
- 4. CARTON WEIGHT:
 - 4.1 W/O SCREWLOCK
 - NET WEIGHT: 8.24 Kg
 - GROSS WEIGHT: 9.24 Kg
 - 4.2 WITH SCREWLOCK
 - NET WEIGHT: 10.24 Kg
 - GROSS WEIGHT: 11.24 Kg

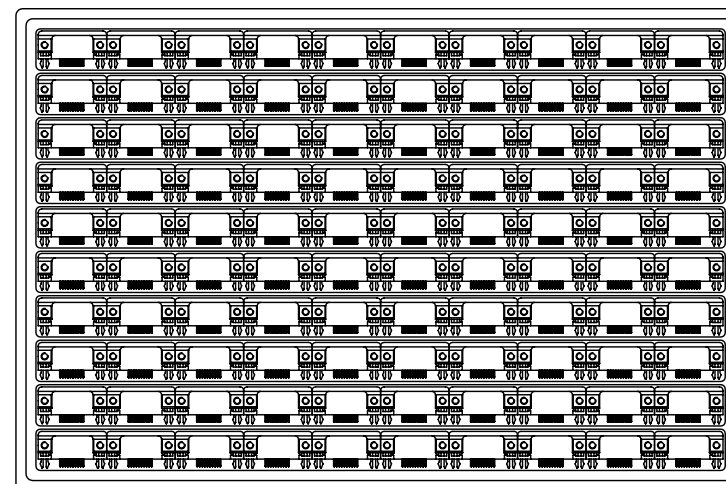
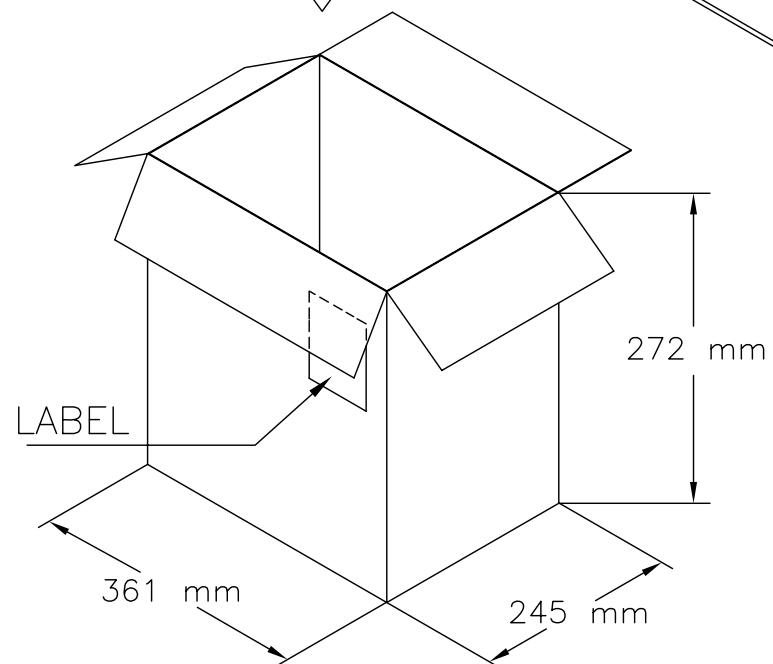

THIS DRAWING IS A CONTROLLED DOCUMENT.		DWN	Tyco Electronics Corporation Taipei, Taiwan	
DIMENSIONS: MM		CHK	NAME	
		APVD	RCPT ASM, SZ 1, 15 POSN, RT ANG, FRONT METAL, SHELL AMPLIMITE HD-22	
TOLERANCES UNLESS OTHERWISE SPECIFIED:		PRODUCT SPEC	SIZE	CAGE CODE
0 PLC ± -	1 PLC ± -	APPLICATION SPEC	A3	00779
2 PLC ± -	3 PLC ± -	WEIGHT	DRAWING NO	
4 PLC ± -	ANGLES ± -	CUSTOMER DRAWING	C=1734344	
MATERIAL	FINISH	SCALE	RESTRICTED TO	REV
				B
		SHEET	2 of 3	

4

3

2

1

THIS DRAWING IS UNPUBLISHED.

RELEASED FOR PUBLICATION

AUG ,2006.

© COPYRIGHT BY TYCO ELECTRONICS CORPORATION. ALL RIGHTS RESERVED.

LOC
DW

DIST

REVISIONS

P	LTR	DESCRIPTION	DATE	DWN	APVD
		SEE SHEET 1.			

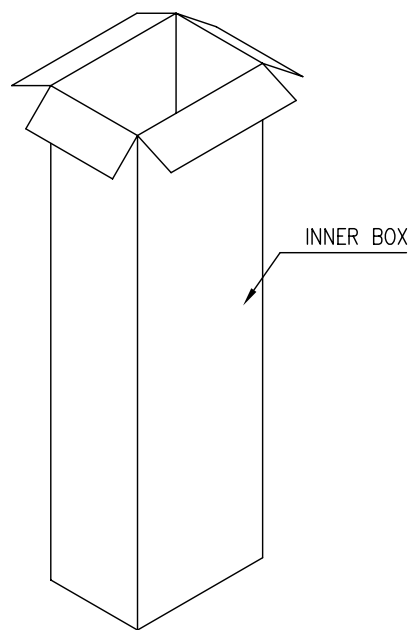
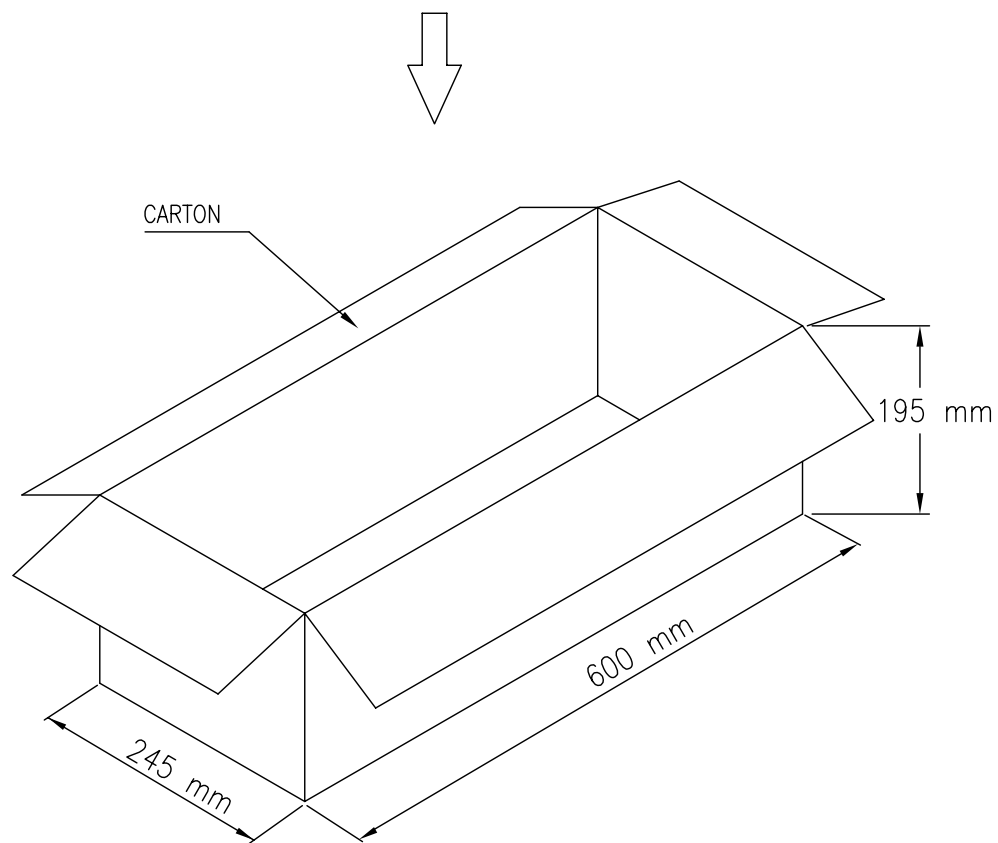
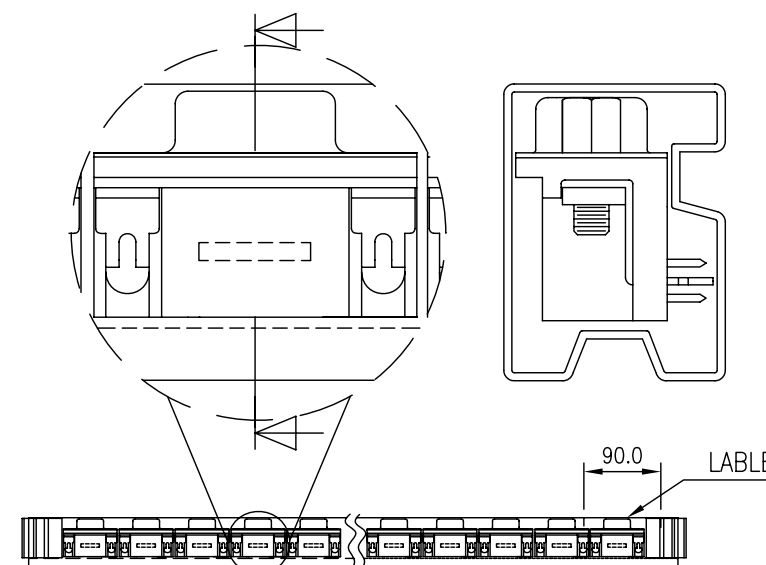
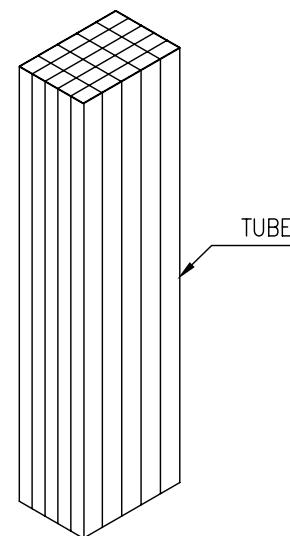
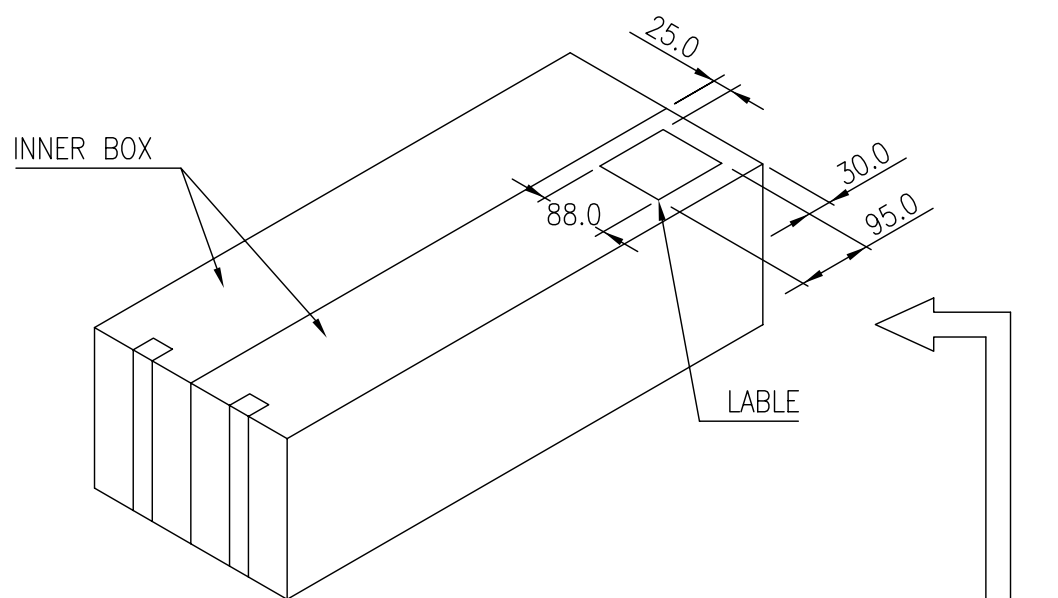

NOTES:

1. MATERIAL:
 - 1.1 TRAY: PVC
 - 1.2 SHIPPING CARTON: CORRUGATED FIBERBOARD
2. DIMENSION:
 - 2.1 TRAY: L=560, W=17.8, H=27.4
 - 2.2 SHIPPING CARTON: L=600, W=245, H=195
3. QUANTITY:
 - 3.1 PRIMARY PACKING: 17 PCS/TURE
 - 3.2 SECONDARY PACKING: 25 TUPE/BOX
 - 3.3 THIRD PACKING: 2 BOX/CARTON(850PCS)
4. CARTON WEIGHT:
 - 4.1 W/O SCREWLOCK
NET WEIGHT: 8.24 Kg
GROSS WEIGHT: 9.24 Kg
 - 4.2 WITH SCREWLOCK
NET WEIGHT: 10 Kg
GROSS WEIGHT: 11 Kg

THIS DRAWING IS A CONTROLLED DOCUMENT.		DWN		Tyco Electronics Corporation Taipei, Taiwan	
DIMENSIONS: MM		CHK		NAME	
TOLERANCES UNLESS OTHERWISE SPECIFIED:		APVD		RCPT ASM, SZ 1, 15 POSN, RT ANG, FRONT METAL, SHELL AMPLIMITE HD-22	
0 PLC ± -		PRODUCT SPEC		SIZE	
1 PLC ± -		APPLICATION SPEC		CAGE CODE	
2 PLC ± -		WEIGHT		DRAWING NO	
3 PLC ± -		CUSTOMER DRAWING		RESTRICTED TO	
4 PLC ± -		SCALE		A3 00779 C=1734344	
ANGLES ± -		SHEET		3 of 3	
MATERIAL		REV		B	
FINISH					