

PLEASE CHECK WWW.MOLEX.COM FOR LATEST PART INFORMATION

Part Number: [0873810819](#)
Status: **Active**
Description: 2.00mm (.079") Pitch Milli-Grid™ Receptacle, Surface Mount, Top Entry, 0.38μm (15μ") Gold (Au) Plating, with Cap, with Locating Pegs, 8 Circuits, Lead-free, Tube

Documents:

[3D Model](#) [Product Specification PS-87380-002 \(PDF\)](#)
[Drawing \(PDF\)](#) [RoHS Certificate of Compliance \(PDF\)](#)

Agency Certification

CSA LR19980
 UL E29179

General

Product Family PCB Receptacles
 Series [87381](#)
 Application Board-to-Board
 Comments With Cap
 Product Literature Order No 987650-1991
 Product Name Milli-Grid™

Physical

Circuits (Loaded) 8
 Circuits (maximum) 8
 Color - Resin Black
 Durability (mating cycles max) 25
 Flammability 94V-0
 Glow-Wire Compliant No
 Lock to Mating Part None
 Material - Metal Phosphor Bronze
 Material - Plating Mating Gold
 Material - Plating Termination Tin-Lead
 Material - Resin High Temperature Thermoplastic
 Number of Rows 2
 Orientation Vertical
 PCB Locator Yes
 PCB Retention None
 Packaging Type Tube
 Pitch - Mating Interface (in) 0.079 In
 Pitch - Mating Interface (mm) 2.00 mm
 Pitch - Term. Interface (in) 0.079 In
 Pitch - Term. Interface (mm) 2.00 mm
 Plating min: Mating (μin) 15
 Plating min: Mating (μm) 0.38
 Plating min: Termination (μin) 50
 Plating min: Termination (μm) 1.27
 Polarized to PCB No
 Robotic Placement Pick and Place Cap
 Surface Mount Compatible (SMC) N/A
 Temperature Range - Operating -55°C to +105°C
 Termination Interface: Style Surface Mount

Electrical

Current - Maximum per Contact 1.9A
 Voltage - Maximum 125V

Solder Process Data

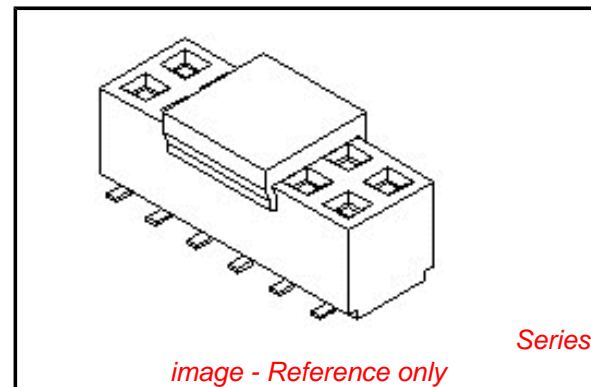

EU RoHS

ELV and RoHS Compliant
REACH SVHC
 Not Reviewed
Halogen-Free Status

China RoHS



Need more information on product environmental compliance?

Email productcompliance@molex.com
 For a multiple part number RoHS Certificate of Compliance, [click here](#)

Please visit the [Contact Us](#) section for any non-product compliance questions.

Search Parts in this Series

[87381Series](#)

Mates With

[87758](#) Vertical, Through Hole, Stackable PCB Header, [87759](#) Vertical, Surface Mount, Stackable PCB Header, [87760](#) Right Angle, Through Hole, Stackable PCB Header, [87831](#) Vertical, Through Hole PCB Header, [87832](#) Vertical, Surface Mount PCB

Duration at Max. Process Temperature (seconds)	12
Lead-free Process Capability	Reflow Capable (SMT only)
Max. Cycles at Max. Process Temperature	1
Process Temperature max. C	260

Material Info

Reference - Drawing Numbers

Product Specification	PS-87380-002
Sales Drawing	SD-87381-***3

This document was generated on 04/09/2010

PLEASE CHECK WWW.MOLEX.COM FOR LATEST PART INFORMATION

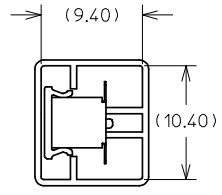
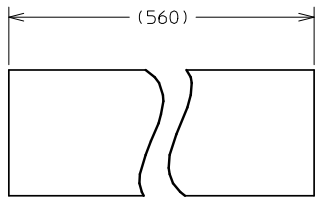
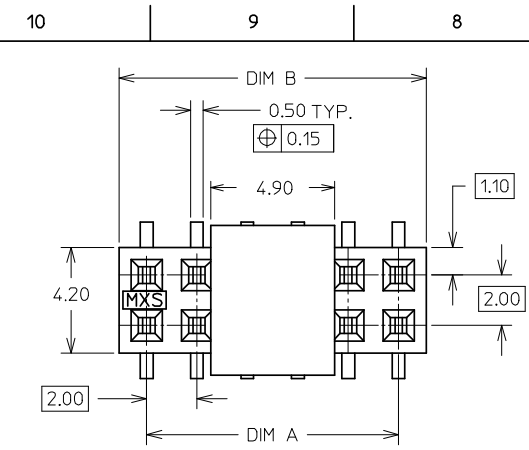

CONNECTOR ORIENTATION IN TUBE

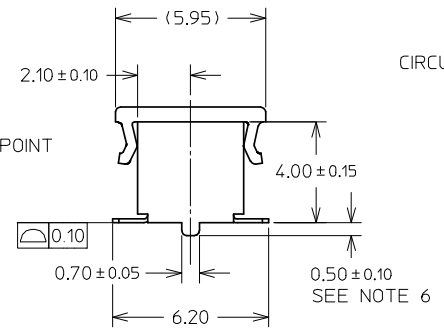
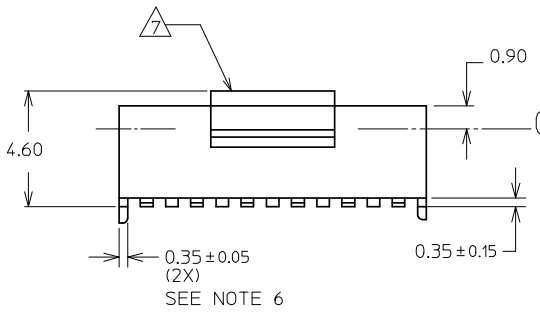

PART NO. LEGEND

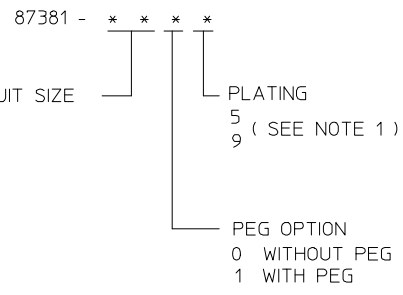

PART NUMBER W/ CAP IN TUBE	CKT. SIZE	DIM A	DIM B
87381-04**	4	2.00	4.00
87381-06**	6	4.00	6.00
87381-08**	8	6.00	8.00
87381-10**	10	8.00	10.00
87381-12**	12	10.00	12.00
87381-141*	14	12.00	14.00
87381-16**	16	14.00	16.00
87381-18**	18	16.00	18.00
87381-20**	20	18.00	20.00
87381-22**	22	20.00	22.00
87381-24**	24	22.00	24.00
87381-26**	26	24.00	26.00
87381-28**	28	26.00	28.00
87381-30**	30	28.00	30.00
87381-32**	32	30.00	32.00
87381-34**	34	32.00	34.00
87381-36**	36	34.00	36.00
87381-38**	38	36.00	38.00
87381-40**	40	38.00	40.00
87381-42**	42	40.00	42.00
87381-44**	44	42.00	44.00
87381-46**	46	44.00	46.00
87381-48**	48	46.00	48.00
87381-50**	50	48.00	50.00

- NOTES:
- PLATING FINISH :
 - 5 - 0.76µm MIN. GOLD IN CONTACT AREA
1.27µm MIN TIN IN SOLDER TAIL AREA
BOTH OVER 1.27µm MIN NICKEL OVERALL
 - 9 - 0.38µm MIN GOLD IN CONTACT AREA
1.27µm MIN TIN IN SOLDER TAIL AREA
BOTH OVER 1.27µm MIN NI OVERALL
 - MATERIAL:
 - HOUSING : NYLON 4/6, 94V-0, COLOUR BLACK
 - CAP : PCT, GLASS FILLED, COLOUR BLACK
 - TERMINAL : COPPER ALLOY
 - EMBOSS TAPE : CLEAR POLYSTYRENE
 - COVER TAPE : CLEAR POLYESTER
 - PRODUCT SPECIFICATION PS-87380 APPLIES
 - COPLANARITY OF SOLDER TAILS ARE TO BE MEASURED BY RESTING THE PART ON A FLAT GAUGE SURFACE
 - OTHER PLATING OPTIONS AVAILABLE. PLEASE CONTACT FACTORY
 - PEG AND PCB HOLE OPTIONAL. SEE PART LEGEND FOR PART CONFIGURATON
 - POSITION OF CAP TO BE LOCATED AT CENTER OF DIM A REGARDLESS OF CKT SIZES.
 - 12 CKT SIZE SHOWN FOR ILLUSTRATION ONLY. SEE CHART FOR ALL AVAILABLE PART SIZES. 22 CKT ILLUSTRATED FOR TAPE/REEL VERSION ON SHT 2.
 - PACKING QTY PER REEL IS APPROX. 800PCS.
 - PARTS SHALL BE PACKED IN MOISTURE BARRIER BAG.

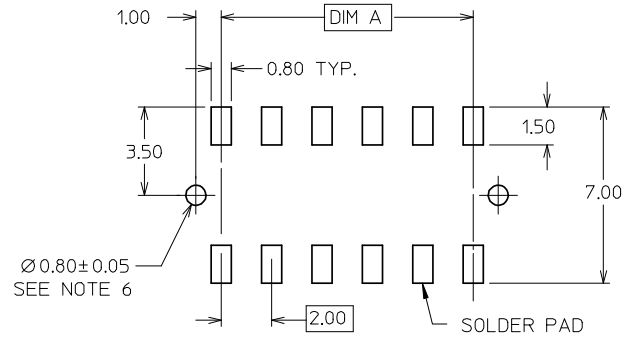

RECOMMENDED PCB LAYOUT

PDR#S-001789-00-00 EC NO: S2008-0938 DRWN:SKANG CHKD:ATSEE APPR:MLONG	2008/04/16 2008/04/16 2008/04/16	DESCRIPTION D3	QUALITY SYMBOLS	GENERAL TOLERANCES (UNLESS SPECIFIED)	DIMENSION STYLE	SCALE	DESIGN UNITS	THIRD ANGLE PROJECTION															
			$\nabla=0$ $\square=0$	<table border="1"> <thead> <tr> <th></th> <th>mm</th> <th>INCH</th> </tr> </thead> <tbody> <tr> <td>4 PLACES</td> <td>± ---</td> <td>± ---</td> </tr> <tr> <td>3 PLACES</td> <td>± ---</td> <td>± ---</td> </tr> <tr> <td>2 PLACES</td> <td>± 0.2</td> <td>± ---</td> </tr> <tr> <td>1 PLACE</td> <td>± ---</td> <td>± ---</td> </tr> </tbody> </table>		mm	INCH	4 PLACES	± ---	± ---	3 PLACES	± ---	± ---	2 PLACES	± 0.2	± ---	1 PLACE	± ---	± ---	MM ONLY	NTS	METRIC	
				mm	INCH																		
			4 PLACES	± ---	± ---																		
3 PLACES	± ---	± ---																					
2 PLACES	± 0.2	± ---																					
1 PLACE	± ---	± ---																					
	<table border="1"> <thead> <tr> <th></th> <th>DATE</th> <th>TITLE</th> </tr> </thead> <tbody> <tr> <td>DRAWN BY</td> <td>1999/01/06</td> <td>KSEE</td> </tr> <tr> <td>CHECKED BY</td> <td>1999/01/11</td> <td>KCL ING</td> </tr> <tr> <td>APPROVED BY</td> <td>1999/01/11</td> <td>SKTOH</td> </tr> </tbody> </table>		DATE	TITLE	DRAWN BY	1999/01/06	KSEE	CHECKED BY	1999/01/11	KCL ING	APPROVED BY	1999/01/11	SKTOH	MGRID, TOP ENTRY RECEPT. 4MM HT., W/PEGS/CAP IN TUBE AND T&R, SMT									
	DATE	TITLE																					
DRAWN BY	1999/01/06	KSEE																					
CHECKED BY	1999/01/11	KCL ING																					
APPROVED BY	1999/01/11	SKTOH																					
	MATERIAL NO. SEE TABLE	DOCUMENT NO. SD-87381-***3	MOLEX INCORPORATED		SHEET NO. 1 OF 2																		

DRAFT WHERE APPLICABLE MUST REMAIN WITHIN DIMENSIONS

THIS DRAWING CONTAINS INFORMATION THAT IS PROPRIETARY TO MOLEX INCORPORATED AND SHOULD NOT BE USED WITHOUT WRITTEN PERMISSION

10 9 8 7 6 5 4 3 2 1

CKT SIZE	PLATING FINISH (SEE NOTE #1)	PART NO WITH CAP IN TAPE / REEL	PART NO WITH CAP IN TUBE	W	So	Ao	F	Bo	Ko
08	9	87381-9016	87381-0819	24.00	-	7.00	11.50	8.50	4.80
10	5	87381-9030	87381-1015	24.00	-	7.00	11.50	10.50	4.80
30	9	87381-9015	87381-3019	56.00	52.40	7.00	26.20	30.50	4.80
50	9	87381-9027	87381-5019	72.00	68.40	7.00	34.20	50.50	4.80
50	5	87381-9028	87381-5015	72.00	68.40	7.00	34.20	50.50	4.80

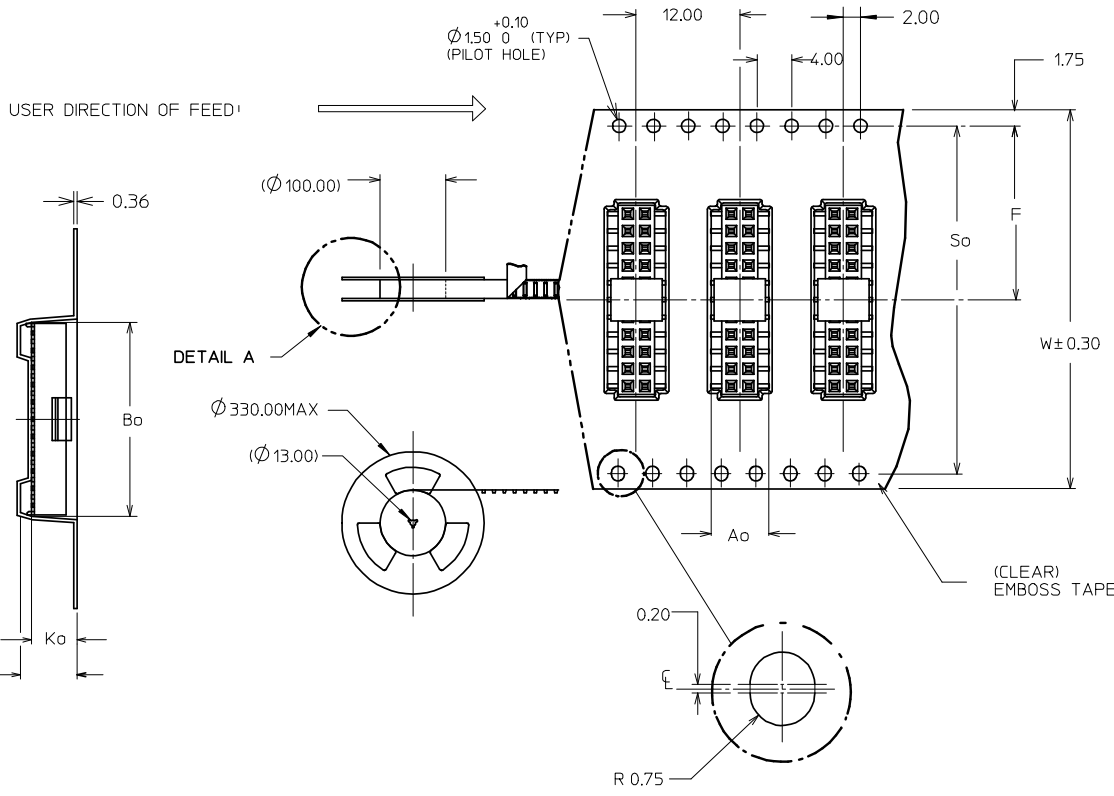

NOTES:

1. LEADER AND TRAILER TAPE

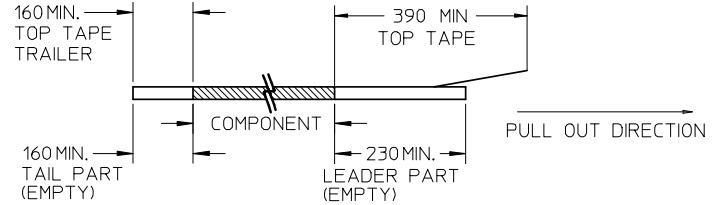

2. PEELING OFF FORCE OF THE TOP TAPE: 20-80gf.
(PEELING DIRECTION AS SHOWN IN FOLLOWING FIGURE)

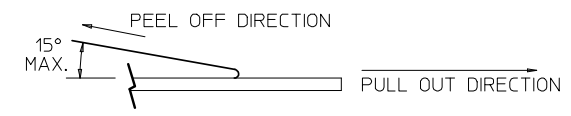

3. PACKAGING STANDARD IS AS PER EIA-481.

4. TAPE & REEL QUANTITY = 800 PCS/REEL

TAPE & REEL ORIENTATION (22 CKT SHOWN FOR REF)
(NTS)

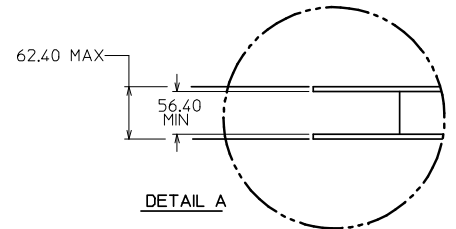

PDR#S-001789-00-00	DESCRIPTION
EC NO: S2008-0938	2008/04/16
DRWN:SKANG	2008/04/16
CHKD:ATSEE	2008/04/16
APPR:MLONG	2008/04/16
D3	REV

QUALITY SYMBOLS	GENERAL TOLERANCES (UNLESS SPECIFIED)	
	mm	INCH
▽=0	4 PLACES ± ---	± ---
∇=0	3 PLACES ± ---	± ---
	2 PLACES ± 0.2	± ---
	1 PLACE ± ---	± ---
	ANGULAR ± 3 °	
	DRAFT WHERE APPLICABLE MUST REMAIN WITHIN DIMENSIONS	

DIMENSION STYLE		SCALE	DESIGN UNITS
MM ONLY		NTS	METRIC
DRAWN BY	DATE	TITLE	
KSEE	1999/01/06	MGRID, TOP ENTRY RECEPT.	
CHECKED BY	DATE	4MM HT., W/PEGS/CAP	
KCL ING	1999/01/11	IN TUBE AND T&R, SMT	
APPROVED BY	DATE	MOLEX INCORPORATED	
SKTOH	1999/01/11	MOLEX INCORPORATED	
MATERIAL NO.	DOCUMENT NO.	SHEET NO.	
SEE TABLE	SD-87381-***3	2 OF 2	

THIRD ANGLE PROJECTION
MOLEX INCORPORATED
SD-87381-***3
2 OF 2

9 8 7 6 5 4 3 2 1